

Board of Education Regular Meeting
Monday, December 14, 2020 7:00 PM
Shelby-Rising City School Room 402
650 N. Walnut
Shelby, NE 68662-0218

1. Call to Order
2. Pledge of Allegiance
3. Announce Open Meeting Act Posting and Location
4. Recitation of the Mission Statement: The mission of the Shelby-Rising City Public School is to provide a quality education through Innovation, Integrity, Accountability and Service
5. Recognition of Visitors
During this time visitors may request to the board the opportunity to speak at the appropriate time. The Board then allow for Public Comments. Each speaker will be limited to 5 minutes and all of the Public Comment time will be limited to 30 minutes. An exception will be made for those speakers appearing on the Agenda as presenters.
 1. Student Presentation: Mrs. Jakub and the S-RC Dance Team participants will present information to the Board.
6. Approval of Agenda
7. Consent Agenda
 1. Minutes
 2. Treasurers Report
8. District Reports
 1. Mrs. Willis will be presenting the Board with an update of the External Visitation that will be conducted virtually next month.
 2. Technology Report
 3. Maintenance/Facilities/Transportation Report
 4. Board/Committee Report

1. Negotiations Committee Report
9. Administrative Reports
 1. Athletic Director/Activities Director Report
 2. Elementary Principals Report
 3. Secondary Principals Report
 4. Superintendents Report
10. Discussion Items
11. Action Items
 1. The Board will discuss, consider and take all necessary action on the purchase of a Hobart Model AM15T-2 Dishwasher with two 6 Pan Racks and the removal of the current machine. Total cost is \$16,800. The work will be completed on or before January 18.
 2. The Board will present, discuss, consider and take all necessary action on the Annual Superintendent Evaluation.
 3. The Board will discuss, consider and take all necessary action on setting the rate for sub pay during the use of a certificated staff member's planning period per Board policy. The rate for the 2020-21 school year will be set at \$15.00 per covered period to be paid at the end of each semester.
12. Set Dates
13. Adjournment

Board of Education Regular Meeting
Monday, November 16, 2020 7:00 PM Central

Shelby-Rising City School Room 402
650 N. Walnut
Shelby, NE 68662-0218

Kasey Hopwood: Present
Jeff Kuhnel: Present
Geoffrey Ruth: Present
Jackie Sliva: Present
Heath Vrbka: Present
Chris Whitmore: Present
Present: 6.

1. Call to Order

2. Pledge of Allegiance

3. Announce Open Meeting Act Posting and Location

4. Recitation of District Mission Statement: The mission of the Shelby/Rising City Public Schools is to provide a quality education through Innovation, Integrity, Accountability and Service.

5. Recognition of Visitors

5.1. Mrs. Segner and FFA members will present an update on fall FFA activities.

6. Approval of Agenda

Motion to approve agenda as presented Passed with a motion by Kasey Hopwood and a second by Jackie Sliva.

Kasey Hopwood: Yea, Jeff Kuhnel: Yea, Geoffrey Ruth: Yea, Jackie Sliva: Yea, Heath Vrbka: Yea, Chris Whitmore: Yea
Yea: 6, Nay: 0

7. Consent Agenda

Motion to approve Consent Agenda Passed with a motion by Chris Whitmore and a second by Heath Vrbka.

Kasey Hopwood: Yea, Jeff Kuhnel: Yea, Geoffrey Ruth: Yea, Jackie Sliva: Yea, Heath Vrbka: Yea, Chris Whitmore: Yea
Yea: 6, Nay: 0

7.1. Minutes

7.2. Treasurers Report

8. Administrative Reports

8.1. Athletic Director/Activities Director Report

8.2. Elementary Principals Report

8.3. Secondary Principals Report

8.4. Superintendents Report

9. District Reports

9.1. Technology Report

9.2. Maintenance/Facilities/Transportation Report

9.3. Board/Committee Report

10. Discussion Items

10.1. Discuss the evaluation of the superintendent

11. Action Items

11.1. Discuss, consider and take all necessary action on the annual audit and AFR.

Motion to accept and approve the annual audit and AFR. Passed with a motion by Heath Vrbka and a second by Kasey Hopwood.

Kasey Hopwood: Yea, Jeff Kuhnel: Yea, Geoffrey Ruth: Yea, Jackie Sliva: Yea, Heath Vrbka: Yea, Chris Whitmore: Yea

Yea: 6, Nay: 0

11.2. Discuss, consider and take all necessary action on policy revisions (second reading)

Motion to approve the second reading of the policy revisions: 0402.15, 0404.02, 0404.13, 0503.04. Passed with a motion by Chris Whitmore and a second by Geoffrey Ruth.

Kasey Hopwood: Yea, Jeff Kuhnel: Yea, Geoffrey Ruth: Yea, Jackie Sliva: Yea, Heath Vrbka: Yea, Chris Whitmore: Yea

Yea: 6, Nay: 0

11.3. Discuss, consider and take all necessary action on the revision of the Senior Service Project.

Motion to approve the revision of the Senior Service Project to allow Mr. Bobolz the leniency to choose or forego the Senior Service Project if unable to complete due to Covid restrictions. Passed with a motion by Jackie Sliva and a second by Chris Whitmore.

Kasey Hopwood: Yea, Jeff Kuhnel: Yea, Geoffrey Ruth: Yea, Jackie Sliva: Yea, Heath Vrbka: Yea, Chris Whitmore: Yea

Yea: 6, Nay: 0

11.4. Discuss, consider and take all necessary action on the updated Return to School plan.

Motion to approve the updated Return to School Plan. Board elects to have no school on the 2nd and 16th of December to allow for more teacher planning time. Passed with a motion by Chris Whitmore and a second by Heath Vrbka.

Kasey Hopwood: Yea, Jeff Kuhnel: Yea, Geoffrey Ruth: Yea, Jackie Sliva: Yea, Heath Vrbka: Yea, Chris Whitmore: Yea

Yea: 6, Nay: 0

12. Set Dates

13. Executive Session

14. Adjournment

Motion to adjourn at 8:32pm. Passed with a motion by Jeff Kuhnel and a second by Kasey Hopwood.

Kasey Hopwood: Yea, Jeff Kuhnel: Yea, Geoffrey Ruth: Yea, Jackie Sliva: Yea, Heath Vrbka: Yea, Chris Whitmore: Yea

Yea: 6, Nay: 0

Board of Education Special Meeting
Monday, November 30, 2020 6:00 PM Central

Shelby-Rising City School Library
650 N. Walnut
Shelby, NE 68662-0218

Kasey Hopwood: Present
Jeff Kuhnel: Present
Geoffrey Ruth: Present
Jackie Sliva: Present
Heath Vrbka: Present
Chris Whitmore: Present

Present: 6.

Meeting called to order by Jeff Kuhnel at 6pm.

1. Call to Order

Motion to enter into executive session to protect the reputation of potential Superintendent candidates. Passed with a motion by Geoffrey Ruth and a second by Chris Whitmore.

Kasey Hopwood: Yea, Jeff Kuhnel: Yea, Geoffrey Ruth: Yea, Jackie Sliva: Yea, Heath Vrbka: Yea, Chris Whitmore: Yea

Yea: 6, Nay: 0

Closed session ended at 7:29pm.

2. Pledge of Allegiance

3. Recitation of the District Mission Statement: The mission of the Shelby Rising City Public Schools is to provide a quality education through Innovation, Integrity, Accountability and Service

4. Announce Open Meeting Act Posting and Location

5. Recognition of Visitors

6. Approval of Agenda

7. Discussion Items

7.1. Meet with NASB representatives and select the finalists for Superintendent of Schools

8. Set Dates

9. Adjournment

Motion to adjourn at 8:22pm. Passed with a motion by Jeff Kuhnel and a second by Kasey Hopwood.

Kasey Hopwood: Yea, Jeff Kuhnel: Yea, Geoffrey Ruth: Yea, Jackie Sliva: Yea, Heath Vrbka: Yea, Chris Whitmore: Yea

Yea: 6, Nay: 0

Board of Education Special Meeting
Monday, December 7, 2020 12:00 PM Central

Shelby-Rising City School Room 402
650 N. Walnut
Shelby, NE 68662-0218

Kasey Hopwood: Present
Jeff Kuhnel: Present
Geoffrey Ruth: Present
Jackie Sliva: Present
Heath Vrbka: Present
Chris Whitmore: Present

Present: 6.

Meeting was called to order at 11:55am

1. Call to Order

2. Pledge of Allegiance

3. Announce Open Meeting Act Posting and Location

4. Recognition of Visitors

5. Approval of Agenda

6. Interview candidates for Superintendent of Schools. Interview #1 at Noon and Interview #2 at 1:30 PM

7. Adjournment

Motion to adjourn at 3:15pm Passed with a motion by Jeff Kuhnel and a second by Kasey Hopwood.

Kasey Hopwood: Yea, Jeff Kuhnel: Yea, Geoffrey Ruth: Yea, Jackie Sliva: Yea, Heath Vrbka: Yea, Chris Whitmore: Yea

Yea: 6, Nay: 0

Board of Education Special Meeting
Tuesday, December 8, 2020 12:00 PM Central

Shelby-Rising City School Library
650 N. Walnut
Shelby, NE 68662-0218

Kasey Hopwood: Present
Jeff Kuhnel: Present
Geoffrey Ruth: Present
Jackie Sliva: Present
Heath Vrbka: Present
Chris Whitmore: Present

Present: 6.

Meeting called order.

1. Call to Order

2. Pledge of Allegiance

3. Announce Open Meeting Act Posting and Location

4. Recognition of Visitors

5. Approval of Agenda

6. Interview candidates for Superintendent of Schools. Candidate #3 at Noon and Candidate #4 at 1:30 PM

7. Adjournment

Motion to adjourn at 3:22pm. Passed with a motion by Jeff Kuhnel and a second by Kasey Hopwood.

Kasey Hopwood: Yea, Jeff Kuhnel: Yea, Geoffrey Ruth: Yea, Jackie Sliva: Yea, Heath Vrbka: Yea, Chris Whitmore: Yea

Yea: 6, Nay: 0

Board of Education Special Meeting
Tuesday, December 8, 2020 7:00 PM Central

Shelby-Rising City School Room 402
650 N. Walnut
Shelby, NE 68662-0218

Kasey Hopwood: Present
Jeff Kuhnel: Present
Geoffrey Ruth: Present
Jackie Sliva: Present
Heath Vrbka: Present
Chris Whitmore: Present

Present: 6.

Meeting called to order at 7:01pm.

1. Call to Order

Left executive session at 8:56pm.

2. Pledge of Allegiance

Motion to allow the Board President or Vice President of the Board negotiating rights for the hiring of the new Superintendent. Passed with a motion by Kasey Hopwood and a second by Heath Vrbka.

Kasey Hopwood: Yea, Jeff Kuhnel: Yea, Geoffrey Ruth: Yea, Jackie Sliva: Yea, Heath Vrbka: Yea, Chris Whitmore: Yea

Yea: 6, Nay: 0

3. Announce Open Meeting Act Posting and Location

4. Recognition of Visitors

5. Approval of Agenda

6. Discussion Items

6.1. Discuss the results of interviews for Superintendent of Schools

7. Action Items

Motion was made by Jeff Kuhnel at 8:24pm to enter into executive session to finalize details of negotiations related to salary, benefit package, and contract language.

7.1. Discuss, consider and take all necessary action on the offering of the contract for Superintendent of Schools for the 2021-22 school year

8. Adjournment

Motion to adjourn at 9:25pm. Passed with a motion by Heath Vrbka and a second by Jeff Kuhnel.

Kasey Hopwood: Yea, Jeff Kuhnel: Yea, Geoffrey Ruth: Yea, Jackie Sliva: Yea, Heath Vrbka: Yea, Chris Whitmore: Yea

Yea: 6, Nay: 0

Board of Education
Shelby-Rising City Public Schools
Regular Meeting

December 14, 2020

7:00 PM

<u>Check #</u>	<u>Vendor Name</u>	<u>Amount</u>
Checking	1	Fund: 01 GENERAL FUND
38793	ALL STAR AUTO GLASS	511.97
38794	AMAZON	1,076.50
38795	BLACK HILLS ENERGY	745.51
38796	BUTLER COUNTY CLINIC	150.00
38797	CAPITAL ONE	32.09
38798	CENTRAL NEBRASKA REHABILITATION SERVICES	3,953.49
38799	CONNECTING POINT COMPUTER CENT	89.99
38800	CONSTELLATION ENERGY	308.82
38801	CROSS ROADS CONFERENCE	250.00
38802	CUBBYS CORPORATE OFFICE	1,430.07
38803	CULLIGAN OF YORK	98.50
38804	CYZA, MARK	14.86
38805	DAVID CITY PUBLIC SCHOOL	6,963.15
38806	DIETZE MUSIC HOUSE	36.51
38807	E.S.U. #7	571.03
38808	EAKES OFFICE SOLUTIONS	1,088.99
38809	EDUCATIONAL SERVICE UNIT #7	766.22
38810	EDUCATIONAL SERVICE UNIT #7	50,861.13
38811	EGAN SUPPLY CO.	773.04
38812	FIRST BOOK	151.69
38813	FLINN SCIENTIFIC INC.	2,800.00
38814	GENERAL FUND-PETTY CASH	46.00
38815	HOMETOWN LEASING	431.27
38816	JACKSON SERVICES, INC	395.50
38817	JJ & ZAK	400.00
38818	JOSTENS	358.28

<u>Check #</u>	<u>Vendor Name</u>	<u>Amount</u>
38819	KSB SCHOOL LAW, PC, LLO	1,764.00
38820	LINGO	264.70
38821	M & O DOOR PRODUCTS	3,470.65
38822	MATHESON TRI-GAS INC.	897.90
38823	MENARDS	47.92
38824	MID-AMERICAN RESEARCH CHEMICAL	114.00
38825	MIDWEST ALARM SERVICES	122.37
38826	NAPA AUTO AND TRUCK PARTS	89.90
38827	NE SAFETY CENTER	2,025.00
38828	OCCUPATIONAL HEALTH SERVICES	223.00
38829	ONE SOURCE	5.00
38830	ORKIN PEST CONTROL	91.17
38831	PAY FLEX	100.00
38832	PEKNY & ASSOCIATES	8,150.00
38833	PINNACLE BANK	833.66
38834	PITNEY BOWES	210.96
38835	POLK CO. RURAL PUBLIC POWER DISTRICT	12,929.61
38836	POLK COUNTY NEWS	114.84
38837	RC PIT STOP	91.31
38838	SAVVAS LEARNING COMPANY LLC	3,707.30
38839	SCHOOL SPECIALITY	200.98
38840	SHELBY AUTO CLINIC	950.86
38841	SHELBY LUMBER CO.	28.53
38842	STROMSBURG WATER & CONDITIONING INC.	50.00
38843	TIRE OUTLET, INC.	25.00
38844	TRUCK CENTER COMPANIES	88.19
38845	VERIZON WIRELESS	298.75

<u>Check #</u>	<u>Vendor Name</u>	<u>Amount</u>
38846	VERSATILE SUPPORT SERVICES, INC.	206.25
38847	VILLAGE OF SHELBY	1,128.70
38848	VIVACITY TECH PBC	950.00
38849	WINDSTREAM	632.04

INVOICE TOTAL:	\$ 114,117.20
PAYROLL TOTAL:	\$ 409,700.82
TOTAL:	\$ 523,818.02

Invoice Listing - Detail
DECEMBER 2020 GENERAL FUND INVOICES

Batch Description: DECEMBER 2020 GENERAL FUND INVOICES
Vendor ID: ALLSTAR ALL STAR AUTO GLASS

Processing Month: 12/2020
Invoice Number: WAS1030733
Invoice Date: 12/10/2020
Due Date: 12/14/2020
Status: A
1099 Amount: 0.00

End of Fiscal Year Expense Invoices:
Amount: 511.97

Description: 1
Sequence: 1
Check Type:
Chart of Account Number
01 2730 431 000 0000 0 000
WINDSHIELD

Checking Account ID:

Check Number:

Check Date:

Detail Description
WINDSHIELD
Detail Amount 511.97
Asset/Asset Tag N

Vendor ID: AMAZON

AMAZON

Description: 1
Sequence: 1
Check Type:
Chart of Account Number
01 1100 610 001 0100 0 000
TUESDAYS WITH MORRIE
01 2220 640 000 0000 0 000
LIBRARY BOOKS
01 2590 610 000 0000 0 000
LRG ENVELOPES & PRESS BOARD
FOLDERS
01 2610 610 000 2020 0 000
FACE MASKS
01 1190 610 002 0000 0 000
PENCIL CASES
01 1100 610 002 0070 0 000
STORAGE BENS
01 1100 610 002 0040 0 000
SHEET PROTECTORS & PERMANENT
MARKERS

Checking Account ID:

Check Number:

Check Date:

Detail Description
TUESDAYS WITH MORRIE
LIBRARY BOOKS
LRG ENVELOPES & PRESS BOARD
FACE MASKS
PENCIL CASES
STORAGE BENS
SHEET PROTECTORS & PERMANENT
MARKERS
Detail Amount 343.60
Asset/Asset Tag N
236.32 N
133.64 N
219.94 N
40.04 N
79.00 N
23.96 N

Invoice Number: 121020
Amount: 1,076.50

Invoice Date: 12/10/2020
Due Date: 12/14/2020
Status: A
1099 Amount: 0.00

Vendor ID: BLACKHILLS

BLACK HILLS ENERGY

Description: 1
Sequence: 1
Check Type:
Chart of Account Number
01 2610 621 000 0000 0 000
FUEL

Checking Account ID:

Check Number:

Check Date:

Detail Description
FUEL
Detail Amount 745.51
Asset/Asset Tag N

Invoice Number: 121020
Amount: 745.51

Invoice Date: 12/10/2020
Due Date: 12/14/2020
Status: A
1099 Amount: 0.00

Vendor ID: BUTLERCO

BUTLER COUNTY CLINIC

Description: 1
Sequence: 1
Check Type:
Chart of Account Number
01 2710 290 000 0000 0 000
CYZA BUS PHYSICAL

Checking Account ID:

Check Number:

Check Date:

Detail Description
CYZA BUS PHYSICAL
Detail Amount 150.00
Asset/Asset Tag N

Invoice Number: 218247
Amount: 150.00

Invoice Date: 12/10/2020
Due Date: 12/14/2020
Status: A
1099 Amount: 0.00

Vendor ID: CAPITAL

CAPITAL ONE

Description: 1
Sequence: 1
Check Type:
Chart of Account Number
01 2590 643 000 0000 0 000
ADOBE

Checking Account ID:

Check Number:

Check Date:

Detail Description
ADOBE
Detail Amount 32.09
Asset/Asset Tag N

Invoice Number: 121020
Amount: 32.09

Invoice Date: 12/10/2020
Due Date: 12/14/2020
Status: A
1099 Amount: 0.00

Vendor ID: CENTRAL

CENTRAL NEBRASKA REHABILITATION SERVICES

Description: 1
Sequence: 1
Check Type:
Chart of Account Number
01 2173 340 000 0000 0 000
SPED 0-2 PT

Checking Account ID:

Check Number:

Check Date:

Detail Description
SPED 0-2 PT
Detail Amount 825.92
Asset/Asset Tag N

Invoice Number: 10713
Amount: 3,953.49

Invoice Date: 12/10/2020
Due Date: 12/14/2020
Status: A
1099 Amount: 3,953.49

01 2161 340 000 0000 0 0000 SPED S.A. OT 2,518.15 N 1099 Amount: 0.00
01 2171 340 000 0000 0 0000 SPED S.A. PT 609.42 N 1099 Amount: 0.00

Vendor ID: CONNEC **CONNECTING POINT COMPUTER CENT** **PO Number: 10942** **Amount: 89.99**
Description: Invoice Date: 12/10/2020 Due Date: 12/14/2020 Status: A 1099 Amount: 0.00
Sequence: 1 Check Type: Checking Account ID: Check Number: Check Date:
Chart of Account Number Detail Description Cost Center ID Detail Amount 1099 Detail Amount Asset/Asset Tag In Full
01 2230 650 000 0000 0 0000 HP CARE PACKAGE N 89.99

Vendor ID: CONSTELLA **CONSTELLATION ENERGY** **PO Number: 3056072** **Amount: 308.82**
Description: Invoice Date: 12/10/2020 Due Date: 12/14/2020 Status: A 1099 Amount: 0.00
Sequence: 1 Check Type: Checking Account ID: Check Number: Check Date:
Chart of Account Number Detail Description Cost Center ID Detail Amount 1099 Detail Amount Asset/Asset Tag In Full
01 2610 621 000 0000 0 0000 FUEL N 308.82

Vendor ID: CROSSROADC **CROSS ROADS CONFERENCE** **PO Number: 121020** **Amount: 250.00**
Description: Invoice Date: 12/10/2020 Due Date: 12/14/2020 Status: A 1099 Amount: 0.00
Sequence: 1 Check Type: Checking Account ID: Check Number: Check Date:
Chart of Account Number Detail Description Cost Center ID Detail Amount 1099 Detail Amount Asset/Asset Tag In Full
01 2320 810 000 0000 0 0000 CRC DUES 20-21 N 250.00

Vendor ID: CUBBYSCORP **CUBBYS CORPORATE OFFICE** **PO Number: 4664885** **Amount: 1,430.07**
Description: Invoice Date: 12/10/2020 Due Date: 12/14/2020 Status: A 1099 Amount: 0.00
Sequence: 1 Check Type: Checking Account ID: Check Number: Check Date:
Chart of Account Number Detail Description Cost Center ID Detail Amount 1099 Detail Amount Asset/Asset Tag In Full
01 2610 626 000 0000 0 0000 CUSTODIAN GAS N 36.49
01 2710 626 000 0000 0 0000 BUS & VAN GAS N 1,170.21
01 2712 626 000 0000 0 0000 SPED VAN & BUS GAS N 221.98
01 1100 610 002 0040 0 0000 FLOUR FOR SCIENCE N 1.39

Vendor ID: CULLIGANYO **CULLIGAN OF YORK** **PO Number: 121020** **Amount: 98.50**
Description: Invoice Date: 12/10/2020 Due Date: 12/14/2020 Status: A 1099 Amount: 0.00
Sequence: 1 Check Type: Checking Account ID: Check Number: Check Date:
Chart of Account Number Detail Description Cost Center ID Detail Amount 1099 Detail Amount Asset/Asset Tag In Full
01 2610 610 000 0000 0 0000 WATER AND RENTAL FEE N 98.50

Vendor ID: CYZAMARK **CYZA, MARK** **PO Number: 121020** **Amount: 14.86**
Description: Invoice Date: 12/10/2020 Due Date: 12/14/2020 Status: A 1099 Amount: 0.00
Sequence: 1 Check Type: Checking Account ID: Check Number: Check Date:
Chart of Account Number Detail Description Cost Center ID Detail Amount 1099 Detail Amount Asset/Asset Tag In Full
01 2710 890 000 0000 0 0000 REIMB FOR BUS LISCENSE N 14.86

Vendor ID: DAVIDC **DAVID CITY PUBLIC SCHOOL** **PO Number: 1001,108** **Amount: 6,963.15**
Description: Invoice Date: 12/10/2020 Due Date: 12/14/2020 Status: A 1099 Amount: 0.00
Sequence: 1 Check Type: Checking Account ID: Check Number: Check Date:

Chart of Account Number Detail Description
01 6200 591 000 0000 0 000 TITLE ONE SERVICES - 1ST PAYMENT
01 1200 591 000 0000 0 000 SPED SERVICES - 1ST PAYMENT

Cost Center ID Detail Amount 1099 Detail Amount Asset/Asset Tag In Full
1,237.38 N
5,725.77 N

Vendor ID: DIETZE DIETZE MUSIC HOUSE

PO Number: **Invoice Number: 4739,4396-0,4869** **Amount: 36.51**
Invoice Date: 12/10/2020 **Due Date:** 12/14/2020 **Status:** A **1099 Amount:** 0.00

Description:
Sequence: 1 Check Type:
Chart of Account Number Checking Account ID:
01 1100 610 000 0170 0 000 INSTRUMENT SUPPLIES

Cost Center ID Detail Amount 1099 Detail Amount Asset/Asset Tag In Full
36.51 N

Vendor ID: ESU7 E.S.U. #7

PO Number: **Invoice Number: 1910** **Amount: 571.03**
Invoice Date: 12/11/2020 **Due Date:** 12/14/2020 **Status:** A **1099 Amount:** 0.00

Description:
Sequence: 1 Check Type:
Chart of Account Number Checking Account ID:
01 1100 550 002 0050 0 000 PRINTING - 5TH
01 1100 550 002 0020 0 000 PRINTING - 2ND
01 1100 550 002 0040 0 000 PRINTING - 4TH
01 2220 550 000 0000 0 000 PRINTING - LIBRARY
01 1100 550 002 0070 0 000 PRINTING - K
01 1100 550 002 0010 0 000 PRINTING - 1ST
01 1190 550 002 0000 0 000 PRINTING - PK
01 2120 550 001 0000 0 000 PRINTING - HS GUIDANCE
01 6200 550 002 0000 0 000 PRINTING - TITLE ONE

Cost Center ID Detail Amount 1099 Detail Amount Asset/Asset Tag In Full
12.57 N
213.68 N
25.52 N
61.99 N
79.08 N
74.22 N
81.79 N
0.23 N
21.95 N

Vendor ID: EAKESO EAKES OFFICE SOLUTIONS

PO Number: **Invoice Number: 81348178138045243035** **Amount: 1,088.99**
Invoice Date: 12/10/2020 **Due Date:** 12/14/2020 **Status:** A **1099 Amount:** 0.00

Description:
Sequence: 1 Check Type:
Chart of Account Number Checking Account ID:
01 2590 443 000 0000 0 000 COPIER CONTRACTS
01 2590 610 000 0000 0 000 TONER
01 2610 610 000 0000 0 000 VINYL GLOVES & DISINFECTANT

Cost Center ID Detail Amount 1099 Detail Amount Asset/Asset Tag In Full
785.28 N
59.99 N
243.72 N

Vendor ID: ESU7NETWOR EDUCATIONAL SERVICE UNIT #7

PO Number: **Invoice Number: 1262020** **Amount: 766.22**
Invoice Date: 12/11/2020 **Due Date:** 12/14/2020 **Status:** A **1099 Amount:** 0.00

Description:
Sequence: 1 Check Type:
Chart of Account Number Checking Account ID:
01 2224 382 000 0000 0 000 NETWORK NE JAN-MAR 2021
01 2230 352 000 0000 0 000 NETWORK OPERATIONS

Cost Center ID Detail Amount 1099 Detail Amount Asset/Asset Tag In Full
697.47 N
68.75 N

Vendor ID: ESU7SP EDUCATIONAL SERVICE UNIT #7

PO Number: **Invoice Number: AUG&OCT** **Amount: 50,861.13**
Invoice Date: 12/11/2020 **Due Date:** 12/14/2020 **Status:** A **1099 Amount:** 50,861.13

Description:
Sequence: 1 Check Type:
Chart of Account Number Checking Account ID:
01 6408 320 000 0000 0 000 IDEA 0-2

Cost Center ID Detail Amount 1099 Detail Amount Asset/Asset Tag In Full
4,966.28 N
4,966.28 N

01 6406 320 000 0000 0 0000 IDEA 3-4
01 1200 591 000 0000 0 0000 SPED SERVICES

6,973.69 N
38,921.16 N

Vendor ID: EGAN EGAN SUPPLY CO.

Amount: 773.04

Description:
Sequence: 1 Check Type:
Chart of Account Number
01 2610 610 000 0000 0 0000 PAPER PRODUCTS

Detail Description
N
Invoice Number: 329902
Invoice Date: 12/11/2020 Due Date: 12/14/2020 Status: A 1099 Amount: 0.00
Check Number:
Detail Amount 1099 Detail Amount Asset/Asset Tag
773.04 N In Full

Vendor ID: FIRSTBOOK FIRST BOOK
Description:
Sequence: 1 Check Type:
Chart of Account Number
01 2220 640 000 0000 0 0000 LIBRARY BOOKS

Amount: 151.69

Detail Description
N
Invoice Number: 700337235
Invoice Date: 12/11/2020 Due Date: 12/14/2020 Status: A 1099 Amount: 0.00
Check Number:
Detail Amount 1099 Detail Amount Asset/Asset Tag
151.69 N In Full

Vendor ID: FLINN FLINN SCIENTIFIC INC.
Description:
Sequence: 1 Check Type:
Chart of Account Number
01 1100 739 001 0145 0 0000 HOT PLATES FOR HS SCIENCE

Amount: 2,800.00

Detail Description
N
Invoice Number: 2522453
Invoice Date: 12/11/2020 Due Date: 12/14/2020 Status: A 1099 Amount: 0.00
Check Number:
Detail Amount 1099 Detail Amount Asset/Asset Tag
2,800.00 N In Full

Vendor ID: PETTY GENERAL FUND-PETTY CASH
Description:
Sequence: 1 Check Type:
Chart of Account Number
01 1100 610 002 0040 0 0000 4TH GRADE SUPPLIES

Amount: 46.00

Detail Description
N
Invoice Number: 121120
Invoice Date: 12/11/2020 Due Date: 12/14/2020 Status: A 1099 Amount: 0.00
Check Number:
Detail Amount 1099 Detail Amount Asset/Asset Tag
46.00 N In Full

Vendor ID: HOMETO HOMETOWN LEASING
Description:
Sequence: 1 Check Type:
Chart of Account Number
01 2590 443 000 0000 0 0000 COPIER PAYMENT

Amount: 431.27

Detail Description
N
Invoice Number: 121020
Invoice Date: 12/11/2020 Due Date: 12/14/2020 Status: A 1099 Amount: 0.00
Check Number:
Detail Amount 1099 Detail Amount Asset/Asset Tag
431.27 N In Full

Vendor ID: JACKSO JACKSON SERVICES, INC
Description:
Sequence: 1 Check Type:
Chart of Account Number
01 2610 420 000 0000 0 0000 MOPS & RUGS

Amount: 395.50

Detail Description
N
Invoice Number: 44192284428136
Invoice Date: 12/11/2020 Due Date: 12/14/2020 Status: A 1099 Amount: 0.00
Check Number:
Detail Amount 1099 Detail Amount Asset/Asset Tag
395.50 N In Full

Vendor ID: JJZAK JJ & ZAK
Description:
Sequence: 1 Check Type:
Chart of Account Number
01 2213 330 000 0000 0 0000 ICU DATABASE CUSTOM PROGRAMMING

Amount: 400.00

Detail Description
N
Invoice Number: 121020
Invoice Date: 12/11/2020 Due Date: 12/14/2020 Status: A 1099 Amount: 0.00
Check Number:
Detail Amount 1099 Detail Amount Asset/Asset Tag
400.00 N In Full

Vendor ID: JOSTENS	JOSTENS	PO Number:	Invoice Number: 25247716	Amount:
Description:		Invoice Date: 12/11/2020	Due Date: 12/14/2020	Status: A 1099 Amount: 0.00
Sequence: 1	Check Type:	Check Number:	Check Date:	
<u>Chart of Account Number</u>	<u>Detail Description</u>	<u>Detail Amount</u>	<u>1099 Detail Amount</u>	<u>Asset/Asset Tag</u>
01 2490 610 000 0000 0 000	DIPLOMAS	358.28	N	In Full
Vendor ID: KSBOSCHLAW	KSB SCHOOL LAW, PC, LLO	PO Number:	Invoice Number: 9250	Amount:
Description:		Invoice Date: 12/11/2020	Due Date: 12/14/2020	Status: A 1099 Amount: 1,764.00
Sequence: 1	Check Type:	Check Number:	Check Date:	
<u>Chart of Account Number</u>	<u>Detail Description</u>	<u>Detail Amount</u>	<u>1099 Detail Amount</u>	<u>Asset/Asset Tag</u>
01 2330 317 000 0000 0 000	LEGAL SERVICES	1,764.00	N	In Full
Vendor ID: LINGO	LINGO	PO Number:	Invoice Number: 121020	Amount:
Description:		Invoice Date: 12/11/2020	Due Date: 12/14/2020	Status: A 1099 Amount: 0.00
Sequence: 1	Check Type:	Check Number:	Check Date:	
<u>Chart of Account Number</u>	<u>Detail Description</u>	<u>Detail Amount</u>	<u>1099 Detail Amount</u>	<u>Asset/Asset Tag</u>
01 2590 530 000 0000 0 000	LONG DISTANCE	264.70	N	In Full
Vendor ID: MODOORPROD	M & O DOOR PRODUCTS	PO Number:	Invoice Number: 00970770097306	Amount:
Description:		Invoice Date: 12/11/2020	Due Date: 12/14/2020	Status: A 1099 Amount: 0.00
Sequence: 1	Check Type:	Check Number:	Check Date:	
<u>Chart of Account Number</u>	<u>Detail Description</u>	<u>Detail Amount</u>	<u>1099 Detail Amount</u>	<u>Asset/Asset Tag</u>
01 2620 430 000 0000 0 000	INSTALLED NEW DOOR & FRAME, YALE	3,470.65	N	In Full
Vendor ID: MATHESON	MATHESON TRI-GAS INC.	PO Number:	Invoice Number: 51722852	Amount:
Description:		Invoice Date: 12/11/2020	Due Date: 12/14/2020	Status: A 1099 Amount: 0.00
Sequence: 1	Check Type:	Check Number:	Check Date:	
<u>Chart of Account Number</u>	<u>Detail Description</u>	<u>Detail Amount</u>	<u>1099 Detail Amount</u>	<u>Asset/Asset Tag</u>
01 1100 610 001 0180 0 000	GAS FOR SHOP	897.90	N	In Full
Vendor ID: MENARD	MENARDS	PO Number:	Invoice Number: 30066	Amount:
Description:		Invoice Date: 12/11/2020	Due Date: 12/14/2020	Status: A 1099 Amount: 0.00
Sequence: 1	Check Type:	Check Number:	Check Date:	
<u>Chart of Account Number</u>	<u>Detail Description</u>	<u>Detail Amount</u>	<u>1099 Detail Amount</u>	<u>Asset/Asset Tag</u>
01 2710 610 000 0000 0 000	PAPER TOWELS & HOSE CUTTER	47.92	N	In Full
Vendor ID: MIDAME	MID-AMERICAN RESEARCH CHEMICAL	PO Number:	Invoice Number: 0716751	Amount:
Description:		Invoice Date: 12/11/2020	Due Date: 12/14/2020	Status: A 1099 Amount: 0.00
Sequence: 1	Check Type:	Check Number:	Check Date:	
<u>Chart of Account Number</u>	<u>Detail Description</u>	<u>Detail Amount</u>	<u>1099 Detail Amount</u>	<u>Asset/Asset Tag</u>
01 2610 610 000 0000 0 000	RING B GONE	114.00	N	In Full
Vendor ID: MIDWESTALA	MIDWEST ALARM SERVICES	PO Number:	Invoice Number: 335416	Amount:
Description:		Invoice Date: 12/11/2020	Due Date: 12/14/2020	Status: A 1099 Amount: 0.00
Sequence: 1	Check Type:	Check Number:	Check Date:	

<u>Chart of Account Number</u> 01 2670 352 000 0000 0 000	<u>Detail Description</u> FIRE ALARM MONITORING DEC-FEB 2021	<u>Cost Center ID</u> 122.37	<u>Detail Amount</u> 122.37	<u>1099 Detail Amount</u> N	<u>Asset/Asset Tag</u> N	<u>In Full</u>
Vendor ID: NAPA AUTO	NAPA AUTO AND TRUCK PARTS	PO Number:	Invoice Number: 689731	Invoice Date: 12/11/2020	Due Date: 12/14/2020	Amount: 89.90
Description:	Checking Account ID:	Invoice Date: 12/11/2020	Due Date: 12/14/2020	Status: A	1099 Amount: 0.00	
Sequence: 1	Check Type:	Check Number:	Check Date:			
<u>Chart of Account Number</u> 01 2710 610 000 0000 0 000	<u>Detail Description</u> HD 50 50, ICE SCRAPERS	<u>Cost Center ID</u> 89.90	<u>Detail Amount</u> 89.90	<u>1099 Detail Amount</u> N	<u>Asset/Asset Tag</u> N	<u>In Full</u> Incomplete
Vendor ID: NESAFE	NE SAFETY CENTER	PO Number:	Invoice Number: 57-8298	Invoice Date: 12/11/2020	Due Date: 12/14/2020	Amount: 2,025.00
Description:	Checking Account ID:	Invoice Date: 12/11/2020	Due Date: 12/14/2020	Status: A	1099 Amount: 0.00	
Sequence: 1	Check Type:	Check Number:	Check Date:			
<u>Chart of Account Number</u> 01 2710 330 000 0000 0 000	<u>Detail Description</u> LEVEL 1 PUPIL TRANSPORTATION COURSE	<u>Cost Center ID</u> 2,025.00	<u>Detail Amount</u> 2,025.00	<u>1099 Detail Amount</u> N	<u>Asset/Asset Tag</u> N	<u>In Full</u>
Vendor ID: OCCUPHEALT	OCCUPATIONAL HEALTH SERVICES	PO Number:	Invoice Number: 68668	Invoice Date: 12/11/2020	Due Date: 12/14/2020	Amount: 223.00
Description:	Checking Account ID:	Invoice Date: 12/11/2020	Due Date: 12/14/2020	Status: A	1099 Amount: 0.00	
Sequence: 1	Check Type:	Check Number:	Check Date:			
<u>Chart of Account Number</u> 01 2710 290 000 0000 0 000	<u>Detail Description</u> BUS DRIVER DRUG SCREENING	<u>Cost Center ID</u> 223.00	<u>Detail Amount</u> 223.00	<u>1099 Detail Amount</u> N	<u>Asset/Asset Tag</u> N	<u>In Full</u>
Vendor ID: ONESOURCE	ONE SOURCE	PO Number:	Invoice Number: 2307-220201130	Invoice Date: 12/11/2020	Due Date: 12/14/2020	Amount: 5.00
Description:	Checking Account ID:	Invoice Date: 12/11/2020	Due Date: 12/14/2020	Status: A	1099 Amount: 0.00	
Sequence: 1	Check Type:	Check Number:	Check Date:			
<u>Chart of Account Number</u> 01 2590 340 000 0000 0 000	<u>Detail Description</u> BACKGROUND CHECK	<u>Cost Center ID</u> 5.00	<u>Detail Amount</u> 5.00	<u>1099 Detail Amount</u> N	<u>Asset/Asset Tag</u> 0.00 N	<u>In Full</u>
Vendor ID: ORKINP	ORKIN PEST CONTROL	PO Number:	Invoice Number: 206008332	Invoice Date: 12/11/2020	Due Date: 12/14/2020	Amount: 91.17
Description:	Checking Account ID:	Invoice Date: 12/11/2020	Due Date: 12/14/2020	Status: A	1099 Amount: 0.00	
Sequence: 1	Check Type:	Check Number:	Check Date:			
<u>Chart of Account Number</u> 01 2610 420 000 0000 0 000	<u>Detail Description</u> PEST CONTROL	<u>Cost Center ID</u> 91.17	<u>Detail Amount</u> 91.17	<u>1099 Detail Amount</u> N	<u>Asset/Asset Tag</u> N	<u>In Full</u>
Vendor ID: PAYFLEX	PAY FLEX	PO Number:	Invoice Number: 121020	Invoice Date: 12/11/2020	Due Date: 12/14/2020	Amount: 100.00
Description:	Checking Account ID:	Invoice Date: 12/11/2020	Due Date: 12/14/2020	Status: A	1099 Amount: 0.00	
Sequence: 1	Check Type:	Check Number:	Check Date:			
<u>Chart of Account Number</u> 01 1100 291 000 0000 0 000	<u>Detail Description</u> ADMIN FEE	<u>Cost Center ID</u> 100.00	<u>Detail Amount</u> 100.00	<u>1099 Detail Amount</u> N	<u>Asset/Asset Tag</u> N	<u>In Full</u>
Vendor ID: PEKNY	PEKNY & ASSOCIATES	PO Number:	Invoice Number: 44258	Invoice Date: 12/11/2020	Due Date: 12/14/2020	Amount: 8,150.00
Description:	Checking Account ID:	Invoice Date: 12/11/2020	Due Date: 12/14/2020	Status: A	1099 Amount: 0.00	
Sequence: 1	Check Type:	Check Number:	Check Date:			
<u>Chart of Account Number</u> 01 2310 315 000 0000 0 000	<u>Detail Description</u> AUDIT, AFR, ADM	<u>Cost Center ID</u> 8,150.00	<u>Detail Amount</u> 8,150.00	<u>1099 Detail Amount</u> N	<u>Asset/Asset Tag</u> N	<u>In Full</u>

Vendor ID: PINNACLEOM	PINNACLE BANK	PO Number:	Invoice Number: 121020	Amount:
Description:	Checking Account ID:	Invoice Date: 12/11/2020	Due Date: 12/14/2020	Status: A 1099 Amount: 0.00
Sequence: 1	Check Type:	Check Number:	Check Date:	
<u>Chart of Account Number</u>	<u>Detail Description</u>	<u>Detail Amount</u>	<u>1099 Detail Amount</u>	<u>Asset/Asset Tag</u>
01 2710 643 000 0000 0 000	EASY ATTENDANCE APP	13.36	N	In Full
01 2710 610 000 0000 0 000	BOOSTER SEATS FOR VANS	146.32	N	
01 2410 890 002 0000 0 000	DONUTS & MATERIALS FOR VETERAN WREATHS	308.98	N	
01 2590 643 000 0000 0 000	BAMBOO	365.00	N	
Vendor ID: PITBOW	PITNEY BOWES	PO Number:	Invoice Number: 33124470551	Amount:
Description:	Checking Account ID:	Invoice Date: 12/11/2020	Due Date: 12/14/2020	Status: A 1099 Amount: 0.00
Sequence: 1	Check Type:	Check Number:	Check Date:	
<u>Chart of Account Number</u>	<u>Detail Description</u>	<u>Detail Amount</u>	<u>1099 Detail Amount</u>	<u>Asset/Asset Tag</u>
01 2590 443 000 0000 0 000	POSTAGE MACHINE LEASE PAYMENT	210.96	N	In Full
Vendor ID: POLKORPP	POLK CO. RURAL PUBLIC POWER DISTRICT	PO Number:	Invoice Number: 121020	Amount:
Description:	Checking Account ID:	Invoice Date: 12/11/2020	Due Date: 12/14/2020	Status: A 1099 Amount: 0.00
Sequence: 1	Check Type:	Check Number:	Check Date:	
<u>Chart of Account Number</u>	<u>Detail Description</u>	<u>Detail Amount</u>	<u>1099 Detail Amount</u>	<u>Asset/Asset Tag</u>
01 2610 621 000 0000 0 000	ELECTRICITY	12,929.61	N	In Full
Vendor ID: POLKC5	POLK COUNTY NEWS	PO Number:	Invoice Number: 27239	Amount:
Description:	Checking Account ID:	Invoice Date: 12/11/2020	Due Date: 12/14/2020	Status: A 1099 Amount: 0.00
Sequence: 1	Check Type:	Check Number:	Check Date:	
<u>Chart of Account Number</u>	<u>Detail Description</u>	<u>Detail Amount</u>	<u>1099 Detail Amount</u>	<u>Asset/Asset Tag</u>
01 2310 540 000 0000 0 000	BOARD MINUTES	114.84	N	In Full
Vendor ID: RCPITSTOP	RC PIT STOP	PO Number:	Invoice Number: 805516	Amount:
Description:	Checking Account ID:	Invoice Date: 12/11/2020	Due Date: 12/14/2020	Status: A 1099 Amount: 0.00
Sequence: 1	Check Type:	Check Number:	Check Date:	
<u>Chart of Account Number</u>	<u>Detail Description</u>	<u>Detail Amount</u>	<u>1099 Detail Amount</u>	<u>Asset/Asset Tag</u>
01 2410 890 002 0000 0 000	LUNCH WITH THE PRINCIPAL	91.31	N	In Full
Vendor ID: SAVVASLEAR	SAVVAS LEARNING COMPANY LLC	PO Number:	Invoice Number: 70027366898	Amount:
Description:	Checking Account ID:	Invoice Date: 12/11/2020	Due Date: 12/14/2020	Status: A 1099 Amount: 0.00
Sequence: 1	Check Type:	Check Number:	Check Date:	
<u>Chart of Account Number</u>	<u>Detail Description</u>	<u>Detail Amount</u>	<u>1099 Detail Amount</u>	<u>Asset/Asset Tag</u>
01 1100 640 000 0000 0 000	SCIENCE MATERIALS	3,707.30	N	In Full
Vendor ID: SCHOSP	SCHOOL SPECIALITY	PO Number:	Invoice Number: 2081265688229	Amount:
Description:	Checking Account ID:	Invoice Date: 12/11/2020	Due Date: 12/14/2020	Status: A 1099 Amount: 0.00
Sequence: 1	Check Type:	Check Number:	Check Date:	
<u>Chart of Account Number</u>	<u>Detail Description</u>	<u>Detail Amount</u>	<u>1099 Detail Amount</u>	<u>Asset/Asset Tag</u>
01 2410 610 002 0000 0 000	KIDS AT WORK ENVELOPES	200.98	N	In Full

BUDGET REPORT

11/2020

NOVEMBER 2020 GENERAL FUND

Account Number	Account Description	BUDGETED	EXPENDED	TO DATE	BALANCE OF EOM
01	GENERAL FUND				
1100	REGULAR INSTRUCTIONAL PROGRAMS				
1100	REGULAR INSTRUCTIONAL PROGRAMS	\$3,058,492.00	\$247,460.31	\$764,541.77	\$2,293,950.23
1150	ENGLISH LANGUAGE LEARNERS	\$29,921.00	\$4,302.61	\$12,945.17	\$16,975.83
1160	POVERTY - After School Program	\$101,700.00	\$2,389.46	\$11,154.22	\$90,545.78
1190	PRESCHOOL	\$118,166.00	\$9,287.38	\$27,903.13	\$90,262.87
1100	REGULAR INSTRUCTIONAL PROGRAMS	\$3,308,279.00	\$263,439.76	\$816,544.29	\$2,491,734.71
1200	SPECIAL EDUCATION PROGRAMS				
1200	SPECIAL EDUCATION PROGRAMS	\$521,688.00	\$56,185.87	\$123,224.17	\$398,463.83
1291	SPED AGES 3-5	\$65,712.00	\$0.00	\$0.00	\$65,712.00
1292	SPED AGES 0-2	\$16,000.00	\$0.00	\$0.00	\$16,000.00
1295	UNIFIED SPORTS	\$1,700.00	\$1,056.52	\$1,056.52	\$643.48
1200	SPECIAL EDUCATION PROGRAMS	\$605,100.00	\$57,242.39	\$124,280.69	\$480,819.31
2100	SUPPORTIVE SERVICES PUPILS				
2120	GUIDANCE SERVICES	\$202,931.00	\$15,464.21	\$49,885.88	\$153,045.12
2130	HEALTH SERVICES	\$63,600.00	\$4,827.32	\$14,821.90	\$48,778.10
2141	SPED Psychological services - Age S.A.	\$45,454.00	\$0.00	\$0.00	\$45,454.00
2151	SPEECH PATHOLOGY - SPED SCHOOL AGE	\$101,657.00	\$7,285.56	\$23,648.27	\$78,008.73
2161	SPED Occupational Therapy - Age S.A.	\$12,000.00	\$1,643.26	\$3,771.33	\$8,228.67
2171	SPED Physical Therapy - Age S.A.	\$10,000.00	\$576.35	\$1,494.21	\$8,505.79
2173	SPED Physical Therapy - Age 0-2	\$0.00	\$377.99	\$773.63	(\$773.63)
2100	SUPPORTIVE SERVICES PUPILS	\$435,642.00	\$30,174.69	\$94,395.22	\$341,246.78
2200	SUPPORT SERVICES STAFF				
2211	SCHOOL IMPROVEMENT	\$12,200.00	\$176.87	\$530.43	\$11,669.57
2212	INST STAFF TRNG AND CURR DEV	\$1,950.00	\$0.00	\$0.00	\$1,950.00
2213	INSTRUCTIONAL STAFF TRAINING	\$10,000.00	\$0.00	\$3,284.56	\$6,715.44
2214	IMPLEMENTATION OF STANDARDS	\$5,500.00	\$141.03	\$141.03	\$5,358.97
2220	LIBRARY/MEDIA SERVICE	\$112,663.00	\$8,688.62	\$24,860.93	\$87,802.07
2224	EDUCATIONAL TV SERVICES	\$7,000.00	\$0.00	\$722.47	\$6,277.53
2230	INSTRUCTION RELATED TECHNOLOGY	\$129,912.00	\$11,789.67	\$33,285.12	\$96,626.88
2240	ACADEMIC STUDENT ASSESSMENT	\$9,750.00	\$0.00	\$0.00	\$9,750.00
2200	SUPPORT SERVICES STAFF	\$288,975.00	\$20,796.19	\$62,824.54	\$226,150.46
2300	SUPPORT SERVICES-GEN ADMIN				
2310	BOARD OF EDUCATION	\$47,900.00	\$8,064.09	\$23,222.17	\$24,677.83
2320	EXECUTIVE ADMINISTRATION	\$150,700.00	\$13,007.63	\$37,228.89	\$113,471.11
2330	DISTRICT LEGAL SERVICES	\$20,000.00	\$0.00	\$144.50	\$19,855.50
2300	SUPPORT SERVICES-GEN ADMIN	\$218,600.00	\$21,071.72	\$60,595.56	\$158,004.44
2400	OFFICE OF PRINCIPAL				
2410	OFFICE OF THE PRINCIPAL	\$267,302.00	\$21,286.50	\$66,872.68	\$200,429.32
2400	OFFICE OF PRINCIPAL	\$267,302.00	\$21,286.50	\$66,872.68	\$200,429.32
2500	SUPPORT SERVICES-BUSINESS				
2590	GENERAL ADMIN - BUSINESS SERVICE	\$284,100.00	\$21,023.29	\$65,026.39	\$219,073.61
2500	SUPPORT SERVICES-BUSINESS	\$284,100.00	\$21,023.29	\$65,026.39	\$219,073.61
2600	SUPPORT SERVICES-BLDGS & SITES				
2610	OPERATION OF PLANT	\$517,200.00	\$26,123.90	\$123,279.35	\$393,920.65
2620	MAINTENANCE OF PLANT	\$87,500.00	\$4,028.06	\$6,886.97	\$80,613.03
2650	GENERAL PURPOSE VEHICLES	\$2,800.00	\$0.00	\$1,806.00	\$994.00
2660	SECURITY	\$5,100.00	\$0.00	\$0.00	\$5,100.00
2670	SCHOOL SAFETY	\$3,500.00	\$258.65	\$859.29	\$2,640.71
2600	SUPPORT SERVICES-BLDGS & SITES	\$616,100.00	\$30,410.61	\$132,831.61	\$483,268.39
2700	SUPPORT SERVICES-PUPIL TRANS				
2710	Pupil Transportation - Regular ED	\$196,500.00	\$18,039.06	\$62,229.07	\$134,270.93
2712	SCHOOL AGE SPEC ED TRANSPORT	\$76,550.00	\$1,181.21	\$2,840.06	\$73,709.94
2700	SUPPORT SERVICES-PUPIL TRANS	\$273,050.00	\$19,220.27	\$65,069.13	\$207,980.87
3500	Other State Categorical Programs				
3500	Other State Categorical Programs	\$0.00	\$0.00	\$0.00	\$0.00
3535	HIGH ABILITY	\$4,000.00	\$0.00	\$0.00	\$4,000.00
3500	Other State Categorical Programs	\$4,000.00	\$0.00	\$0.00	\$4,000.00
4500	BUILDING CONSTRUCTION				
4500	BUILDING CONSTRUCTION	\$60,000.00	\$0.00	\$0.00	\$60,000.00
4599	ARRA STABILIZATION	\$0.00	\$0.00	\$0.00	\$0.00
4500	BUILDING CONSTRUCTION	\$60,000.00	\$0.00	\$0.00	\$60,000.00
4600	SITE IMPROVEMENTS				
4600	SITE IMPROVEMENTS	\$10,000.00	\$0.00	\$0.00	\$10,000.00

4630	ARRA 3-5 EXPENSES	\$0.00	\$0.00	\$0.00	\$0.00
4600	SITE IMPROVEMENTS	<u>\$10,000.00</u>	<u>\$0.00</u>	<u>\$0.00</u>	<u>\$10,000.00</u>
6200	TITLE I				
6200	TITLE I	\$128,017.00	\$9,832.77	\$31,442.21	\$96,574.79
6200	TITLE I	<u>\$128,017.00</u>	<u>\$9,832.77</u>	<u>\$31,442.21</u>	<u>\$96,574.79</u>
6400	6400				
6406	IDEA 3-5 SPED	\$3,459.00	\$5,473.95	\$5,473.95	(\$2,014.95)
6408	IDEA PART B 0-21	\$83,031.00	\$2,449.32	\$2,449.32	\$80,581.68
6400	6400	<u>\$86,490.00</u>	<u>\$7,923.27</u>	<u>\$7,923.27</u>	<u>\$78,566.73</u>
6900	6900				
6992	REAP - FEDERAL SERVICES	\$30,806.00	\$0.00	\$0.00	\$30,806.00
6900	6900	<u>\$30,806.00</u>	<u>\$0.00</u>	<u>\$0.00</u>	<u>\$30,806.00</u>
8000	TRANSFERS				
8000	TRANSFERS	\$25,000.00	\$0.00	\$0.00	\$25,000.00
8000	TRANSFERS	<u>\$25,000.00</u>	<u>\$0.00</u>	<u>\$0.00</u>	<u>\$25,000.00</u>
01	GENERAL FUND	<u>\$6,641,461.00</u>	<u>\$502,421.46</u>	<u>\$1,527,805.59</u>	<u>\$5,113,655.41</u>

Revenue Summary Report
 Processing Month:
NOVEMBER 2020 GENERAL FUND

Fund: 01 GENERAL FUND					
<u>Account Number</u>	<u>Description</u>	<u>During Month</u>	<u>To Date</u>	<u>% of Budget</u>	<u>Budget Balance</u>
01 1100	LEVIED TAXES	40,683.29	1,415,999.15	0.00	(1,415,999.15)
01 1115	CARLINE TAX	0.00	715.69	0.00	(715.69)
01 1120	PUBLIC POWER DIST. TAX	3,428.17	5,886.23	0.00	(5,886.23)
01 1125	MOTOR VEHICLES TAX	11,852.18	53,117.56	0.00	(53,117.56)
01 1140	INTEREST	943.63	2,187.47	0.00	(2,187.47)
01 1370	PRESCHOOL TUITION	0.00	737.50	0.00	(737.50)
01 1510	INTEREST ON INVESTMENT	93.86	287.71	0.00	(287.71)
01 1990	OTHER LOCAL RECEIPTS	210.32	752.64	0.00	(752.64)
Subtotal: LOCAL RECIEPTS		57,211.45	1,479,683.95	0.00	(1,479,683.95)
01 2110	FINES & LICENSE FEES	33,543.80	35,556.29	0.00	(35,556.29)
01 2210	ESU RECEIPTS	150.00	322.89	0.00	(322.89)
Subtotal: COUNTY AND ESU RECEIPTS		33,693.80	35,879.18	0.00	(35,879.18)
01 3110	STATE AID	64,590.00	193,770.00	0.00	(193,770.00)
01 3180	PRO-RATA MOTOR VEHICLE	0.00	1,350.84	0.00	(1,350.84)
01 3535	HIGH ABILITY LEARNERS	0.00	2,342.00	0.00	(2,342.00)
Subtotal: STATE RECEIPTS		64,590.00	197,462.84	0.00	(197,462.84)
01 4516	IDEA 4406	0.00	3,426.00	0.00	(3,426.00)
01 4708	MEDICAID	1,980.57	1,980.57	0.00	(1,980.57)
Subtotal: FEDERAL RECEIPTS		1,980.57	5,406.57	0.00	(5,406.57)
01 5301	INSURANCE ADJUSTMENTS	0.00	2,827.11	0.00	(2,827.11)
01 5690	OTHER NON-REVENUE RECEIPTS	0.00	43,730.70	0.00	(43,730.70)
Subtotal: NON-REVENUE RECEIPTS		0.00	46,557.81	0.00	(46,557.81)
Grand Total:		157,475.82	1,764,990.35	0.00	(1,764,990.35)

SHELBY - RISING CITY PUBLIC SCHOOL
FINANCIAL REPORT
GENERAL FUND

Balance: 11/1/20 \$ 2,327,400.19

RECEIPTS:

Polk Co Treas. - Motor Vehicle	\$	6,550.90
Polk Co Treas. - Levied	\$	11,828.43
Polk Co Treas. - Interest	\$	225.44
Polk Co Treas. - Fines & Lisc	\$	979.87
Butler Co Treas. - Motor Vehicle	\$	5,301.28
Butler Co Treas. - Levied	\$	28,854.86
Butler Co Treas. - Interest	\$	718.19
Butler Co Treas. - 5% Gross	\$	3,428.17
Butler Co Treas. - Fines & Lisc	\$	32,263.93
Savings - Interest	\$	0.37
State of NE - Medicaid	\$	1,980.57
Village of Shelby - Library Expenses	\$	210.32
Village of Surprise - Liq. License	\$	300.00
Petty Cash - Interest	\$	0.29
ESU 7 - Title IX	\$	150.00
State of NE - State Aid	\$	64,590.00
Bank - Interest	\$	93.20
SRC Lunch Fund - Salaries	\$	7,523.36

Total Receipts: \$ 164,999.18

DISBURSEMENTS:

Pay Roll	\$	418,881.19
Invoices	\$	91,063.63

Total Disbursements: \$ 509,944.82

Balance: 11/30/20 \$ 1,982,454.55

Savings Account \$ 9,035.76

Total General Fund Assets 11/30/20 \$ 1,991,490.31

**SHELBY - RISING CITY PUBLIC SCHOOLS
FINANCIAL REPORT
NUTRITION FUND**

Beginning Balance 11/01/20

\$ 73,506.03

RECEIPTS:

	AMOUNT
Family Receipts	\$ 728.00
Lunch Payments Online	\$ 30.00
State of NE Reimbursements	\$ 26,810.70
Other Lunch Payments	\$ 125.00
Interest	<u>\$ 3.20</u>
<u>Total Receipts</u>	<u>\$ 27,696.90</u>

DISBURSEMENTS:

Name:	Ck No.	AMOUNT
US Foods	2909	\$ 3,673.31
Bimbo Bakeries USA	2910	\$ 932.24
Hiland Dairy	2911	\$ 2,393.88
Cash-Wa Distributing	2912	\$ 12,314.62
Cubby's	2913	\$ 81.28
SRC General Fund	2914	\$ 7,523.36
Magic Wrighter	5579	\$ 20.00

Total Expenditures **\$ 26,938.69**

Ending Balance 11/30/20

\$ 74,264.24

**SHELBY-RISING CITY PUBLIC SCHOOL
FINANCIAL REPORT
BUILDING FUND**

Balance 11/01/20 \$ 138,148.45

RECEIPTS:

Polk Co	\$	500.10
Butler Co	\$	1,369.14
Interest	\$	5.92

Total Receipts: \$ 1,875.16

DISBURSEMENTS:

Total Disbursements: \$ -

Balance: 11/30/20 \$ 140,023.61

**SHELBY- RISING CITY PUBLIC SCHOOL
FINANCIAL REPORT
DEPRECIATION FUND
November 30, 2020**

Beginning Balance: \$ 272,207.08

RECEIPTS:

Interest \$ 57.80

Total Receipts: \$ 57.80

DISBURSEMENTS:

Total Disbursements:

Ending Balance: \$ 272,264.88

Certificate of Deposit \$ 172,000.00

Total Depreciation and Certificate of Deposit \$ 444,264.88

**SHELBY-RISING CITY PUBLIC SCHOOL
FINANCIAL REPORT
GENERAL FUND - BOND**

Balance 11/01/20 \$ 863,341.78

RECEIPTS:

Polk Co. Treas.	\$	2,302.14
Butler Co. Treas.	\$	6,302.80
Interest	\$	36.12

Total Receipts: \$ 8,641.06

DISBURSEMENTS:

BOK Financial(wired funds)	\$	40,508.47
Wired out going fees	\$	15.00
BOK Financial	\$	217,450.00
BOK Financial	\$	489,510.83

Total Disbursements: \$ 747,484.30

Balance: 11/30/20 \$ 124,498.54

SUMMARY SHEET

November 30, 2020

Account Name:	Amount	Amount to CD
General Fund	\$ 1,982,454.55	
General Fund Savings Account	\$ 9,035.76	
Lunch Fund	\$ 74,264.24	
Petty Cash	\$ 11,350.51	
Building	\$ 140,023.61	
Depreciaton	\$ 272,264.88	\$ 172,000.00
Employment Benefit	\$ 16,401.90	
Bond	\$ 124,498.54	
Activity Fund	\$ 100,717.23	\$ 38,000.00
<u>Total of Accounts</u>	<u>\$ 2,731,011.22</u>	<u>\$ 210,000.00</u>
<u>Total of Above Accounts</u>		<u>\$ 2,941,011.22</u>

SHELBY-RISING CITY PUBLIC SCHOOL
FINANCIAL REPORT
ACTIVITY FUND

Balance: **11/1/20 \$ 133,611.09**

RECEIPTS:

 Total Receipts \$ 16,407.06

Total Receipts: \$ 16,407.06

DISBURSEMENTS:

 Total Disbursements \$ 11,300.92

Total Disbursements: \$ 11,300.92

Balance: **11/30/20 \$ 138,717.23**

Balance of Account:	\$ 138,717.23
Certificate of Deposit at Pinnacle Bank	\$ 38,000.00
Total in Acitivity Fund Checking	\$ 100,717.23

Account Number	Description	Previous Balance	Current Month	Ending Balance
Fund: 05 ACTIVITIES FUND				
<u>Current Assets</u>				
05 101	CASH/ACTIVITY FUND	133,677.97	5,076.14	138,754.11
	Current Assets Subtotal:	133,677.97	5,076.14	138,754.11
Total Assets and Deferred Outflows of Resources:		133,677.97	5,076.14	138,754.11

<u>Fund Balance</u>				
05 704 0434	FUND BALANCE/CD	299.00	0.00	299.00
05 704 4010	FUND BALANCE - ATHLETICS	8,235.16	(3,472.27)	4,762.89
05 704 4020	FUND BALANCE - CONCESSION	1,824.78	(257.30)	1,567.48
05 704 4030	FUND BALANCE - NHS	963.64	0.00	963.64
05 704 4040	FUND BALANCE - SRC CLUB	5,539.35	0.00	5,539.35
05 704 4050	FUND BALANCE - CLASS OF 2023	2,251.19	0.00	2,251.19
05 704 4060	FUND BALANCE - CLASS OF 2021	2,757.74	(74.22)	2,683.52
05 704 4070	FUND BALANCE - JUST FOR KIDS	1,315.95	0.00	1,315.95
05 704 4080	FUND BALANCE - CLASS OF 2020	505.00	0.00	505.00
05 704 4090	FUND BALANCE - CLASS OF 2022	4,060.19	0.00	4,060.19
05 704 4100	FUND BALANCE - YEARBOOK	757.18	1,900.00	2,657.18
05 704 4110	FUND BALANCE - MUSIC	96.70	0.00	96.70
05 704 4120	FUND BALANCE - STUDENT COUNCIL	5,437.52	(7.99)	5,429.53
05 704 4130	FUND BALANCE - DANCE TEAM	479.17	0.00	479.17
05 704 4140	FUND BALANCE - MEMORIALS	2,780.28	50.00	2,830.28
05 704 4150	FUND BALANCE - DRUG & ALCHOL PREVENTION	2,596.52	0.00	2,596.52
05 704 4160	FUND BALANCE - SHOP	10,360.89	0.00	10,360.89
05 704 4170	FUND BALANCE - INTEREST	529.42	9.08	538.50
05 704 4180	FUND BALANCE - BOOK IT	556.76	0.00	556.76
05 704 4190	FUND BALANCE/SPEECH AND DRAMA	(128.25)	(173.62)	(301.87)
05 704 4200	FUND BALANCE - LAP TOP LEASE FEE	9,449.11	0.00	9,449.11
05 704 4210	FUND BALANCE - WELLNESS CENTER	20,784.92	(1,228.65)	19,556.27
05 704 4220	FUND BALANCE - FBLA	5,750.52	850.00	6,600.52
05 704 4230	FUND BALANCE - STAFF DEVELOPMENT	(16.20)	(92.99)	(109.19)
05 704 4240	FUND BALANCE - QUIZ BOWL	20.00	0.00	20.00
05 704 4250	FUND BALANCE - ALUMNI	1,141.01	0.00	1,141.01
05 704 4260	FUND BALANCE - VIDEO BOARD	8,554.87	0.00	8,554.87
05 704 4270	FUND BALANCE - FFA	16,700.12	7,522.63	24,222.75
05 704 4280	FUND BALANCE - CIRCLE OF FRIENDS	67.14	0.00	67.14
05 704 4290	FUND BALANCE - STUDENT FEES	10,994.00	(125.41)	10,868.59
05 704 4300	FUND BALANCE - FACILITY RENTAL	1,290.00	0.00	1,290.00
05 704 4310	FUND BALANCE - SUPERINTENDENT	7,287.37	(48.12)	7,239.25
05 704 4320	FUND BALANCE - UNIFIED BOWLING	436.92	225.00	661.92
	Fund Balance Subtotal:	133,677.97	5,076.14	138,754.11
Total Liabilities, Deferred Inflows of Resources, and Fund Equity:		133,677.97	5,076.14	138,754.11

38,000
 100,754.11

Invoice Listing - Detail

Batch Description:	NOVEMBER 2020, ACTIVITY FUND INVOICES	Processing Month:	11/2020	Credit Card Vendor ID:	End of Fiscal Year Expense Invoices:
Vendor ID: 2NDWIND	2ND WIND EXERCISE EQUIPMENT	PO Number:		Invoice Number: 42762	Amount: 1,378.65
Description:		Invoice Date:	10/26/2020	Due Date:	11/26/2020
Sequence: 1	Check Type: Check	Checking Account ID: 5	Checking Account ID: 11967	Status: PP	1099 Amount: 0.00
<u>Chart of Account Number</u>	<u>Detail Description</u>	<u>Cost Center ID</u>	<u>Detail Amount</u>	<u>1099 Detail Amount</u>	<u>Asset/Asset Tag</u>
05 3200 490 000 4210 0 000	BELT REPLACED ON TREADMILL		1,378.65		In Full
				N	
Vendor ID: AMAZON	AMAZON	PO Number:		Invoice Number: 11132020	Amount: 66.73
Description:		Invoice Date:	10/29/2020	Due Date:	11/26/2020
Sequence: 1	Check Type: Check	Checking Account ID: 5	Checking Account ID: 11980	Status: PP	1099 Amount: 0.00
<u>Chart of Account Number</u>	<u>Detail Description</u>	<u>Cost Center ID</u>	<u>Detail Amount</u>	<u>1099 Detail Amount</u>	<u>Asset/Asset Tag</u>
05 3200 610 000 4010 0 000	CASH BOXES		58.74		In Full
05 3200 610 000 4120 0 000	INFLATABLE MICHOPHONE		7.99		In Full
				N	
Vendor ID: BMARIES	B. MARIE'S, LLC	PO Number:		Invoice Number: 2304	Amount: 60.00
Description:		Invoice Date:	11/03/2020	Due Date:	12/03/2020
Sequence: 1	Check Type: Check	Checking Account ID: 5	Checking Account ID: 11974	Status: PP	1099 Amount: 0.00
<u>Chart of Account Number</u>	<u>Detail Description</u>	<u>Cost Center ID</u>	<u>Detail Amount</u>	<u>1099 Detail Amount</u>	<u>Asset/Asset Tag</u>
05 3200 610 000 4230 0 000	SUSAN OTT'S FUNERAL		60.00		In Full
				N	
Vendor ID: BOBOLZCODY	BOBOLZ, CODY	PO Number:		Invoice Number: 111320	Amount: 74.22
Description:		Invoice Date:	09/30/2020	Due Date:	11/18/2020
Sequence: 1	Check Type: Check	Checking Account ID: 5	Checking Account ID: 11983	Status: PP	1099 Amount: 0.00
<u>Chart of Account Number</u>	<u>Detail Description</u>	<u>Cost Center ID</u>	<u>Detail Amount</u>	<u>1099 Detail Amount</u>	<u>Asset/Asset Tag</u>
05 3200 610 000 4060 0 000	FLOAT MATERIALS FOR HOMECOMING		74.22		In Full
				N	
Vendor ID: CENTRALVAL	CENTRAL VALLEY HIGH SCHOOL	PO Number:		Invoice Number: 111720	Amount: 50.00
Description:		Invoice Date:	11/11/2020	Due Date:	11/16/2020
Sequence: 1	Check Type: Check	Checking Account ID: 5	Checking Account ID: 11985	Status: PP	1099 Amount: 0.00
<u>Chart of Account Number</u>	<u>Detail Description</u>	<u>Cost Center ID</u>	<u>Detail Amount</u>	<u>1099 Detail Amount</u>	<u>Asset/Asset Tag</u>
05 3200 890 000 4320 0 000	UNIFIED BOWLING ENTRY FEE		50.00		In Full
				N	
Vendor ID: COLUMB	COLUMBUS PUBLIC SCHOOL	PO Number:		Invoice Number: 111120	Amount: 70.00
Description:		Invoice Date:	11/01/2020	Due Date:	11/11/2020
Sequence: 1	Check Type: Check	Checking Account ID: 5	Checking Account ID: 11978	Status: PP	1099 Amount: 70.00
<u>Chart of Account Number</u>	<u>Detail Description</u>	<u>Cost Center ID</u>	<u>Detail Amount</u>	<u>1099 Detail Amount</u>	<u>Asset/Asset Tag</u>
05 3200 890 000 4320 0 000	COLUMBUS HIGH BOWLING ENTRY FEE		70.00		In Full
				70.00 N	
Vendor ID: CUBBYS	CUBBYS	PO Number:		Invoice Number: 11132020	Amount: 546.24
Description:		Invoice Date:	10/01/2020	Due Date:	11/30/2020
Sequence: 1	Check Type: Check	Checking Account ID: 5	Checking Account ID: 11981	Status: PP	1099 Amount: 0.00
<u>Chart of Account Number</u>	<u>Detail Description</u>	<u>Cost Center ID</u>	<u>Detail Amount</u>	<u>1099 Detail Amount</u>	<u>Asset/Asset Tag</u>
05 3200 150 000 4011 0 000	GIFT CARDS CHAIN GANG		160.00		In Full
05 3200 610 000 4310 0 000	PIZZA FOR BOARD MEETING		48.12		In Full
05 3200 610 000 4270 0 000	SUPPLIES FOR BURGER BASH		338.12		In Full
				N	

Vendor ID: DAVIDC	DAVID CITY PUBLIC SCHOOL	PO Number:	Invoice Number: 110220	Amount:	1,298.21
Description:		Invoice Date: 11/01/2020	Due Date: 11/05/2020	Status: PP	1099 Amount: 0.00
Sequence: 1	Check Type: Check	Checking Account ID: 5	Check Number: 11966	Check Date: 11/02/2020	
<u>Chart of Account Number</u>	<u>Detail Description</u>	<u>Cost Center ID</u>	<u>Detail Amount</u>	<u>1099 Detail Amount</u>	<u>Asset/Asset Tag</u>
05 3200 890 000 4014 0 000	EXPENSES FOR 2020 SEASON		1,298.21	N	In Full
Vendor ID: DAVIDC	DAVID CITY PUBLIC SCHOOL	PO Number:	Invoice Number: 111120	Amount:	50.00
Description:		Invoice Date: 11/01/2020	Due Date: 11/13/2020	Status: PP	1099 Amount: 0.00
Sequence: 1	Check Type: Check	Checking Account ID: 5	Check Number: 11979	Check Date: 11/11/2020	
<u>Chart of Account Number</u>	<u>Detail Description</u>	<u>Cost Center ID</u>	<u>Detail Amount</u>	<u>1099 Detail Amount</u>	<u>Asset/Asset Tag</u>
05 3200 890 000 4017 0 000	DAVID CITY WRESTLING ENTRY FEE		50.00	N	In Full
Vendor ID: EASTBUTLER	EAST BUTLER PUBLIC SCHOOL	PO Number:	Invoice Number: 110220	Amount:	2,724.40
Description:		Invoice Date: 11/01/2020	Due Date: 11/05/2020	Status: PP	1099 Amount: 0.00
Sequence: 1	Check Type: Check	Checking Account ID: 5	Check Number: 11965	Check Date: 11/05/2020	
<u>Chart of Account Number</u>	<u>Detail Description</u>	<u>Cost Center ID</u>	<u>Detail Amount</u>	<u>1099 Detail Amount</u>	<u>Asset/Asset Tag</u>
05 3200 890 000 4014 0 000	EXPENSES FOR 2020 SEASON		2,724.40	N	In Full
Vendor ID: FOURSEASON	FOUR SEASONS FUND RAISING	PO Number:	Invoice Number: 111120	Amount:	1,897.00
Description:		Invoice Date: 11/01/2020	Due Date: 12/01/2020	Status: PP	1099 Amount: 0.00
Sequence: 1	Check Type: Check	Checking Account ID: 5	Check Number: 11976	Check Date: 11/11/2020	
<u>Chart of Account Number</u>	<u>Detail Description</u>	<u>Cost Center ID</u>	<u>Detail Amount</u>	<u>1099 Detail Amount</u>	<u>Asset/Asset Tag</u>
05 3200 610 000 4270 0 000	FRUIT SALES AND PIE SALES FUNDRAISING		1,897.00	N	In Full
Vendor ID: FREEMAN	FREEMAN HIGH SCHOOL	PO Number:	Invoice Number: 110420	Amount:	87.86
Description:		Invoice Date: 11/01/2020	Due Date: 11/05/2020	Status: PP	1099 Amount: 0.00
Sequence: 1	Check Type: Check	Checking Account ID: 5	Check Number: 11971	Check Date: 11/04/2020	
<u>Chart of Account Number</u>	<u>Detail Description</u>	<u>Cost Center ID</u>	<u>Detail Amount</u>	<u>1099 Detail Amount</u>	<u>Asset/Asset Tag</u>
05 3200 890 000 4012 0 000	BONUS FOR SUB-STATE		87.86	N	In Full
Vendor ID: HADLEY	HADLEY-BRAITHWAIT	PO Number:	Invoice Number: 221408, 221041	Amount:	357.45
Description:		Invoice Date: 11/02/2020	Due Date: 11/12/2020	Status: PP	1099 Amount: 0.00
Sequence: 1	Check Type: Check	Checking Account ID: 5	Check Number: 11975	Check Date: 11/11/2020	
<u>Chart of Account Number</u>	<u>Detail Description</u>	<u>Cost Center ID</u>	<u>Detail Amount</u>	<u>1099 Detail Amount</u>	<u>Asset/Asset Tag</u>
05 3200 610 000 4020 0 000	CANDY		357.45	N	In Full
Vendor ID: LUTHERAN	LUTHERAN HIGH NORTHEAST SCHOOLS	PO Number:	Invoice Number: 110420	Amount:	87.86
Description:		Invoice Date: 11/05/2020	Due Date: 11/05/2020	Status: PP	1099 Amount: 0.00
Sequence: 1	Check Type: Check	Checking Account ID: 5	Check Number: 11972	Check Date: 11/04/2020	
<u>Chart of Account Number</u>	<u>Detail Description</u>	<u>Cost Center ID</u>	<u>Detail Amount</u>	<u>1099 Detail Amount</u>	<u>Asset/Asset Tag</u>
05 3200 890 000 4012 0 000	BONUS FOR SUB-STATE		87.86	N	In Full
Vendor ID: NATLFFAORG	NATIONAL FFA ORGANIZATION	PO Number:	Invoice Number: MDS214003	Amount:	796.50
Description:		Invoice Date: 10/19/2020	Due Date: 11/19/2020	Status: PP	1099 Amount: 0.00

Invoice Listing - Detail

Sequence: 1	Check Type: Check	Checking Account ID: 5	Check Number: 11973	Check Date: 11/04/2020	
<u>Chart of Account Number</u>	<u>Detail Description</u>	<u>Cost Center ID</u>	<u>Detail Amount</u>	<u>1099 Detail Amount</u>	<u>Asset/Asset Tag</u>
05 3200 610 000 4270 0 000	FFA JACKETS		796.50	N	<u>In Full</u>
Vendor ID: NSAA	NE SCHOOL ACTIVITY ASSOCIATION	PO Number:	Invoice Number: 110420	Amount:	427.68
Description:		Invoice Date: 10/31/2020	Due Date: 11/04/2020	Status: PP	1099 Amount: 0.00
Sequence: 1	Check Type: Check	Checking Account ID: 5	Check Number: 11970	Check Date: 11/04/2020	
<u>Chart of Account Number</u>	<u>Detail Description</u>	<u>Cost Center ID</u>	<u>Detail Amount</u>	<u>1099 Detail Amount</u>	<u>Asset/Asset Tag</u>
05 3200 890 000 4012 0 000	HOSTING SUB-STATE		427.68	N	<u>In Full</u>
Vendor ID: NORFOLK	NORFOLK HIGH SCHOOL	PO Number:	Invoice Number: 111720	Amount:	25.00
Description:		Invoice Date: 11/11/2020	Due Date: 11/18/2020	Status: PP	1099 Amount: 0.00
Sequence: 1	Check Type: Check	Checking Account ID: 5	Check Number: 11984	Check Date: 11/17/2020	
<u>Chart of Account Number</u>	<u>Detail Description</u>	<u>Cost Center ID</u>	<u>Detail Amount</u>	<u>1099 Detail Amount</u>	<u>Asset/Asset Tag</u>
05 3200 890 000 4320 0 000	UNIFIED BOWLING ENTRY FEE		25.00	N	<u>In Full</u>
Vendor ID: OFFTHEWALL	OFF THE WALL GRAPHICS & PRINTING	PO Number:	Invoice Number: 111120	Amount:	481.50
Description:		Invoice Date: 10/01/2020	Due Date: 11/01/2020	Status: PP	1099 Amount: 0.00
Sequence: 1	Check Type: Check	Checking Account ID: 5	Check Number: 11977	Check Date: 11/11/2020	
<u>Chart of Account Number</u>	<u>Detail Description</u>	<u>Cost Center ID</u>	<u>Detail Amount</u>	<u>1099 Detail Amount</u>	<u>Asset/Asset Tag</u>
05 3200 610 000 4270 0 000	RISE AND GRIND T-SHIRTS		481.50	N	<u>In Full</u>
Vendor ID: PINNACLE	PINNACLE BANK	PO Number:	Invoice Number: 11132020	Amount:	152.91
Description:		Invoice Date: 11/01/2020	Due Date: 11/30/2020	Status: PP	1099 Amount: 0.00
Sequence: 1	Check Type: Check	Checking Account ID: 5	Check Number: 11982	Check Date: 11/13/2020	
<u>Chart of Account Number</u>	<u>Detail Description</u>	<u>Cost Center ID</u>	<u>Detail Amount</u>	<u>1099 Detail Amount</u>	<u>Asset/Asset Tag</u>
05 3200 610 000 4230 0 000	GET WELL ANGEL FOR HOEGERL		32.99	N	<u>In Full</u>
05 3200 610 000 4020 0 000	TORILLA CHIPS		79.92	N	
05 3200 150 000 4011 0 000	GIFT CARDS CHAIN GANG		40.00	N	
Vendor ID: STJOSE	ST. JOSEPH'S ATHLETIC CLUB	PO Number:	Invoice Number: 111720	Amount:	90.00
Description:		Invoice Date: 11/11/2020	Due Date: 11/13/2020	Status: PP	1099 Amount: 0.00
Sequence: 1	Check Type: Check	Checking Account ID: 5	Check Number: 11986	Check Date: 11/17/2020	
<u>Chart of Account Number</u>	<u>Detail Description</u>	<u>Cost Center ID</u>	<u>Detail Amount</u>	<u>1099 Detail Amount</u>	<u>Asset/Asset Tag</u>
05 3200 610 000 4010 0 000	BOOSTER CLUB AD IN CONFERENCE		90.00	N	<u>In Full</u>
Vendor ID: VALENTINO	VALENTINO'S	PO Number:	Invoice Number: 1718, 1692	Amount:	252.00
Description:		Invoice Date: 10/08/2020	Due Date: 11/08/2020	Status: PP	1099 Amount: 0.00
Sequence: 1	Check Type: Check	Checking Account ID: 5	Check Number: 11969	Check Date: 11/04/2020	
<u>Chart of Account Number</u>	<u>Detail Description</u>	<u>Cost Center ID</u>	<u>Detail Amount</u>	<u>1099 Detail Amount</u>	<u>Asset/Asset Tag</u>
05 3200 610 000 4020 0 000	PIZZA		252.00	N	<u>In Full</u>
Vendor ID: VOSSANDY	VOSS, SANDY	PO Number:	Invoice Number: 110420	Amount:	125.41
Description:		Invoice Date: 10/23/2020	Due Date: 11/18/2020	Status: PP	1099 Amount: 0.00

Invoice Listing - Detail

Sequence: 1 Check Type: Check Checking Account ID: 5 Check Number: 11968 Check Date: 11/04/2020
Chart of Account Number Detail Description Cost Center ID Detail Amount 1099 Detail Amount Asset/Asset Tag In Full
05 3200 610 000 4290 0 000 YADA SUPPLIES FOR RED RIBBON WEEK N 125.41

Vendor ID: WALMAR WAL-MART PO Number: 112420 Invoice Number: 112420 Amount: 201.30

Description: Invoice Date: 10/23/2020 Due Date: 11/30/2020 Status: PP 1099 Amount: 0.00
Sequence: 1 Check Type: Check Checking Account ID: 5 Check Number: 11987 Check Date: 11/24/2020
Chart of Account Number Detail Description Cost Center ID Detail Amount 1099 Detail Amount Asset/Asset Tag In Full
05 3200 610 000 4190 0 000 SUPPLIES FOR ONE ACT N 173.62
05 3200 610 000 4020 0 000 GATORADE N 27.68

Batch 1099 Total: 70.00 Batch Total: 11,300.92

Report 1099 Total: 70.00 Report Total: 11,300.92

Activities Director Report: December

1. One-Act finished 6th at districts
2. Unified Bowling Finished District Runner Up
3. NSAA Academic All-State for Fall Sports
 - a. Football - Grant Brigham and Colin Wingard
 - b. Softball - Kira Pavlik
 - c. One Act - Hunter White and Emily Augustin
 - d. Volleyball - Maddie Hopwood and Emily Willis
 - e. Unified Bowling - Grady Belt and Tanner Nekl
4. Holiday Tournament @ SRC Dec. 28-29
 - a. Day 1 SRC will play at 12:00 and 3:30
5. Speech has 25 students participating
6. Looking at senior night for winter sports in early January.

Shelby-Rising City School Board
Elementary Principal's Report
Board Meeting 12-14-2020

Current Enrollment: Preschool 3 - 10 (1 additional student registered to begin 1-5-21);
Preschool 4- 16 (1 additional student registered to begin 1-5-21); K - 27; First - 33; Second - 27;
Third - 26; Fourth - 29; Fifth - 21

Olivia Bell (daughter to Justin "Shorty" Bell) has been filling in for Ms. Doehling during her winter break from UNL. She is studying to be a SLP. Mrs. Willis reports she is doing a great job in the Title I room and she appreciates having someone assisting students (even if it is just until January 11th.) Additionally, Isabel Small has been helping out in the elementary. She is a junior at Dakota State and is working with our students who were in quarantine to get them caught up and offer repeated practices.

Book-It Assembly on Friday, December 4th: October PBiS Students of the Month: Kyra W., Arika H., Danika K. and November PBiS Students of the Month: Cole H., Esmerelda C., and Jackson H.

Nebraska State Principals Conference was held virtually on Thursday, December 10th. Perry Law presented a very informative Title IX session, representatives from Compassion Resiliency shared ideas regarding how to keep yourself, your teachers, and your students "sane" and calm during this time. KSB Law presented on how Covid-19 affects special education, Title IX, FCCRA, LB881, etc. programs and what is acceptable and not.

MAP testing will take place on Monday, December 14 and Tuesday, December 15 in the elementary. All students K-5 will participate. Acadience (formerly DIBELS) fluency testing will take place after we return from winter break.

Elementary Winter Programs will be video recorded on Monday, December 21st from 1:30-3:30.

Research is currently taking place for the possibility of starting a Summer Jump Start program to help those students who are still behind following our Remote Learning from last year and quarantining from this year, catch up. Discussions have taken place with Districts who are our size of smaller to learn more about how these programs are scheduled. Humphrey and Cedar Bluff are two local Districts who received grants for extended learning from NDE.

December 9th Remote Learning numbers: Two second grade students at the elementary came to school to receive 1:1 assistance in getting caught up after an extended quarantine. Title I worked virtually with 2 students, 4th grade Zoomed with 86% of the class, 1st grade Zoomed with 6% of their students who had been on extended quarantines; third grade met through Zoom with 72% of their class, and fifth grade Zoomed with 64% of their students. 3-5 provided review and the opportunity for students to ask questions and seek clarification on lessons. Resource met virtually with their students to keep up with IEP hours.

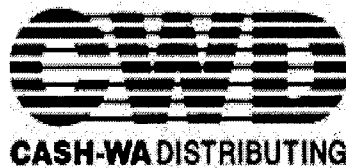

To:
 Shelby Public School
 Brenda Gates
 650 N. Walnut Street
 Shelby, NE 68662
 402-527-5946 (Contact)

Project:
 Shelby Public School

From:
 Cash-Wa Distributing Co.
 Randy Kratochvil
 401 West 4th Street
 Kearney, NE 68848
 800-652-0010 EXT. 7241
 FAX (308) 234-4372

Customer 200910

Job Reference Number: 8358

Item	Qty	Description	Sell	Sell Total
<u>2</u>	1 ea	DISHWASHER, DOOR TYPE Hobart Model No. AM15T-2 Dishwasher, door type, Tall Chamber, hot water/chemical sanitizing, 58-65 racks/hour, straight-thru or corner, solid-state controls with digital status, with booster heater, electric tank heat, PRV included, auto-fill, stainless steel tank, frame, doors & feet, 208-240/60/3, sheet pan rack, ENERGY STAR®	\$14,990.00	\$14,990.00
	1 ea	Standard warranty - 1-Year parts, labor & travel time during normal working hours within the USA		
	2 ea	RACK-6PAN 6 pan rack to hold sheet pans (Tall only)	\$250.00	\$500.00
	1 ea	AM15-2 Installation of new Hobart AM15-2 Dishwasher and Removal of old Dishmachine.	\$1,310.00	\$1,310.00
Delivered Price.				
Sales Tax to be added at the time of invoicing if applicable.				
Uncrating and Installation and start up of new Machine, and removal of Old Machine by Hobart of Grand Island.				
			ITEM TOTAL:	\$16,800.00
			Merchandise	\$16,800.00
			Total	\$16,800.00

****Prices guaranteed for 30 Days, Special Order items CANNOT be returned****

All material is guaranteed to be specified and the above work to be performed in accordance with the drawings and specifications submitted for above work and completed in a substantial workmanlike manner for the sum of Dollars(\$).

Deposit: A 30%-50% down payment will be required BEFORE orders will be placed and is dependent upon account terms.

30% _____
 50% _____

Direct Ship Items: Please note it is the responsibility of the customer to file all freight claims directly with the freight company. CWD will not file any direct shipment claims with the freight companies on direct shipments. *Please check all items thoroughly at time of delivery and address any issues with the carrier at the time of delivery.* We strongly suggest that on direct shipments, boxes are opened and inspected thoroughly at time of delivery **BEFORE SHIPMENTS ARE RECEIVED**, before transporter leaves the job site as concealed damage also needs to be reported directly to shipper, **IMMEDIATELY**. All freight companies have a window of time to report concealed damage otherwise they are not responsible and neither is CWD.

ITEM 300135-A REPORTING CONCEALED DAMAGE

(a) When damage to, or loss of, contents of a shipping container is discovered by the consignee that could not have been determined at time of delivery it must be reported by the consignee to the delivering carrier upon discovery. (b) Reports must include a request for inspection by the carrier's representative. (c) Notice of loss or damage and request for inspection may be given by telephone or in person, but in either event must be confirmed by a written or electronic communication. (d) While awaiting inspection by carrier, the consignee must hold the shipping container and its contents in the same condition they were in when damage was discovered, insofar as it is possible to do so. (e) **Unless otherwise specified by the carrier, notice of loss or damage should be provided to the carrier within five (5) business days from the date of delivery.** (f) If five (5) business days, or such other period as specified by the carrier, pass between the date of delivery of the shipment by carrier and date of report of loss or damage and request for inspection by consignee, it is incumbent upon the consignee to offer reasonable evidence to the carrier's representative when inspection is made that loss or damage was not incurred by the consignee after delivery of shipment by carrier.

SUPPLEMENT 1 TO NMF 100-AO PROCEDURES GOVERNING THE INVESTIGATION AND DISPOSITION OF FREIGHT CLAIMS FOR LOSS OR DAMAGE

Only participants in the NMFC® at the time the transportation occurs may use the provisions herein. 14 For explanation of abbreviations and reference marks, see last page of this Supplement. ©NMFTA 2015 ITEM 300135-A-Continued (g) Reasonable evidence includes, but is not limited to: 1. Identifying the party(ies) responsible for unloading, 2. Identifying the chain of custody of the article, including prior transportation by any mode, 3. Location(s) of the article(s) once the shipment was received until the damage was noted, 4. Any mechanical or physical handling by the consignee subsequent to delivery by the carrier. (h) If a clear delivery receipt is available on the shipment, e.g. no damage or shortage is noted, the claimant must provide documentation showing that damage or loss occurred prior to delivery

CWD Distributing payment terms for all special or custom order equipment is 7 days from date of invoice dependent upon agreed to terms. CWD may file a UCC1 form with the state on all equipment purchased over \$1000.00. If this is a Proposal for an Exhaust System, the customer must meet all NFPA 96 Exhaust Hood Codes &/or Local & State Codes approved by Local Fire Marshall. If not all Codes are met CWD cannot and will not install any of the food service equipment that is to be located under this exhaust system. Any alterations or deviation from above specifications involving extra costs will be executed upon written orders and will become an extra charge over and above the estimate. All agreements are contingent upon strikes, accidents or delays beyond our control. Owners to carry fire, tornado, and other necessary insurance upon above work. Workman's compensation and public liability insurance on above work to be taken out by:

Respectfully Submitted _____
Cash-Wa Distributing

ACCEPTANCE OF PROPOSAL- the above prices, specifications and conditions are satisfactory and are hereby accepted. You are authorized to do the work as specified. Payment will be made as outlined. Remainder payment due within terms upon delivery.

Company: _____

Date: _____

Signature: _____

Thanks,
Randy Kratochvil
Equipment Sales Specialist
WEB LINK: www.cashwa.com/services/equipment
CashWa Distributing Company
Phone: 800-652-0010 Ext 7241
Fax: 308-234-4372
randy.kratochvil@cashwa.com

Acceptance: _____ Date: _____

Printed Name: _____

Project Grand Total: \$16,800.00



Project _____
 AIA # _____ SIS # _____
 Item # _____ Quantity _____ C.S.I. Section 114000

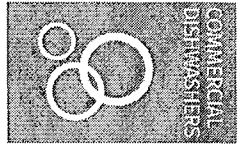

AM15 TALL ELECTRIC High Temperature Door-Style Dishwashing Machine

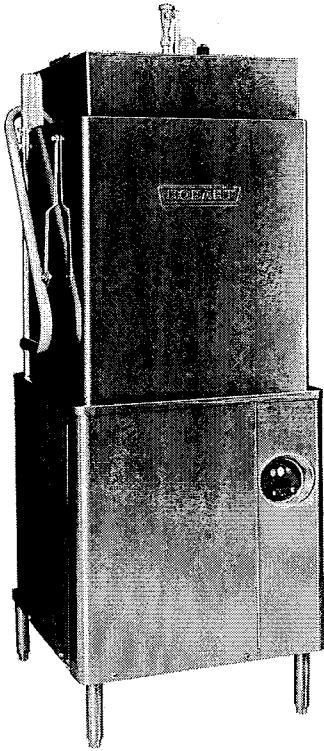

SPECIFIER STATEMENT

Specified unit will be Hobart model AM15T high temperature door-type dishwashing machine. Features extended 27" door opening, auto-start, digital controls, NSF pot & pan listing, one piece scrap screen and basket system, interchangeable stainless steel wash and rinse arms, rinse 58 racks per hour, .74 U.S. gallons per rack.

1 year parts and labor warranty.

STANDARD FEATURES

- + .74 gallons per rack final rinse water
- + 58 racks per hour – hot water sanitizing
- + NSF pot and pan listed for 2-, 4- & 6-minute cycles
- + Timed wash cycles for 1, 2, 4 or 6 minutes
- + 27" door opening for 18" x 26" sheet pans or 60 quart mixing bowl
- + Solid state, integrated controls with digital status indicators
- + Self-draining, high efficiency stainless steel pump and stainless steel impeller
- + Stainless steel drawn tank, tank shelf, chamber, trim panels, frame and feet
- + Spring counterbalanced chamber with polyethylene guides
- + Revolving, interchangeable upper and lower anticlogging wash arms
- + Revolving, interchangeable upper and lower rinse arms
- + Slanted, self-locating, one-piece scrap screen and basket system
- + Automatic fill
- + Door actuated start
- + Automatic drain closure
- + Vent fan control
- + External booster activation
- + Delime cycle
- + Service diagnostics
- + Straight-through or corner installation
- + Hot water sanitation
- + End of cycle audible alarm (field activated)
- + Delime notification (field activated)
- + 3/4" pressure regulator valve

OPTIONS & ACCESSORIES (Available at extra cost)

- Sense-A-Temp™ 70°F rise electric booster heater
- Single point electric kit (field or factory installed) for booster equipped machines (3ph only)
- Peg rack
- Combination rack
- Splash panel kit (for corner installations)
- Flanged and seismic feet
- Front loading kit (field installation required)
- Drain water tempering kit
- Water hammer arrestor kit

AM SELECT SERIES – AM15 TALL ELECTRIC

Approved by _____ Date _____ Approved by _____ Date _____



AM15 TALL ELECTRIC High Temperature Door-Style Dishwashing Machine

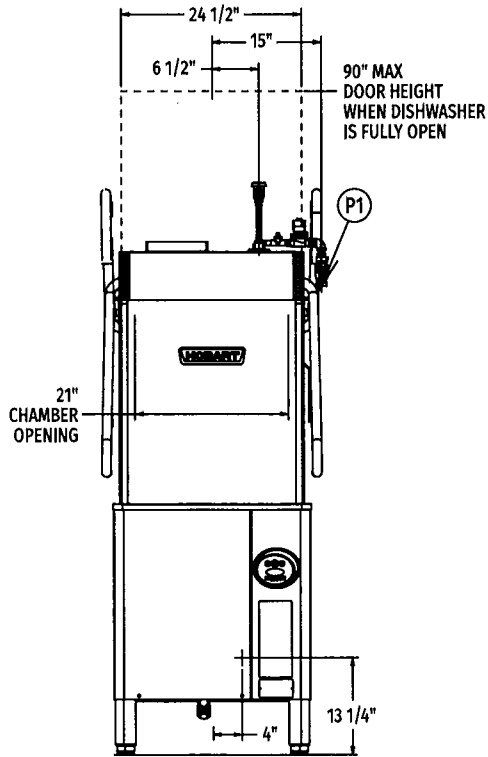

Front View

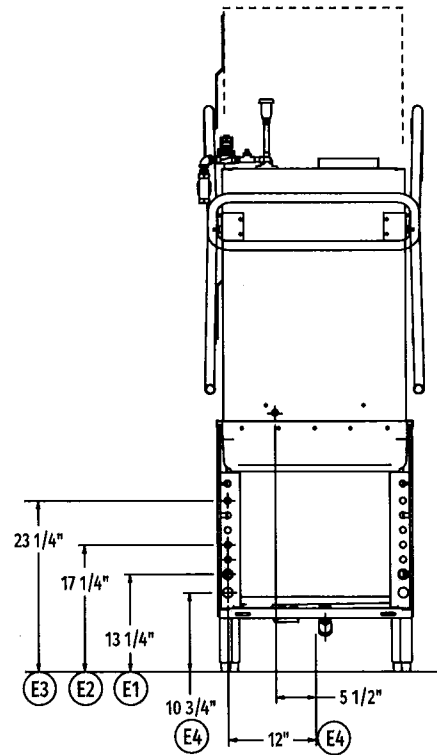

Rear View

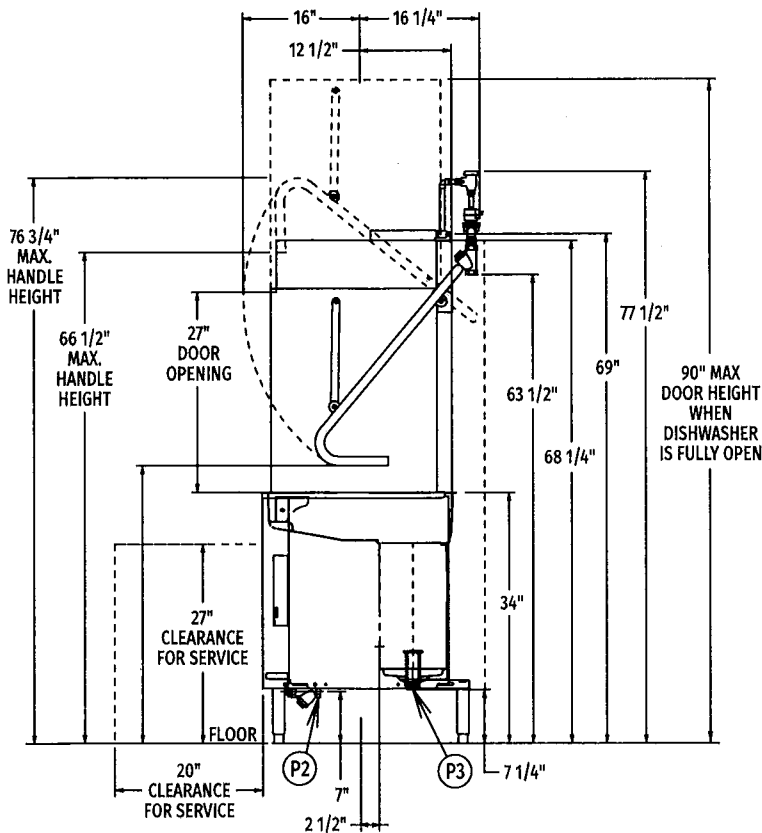

Right Side View

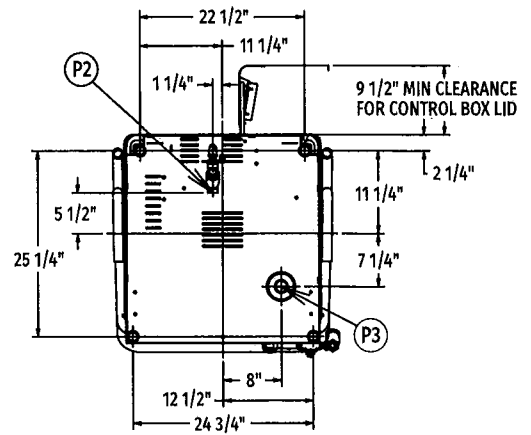

Bottom View

MODEL:
AM15T
E-893960
REV F



AM15 TALL ELECTRIC

High Temperature Door-Style Dishwashing Machine

LEGEND

Electrical Connections	
E1	Electric tank heat, motors & controls: 3/4" or 1" conduit, 13-1/4" AFF.
E2	External booster control (optional). 1/2" conduit hole. (Booster 1 & booster 2) 0.1 amps @120 FAC, 15-1/4" AFF.
E3	Internal electric booster heater (optional): 1" conduit, 10-3/4" AFF.
E4	Vent fan control. 1/2" conduit hole. (VFC1 & VFC2) 1.5 amps @ nameplate supply voltage, "ON", 17-1/4" AFF.
NOTE: Optional single point connection (when selected) can utilize either E1/E2 conduit.	
Plumbing Connections	
P1	Common water connection (for use without internal booster heater): 180°F minimum incoming water, 3/4" FTP, 52-1/2" AFF.
P2	Common water connection (for use with internal booster heater): 110°F minimum incoming water, 3/4" FTP, 7" AFF.
P3	Drain connection: 1-1/2 NPT, 7-1/4" AFF.
NOTE: Cold water connection at P3 (as needed) when optional drain water tempering kit is included: 55-80°F recommended water, 1/2" MPT, 7" AFF.	

WARNING: Plumbing and electrical connections should be made by qualified personnel who will observe all the applicable plumbing, sanitary, safety codes and National Electrical Code.

E1 AM15 with Electric Tank Heat, Motors and Controls			
Voltage	Rated Amps	Minimum Supply Circuit Ampacity	Maximum Protective Device
208-240/60/1	43.0	50	50
208-240/60/3	24.6	30	30
480/60/3	11.6	15	15

E2 Booster Heat 8.5kW, Minimum 110°F Incoming Water			
Voltage	Rated Amps	Minimum Supply Circuit Ampacity	Maximum Protective Device
208-240/60/1	35.4	50	50
208-240/60/3	20.4	30	30
480/60/3	10.2	15	15

SPECIFICATIONS

Capacities

Racks Per Hour (maximum).....	58
Wash Tank (U.S. gallons).....	14

Motor Horsepower

Wash	2
------------	---

Water Consumption

Wash Pump (gallons per minute – Weir Test).....	160
---	-----

Rinse

Minutes Operated during Hour of Capacity Operation	9.66
Seconds of Rinse per Rack	10
Rate of Rinse Flow (gallons per minute at 20 lbs. flow pressure).....	4.4
Rinse Cycle (gallons per rack at 20 PSI flow)	74-180°F Min.

Peak Rate of Drain Flow

Gallons per Minute (initial rate with full tank).....	14
---	----

Heating

Electric Tank Heating Unit (kW).....	5
Electric Booster Heater (kW) (optional).....	8.5

Exhaust Requirements

.....	450
-------	-----

Shipping Weight (approximate).

.....	354 lbs. (without booster)
.....	384 lbs. (with booster)

Crated Dimensions.

.....	41.5"L x 35.5"W x 68"H
-------	------------------------

Common Electrical Connection (Single Point) Service Includes Tank Heat, Motors, Controls and Internal Booster Heater			
Voltage	Rated Amps	Minimum Supply Circuit Ampacity	Maximum Protective Device
208-240/60/3	45.4	60	60
480/60/3	23.7	30	30
*200-240/50/3	45.4	60	60
*380-415/50/3	25.2	30	30
NOTE: Only available in 3ph machines, field or factory installed options.			

Plumbing Notes: Water hammer arrestor (meeting ASSE-1010 standard or equivalent) in common water supply line at service connection.

Recommended water hardness to be 3 grains or less for best results.

Recommended building flowing water pressure to the dishwasher is 15-25 PSI. If pressures higher than 25 PSI are present, a pressure regulating valve with internal thermal expansion bypass must be supplied (by others) in the water line to the dishwasher.

For convenience when cleaning, water tap should be installed near machine with heavy duty hose and squeeze valve.



AM15 TALL ELECTRIC High Temperature Door-Style Dishwashing Machine

AM15 TABLING CONFIGURATIONS AND TRACK DESIGN

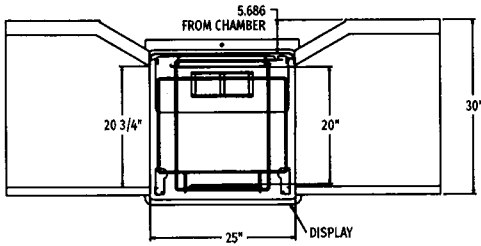

Pass Thru Installation

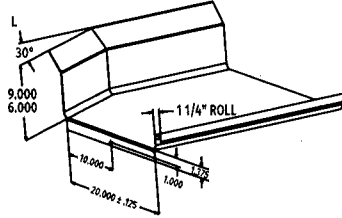

Suggested Track Design

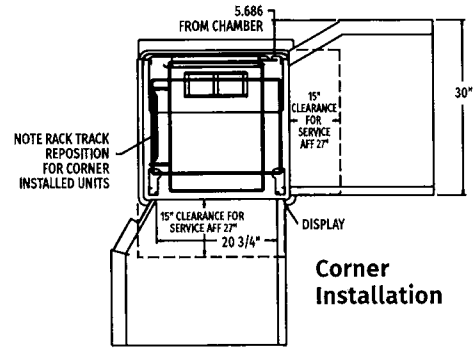

Top Inside View of Machine

As continued product improvement is a policy of Hobart, specifications are subject to change without notice.