

Madison Board of Education, Madison District #1

Board of Education Regular Meeting
Monday, August 10, 2020 7:00 PM
Middle School/High School Conference Room
700 South Kent St.
Madison, NE 68748-0450

The sequence of items on the agenda is provided as a courtesy. The board reserves the right to consider items in any sequence deemed appropriate. Therefore, visitors are encouraged to attend the meeting from the beginning.

1. Call the Meeting to Order
 1. Roll Call
 2. Pledge of Allegiance
 3. Open Meetings Act
 4. Madison Public Schools Mission Statement
2. Consent Agenda
3. Public Forum
4. Administrator and Other Reports
5. Board Committee Reports/Meeting dates
6. Action Items
 1. Discuss, consider, and take all necessary action to reaffirm Board policies 1001-1003
 2. Discuss, consider, and take all necessary action to approve resignation.
 3. Discuss, consider, and take all necessary action on contracts.
 4. Discuss the 2019-20 budget needs of Madison Public Schools along with feedback on building the budget if the district valuation decreases over two percent.
 5. Discuss, consider, and take all necessary action to purchase Middle School Student ipads with Grant funds.
 6. Discuss, consider, and take all necessary action on the purchase of technology items using CARE grant funds for Trinity and St. Leonards schools.
7. Discuss, consider, and take all necessary action to approve board policies 3057 Title IX and 2006 Complaint procedure policies.
8. Discuss, consider, and take all necessary action to purchase an auto scrubber to complete floor care.
9. Topics for next month's Board of Education meeting
10. Adjournment

The board reserves the right to enter executive session if it deems it necessary to prevent needless injury to a staff member's reputation or for the protection of the public interest.

Kate Ebeling: Present, Harlow Hanson: Present, Jim Knapp: Present, Deb Neidig, Present, Jim Reeves: Present, Steve Ruh: Present. Present: 6

1: Call the meeting to order

Motion to call the meeting to order at 7:05 pm. Passed with a motion by Kate Ebeling and a second by Jim Knapp. Kate Ebeling: Yea, Harlow Hanson: Yea, Jim Knapp: Yea, Deb Neidig: Yea, Jim Reeves: Yea, Steve Ruh: Yea. Yea: 6, Nay: 0

- 1.1 Roll Call
- 1.2 Pledge of Allegiance
- 1.3 Open Meetings Act
- 1.4 Madison Public Schools Mission Statement

2: Consent Agenda

Motion to approve consent agenda items 2.1, 2.2 & 2.3 as presented. Passed with a motion by Jim Reeves and a second by Deb Neidig. Kate Ebeling: Yea, Harlow Hanson: Yea, Jim Knapp: Yea, Deb Neidig: Yea, Jim Reeves: Yea, Steve Ruh: Yea. Yea: 6, Nay: 0

Albracht Disposal Service	Waste Disposal	325.00
Amazon.Com Credit	Supplies	1,769.55
Apple Computer, Inc.	Supplies	11,490.00
Assetgenie, Inc. DBA Agirepair	Computer Repair	243.00
Automated Dairy Specialists, LLC	Supplies	975.00
BCN	Phone Service	93.70
Brady & Amy's	Fuel	10.50
BSN Sports, LLC	Supplies	38.03
Centerpoint Energy Services, Inc.	Natural Gas	5,924.70
Central Nebraska Rehab Services	Services	1,386.00
Choice Foods	Fuel/Supplies	160.46
City of Madison	Utilities	8,275.06
Colonial Research Chemical	Supplies	676.20
Computers Etc	Supplies	79.42
Daberkow-Wagner Builders, Inc.	Maintenance	6,458.00
Dent Specialists	Repairs	1,311.76
Depew, Kimberly	Coaches Camp	600.00
DHSDPH Health Licensing	License Renewal	50.00
Douglas, Timothy	Reimbursement	14.50
Duerst, Brandon	Lawn Service	3,500.00
Eakes Office Solutions	Supplies	696.00
Ecolab Pest Elimination Division	Pest control	81.85
Educational Service Unit #8	License Renewal/Services	48,805.74
Egan Supply Co.	Supplies	1,253.19
Eisenmann Supplies	Supplies	86.78
Field's Hardware	Supplies	148.64
Floor Maintenance	Supplies	33.18
Frontier	Phone Service	692.75
Greatamerica Financial Services Corporation	Copier Lease	758.14
Heartland Communications	Maintenance	975.00
Hermitage Art Company, Inc.	Supplies	39.22
Houghton Mifflin Co	Supplies	2,284.20
Innovative Office Solutions, LLC	Supplies	4,663.82
International Academy of Science, Acellus	Supplies	8,000.00

IXL Learning	Teaching Supplies	539.00
Jackson Services	Supplies	97.15
JAMF Software, LLC	Tech Subscription	5,500.00
KSB School Law	Legal Services	603.00
Madison Star Mail	Publications/Supplies	842.65
MARC (Mid-American Research Chemical)	Supplies	30.00
Menards-Norfolk	Supplies	417.94
Midwest Technology Products	Supplies	73.68
MPS Activity Fund	Transfer	30,000.00
MPS Lunch Fund	Transfer	30,000.00
MPS Petty Cash	Reimbursement	107.68
NE Regional Deaf Ed Program	Services	638.40
Nebraska Council of School Administrator	Registration	150.00
Nebraska ESU Coordinating Council	License	330.00
Nebraska Public Health Environmental Lab	Water Testing	46.00
Northeast Nebraska Juvenile Services	Reimbursement	7,703.37
Nykodym Lawn Service	Lawn Service	1,250.00
O'Keefe Elevator Co., Inc.	Elevator Maintenance	311.84
Otis Elevator Company	Elevator Contract	727.20
Parco Scientific Company	Supplies	9.50
Pfeifer, Janet	Reimbursement	152.58
Pitney Bowes	Postage	1,117.00
Priority Communications & Solutions Inc.	Repairs	113.00
Quill Corporation	Supplies	307.05
Rapids Wholesale	Supplies	14.46
Real Reptiles	Presentation	250.00
Reigle Implement Co., Inc.	Supplies/Maintenance	548.80
RS Electric	Maintenance	1,110.58
S&S Worldwide	Supplies	70.57
Scheer's Ace Hardware	Supplies	133.95
School Health Corporation	Supplies	70.08
School Specialty Supplies	Supplies	274.59
Sherwin Williams Co	Supplies	94.76
Short Stop, The	Fuel	103.68
Software Unlimited, Inc.	Software Renewal	6,850.00
Sparklight (Formerly Cable One)	Cable Box Rental	27.02
Troxell Communications	Supplies	23.48
Uline	Supplies	809.70
US Bank Cardmember Services	Supplies	1,625.45
Virco Mfg Corporation	Supplies	718.20
Volkman Plumbing & Heating	Maintenance/Repairs	925.00
Voyager Sopris Learning	Supplies	1,089.11
Walmart Community	Supplies	253.51
Water Engineering Inc.	Water Service	425.04
Winsupply Norfolk NE Co	Supplies	283.74

3: Public forum

4: Administrator and other reports

5: Board Committee Reports/Meeting dates

6: Action Items

7: Discuss, consider and take all necessary action on yearly rental agreement with the City of Madison for use of the auditorium at the rate of \$2,500.00

Motion to approve the rental agreement with the City of Madison for use of the auditorium in the amount of \$2,500.00. Passed with a motion by Steve Ruh and a second by Deb Neidig. Kate Ebeling: Yea, Harlow Hanson: Yea, Jim Knapp: Yea, Deb Neidig: Yea, Jim Reeves: Yea, Steve Ruh: Yea. Yea: 6, Nay: 0

8: Discuss, consider and take all necessary action on a Return to Learning Plan for 2020-2021.

Motion to accept a Return to Learning Plan resolution for the 2020-2021 school year with suggested changes. Passed with a motion by Kate Ebeling and a second by Jim Knapp. Kate Ebeling: Yea, Harlow Hanson: Yea, Jim Knapp: Yea, Deb Neidig: Yea, Jim Reeves: Yea, Steve Ruh: Yea. Yea: 6, Nay: 0

9: Discuss, consider, and take all necessary action on fleet inspections.

Motion to accept a bid from Big Country Ford for fleet inspections. Passed with a motion by Jim Reeves and a second by Deb Neidig. Kate Ebeling: Yea, Harlow Hanson: Yea, Jim Knapp: Yea, Deb Neidig: Yea, Jim Reeves: Yea, Steve Ruh: Yea. Yea: 6, Nay: 0

10: Discuss, consider, and take all necessary action on annual transfers of \$30,000 each to the activities and lunch funds.

Motion to transfer \$30,000 each to the activity and lunch funds. Passed with a motion by Steve Ruh and a second by Jim Knapp. Kate Ebeling: Yea, Harlow Hanson: Yea, Jim Knapp: Yea, Deb Neidig: Yea, Jim Reeves: Yea, Steve Ruh: Yea. Yea: 6, Nay: 0

11: Discuss, consider, and take all necessary action on membership to Nebraska Rural Community Schools Association (NRCSA).

Motion to join membership in the NRCSA for the 2020-2021 school year. Passed with a motion by Deb Neidig and a second by Jim Reeves. Kate Ebeling: Yea, Harlow Hanson: Yea, Jim Knapp: Yea, Deb Neidig: Yea, Jim Reeves: Yea, Steve Ruh: Yea. Yea: 6, Nay: 0

12: Discuss, consider, and take all necessary action on the topic of extra duty staffing if school closure is required during the 2020-2021 school year.

13: Discuss, consider, and take all necessary action on the topic of classified staff salaries and benefits if school closure is required during the 2020-2021 school year.

14: Discuss, consider, and take all necessary action on the 2020-2021 softball season.

Motion to cancel the 2020-2021 softball season due to lack of players to field a team. Passed with a motion by Deb Neidig and a second by Kate Ebeling. Kate Ebeling: Yea, Harlow Hanson: Yea, Jim Knapp: Yea, Deb Neidig: Yea, Jim Reeves: Yea, Steve Ruh: Yea. Yea: 6, Nay: 0

15: Discuss, consider, and take all necessary action to approve a change order to use sod vs hydro-seeding on the west side of the middle school commons.

Motion to approve a change order to use sod in place of hydro-seeding on the west side of the middle school commons. Passed with a motion by Deb Neidig and a second by Jim Knapp. Kate Ebeling: Yea, Harlow Hanson: Yea, Jim Knapp: Yea, Deb Neidig: Yea, Jim Reeves: Yea, Steve Ruh: Yea. Yea: 6, Nay: 0

16: Topics for next month's Board of Education meeting.

17: Adjournment

Motion to adjourn at 8:22 PM. Passed with a motion by Deb Neidig and a second by Harlow Hanson. Kate Ebeling: Yea, Harlow Hanson: Yea, Jim Knapp: Yea, Deb Neidig: Yea, Jim Reeves: Yea, Steve Ruh: Yea. Yea: 6, Nay: 0

President

Secretary

Kate Ebeling: Absent, Harlow Hanson: Present, Jim Knapp: Present, Deb Neidig, Present, Jim Reeves: Present, Steve Ruh: Present. Present: 5, Absent: 1

1: Call the Hearing to order

Motion to call the meeting to order at 6:45 pm. Passed with a motion by Harlow Hanson and a second by Jim Knapp. Harlow Hanson: Yea, Jim Knapp: Yea, Deb Neidig: Yea, Jim Reeves: Yea, Steve Ruh: Yea. Yea: 5, Nay: 0 Absent: 1

1.1 Roll Call

1.1.1 Excuse absent board members

1.2 Open Meetings Act

2: Special Hearing to review and receive feedback on Board Policies 5018 & 5045.

3: Adjourn the Hearing

Motion to adjourn Hearing at 7:04 PM. Passed with a motion by Jim Reeves and a second by Jim Knapp. Harlow Hanson: Yea, Jim Knapp: Yea, Deb Neidig: Yea, Jim Reeves: Yea, Steve Ruh: Yea. Yea: 5, Nay: 0 Absent: 1

President

Secretary

Kate Ebeling: Present, Harlow Hanson: Present, Jim Knapp: Present, Deb Neidig, Present, Jim Reeves: Present, Steve Ruh: Present. Present: 6

Motion to call the meeting to order at 8:30 am. Passed with a motion by Kate Ebeling and a second by Jim Knapp. Kate Ebeling: Yea, Harlow Hanson: Yea, Jim Knapp: Yea, Deb Neidig: Yea, Jim Reeves: Yea, Steve Ruh: Yea. Yea: 6, Nay: 0

- 1.1 Roll Call
- 1.2 Pledge of Allegiance
- 1.3 Open Meetings Act
- 1.4 Madison Public Schools Mission Statement

2: Consent Agenda

Motion made to accept the agenda as the official agenda. Passed with a motion by Deb Neidig and a second by Jim Knapp. Kate Ebeling: Yea, Harlow Hanson: Yea, Jim Knapp: Yea, Deb Neidig: Yea, Jim Reeves: Yea, Steve Ruh: Yea. Yea: 6, Nay: 0

3: Board work session (discussion items)

- 3.1 State of the School presentation 8:35-9:00 am
- 3.2 Review of Board goals 9:00-9:15 am
- 3.3 Review of Superintendent goals 9:15-9:30 am
- 3.4 Presentation on the 2020-2021 Budget factors 9:30-9:45 am
- 3.5 Discussion on level of support from ESU #8 and options to explore in regards to migrant education & EL 9:45-9:50 am
- 3.6 Break 9:50-10:00 am
- 3.7 July 16th Prom overview and July 18th Graduation overview (Mr. Crilly) 10:00-10:15 am
- 3.8 Middle school grant overview (Mr. Ehrisman) 10:15-10:30 am
- 3.9 Little Dragon Child Care and Family Literacy grant (Mrs. Kush) 10:30-10:45 am
- 3.10 Philosophy of use for the new gym (Mr. Mackey) 10:45-11:00 am
- 3.11 Next steps for Marzano Common Language of Learning (Mrs. Ernst) 11:00-11:15 am
- 3.12 Working lunch 11:15-11:45 am
- 3.13 Starting school in the fall contingency plans 11:30-12:00 pm
- 3.14 Transportation plan (Mr. Ehlers) 12:00-12:05 pm
- 3.15 Breakfast and lunch program plan (Mr. Ehlers) 12:05-12:10 pm
- 3.16 Building level PPE procedures (building Principals) 12:10-12:15 pm

4. Adjourn the Meeting

Motion to adjourn meeting at 12:19 PM. Passed with a motion by Kate Ebeling and a second by Jim Reeves. Kate Ebeling: Yea, Harlow Hanson: Yea, Jim Knapp: Yea, Deb Neidig: Yea, Jim Reeves: Yea, Steve Ruh: Yea. Yea: 6, Nay: 0

President

Secretary

<u>Vendor Name</u>	<u>Invoice</u>	<u>Description</u>	<u>Amount</u>
Checking	1		
Checking	1	Fund: 01 GENERAL FUND	
ACCO BRANDS USA LLC	4713096087	SUPPLIES	4.22
ACCO BRANDS USA LLC	4713427968	SUPPLIES	74.40
		Vendor Total:	78.62
ALBRACHT DISPOSAL SERVICE	16482	DISPOSAL	155.00
ALBRACHT DISPOSAL SERVICE	16483	DISPOSAL	170.00
		Vendor Total:	325.00
ALPHA WORKFORCE HEALTH	11712	DOT PHYSICAL	80.00
		Vendor Total:	80.00
AMAZON.COM CREDIT	433568965976	SUPPLIES	1,322.50
AMAZON.COM CREDIT	4446956339775	SUPPLIES	35.79
AMAZON.COM CREDIT	447979969934	SUPPLIES	59.41
AMAZON.COM CREDIT	453989585465	SUPPLIES	26.99
AMAZON.COM CREDIT	4574738543338	SUPPLIES	104.37
AMAZON.COM CREDIT	466657445379	SUPPLIES	(1,322.50)
AMAZON.COM CREDIT	673796995666	SUPPLIES	315.28
AMAZON.COM CREDIT	749535746453	SUPPLIES	708.45
AMAZON.COM CREDIT	877334438733	SUPPLIES	1,322.50
AMAZON.COM CREDIT	884888978478	SUPPLIES	45.84
		Vendor Total:	2,618.63
APPLE COMPUTER, INC.	20200805	SUPPLIES	6,995.00
		Vendor Total:	6,995.00
APPLE, INC	AC3179277	COMPUTER REPAIRS	99.00
		Vendor Total:	99.00
ASSETGENIE, INC DBA AGIREPAIR	1483223	COMPUTER REPAIRS	100.00
ASSETGENIE, INC DBA AGIREPAIR	1483418	COMPUTER REPAIRS	100.00
ASSETGENIE, INC DBA AGIREPAIR	1485905	COMPUTER REPAIRS	150.00
		Vendor Total:	350.00
BCN	22948652	PHONE SERVICE	105.35
		Vendor Total:	105.35
BIG COUNTRY AUTO	69033	INSPECTION	146.56
BIG COUNTRY AUTO	69034	INSPECTION	47.70
BIG COUNTRY AUTO	69035	INSPECTION	85.27
BIG COUNTRY AUTO	69040	INSPECTION	73.55
BIG COUNTRY AUTO	69050	INSPECTION	47.70
BIG COUNTRY AUTO	69051	INSPECTION	47.70
BIG COUNTRY AUTO	69062	INSPECTION	47.70
BIG COUNTRY AUTO	69063	INSPECTION	47.70
BIG COUNTRY AUTO	69064	INSPECTION	47.70
		Vendor Total:	591.58
BILL BLANK AGENCY	1124	INSURANCE	159,601.00
		Vendor Total:	159,601.00
BLICK CLASSROOM ART	4065258	SUPPLIES	139.92
		Vendor Total:	139.92

<u>Vendor Name</u>	<u>Invoice</u>	<u>Description</u>	<u>Amount</u>	
BRADY & AMY'S	52649 B	FUEL	241.95	
BRADY & AMY'S	52650	FUEL	77.49	
BRADY & AMY'S	52807	FUEL	232.04	
				Vendor Total: 551.48
CENTRAL NEBRASKA REHAB SERVICES	0620 STMT	SERVICES	462.00	
				Vendor Total: 462.00
CHOICE FOODS	0720 STMT	SUPPLIES	289.67	
				Vendor Total: 289.67
CITY OF MADISON	0720 STMT	RENTAL	2,500.00	
CITY OF MADISON	50400 0720	UTILITIES	843.43	
CITY OF MADISON	50670 0720	UTILITIES	228.67	
CITY OF MADISON	50675 0720	UTILITIES	238.24	
CITY OF MADISON	70650 0720		2,584.81	
CITY OF MADISON	70700 0820	UTILITIES	6,432.18	
				Vendor Total: 12,827.33
CORNERSTONES OF CARE	0720 STMT	SERVICES	13,260.00	
				Vendor Total: 13,260.00
DABERKOW, PATRICK	0720 EXP	SERVICES	365.00	
				Vendor Total: 365.00
DENT SPECIALISTS	130346	SUPPLIES	38.00	
DENT SPECIALISTS	130413	REPAIRS	138.25	
DENT SPECIALISTS	130427	REPAIRS	23.00	
DENT SPECIALISTS	130514	REPAIRS	1,732.52	
				Vendor Total: 1,931.77
DUERST, BRANDON	1854	LAWN SERVICE	2,500.00	
				Vendor Total: 2,500.00
EAKES OFFICE SOLUTIONS	8065208-0	SUPPLIES	60.59	
EAKES OFFICE SOLUTIONS	8065208-1	SUPPLIES	16.49	
EAKES OFFICE SOLUTIONS	8069056-0	SUPPLIES	16.49	
EAKES OFFICE SOLUTIONS	C8065208-0	SUPPLIES	(16.49)	
				Vendor Total: 77.08
ECOLAB PEST ELIMINATION DIVISION	9654884	PEST CONTROL	81.85	
				Vendor Total: 81.85
EDUCATIONAL SERVICE UNIT #8	INV-006511	DISTANCE LEARNING	1,375.92	
				Vendor Total: 1,375.92
EGAN SUPPLY CO.	322491	SUPPLIES	99.18	
				Vendor Total: 99.18
EISENMANN SUPPLIES	S1888155689	SUPPLIES	21.98	
				Vendor Total: 21.98
FARM & RANCH BUILDING SUPPLY	5033288	SUPPLIES	134.40	
				Vendor Total: 134.40
FIELDS HARDWARE	174753	SUPPLIES	5.96	

<u>Vendor Name</u>	<u>Invoice</u>	<u>Description</u>	<u>Amount</u>	
FIELDS HARDWARE	174786	SUPPLIES	119.95	
FIELDS HARDWARE	174796	SUPPLIES	14.97	
FIELDS HARDWARE	174819	SUPPLIES	39.98	
FIELDS HARDWARE	174835	SUPPLIES	18.48	
		Vendor Total:		199.34
FILAMENT ESSENTIAL SERVICES	INV011665	WEB HOST	2,000.00	
		Vendor Total:		2,000.00
FIRST CHOICE FOOD SERVICE INC	3578	CATERING	236.50	
		Vendor Total:		236.50
FISCHER TREE CENTRAL, INC.	2014-2749	MAINTENANCE	350.00	
		Vendor Total:		350.00
FLOOR MAINTENANCE	Web-6833	SUPPLIES	69.16	
FLOOR MAINTENANCE	Web-7291	SUPPLIES	110.77	
		Vendor Total:		179.93
FRONTIER	0720 STMT	PHONE	704.94	
		Vendor Total:		704.94
GATES, RHONDA	0720 STMT	SERVICES	857.00	
		Vendor Total:		857.00
GREATAMERICA FINANCIAL SERVICES CORPORATION	27490338	COPIER LEASE	867.62	
		Vendor Total:		867.62
HIRERIGHT LLC, INC	P0971947	TESTING	281.40	
		Vendor Total:		281.40
INNOVATIVE OFFICE SOLUTIONS LLC	IN3015830 B	SUPPLIES	74.10	
INNOVATIVE OFFICE SOLUTIONS LLC	IN3015848 B	SUPPLIES	49.40	
INNOVATIVE OFFICE SOLUTIONS LLC	IN3024971	SUPPLIES	1,133.70	
INNOVATIVE OFFICE SOLUTIONS LLC	IN3024989	SUPPLIES	41.40	
INNOVATIVE OFFICE SOLUTIONS LLC	IN3024992	SUPPLIES	273.84	
INNOVATIVE OFFICE SOLUTIONS LLC	IN3025214	SUPPLIES	69.78	
		Vendor Total:		1,642.22
JACKSON SERVICES	4346548	SUPPLIES	56.37	
JACKSON SERVICES	4346549	SUPPLIES	40.78	
		Vendor Total:		97.15
JOURNEYED.COM	10372178	LICENSE	1,500.00	
		Vendor Total:		1,500.00
KSB SCHOOL LAW	8506	LEGAL SERVICES	272.00	
		Vendor Total:		272.00
MCGREGOR, ANDREA	0720 STMT	SERVICES	370.50	
		Vendor Total:		370.50
MENARDS - NORFOLK	89747	SUPPLIES	118.57	
MENARDS - NORFOLK	90504	SUPPLIES	274.29	
MENARDS - NORFOLK	90552	SUPPLIES	127.92	

<u>Vendor Name</u>	<u>Invoice</u>	<u>Description</u>	<u>Amount</u>	
			Vendor Total:	520.78
MPS ACTIVITY FUND	0720 REIMB	REIMBURSEMENT	6,420.00	
MPS ACTIVITY FUND	0720 STMT	REIMBURSEMENT	25.00	
			Vendor Total:	6,445.00
MUELLER SPRINKLERS	23589	MAINTENANCE	1,377.11	
			Vendor Total:	1,377.11
NAEA, NEBRASKA AG ED ASSOCIATION	2021 DUES	DUES	180.00	
			Vendor Total:	180.00
NATIONAL ART & SCHOOL SUPPLIES INC.	1194	SUPPLIES	1,179.70	
NATIONAL ART & SCHOOL SUPPLIES INC.	1292	SUPPLIES	336.68	
NATIONAL ART & SCHOOL SUPPLIES INC.	1395	SUPPLIES	775.21	
			Vendor Total:	2,291.59
NEBR RURAL COMMUNITY SCHOOLS	2021 MEMBERSHIP	MEMBERSHIP	850.00	
			Vendor Total:	850.00
NEBRASKA D LEAGUE	0720 EXP	COACHING	365.00	
			Vendor Total:	365.00
NEBRASKA PUBLIC HEALTH ENVIRONMENTAL LABORATORY	529483	WATER TESTING	15.00	
			Vendor Total:	15.00
NEBRASKA SAFETY CENTER PUPIL TRANSPORTATION	57-7852	REGISTRATION	475.00	
			Vendor Total:	475.00
NEWS CHANNEL NEBRASKA 35	20070142	ADVERTISING	195.00	
			Vendor Total:	195.00
ORPHAN GRAIN TRAIN	0720 STMT	SUPPLIES	1,125.00	
			Vendor Total:	1,125.00
PROFORMA	BS73001052A	SUPPLIES	414.75	
			Vendor Total:	414.75
PYRAMID SCHOOL PRODUCTS	S1411225.005 GEN	SUPPLIES	885.69	
PYRAMID SCHOOL PRODUCTS	S1411320.001	SUPPLIES	380.54	
PYRAMID SCHOOL PRODUCTS	S1412448.001 Gen	SUPPLIES	2,134.29	
			Vendor Total:	3,400.52
QUILL CORPORATION	8532439	SUPPLIES	389.96	
			Vendor Total:	389.96
ROSETTA STONE, THE	0720 STMT	LICENSE	4,650.00	
			Vendor Total:	4,650.00
RS ELECTRIC	1917	MAINTENANCE	2,850.00	
RS ELECTRIC	1918	MAINTENANCE	621.94	

<u>Vendor Name</u>	<u>Invoice</u>	<u>Description</u>	<u>Amount</u>	
			Vendor Total:	3,471.94
SCHOLASTIC, INC.	M6928161 6	SUPPLIES	260.98	
			Vendor Total:	260.98
SCHOOL DATEBOOKS	S20-0179864	SUPPLIES	262.40	
			Vendor Total:	262.40
SHORT STOP, THE	0720 STMT	FUEL	26.07	
			Vendor Total:	26.07
SPARKLIGHT (FORMERLY CABLE ONE)	0720 STMT	RENTAL	27.02	
			Vendor Total:	27.02
STUDENT ASSURANCE SERVICES INC	2021 INS	INSURANCE RENEWAL	803.50	
			Vendor Total:	803.50
SYMMETRY ENERGY SOLUTIONS	7731704	NATURAL GAS	1,122.48	
SYMMETRY ENERGY SOLUTIONS	8062864	NATURAL GAS	1,023.77	
			Vendor Total:	2,146.25
US BANK CARDMEMBER SERVICES	0720 STMT	SUPPLIES	1,384.60	
US BANK CARDMEMBER SERVICES	820 STMT	SUPPLIES	3,390.00	
			Vendor Total:	4,774.60
WALMART COMMUNITY	0720 STMT	SUPPLIES	421.67	
			Vendor Total:	421.67
WALTERS, CRYSTAL	0720 STMT	SERVICES	453.15	
			Vendor Total:	453.15
WATER ENGINEERING INC	IN50202	WATER SERVICE	250.04	
WATER ENGINEERING INC	IN50207	WATER SERVICE	175.00	
WATER ENGINEERING INC	IN50968	WATER SERVICE	175.00	
WATER ENGINEERING INC	IN50974	WATER SERVICE	250.04	
WATER ENGINEERING INC	IN57909	WATER SERVICE	175.00	
WATER ENGINEERING INC	IN57915	WATER SERVICE	250.04	
			Vendor Total:	1,275.12
			Fund Total:	251,137.77
			Checking Account Total:	251,137.77

September Board Meeting

Depreciation fund

McGraw Hill-\$7,287.93

Special Building fund

Fakler Architects-\$2,369.36

Mid-States Engineering & Testing-\$205.00

DWB, INC.-\$155,226.05

DWB, INC.-\$130,491.05

DWB, INC.-\$11,804.46

October Board Meeting

Depreciation fund

McGraw Hill-\$3765.85

DWB, Inc.-\$14,952.05

Special Building fund

DWB, Inc.-\$618,324.91

DWB, Inc.-\$139,772.40

Fakler Architects, LLC-\$508.08

November Board Meeting

Bond fund

BOK Financial-\$189,460.00

Special Building fund

DWB, Inc.-\$19,237.50

DWB, Inc.-\$187,756.19

DWB, Inc.-\$113,738.78

Fakler Architects, LLC-\$169.36

Mid-State Engineering & Testing-\$843.00

December Board Meeting

Depreciation fund

DWB, INC.-\$23,962.80

Special Building fund

MidState Engineering & Testing-\$889.00

Five Points Bank-\$678,554.37

DWB, INC.-\$250,070.96

DWB, INC.-\$83,411.61

Fakler Architects-\$169.36

January Board Meeting

Special Building Fund

DWB, Inc. - \$75,245.35 (MS Commons)

DWB, Inc. - \$132,185.85 (MHS Gym and Locker Room)

Mid State - \$710.00

Fakler Architects - \$6,419.36

Daktronics - \$91,626.00

Depreciation Fund

DWB, Inc. - \$32,427.30 (Bus Drop Off, Paving)

QCP Fund

Wells Fargo - \$1,002.58

February Board Meeting

Special Building Fund

DWB, Inc. - \$74,664.30	(MS Commons)
Mid State - \$1,574.50	
Fakler Architects - \$6,419.36	
DWB, Inc. - \$191,223.69	(MHS Gym and Locker Room)

March Board Meeting

Special Building fund

DWB, Inc. - \$68,160.15	(MS Commons)
DWB, Inc. - \$185,180.67	(MHS Gym and Locker Room)
Fakler Architechts - \$6,419.36	

QCP Fund

BOK Financial - \$766.47

April Board Meeting

Special Building fund

DWB, Inc.	\$82,096.98	(MHS Gym and Locker Room)
DWB, Inc.	\$33,607.86	(MS Commons)
Fakler Architechts	\$6,419.36	

May Board Meeting

Special Building fund

Fakler Architects	\$6,419.36	
DWB, Inc.	\$116,071.15	(MHS Gym and Locker Room)
DWB, Inc.	\$145,126.12	(MS Commons)

Bond Fund

BOK Financial \$17,760.00

June Board Meeting

Special Building fund

DWB, Inc.	\$27,958.50	(MHS Fire Sprinklers)
DWB, Inc.	\$111,609.43	(MS Commons)
DWB, Inc.	\$186,225.85	(MHS Gym and Locker Room)
Fakler Architects	\$6,419.36	
Five Points Bank	\$50,724.15	(Lease Debt Service)
Heartland Communications	\$3,254.00	(Optic Cable)
Heartland Communications	\$12,885.00	(Installation of Category 6 Data)
Love Signs	\$4,625.00	(Install Video Scoreboard)
Virco	\$18,219.66	(Furniture for middle school commons)

July Board Meeting

QCP Fund

Wells Fargo \$43,211.53

Special Building fund

Daktronics	\$3,415.00	(BackBoard Lighting kit and installation)
DWB, Inc.	\$185,623.98	(MHS Gym and Locker Rooms)
DWB, Inc.	\$45,468.42	(MS Commons)
DWB, Inc.	\$16,863.45	(MHS Fire Sprinklers)
Fakler Architects	\$6,419.36	

Depreciation Fund

DWB, Inc.	\$97,487.10 (Drop Off, Paving)
Freightliner	\$65,000.00 (Bus)

August Board Meeting

Depreciation Fund

Court Floors	\$2,560.00 Refinish gym floor
--------------	-------------------------------

DWB, Inc.	\$14,411.50 (Drop Off, Paving)
-----------	--------------------------------

Special Building Fund

DWB, Inc.	\$25,012.42 (MS Commons)
-----------	--------------------------

DWB, Inc.	\$913.96 (MHS Fire Sprinklers)
-----------	--------------------------------

DWB, Inc.	\$176,051.88 (MHS Gym and Locker Rooms)
-----------	---

Fakler Architects	\$6,419.36
-------------------	------------

Mid State Testing	\$455.00
-------------------	----------

July Approved Bills

Current Financial Position for Phase IV Project

Special Building Fund	Project/requirement	Current Funds	Estimate Cost or Goal	Actual Cost
	Gym and Locker rooms	\$3,912,547.00	\$3,592,191.00	\$3,119,215.66
	Middle School Addition	\$1,757,203.00	\$1,678,133.00	\$1,641,206.74
	Sprinklers	\$107,358.00	\$107,358.00	\$94,094.27
	Lease Repayment	\$875,000.00		\$874,925.75
	Working Capital	\$0.00		
	Balance as of November 2018	\$5,869,750.00		
	Total		\$5,377,682.00	\$5,729,442.42
Depreciation Fund				
	Concrete Replacement	\$928,244.00	\$339,071.00	
	Bus Drop Off	\$3,231.00	\$3,231.00	
	Total		\$342,302.00	\$184,607.80

MADISON PUBLIC SCHOOLS
TREASURER'S REPORT

July 31, 2020

General Fund

					<u>BALANCE</u>	<i>Last year's balance</i>
Balance Forward as of	<u>June 30, 2020</u>				\$4,191,544.39	
Receipts		+	\$	97,988.97		
Expenditures		-	\$	641,361.02		
Balance as of	<u>July 31, 2020</u>				\$3,648,172.34	\$2,885,995.75

Employee Benefit Fund

Balance Forward as of	<u>June 30, 2020</u>				\$14,444.94	
Receipts		+	\$	2,620.44		
Expenditures		-	\$	926.00		
Balance as of	<u>July 31, 2020</u>				\$16,139.38	\$12,830.87

Petty Cash Fund

Balance Forward as of	<u>June 30, 2020</u>				\$2,400.68	
Receipts		+	\$	2,382.50		
Expenditures		-	\$	2,352.75		
Balance as of	<u>July 31, 2020</u>				\$2,430.43	\$2,456.97

Total Assets for General Fund

\$3,666,742.15 \$2,901,283.59

Depreciation Fund

Balance Forward as of	<u>June 30, 2020</u>				\$724,689.23	
Receipts		+	\$	563.20		
Expenditures		-	\$	162,487.10		
Balance as of	<u>July 31, 2020</u>				\$562,765.33	\$823,389.10

Bond Fund

Balance Forward as of	<u>June 30, 2020</u>				\$112,692.07	
Receipts		+	\$	94.70		
Expenditures		-				
Balance as of	<u>July 31, 2020</u>				\$112,786.77	\$203,703.40

Qualified Capital Purpose Fund

Balance Forward as of	<u>June 30, 2020</u>				\$532,684.56	
Receipts		+	\$	8,556.39		
Expenditures		-	\$	50,679.15		
Balance as of	<u>July 31, 2020</u>				\$490,561.80	\$432,302.21

Special Building Fund

Balance Forward as of	<u>June 30, 2020</u>				\$2,178,760.53	
Receipts		+	\$	8,555.85		
Expenditures		-	\$	257,790.21		
Balance as of	<u>July 31, 2020</u>				\$1,929,526.17	\$5,342,861.05

Investment Checking

Balance Forward as of	<u>June 30, 2020</u>				\$324,875.42	
Receipts		+	\$	275.17		
Expenditures		-	\$	-		
Balance as of	<u>July 31, 2020</u>				\$325,150.59	\$320,146.38

LINE #	DESCRIPTION	BUDGET	General Fund Receipts	
			CURRENT RECEIPTS	
	TOTAL LOCAL	\$5,677,613	\$5,845,025	
	TOTAL STATE	\$662,273	\$534,510	
	TOTAL FEDERAL	\$414,249	\$790,429	
3155	Textbook Loan	\$0	\$5,356	
3500	Education Quest	\$0	\$2,989	
3512	Distance Learning	\$0	\$845	
3535	High Ability Learners	\$0	\$4,358	
4105	Erate	\$0	\$13,591	
4212	Title IA Support for Improvement	\$0	\$24,749	
4505	Title I	\$0	\$108,757	
4506	Title I Part A	\$0	\$5,038	
4507	SIG Middle School	\$0	\$54,314	
4508	Title ID Delinquent Ed.	\$0	\$25,201	
4509	Title IIA, Educator Quality	\$0	\$29,876	
4510	Title IV Part A	\$0	\$2,245	
4512	IDEA Base	\$0	\$40,871	
4516	IDEA Base P/S	\$0	\$1,056	
4519	IDEA Enrollment Poverty	\$0	\$68,544	
4521	Idea Prop Share	\$0	\$21,989	
4525	Perkins	\$0	\$6,749	
4526	Title IC Migrant Education	\$0	\$130,354	
4531	21st Century ASP	\$0	\$10,327	
4310	REAP	\$0	\$32,500	
4708	Medicaid in Public Schools	\$0	\$6,440	
4709	Neb-Mac Funds	\$0	\$9,990	
5400	NON-REVENUE SOURCES (SOP)	\$0	\$110,760	
6212	Title Support for Improvements		\$65,848	
	Other		\$7,683	
BUDGET OF EXPENDITURES				
			ESTIMATED	
		CURRENT BUDGET	CURRENT SPENDING	% Remaining
1100	REGULAR EDUCATION	\$4,275,000.00	\$3,261,982	24%
1200	SPECIAL EDUCATION	\$830,000	\$775,532	7%
2100/2150	SUPPORT SERVICES - PUPILS	\$390,000	\$298,305	24%
2200	SUPPORT SERVICES - STAFF	\$180,000	\$175,275	3%
2310	BOARD OF EDUCATION	\$68,000	\$37,141	45%
2320	EXECUTIVE ADMINISTRATION	\$200,000	\$178,839	11%
2330	DISTRICT LEGAL SERVICES	\$25,000	\$14,625	42%
2410	OFFICE OF THE PRINCIPAL	\$475,000	\$242,907	49%
2510	GENERAL ADMINISTRATION/BS	\$300,000	\$171,104	43%
2610	MAIN. & OPERATION OF BLDS.	\$1,046,000	\$472,540	55%
2710	REGULAR TRANSPORTATION	\$128,000	\$71,734	44%
2712	SCHOOL AGE SPED TRAN.	\$20,000	\$8,927	55%
2730	Vehicle Serv/Maintenance		\$3,124	
3155	Textbook Loan		\$5,190	
3535	HIGH ABILITY LEARNERS	\$2,500	\$7,192	-188%
6000	FEDERAL PROGRAMS	\$1,047,500	\$706,906	33%
8000	TRANSFER TO DEPRECIATION	\$0		
8000	TRANSFER TO ATHLETICS/LUNCH	\$0	\$60,000	
8000	TRANSFER TO OTHERS	\$38,000		100%
	BUDGET GROWTH	\$200,000.00		100%
	TOTAL BUDGET	\$9,025,000	\$6,491,023	28%

<u>Vendor Name</u>	<u>Invoice</u>	<u>Description</u>	<u>Amount</u>
Checking	5		
Checking	5	Fund: 05 ACTIVITY FUND	
BRANDL, DANA	Memorial- brother	Memorial - brother	25.00
		Vendor Total:	25.00
BSN SPORTS, LLC	909365758	Supplies	910.71
		Vendor Total:	910.71
CHOICE FOODS	1279	Prom - Water	13.75
		Vendor Total:	13.75
COMPLETE WEDDINGS & EVENTS	2,206,801	Homecoming 2020 - 9-19-2020	475.00
COMPLETE WEDDINGS & EVENTS	Prom-NOR	Prom - DJ & Photo Booth	905.00
		Vendor Total:	1,380.00
DEPEW, KIMBERLY	VB Camp-WSC	Volleyball Camp-WSC	120.00
		Vendor Total:	120.00
DHSDPH HEALTH LICENSING	Provisional License	Provisional Family Child Care License	25.00
		Vendor Total:	25.00
FIRST CHOICE FOOD SERVICE INC	3581	Prom 2020 meal	597.50
		Vendor Total:	597.50
HY-VEE FOOD STORES, INC	Grad Flowers	Graduation flower arrangement	135.00
		Vendor Total:	135.00
IMUS, ANDY	G BB Camp	G BB Camp	125.00
IMUS, ANDY	V*G BB Camp	G BB Camp	(125.00)
		Vendor Total:	0.00
INNOVATIVE OFFICE SOLUTIONS LLC	IN3015830-2	Supplies	34.20
		Vendor Total:	34.20
J & T SIDESHOTS PHOTOGRAPHY	Prom Pictures	Prom Pictures - release of rights	200.00
		Vendor Total:	200.00
LIMITED EDITION CAKES	Cupcakes	Cupcakes - teacher in- service	36.00
		Vendor Total:	36.00
MADISON SWIMMING POOL	Rental	Pool Rental - Weight Lifting	85.00
		Vendor Total:	85.00
MIDWEST GRADS	Grad Caps & Gowns	Graduation Caps/Gowns/Tassels/Stole Sets	1,514.00
		Vendor Total:	1,514.00
NATIONAL ART & SCHOOL SUPPLIES INC.	1395-1	Supplies	7.97
		Vendor Total:	7.97
NE SCHOOL ACTIVITIES ASSOC	2020-21 Act Reg	2020-21 Activities	1,050.00

<u>Vendor Name</u>	<u>Invoice</u>	<u>Description</u>	<u>Amount</u>	
		Registration		Vendor Total: 1,050.00
NORFOLK AREA SUMMER LEAGUE	VB Summer League	Volleyball Summer League	55.00	Vendor Total: 55.00
PIZZA HUT OF MADISON	7-29-20 #0001	Pizza-Weightroom Pool Party	62.45	Vendor Total: 62.45
PYRAMID SCHOOL PRODUCTS	S1411225.005	Supplies	729.63	Vendor Total: 729.63
RSCHOOLTODAY/DISTRIBUTED WEBSITE CORPORATION	47061	Training-1 hr	80.00	Vendor Total: 80.00
SAMUELSON, MARILYN	Memorial	Memorial - Mother-in-law	25.00	Vendor Total: 25.00
SCHOOL HEALTH CORPORATION	3760107-01-1	Supplies	1,050.10	Vendor Total: 1,050.10
UNKEL, NICOLE	Seward VB Camp	Seward VB Camp - student paid portion	115.00	Vendor Total: 115.00
UPS	0000X87Y64290	Shipment-Academy of Honor Award	18.60	Vendor Total: 18.60
WILD ROOTS GREENHOUSE & MARKET	263	Vegetable plants	68.80	Vendor Total: 68.80
				Fund Total: 8,338.71
				Checking Account Total: 8,338.71

MADISON PUBLIC SCHOOLS					
Activity Fund Balance Report					
JULY 2020		Fund 05			
<u>Chart of Account Description</u>	<u>Beg Balance</u>	<u>Expenses</u>	<u>Revenues</u>	<u>Bal Change</u>	<u>Balance</u>
FUND BALANCE	0.00	0.00	0.00	30,000.00	30,000.00
AD	6,926.24	3,862.61	0.00	0.00	3,063.63
Art Club	516.24	0.00	0.00	0.00	516.24
Band	4,328.55	0.00	0.00	0.00	4,328.55
Boys BB	1,496.42	0.00	0.00	0.00	1,496.42
Boys BB FR	486.91	0.00	0.00	0.00	486.91
Cheerleaders	72.69	0.00	0.00	0.00	72.69
Class of 2019	635.43	0.00	0.00	0.00	635.43
Class of 2020	2,383.22	1,649.00	0.00	0.00	734.22
Class of 2021	2,953.97	1,716.25	0.00	0.00	1,237.72
Class of 2022	1,076.22	0.00	0.00	0.00	1,076.22
Class of 2023	300.00	0.00	0.00	0.00	300.00
Concessions	14,627.71	0.00	0.00	0.00	14,627.71
Courtesy	2,548.20	50.00	0.00	0.00	2,498.20
Cross Country	42.04	0.00	71.40	0.00	113.44
Cross Country FR	1,054.61	0.00	0.00	0.00	1,054.61
Danceline	400.26	0.00	0.00	0.00	400.26
District Funds	11,557.95	25.00	155.72	0.00	11,688.67
Educators Rising	867.28	0.00	0.00	0.00	867.28
Elem Activity Acct	4,762.77	0.00	0.00	0.00	4,762.77
Elem PTO	1,684.47	0.00	0.00	0.00	1,684.47
Elem Student Council	47.00	0.00	0.00	0.00	47.00
ELL Class	630.75	0.00	0.00	0.00	630.75
Emergency Assistance	1,533.24	0.00	0.00	0.00	1,533.24
Ethnic Diversity Club	1,740.53	0.00	0.00	0.00	1,740.53
FCCLA	856.83	0.00	0.00	0.00	856.83
FFA	4,415.68	68.80	165.00	0.00	4,511.88
Football	1,958.55	0.00	0.00	0.00	1,958.55
Football FR	688.71	0.00	0.00	0.00	688.71
Football Youth	250.00	0.00	0.00	0.00	250.00
Girls BB	1,263.98	0.00	0.00	0.00	1,263.98
Girls BB FR	507.66	0.00	0.00	0.00	507.66
Golf	883.76	0.00	0.00	0.00	883.76
Golf FR	192.35	0.00	0.00	0.00	192.35
Homecoming	1,153.22	475.00	0.00	0.00	678.22
Honor Society	876.57	0.00	0.00	0.00	876.57
HS Student Council	1,151.40	18.60	0.00	0.00	1,132.80
M Club	4,952.68	0.00	0.00	0.00	4,952.68
Marketing Comm.	22,472.19	36.00	0.00	0.00	22,436.19
MS Activity Acct	4,505.32	0.00	0.00	0.00	4,505.32
MS Houses	665.94	0.00	950.00	0.00	1,615.94

Music Boosters	5,286.07	0.00	0.00	0.00	5,286.07
Musical	3,053.80	0.00	0.00	0.00	3,053.80
One Act Plays	605.46	0.00	0.00	0.00	605.46
Quiz Bowl	623.01	0.00	0.00	0.00	623.01
Resale	491.03	0.00	0.00	0.00	491.03
Scholarships	11,172.35	0.00	636.08	0.00	11,808.43
Secondary Act Acct	6,672.29	0.00	0.00	0.00	6,672.29
Soccer	5,443.40	0.00	0.00	0.00	5,443.40
Soccer FR	3,712.57	0.00	150.00	0.00	3,862.57
Softball	754.35	0.00	0.00	0.00	754.35
Softball FR	1,140.16	0.00	30.00	0.00	1,170.16
Speech	158.86	0.00	0.00	0.00	158.86
Teachers	2,142.74	0.00	0.00	0.00	2,142.74
Track	1,066.42	0.00	0.00	0.00	1,066.42
Track FR	205.39	0.00	0.00	0.00	205.39
Uniform Replacement	5,533.95	0.00	0.00	0.00	5,533.95
Volleyball	316.82	0.00	0.00	0.00	316.82
Volleyball FR	1,503.16	290.00	45.00	0.00	1,258.16
Water Quality Project	4,160.11	0.00	0.00	0.00	4,160.11
Weightroom	351.63	147.45	0.00	0.00	204.18
Wrestling	4,048.42	0.00	174.40	0.00	4,222.82
Wrestling FR	422.98	0.00	0.00	0.00	422.98
Yearbook	1,148.74	0.00	0.00	0.00	1,148.74
	169,481.25	8,338.71	2,377.60	30,000.00	193,520.14
					FUND 05

Lunch Fund Balance Report					
JULY 2020	Fund 06				
<u>Chart of Account Description</u>	<u>Beg Balance</u>	<u>Expenses</u>	<u>Revenues</u>	<u>Bal Change</u>	<u>Balance</u>
FUND BALANCE	21,359.40	2,029.98	30,185.28	0.00	49,514.70
					FUND 06

Student Fund Balance Report					
JULY 2020	Fund 12				
<u>Chart of Account Description</u>	<u>Beg Balance</u>	<u>Expenses</u>	<u>Revenues</u>	<u>Bal Change</u>	<u>Balance</u>
FUND BALANCE	25.57	0.00	0.00	0.00	25.57
					<u>FUND 12</u>

APPLICATION AND CERTIFICATE FOR PAYMENT

TO OWNER:
 Madison Public Schools
 PO Box 450
 Madison, NE 68748
 FROM CONTRACTOR:
 dwb, inc
 PO Box 626
 Madison, NE 68748
 CONTRACT FOR:

PROJECT:
 MHS BUS DROP, PAVING
 Site Paving, Bus Drop
 VIA ARCHITECT:
 Fakler Architects
 1001 N 6th St
 Beatrice, NE 68310

APPLICATION #: 8
 PERIOD TO: 07/30/20
 PROJECT NOS:
 DISTRIBUTION TO:
 Owner
 Const. Mgr
 Architect
 Contractor
 CONTRACT DATE: 12/11/18

CONTRACTOR'S APPLICATION FOR PAYMENT

Application is made for payment, as shown below, in connection with the Contract. Continuation Sheet is attached.

1. ORIGINAL CONTRACT SUM	\$	342,302.00
2. Net change by Change Orders	\$	
3. CONTRACT SUM TO DATE (Line 1 +/- 2)	\$	342,302.00
4. TOTAL COMPLETED & STORED TO DATE	\$	209,494.00
(Column G on Continuation Sheet)		
5. RETAINAGE:		
a. 5.0% of Completed Work (Columns D+E on Continuation Sheet)	\$	10,474.70
b. 5.0% of Stored Material (Column F on Continuation Sheet)	\$	
Total Retainage (Line 5a + 5b or Total in Column I of Continuation Sheet)	\$	10,474.70
6. TOTAL EARNED LESS RETAINAGE	\$	199,019.30
(Line 4 less Line 5 Total)		
7. LESS PREVIOUS CERTIFICATES FOR PAYMENT (Line 6 from prior Certificate)	\$	184,607.80
8. CURRENT PAYMENT DUE	\$	14,411.50
9. BALANCE TO FINISH, INCLUDING RETAINAGE (Line 3 less Line 6)	\$	143,282.70

The undersigned Contractor certifies that to the best of the Contractor's knowledge, information and belief the Work covered by this Application for Payment has been completed in accordance with the Contract Documents, that all amounts have been paid by the Contractor for Work for which previous Certificates for Payment were issued and payments received from the Owner, and that current payment shown therein is now due.

CONTRACTOR: Jou Fredel
 By: _____ Date: July 29, 2020

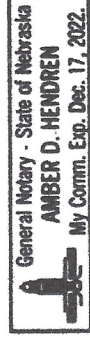

State of: Nebraska
 County of: Madison
 Subscribed and sworn to before me this 29 day of July, 2020

Notary Public: Amber D. Hendren
 My Commission expires: 12-17-22

CERTIFICATE FOR PAYMENT

In accordance with Contract Documents, based on on-site observations and the data comprising application, the Architect certifies to the Owner that to the best of the Architect's knowledge, information and belief the Work has progressed as indicated, the quality of the Work is in accordance with the Contract Documents, and the Contractor is entitled to payment of the AMOUNT CERTIFIED.

AMOUNT CERTIFIED \$ 14,411.50
 (Attach explanation if amount certified differs from the amount applied for. Initial all figures on this application and on the Continuation Sheet that are changed to conform to the amount certified.)

CHANGE ORDER SUMMARY	ADDITIONS	DEDUCTIONS
Total changes approved in previous months by Owner		
Total approved this Month		
TOTALS		
NET CHANGES by Change Order		

ARCHITECT: Michael D. Faber Date: 8/6/2020
 By: _____
 This Certificate is not negotiable. The AMOUNT CERTIFIED is payable only to the Contractor named herein. Issuance, payment and acceptance of payment are without prejudice to any rights of the Owner of Contractor under this Contract.

APPLICATION AND CERTIFICATE FOR PAYMENT

TO OWNER:
 Madison Public Schools
 PO Box 450
 Madison, NE 68748

FROM CONTRACTOR:
 dwb, inc
 PO Box 626
 Madison, NE 68748

PROJECT:
 MHS MEZZ-COMMONS-RR
 Mezz, Commons, Concession, RR
 Madison, NE

VIA ARCHITECT:
 Fakler Architects
 1001 N 6th St
 Beatrice, NE 68310

CONTRACT FOR:

APPLICATION #: 18
 PERIOD TO: 07/29/20
 PROJECT NOS:
 CONTRACT DATE: 12/11/18

Distribution to:
 Owner
 Const. Mgr
 Architect
 Contractor

CONTRACTOR'S APPLICATION FOR PAYMENT

Application is made for payment, as shown below, in connection with the Contract. Continuation Sheet is attached.

The undersigned Contractor certifies that to the best of the Contractor's knowledge, information and belief the Work covered by this Application for Payment has been completed in accordance with the Contract Documents, that all amounts have been paid by the Contractor for Work for which previous Certificates for Payment were issued and payments received from the Owner, and that current payment shown therein is now due.

- 1. ORIGINAL CONTRACT SUM-----\$ 1,678,133.00
- 2. Net change by Change Orders-----\$ 57,114.74
- 3. CONTRACT SUM TO DATE (Line 1 +/- 2) \$ 1,735,247.74
- 4. TOTAL COMPLETED & STORED TO DATE-\$ (Column G on Continuation Sheet) 1,690,874.57

- 5. RETAINAGE:
 - a. 5.0% of Completed Work (Columns D+E on Continuation Sheet) \$ 84,543.73
 - b. 5.0% of Stored Material (Column F on Continuation Sheet) \$
 - Total Retainage (Line 5a + 5b or Total in Column I of Continuation Sheet)-----\$ 84,543.73

- 6. TOTAL EARNED LESS RETAINAGE-----\$ 1,606,330.84
- (Line 4 less Line 5 Total)

- 7. LESS PREVIOUS CERTIFICATES FOR PAYMENT (Line 6 from prior Certificate)-----\$ 1,581,318.42

- 8. CURRENT PAYMENT DUE-----\$ 25,012.42
- 9. BALANCE TO FINISH, INCLUDING RETAINAGE (Line 3 less Line 6) \$ 128,916.90

CONTRACTOR:

By: _____ Date: July 29, 2020

State of: Nebraska
 County of: Madison
 Subscribed and sworn to before me this _____ day of July, 2020

Notary Public: _____
 My Commission expires: _____

CERTIFICATE FOR PAYMENT

In accordance with Contract Documents, based on on-site observations and the data comprising application, the Architect certifies to the Owner that to the best of the Architect's knowledge, information and belief the Work has progressed as indicated, the quality of the Work is in accordance with the Contract Documents, and the Contractor is entitled to payment of the AMOUNT CERTIFIED.

AMOUNT CERTIFIED ----- \$ 25,012.42
 (Attach explanation if amount certified differs from the amount applied for. Initial all figures on this application and on the Continuation Sheet that are changed to conform to the amount certified.)

CHANGE ORDER SUMMARY	ADDITIONS	DEDUCTIONS
Total changes approved in previous months by Owner	\$57,114.74	
Total approved this Month		
TOTALS	\$57,114.74	
NET CHANGES by Change Order		\$57,114.74

ARCHITECT: Michael D. Fakler Date: 8/6/2020

This Certificate is not negotiable. The AMOUNT CERTIFIED is payable only to the Contractor named herein. Issuance, payment and acceptance of payment are without prejudice to any rights of the Owner of Contractor under this Contract.

APPLICATION AND CERTIFICATE FOR PAYMENT

TO OWNER:
 Madison Public Schools
 PO Box 450
 Madison, NE 68748
FROM CONTRACTOR:
 dwb, inc
 PO Box 626
 Madison, NE 68748
CONTRACT FOR:

PROJECT:
 MHS FIRE SPRINKLERS
 Fire Sprinkler System
 Madison, NE
VIA ARCHITECT:
 Fakler Architects
 1001 N 6th St
 Beatrice, NE 68310

APPLICATION #: 10
PERIOD TO: 07/30/20
PROJECT NOS:
CONTRACT DATE: 12/11/18
Distribution to:

X	Owner
X	Const. Mgr
X	Architect
X	Contractor

CONTRACTOR'S APPLICATION FOR PAYMENT

Application is made for payment, as shown below, in connection with the Contract. Continuation Sheet is attached.

1. ORIGINAL CONTRACT SUM -----	\$	107,358.00
2. Net change by Change Orders -----	\$	-10,102.00
3. CONTRACT SUM TO DATE (Line 1 +/- 2)	\$	97,256.00
4. TOTAL COMPLETED & STORED TO DATE-\$ (Column G on Continuation Sheet)	\$	96,244.81
5. RETAINAGE:		
a. 5.0% of Completed Work (Columns D+E on Continuation Sheet)	\$	4,812.24
b. 5.0% of Stored Material (Column F on Continuation Sheet) Total Retainage (Line 5a + 5b or Total in Column I of Continuation Sheet)-----	\$	4,812.24
6. TOTAL EARNED LESS RETAINAGE ----- (Line 4 less Line 5 Total)	\$	91,432.57
7. LESS PREVIOUS CERTIFICATES FOR PAYMENT (Line 6 from prior Certificate)-----	\$	90,518.61
8. CURRENT PAYMENT DUE -----	\$	913.96
9. BALANCE TO FINISH, INCLUDING RETAINAGE (Line 3 less Line 6)	\$	5,823.43

CONTRACTOR:

By: Joni Truck Date: July 30, 2020

State of: Nebraska
 County of: Madison
 Subscribed and sworn to before
 me this 30th day of July, 2020



Notary Public: Morgan Reitz
 My Commission expires: _____

CERTIFICATE FOR PAYMENT

In accordance with Contract Documents, based on on-site observations and the data comprising application, the Architect certifies to the Owner that to the best of the Architect's knowledge, information and belief the Work has progressed as indicated, the quality of the Work is in accordance with the Contract Documents, and the Contractor is entitled to payment of the AMOUNT CERTIFIED.

AMOUNT CERTIFIED ----- \$ 913.96
 (Attach explanation if amount certified differs from the amount applied for. Initial all figures on this application and on the Continuation Sheet that are changed to conform to the amount certified.)

CHANGE ORDER SUMMARY	ADDITIONS	DEDUCTIONS
Total changes approved in previous months by Owner		-\$10,102.00
Total approved this Month		
TOTALS		-\$10,102.00
NET CHANGES by Change Order		-\$10,102.00

ARCHITECT:
 By: Michael D. Falber Date: 8/6/2020

This Certificate is not negotiable. The AMOUNT CERTIFIED is payable only to the Contractor named herein. Issuance, payment and acceptance of payment are without prejudice to any rights of the Owner of Contractor under this Contract.

APPLICATION AND CERTIFICATE FOR PAYMENT

TO OWNER:
 Madison Public Schools
 PO Box 450
 Madison, NE 68748
FROM CONTRACTOR:
 dwb, inc
 PO Box 626
 Madison, NE 68748
CONTRACT FOR:

PROJECT:

GYM & LOCKER ROOM
 Gym & Locker Addition

VIA ARCHITECT:

Fakler Architects
 1001 N 6th St
 Beatrice, NE 68310

APPLICATION #: 18
PERIOD TO: 07/30/20
PROJECT NOS:

Distribution to:

X	Owner
X	Const. Mgr
X	Architect
X	Contractor

CONTRACT DATE: 12/11/18

CONTRACTOR'S APPLICATION FOR PAYMENT

Application is made for payment, as shown below, in connection with the Contract. Continuation Sheet is attached.

1. ORIGINAL CONTRACT SUM -----	\$	3,592,191.00
2. Net change by Change Orders -----	\$	59,811.18
3. CONTRACT SUM TO DATE (Line 1 +/- 2)	\$	3,652,002.18
4. TOTAL COMPLETED & STORED TO DATE-\$ (Column G on Continuation Sheet)	\$	3,360,481.83

5. RETAINAGE:

- a. 5.0% of Completed Work (Columns D+E on Continuation Sheet) \$ 168,024.09
 - b. 5.0% of Stored Material (Column F on Continuation Sheet) \$
- Total Retainage (Line 5a + 5b or Total in Column I of Continuation Sheet)-----

6. TOTAL EARNED LESS RETAINAGE ----- (Line 4 less Line 5 Total)	\$	168,024.09
7. LESS PREVIOUS CERTIFICATES FOR PAYMENT (Line 6 from prior Certificate)-----	\$	3,192,457.74

8. CURRENT PAYMENT DUE-----

	\$	3,017,257.07
	\$	175,200.67
	\$	476,054.88

9. BALANCE TO FINISH, INCLUDING RETAINAGE
(Line 3 less Line 6)

\$ 459,544.44

CHANGE ORDER SUMMARY	ADDITIONS	DEDUCTIONS
Total changes approved in previous months by Owner	\$59,811.18	
Total approved this Month		
TOTALS	\$59,811.18	
NET CHANGES by Change Order		\$59,811.18

The undersigned Contractor certifies that to the best of the Contractor's knowledge, information and belief the Work covered by this Application for Payment has been completed in accordance with the Contract Documents, that all amounts have been paid by the Contractor for Work for which previous Certificates for Payment were issued and payments received from the Owner, and that current payment shown therein is now due.

CONTRACTOR

By: Joni Frisch Date: July 30, 2020

State of: Nebraska

County of: Madison

Subscribed and sworn to before me this 30th day of July, 2020

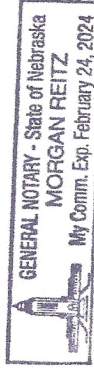

Notary Public: Morgan Reitz

My Commission expires: _____

CERTIFICATE FOR PAYMENT

In accordance with Contract Documents, based on on-site observations and the data comprising application, the Architect certifies to the Owner that to the best of the Architect's knowledge, information and belief the Work has progressed as indicated, the quality of the Work is in accordance with the Contract Documents, and the Contractor is entitled to payment of the AMOUNT CERTIFIED.

AMOUNT CERTIFIED ----- \$ 175,200.67
 (Attach explanation if amount certified differs from the amount applied for. Initial all figures on this application and on the Continuation Sheet that are changed to conform to the amount certified.)

ARCHITECT:

By: Michael D. Fahlner

Date: 8/6/2020

This Certificate is not negotiable. The AMOUNT CERTIFIED is payable only to the Contractor named herein. Issuance, payment and acceptance of payment are without prejudice to any rights of the Owner of Contractor under this Contract.

CONTINUATION SHEET

ATTACHMENT TO PAY APPLICATION

APPLICATION NUMBER: 8

PROJECT:

APPLICATION DATE: 07/30/20

MHS BUS DROP, PAVING

PERIOD TO: 30-Jul-20

Site Paving, Bus Drop

ARCHITECT'S PROJECT NO:

A Item No.	B Description of Work	C Scheduled Value	D Work Completed		E This Period	F Materials Presently Stored (Not In D or E)	G Total Completed And Stored To Date (D + E + F)	H Balance To Finish (C - G)	I Retainage (If Variable Rate)
			From Previous Application (D + E)	This Period					
1	General	46,952.00	18,104.00	10,000.00		28,104.00	18,848.00		
2	Footing & Retaining Wall	76,000.00	76,000.00			76,000.00			
3	Paving, Curb & Gutter	192,507.00	73,377.00	5,170.00		78,547.00	113,960.00		
4	Bus Drop Off Paving	3,231.00	3,231.00			3,231.00			
5	Site Grading	23,612.00	23,612.00			23,612.00			
6									
7									
8									
9									
10									
11									
12									
13									
14									
15									
16									
17									
18									
19									
20									
21									
22									
23									
24									
25									
26									
27									
28									
SUBTOTALS PAGE 2		342,302.00	194,324.00	15,170.00		209,494.00	132,808.00	61%	

CONTINUATION SHEET

ATTACHMENT TO PAY APPLICATION

APPLICATION NUMBER: 18

PROJECT:

APPLICATION DATE: 07/29/20

MHS MEZZ-COMMONS-RR

PERIOD TO: 29-Jul-20

Mezz, Commons, Concession, RR

Madison, NE

ARCHITECT'S PROJECT NO:

A Item No.	B Description of Work	C Scheduled Value	D Work Completed		E This Period	F Materials Presently Stored (Not In D or E)	G Total Completed And Stored To Date (D + E + F)	% (G/C)	H Balance To Finish (C - G)	I Retainage (If Variable Rate)
			From Previous Application (D + E)	This Period						
1	General	111,412.00	105,480.00	5,932.00			111,412.00	100%		
2	Demolition	6,685.00	6,685.00				6,685.00	100%		
3	Grading	49,600.00	49,600.00				49,600.00	100%		
4	Termite Treatment	929.00	929.00				929.00	100%		
5	Fill & Backfill	6,000.00	6,000.00				6,000.00	100%		
6	Helical Piles	113,000.00	113,000.00				113,000.00	100%		
7	Footings, Cast in Place Walls	139,000.00	139,000.00				139,000.00	100%		
8	Steel Reinforcement	28,614.00	28,614.00				28,614.00	100%		
9	Concrete: Floors, Steps, Stoop	33,646.00	33,646.00				33,646.00	100%		
10	Steel Erection	40,000.00	39,375.00	625.00			40,000.00	100%		
11	Masonry	78,500.00	78,500.00				78,500.00	100%		
12	Structural Steel	133,200.00	133,200.00				133,200.00	100%		
13	Rough Framing Carpentry	15,164.00	15,164.00				15,164.00	100%		
14	Finish Carpentry	2,480.00	2,480.00				2,480.00	100%		
15	Foam Fill Insulation	1,730.00	1,730.00				1,730.00	100%		
16	Foam Board Insulation	380.00	380.00				380.00	100%		
17	Rolled Air Barriers	8,557.00	8,557.00				8,557.00	100%		
18	Fluid Air Barrer & Flashings	3,475.00	3,475.00				3,475.00	100%		
19	Metal Roof, Siding, Soffit, FI	182,666.00	171,198.11	7,549.58			178,747.69	98%	3,918.31	
20	Existing Roof Tie In	5,000.00	5,000.00				5,000.00	100%		
21	Sealants	900.00	900.00				900.00	100%		
22	HM Doors & Frames	23,088.00	1,500.00	21,588.00			23,088.00	100%		
23	Coiling Doors	6,901.00	6,901.00				6,901.00	100%		
24	Aluminum Doors, Frames, Window	100,131.00	62,732.34				62,732.34	63%	37,398.66	
25	Metal Framing & Drywall	71,880.00	71,860.00	20.00			71,880.00	100%		
26	Ceramic Tile	41,715.00	39,482.80	2,232.20			41,715.00	100%		
27	Acoustical Ceiling	2,632.00	2,632.00				2,632.00	100%		
28	Painting	16,772.00	16,772.00				16,772.00	100%		
SUBTOTALS PAGE 2		1,224,057.00	1,144,793.25	37,946.78			1,182,740.03	97%	41,316.97	

CONTINUATION SHEET

ATTACHMENT TO PAY APPLICATION

APPLICATION NUMBER: 10

PROJECT:

APPLICATION DATE: 07/30/20

MHS FIRE SPRINKLERS

PERIOD TO: 30-Jul-20

Fire Sprinkler System

ARCHITECT'S PROJECT NO:

Madison, NE

A Item No.	B Description of Work	C Scheduled Value	D Work Completed		E Completed This Period	F Materials Presently Stored (Not In D or E)	G Total Completed And Stored To Date (D + E + F)	% (G/C)	H Balance To Finish (C - G)	I Retainage (If Variable Rate)
			From Previous Application (D + E)	This Period						
1	General	5,255.00	5,255.00		962.06		5,255.00	100%		
2	Fire Sprinklers	102,103.00	100,129.75				101,091.81	99%	1,011.19	
3	C.O. #1	(10,102.00)	(10,102.00)				(10,102.00)			
4										
5										
6										
7										
8										
9										
10										
11										
12										
13										
14										
15										
16										
17										
18										
19										
20										
21										
22										
23										
24										
25										
26										
27										
28										
SUBTOTALS PAGE 2		97,256.00	95,282.75		962.06		96,244.81	99%	1,011.19	

CONTINUATION SHEET

ATTACHMENT TO PAY APPLICATION

PROJECT:

GYM & LOCKER ROOM
Gym & Locker Addition

APPLICATION NUMBER: 18

APPLICATION DATE: 07/30/20

PERIOD TO: 30-Jul-20

ARCHITECT'S PROJECT NO:

A Item No.	B Description of Work	C Scheduled Value	D Work Completed		E This Period	F Materials Presently Stored (Not In D or E)	G Total Completed And Stored To Date (D + E + F)	H Balance To Finish (C - G)	I Retainage (If Variable Rate)
			From Previous Application (D + E)	% (G/C)					
1	General	489,556.00	449,371.00		25,000.00		474,371.00	15,185.00	
2	Guard Rail, Striping, Signs	9,250.00	3,200.00				3,200.00	6,050.00	
3	Drain Tile	5,980.00	5,456.00		524.00		5,980.00		
4	Termite Treatment	2,618.00	2,618.00				2,618.00		
5	Dumpster, Fencing, Erosion Control	6,800.00	6,800.00				6,800.00		
6	Grading	30,000.00	30,000.00				30,000.00		
7	Landscape	7,200.00						7,200.00	
8	Fill & Backfill	6,000.00	6,000.00				6,000.00		
9	Footings & Cast in Place Walls	168,000.00	168,000.00				168,000.00		
10	Steel Reinforcement	20,148.00	20,148.00				20,148.00		
11	Concrete Floors, Steps, Stoops	43,470.00	43,470.00				43,470.00		
12	Precast Panels	395,000.00	395,000.00				395,000.00		
13	Precast & Steel Erection	197,300.00	187,400.00				187,400.00	9,900.00	
14	Masonry	211,500.00	211,500.00				211,500.00		
15	Structural Steel	174,500.00	170,363.75		4,136.25		174,500.00		
16	Rough Framing Carpentry	19,604.00	19,604.00				19,604.00		
17	Finish Carpentry	3,646.00	3,646.00				3,646.00		
18	Fluid Applied Waterproofing	6,988.00	6,988.00				6,988.00		
19	Foam Fill Insulation	3,000.00	3,000.00				3,000.00		
20	Foam Board Insulation	780.00	780.00				780.00		
21	Air Barriers & Flashings	21,893.00	21,893.00				21,893.00		
22	M Roof, Siding, Soffits, Flashing	328,700.00	228,975.18				228,975.18	99,724.82	
23	Sealants	4,500.00	3,500.00		1,000.00		4,500.00		
24	HM Doors & Frames	42,703.00	35,888.00		6,815.00		42,703.00		
25	Hatch Doors	1,400.00	1,400.00				1,400.00		
26	Overhead Doors	3,551.00	3,551.00				3,551.00		
27	Alum Doors, Frames, Windows	57,064.00	11,860.00				11,860.00	45,204.00	
28	Metal Framing & Drywall	23,940.00	23,695.00		245.00		23,940.00		
SUBTOTALS PAGE 2		2,285,091.00	2,064,106.93		37,720.25		2,101,827.18	183,263.82	

CONTINUATION SHEET

6930
20257
9241
16106

Page 3 of 2 Pages

ATTACHMENT TO PAY APPLICATION

APPLICATION NUMBER: 18

APPLICATION DATE: 07/29/20

PERIOD TO: 29-Jul-20

PROJECT:
MHS MEZZ-COMMONS-RR
Mezz, Commons, Concession, RR
Madison, NE

ARCHITECT'S PROJECT NO.

A Item No.	B Description of Work	C Scheduled Value	D Work Completed		E Completed This Period	F Materials Presently Stored (Not In D or E)	G Total Completed And Stored To Date (D + E + F)	% (G/C)	H Balance To Finish (C - G)	I Retainage (If Variable Rate)
			From Previous Application (D + E)							
29	Resin Floors	6,930.00	6,930.00				6,930.00	100%		
30	RR Stalls & Accessories	20,257.00	20,257.00				20,257.00	100%		
31	Laminate Casework	9,241.00	9,241.00				9,241.00	100%		
32	Fire Sprinklers	16,106.00	10,156.00	5,950.00			16,106.00	100%		
33	Plumbing	151,038.00	110,615.00	40,423.00			151,038.00	100%		
34	HVAC	151,039.00	75,410.00	75,629.00			151,039.00	100%		
35	Electrical	99,465.00	77,394.00	22,071.00			99,465.00	100%		
36	C.O. #1	13,000.10	12,768.00	232.10			13,000.10	100%		
37	C.O. #2	2,877.80	2,877.00	0.80			2,877.80	100%		
38	C.O. #3	10,111.84	10,071.40	40.44			10,111.84	100%		
39	C.O. #4	3,485.20	429.00				429.00	12%	3,056.20	
40	C.O. #5	14,040.70	10,813.00	3,227.70			14,040.70	100%		
41	C.O. #6	13,599.10	13,599.10				13,599.10	100%		
42										
43										
44										
45										
46										
47										
48										
49										
50										
51										
52										
53										
54										
55										
56										
SUBTOTALS PAGE 3		1,735,247.74	1,505,353.75	185,520.82			1,690,874.57	97%	44,373.17	

CONTINUATION SHEET

ATTACHMENT TO PAY APPLICATION

APPLICATION NUMBER: 18

PROJECT:

APPLICATION DATE: 07/30/20

GYM & LOCKER ROOM

PERIOD TO: 30-Jul-20

Gym & Locker Addition

ARCHITECT'S PROJECT NO.:

A Item No.	B Description of Work	C Scheduled Value	D Work Completed		E This Period	F Materials Presently Stored (Not In D or E)	G Total Completed And Stored To Date (D + E + F)	H Balance To Finish (C - G)	I Retainage (If Variable Rate)
			From Previous Application (D + E)	This Period					
29	Ceramic Tile	21,637.00	21,430.05	206.95			21,637.00	100%	
30	Acoustical Ceiling	7,399.00	7,399.00				7,399.00	100%	
31	Painting	23,923.00	21,586.00				21,586.00	90%	2,337.00
32	Resin Floors	22,400.00	22,400.00				22,400.00	100%	
33	Wood Gym Floor	126,900.00	76,345.00	50,555.00			126,900.00	100%	
34	RR Stalls & Accessories	21,079.00	17,133.50	3,945.50			21,079.00	100%	
35	Lockers	18,500.00	18,500.00				18,500.00	100%	
36	Gym Equipment	36,122.00	36,122.00				36,122.00	100%	
37	Laminate Casework	24,760.00	24,760.00				24,760.00	100%	
38	Telescopic Bleachers	90,675.00							90,675.00
39	Elevator	71,166.00	25,392.00	44,052.00			69,444.00	98%	1,722.00
40	Fire Sprinklers	22,791.00	22,790.40	0.60			22,791.00	100%	
41	HVAC	195,285.00	195,285.00				195,285.00	100%	
42	Plumbing	195,285.00	195,285.00				195,285.00	100%	
43	Site Utilities	234,000.00	191,370.25	33,184.00			224,554.25	96%	9,445.75
44	Electrical	195,178.00	194,282.00				194,282.00	100%	896.00
45	CO #1 Unsuitable Soils	10,556.30	10,556.30				10,556.30	100%	
46	CO #2	5,249.10	5,249.10				5,249.10	100%	
47	CO #3	5,716.18	5,240.00				5,240.00	92%	476.18
48	CO #4	13,971.60	8,218.00	3,049.00			11,267.00	81%	2,704.60
49	CO #5	10,786.60	6,169.55	4,617.05			10,786.60	100%	
50	CO #6	13,531.40	5,020.00	8,511.40			13,531.40	100%	
51									
52									
53									
54									
55									
56									
SUBTOTALS PAGE 3		3,652,002.18	3,174,640.08	185,841.75			3,360,481.83	92%	291,520.35

PARTIAL WAIVER & RELEASE OF LIEN

PROJECT

SUBCONTRACTOR

CONTRACTOR

Madison High School IV Gym/Commons 700 S Kent St Madison, NE 68748		dwb, inc. PO Box 626 Madison, NE 68748
--	--	--

WHEREAS THE UNDERSIGNED has provided materials or services for the above project under an agreement with the Owner or the Contractor, the Undersigned does hereby waive and release all bond claims, liens, or claims or right of lien, statutory or otherwise, against the property, project, Owner and any sureties for labor, services, materials or equipment, as provided by the Undersigned, but only to the extent of payment received.

	Original Contract amount	Net change by C.O.	Amount of Contract as of the date of this lien waiver	Amount acknowledged as received by this partial waiver & release of lien	Total amount acknowledged as received to date
1. Gym/Lock	3,592,191.00	\$59,811.18	3,652,002.18	\$185,623.97	\$3,017,257.06
2. Mezz/Comm	1,678,133.00	\$57,114.74	1,735,247.74	\$45,468.42	\$1,581,318.42
3. Fire Sprinkle	107,358.00	(\$10,120.00)	\$97,238.00	\$16,863.45	\$ 90,518.61
4. Bus Drop	342,302.00		342,302.00	\$ 97,487.10	\$184,607.80

THE PERSON SIGNING below does hereby certify that he or she is fully authorized and empowered to execute this instrument and to bind the Undersigned hereto, and does in fact so execute this instrument.

Company Name: dwb, inc

Address: PO Box 626, Madison, NE 68748

Signed:  _____

Date: 7/30/2020 _____

Title: President _____

Madison High School Phase IV 700 S Kent St Madison, NE 68748	White Castle Roofing PO Box 22133 Lincoln, NE 68542	dwb, inc. PO Box 626 Madison, NE 68748
--	---	--

PROJECT
SUBCONTRACTOR/
SUPPLIER
CONTRACTOR
Date: 07 29 /2020

PARTIAL WAIVER & RELEASE OF LIEN

WHEREAS THE UNDERSIGNED has provided materials or services for the above project under an agreement with the Owner or the Contractor, the Undersigned does hereby waive and release all bond claims, liens, or claims or right of lien, statutory or otherwise, against the property, project, Owner and any sureties for labor, services, materials or equipment, as provided by the Undersigned, but only to the extent of payment received.

THE PERSON SIGNING below does hereby certify that he or she is fully authorized and empowered to execute this instrument and to bind the Undersigned hereto, and does in fact so execute this instrument.

Company Name: White Castle Roofing
Signed: [Signature]
Title: president

Project	Original Contract amount	Net change by C.O.	Amount of Contract as of the date of this lien waiver	Amount acknowledged as received by this partial waiver & release of lien	Total amount acknowledged as received to date
1. Gym	\$273,132.00	\$2,704.00	\$276,654.33	\$	\$217,526.66
2. Mezz	\$187,666.00	(\$818.33IH) \$2,705.00 (\$769.14IH)	\$191,140.14	\$4,841.06	\$162,638.11

PARTIAL WAIVER & RELEASE OF LIEN

PROJECT	SUBCONTRACTOR/ SUPPLIER	CONTRACTOR
Madison High School Phase IV 700 S Kent St Madison, NE 68748	Volkman Plumbing & Heating 211 South 3rd St Norfolk, NE 68701	dwb, inc. PO Box 626 Madison, NE 68748

WHEREAS THE UNDERSIGNED has provided materials or services for the above project under an agreement with the Owner or the Contractor, the Undersigned does hereby waive and release all bond claims, liens, or claims or right of lien, statutory or otherwise, against the property, project, Owner and any sureties for labor, services, materials or equipment, as provided by the Undersigned, but only to the extent of payment received.

Pay App	Original Contract amount	Net change by C.O.	Amount of Contract as of the date of this lien waiver	Amount acknowledged as received by this partial waiver & release of lien	Total amount acknowledged as received to date
1. Gym/Locker	\$553,594.00	-(-\$10,500.00)	\$543,094.00	\$67,696.05	\$239,678.88
2. Mezz/Comm	373,053.00		373,053.00	\$	\$85,996.90

THE PERSON SIGNING below does hereby certify that he or she is fully authorized and empowered to execute this instrument and to bind the Undersigned hereto, and does in fact so execute this instrument.

Company Name: **Volkman Plumbing & Heating**

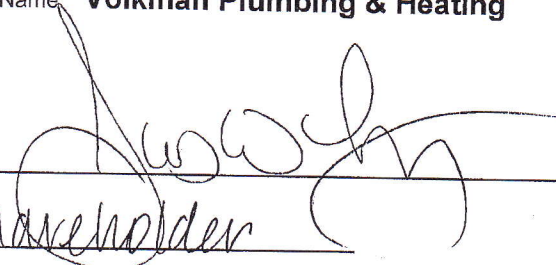
Signed: 
 Title: Shareholder

Date: 7, 29 / 2020

PARTIAL WAIVER & RELEASE OF LIEN

PROJECT	SUBCONTRACTOR/ SUPPLIER	CONTRACTOR
Madison High School Phase IV 700 S Kent St Madison, NE 68748	Elite Door 1804 W Omaha Ave Norfolk, NE 68701	dwb, inc. PO Box 626 Madison, NE 68748

WHEREAS THE UNDERSIGNED has provided materials or services for the above project under an agreement with the Owner or the Contractor, the Undersigned does hereby waive and release all bond claims, liens, or claims or right of lien, statutory or otherwise, against the property, project, Owner and any sureties for labor, services, materials or equipment, as provided by the Undersigned, but only to the extent of payment received.

Project	Original Contract amount	Net change by C.O.	Amount of Contract as of the date of this lien waiver	Amount acknowledged as received by this partial waiver & release of lien	Total amount acknowledged as received to date
1. Gym/Locker	\$ 3,551.00	-	\$ 3,551.00	\$2,698.00	\$3,408.20
2. Mezz	\$6,901.00		\$6,901.00	\$5,605.80	\$5,605.80

THE PERSON SIGNING below does hereby certify that he or she is fully authorized and empowered to execute this instrument and to bind the Undersigned hereto, and does in fact so execute this instrument.

Company Name: **Elite Door**

Signed: 

Date: 7 / 28 / 2020

Title: Manager

PARTIAL WAIVER & RELEASE OF LIEN

PROJECT	SUBCONTRACTOR/ SUPPLIER	CONTRACTOR
Madison High School Phase IV 700 S Kent St Madison, NE 68748	Meininger Fire Protection PO Box 85535 Lincoln, NE 68501	dwb, inc. PO Box 626 Madison, NE 68748

WHEREAS THE UNDERSIGNED has provided materials or services for the above project under an agreement with the Owner or the Contractor, the Undersigned does hereby waive and release all bond claims, liens, or claims or right of lien, statutory or otherwise, against the property, project, Owner and any sureties for labor, services, materials or equipment, as provided by the Undersigned, but only to the extent of payment received.

Project #	Original Contract amount	Net change by C.O.	Amount of Contract as of the date of this lien waiver	Amount acknowledged as received by this partial waiver & release of lien	Total amount acknowledged as received to date
1. Gym/Locker	\$ 22,791.00	-	\$ 22,791.00	\$	\$21,650.88
2. Mezz/Comm	\$ 16,106.00		\$16,106.00	\$	\$15,300.69
3. Fire Sprinkle	\$ 102,103.00	-\$10,102.00	\$ 92,001.00	\$15,080.29	\$92,244.75

THE PERSON SIGNING below does hereby certify that he or she is fully authorized and empowered to execute this instrument and to bind the Undersigned hereto, and does in fact so execute this instrument.

Company Name: **Meininger Fire Protection**

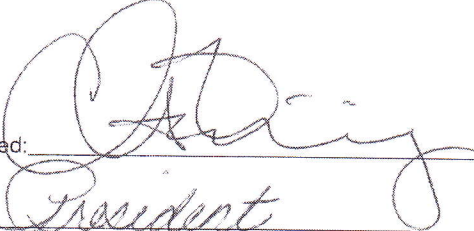
Signed: 
 Title: President

Date: 07.28/2020

PARTIAL WAIVER & RELEASE OF LIEN

PROJECT	SUBCONTRACTOR/ SUPPLIER	CONTRACTOR
Madison High School Phase IV 700 S Kent St Madison, NE 68748	Complete Floors 1019 Monroe Ave Norfolk, NE 68701	dwb, inc. PO Box 626 Madison, NE 68748

WHEREAS THE UNDERSIGNED has provided materials or services for the above project under an agreement with the Owner or the Contractor, the Undersigned does hereby waive and release all bond claims, liens, or claims or right of lien, statutory or otherwise, against the property, project, Owner and any sureties for labor, services, materials or equipment, as provided by the Undersigned, but only to the extent of payment received.

Date	Original Contract amount	Net change by C.O.	Amount of Contract as of the date of this lien waiver	Amount acknowledged as received by this partial waiver & release of lien	Total amount acknowledged as received to date
1. Gym	\$ 21,637.00	\$8,121.00	\$ 29,758.00	\$3,679.26	\$26,178.69
2. Mezz	\$ 41,715.00	\$1,963.00	\$ 43,678.00	\$9,119.20	\$40,188.71

THE PERSON SIGNING below does hereby certify that he or she is fully authorized and empowered to execute this instrument and to bind the Undersigned hereto, and does in fact so execute this instrument.

Company Name: **Complete Floors**

Signed: _____

Date: 7/28/2020

Title: _____

PARTIAL WAIVER & RELEASE OF LIEN

PROJECT	SUBCONTRACTOR/ SUPPLIER	CONTRACTOR
Madison High School Phase IV 700 S Kent St Madison, NE 68748	Carroll Seating 285 18th St, SE, STE D Owatonna, MN 55060	dwb, inc. PO Box 626 Madison, NE 68748

WHEREAS THE UNDERSIGNED has provided materials or services for the above project under an agreement with the Owner or the Contractor, the Undersigned does hereby waive and release all bond claims, liens, or claims or right of lien, statutory or otherwise, against the property, project, Owner and any sureties for labor, services, materials or equipment, as provided by the Undersigned, but only to the extent of payment received.

Project	Original Contract amount	Net change by C.O.	Amount of Contract as of the date of this lien waiver	Amount acknowledged as received by this partial waiver & release of lien	Total amount acknowledged as received to date
I. Gym	\$ 36,122.00	-	\$ 36,122.00	\$3,800.00	\$34,315.92

THE PERSON SIGNING below does hereby certify that he or she is fully authorized and empowered to execute this instrument and to bind the Undersigned hereto, and does in fact so execute this instrument.

Company Name: **Carroll Seating**

Signed: 
 Title: President

Date: 7/28/2020

PARTIAL WAIVER & RELEASE OF LIEN

PROJECT	SUBCONTRACTOR/ SUPPLIER	CONTRACTOR
Madison High School Phase IV 700 S Kent St Madison, NE 68748	Wragge Construction PO Box 584 Plainview, NE 68769	dwb, inc. PO Box 626 Madison, NE 68748

WHEREAS THE UNDERSIGNED has provided materials or services for the above project under an agreement with the Owner or the Contractor, the Undersigned does hereby waive and release all bond claims, liens, or claims or right of lien, statutory or otherwise, against the property, project, Owner and any sureties for labor, services, materials or equipment, as provided by the Undersigned, but only to the extent of payment received.

Project	Original Contract amount	Net change by C.O.	Amount of Contract as of the date of this lien waiver	Amount acknowledged as received by this partial waiver & release of lien	Total amount acknowledged as received to date
1. Gym	\$98,770.00	\$2,774.00	\$101,544.00	\$	\$41,296.50
2. Mezz	\$34,867.00	\$455.00-	\$35,322.00	\$	\$31,963.70
4. Site Paving	\$138,405.00		\$138,405.00	\$20,388.90	\$74,083.85

THE PERSON SIGNING below does hereby certify that he or she is fully authorized and empowered to execute this instrument and to bind the Undersigned hereto, and does in fact so execute this instrument.

Company Name: **Wragge Construction**

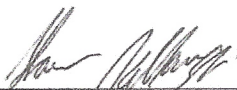
Signed: 

Date: 8/2/2020

Title: President

PARTIAL WAIVER & RELEASE OF LIEN

PROJECT	SUBCONTRACTOR/ SUPPLIER	CONTRACTOR
Madison High School Phase IV 700 S Kent St Madison, NE 68748	Storage & Design Group 5600 Metro East Dr Des Moines, IA 50327	dwb, inc. PO Box 626 Madison, NE 68748

WHEREAS THE UNDERSIGNED has provided materials or services for the above project under an agreement with the Owner or the Contractor, the Undersigned does hereby waive and release all bond claims, liens, or claims or right of lien, statutory or otherwise, against the property, project, Owner and any sureties for labor, services, materials or equipment, as provided by the Undersigned, but only to the extent of payment received.

Date	Original Contract amount	Net change by C.O.	Amount of Contract as of the date of this lien waiver	Amount acknowledged as received by this partial waiver & release of lien	Total amount acknowledged as received to date
1.Gym/Lockers	\$18,500.00	-	\$18,500.00	\$3,135.00	\$18,335.00

THE PERSON SIGNING below does hereby certify that he or she is fully authorized and empowered to execute this instrument and to bind the Undersigned hereto, and does in fact so execute this instrument.

Company Name: **Storage & Design Group**

Signed: Craig Dittmer

Date: 8 / 3 / 2020

Title: project manager

Madison Public Schools

Alan Ehlers
Superintendent

Jim Crilly
HS Principal
Reid Ehrisman
MS Principal/EL

Karla Kush
Elementary Principal

700 So Kent St.
P.O. Box 450
Madison, NE 68748
District Phone (402) 454-3336 Fax (402) 454-2238
Elementary Phone (402) 454-2656 Fax (402) 454-3978

Travis Jordan
Director of CAI
Crystal Ernst
Instructional Coach
Landon Mackey
Athletic Director
Celine Filsinger
Office Manager

The mission of Madison Public Schools is to prepare students to be competent, confident, productive, and responsible citizens.

Mrs. Ernst's August Board Report

- **Teacher Workdays Professional Development**
 - Instructional Coaching and Marzano Overview: This will give me the opportunity to go through the structure of instructional coaching for 1st semester, and begin the process of goal setting with all staff. Continuing to use the work previously done by the staff in regards to the Marzano framework, we will be focusing on the first two levels of Marzano elements.
 - Marzano Vocabulary: Review the process of teaching vocabulary using Marzano's 6-step process.
- **School Improvement**
 - The School Improvement team will meet Friday, August 7th and begin to prepare our plan for this cycle (our next accreditation visit is 20204). Our first priority will be to address the recommendations from the previous visit.
- **Instructional Coaching**
 - Teachers will be scheduling times in the first weeks of school to meet and develop their professional goals and choose strategies.
 - A schedule is being developed for supporting first and second year teachers. My goal is to help teachers plan several times a week and then visit classrooms throughout the week.

Madison Public Schools

Alan Ehlers
Superintendent

Jim Crilly
HS Principal
Reid Ehrisman
MS Principal/EL

Karla Kush
Elementary Principal

700 So Kent St.
P.O. Box 450
Madison, NE 68748
District Phone (402) 454-3336 Fax (402) 454-2238
Elementary Phone (402) 454-2656 Fax (402) 454-3978

Travis Jordan
Director of CAI
Crystal Ernst
Instructional Coach
Landon Mackey
Athletic Director
Celine Filsinger
Office Manager

The mission of Madison Public Schools is to prepare students to be competent, confident, productive, and responsible citizens.

Mrs. Kush – August 5, 2020
Elementary Principal

Number of Students in Elementary School

Grade Level	Current as of 8/5/20
PreK-3	18
PreK-4	32
Kindergarten	36
1 st Grade	43
2 nd Grade	40
3 rd Grade	31
4 th Grade	34
5 th Grade	36
Total	270
	Last year ended with 287

Student Report

	Last Year	2020- 2021 Goal
Attendance	95.59%	96%

1. Enrollment numbers will change because this report was created on the first day of registration days.
2. Attendance is something that is tracked often. Tracking chronic absence is a strategy to promote literacy development (Annie E. Casey Foundation, 2016). And with the state's push to have students reading at grade level by the end of their 3rd grade year, I know getting students to school is a priority. Also, the realization of attendance being lower this year needs to be understood due to the Covid-19 pandemic. So, the goal may be unrealistic this school year.
3. We are so excited to start the Little Dragons Child Care at the elementary building this year! What a great way to support our families – both the staff's and the community's.
4. Madison Elementary School has been approved to join the network of family literacy sites via the Statewide Family Engagement Center (SFEC) grant through

National Center for Families Learning (NCFL). We are very excited to implement family literacy programming within the school district. (see attached SFEC letter)
-We have held the implementation training and are working on recruitment of families.

5. Jump Start was held July 27-August 4, 2020. The After-School Program was offered for up to 40 students (due to Covid-19) and 25 total registered.

Number of Students Attending Jump Start							
July 27	July 28	July 29	July 30	July 31	Aug. 3	Aug. 4	Average
41	53	54	50	50	43	39	47

-2019-2020's Average was 54.4 students.

-It was hard to know what to expect at Jump Start this year, but it wasn't a whole lot lower. It was also good way to see how things will work for the upcoming school year.

-Overall, it was so great having students back in the building again.

6. The 2020-2021 school year is a new experience for everyone because of the pandemic. Madison Elementary has been working to make a safe environment for students to keep everyone healthy. Some of the key components include: temperature checks upon entering the building and bus, frequently washing hands, spacing students out in different areas for breakfast and at the beginning of the school day, changing lunch times to limit the number of students in the cafeteria, seating arrangements within the classroom, recommending masks, hallway movement, and water fountains being closed. Communication between families and the school is going to be more important than ever to move past these challenging times. But, I am confident that it is only making us stronger and more effective.

Madison Public Schools

Alan Ehlers
Superintendent

Jim Crilly
HS Principal
Reid Ehrisman
MS Principal/EL

Karla Kush
Elementary Principal

700 So Kent St.
P.O. Box 450
Madison, NE 68748
District Phone (402) 454-3336 Fax (402) 454-2238
Elementary Phone (402) 454-2656 Fax (402) 454-3978

Travis Jordan
Director of CAI
Crystal Ernst
Instructional Coach
Landonn Mackey
Athletic Director
Celine Filsinger
Office Manager

The mission of Madison Public Schools is to prepare students to be competent, confident, productive, and responsible citizens.

August 2020 Board Report- Jim Crilly High School Principal

Enrollment

9th 40 Students

10th 36 Students

11th 340 Students

12th 44 Students

Total Enrollment- 160 Students

Will have new numbers after HS registration is complete.

- High School Registration will take place August 5th and 6th.
- First Day of School is August 12th with a 1:00 Dismissal, first full day August 13th
- Computer check out for HS will take place this year over registration days if all fees and paperwork are completed.
- 2020-2021 HS Schedule is complete, some of these assignments may change after registration.
- 4 New High School teachers have all been assigned a seasoned veteran teacher as a mentor this year.
- Special thanks to the custodial staff with their hard work this summer.

Madison Public Schools

Alan Ehlers
Superintendent

Jim Crilly
HS Principal
Reid Ehrisman
MS Principal/EL

Karla Kush
Elementary Principal

700 So Kent St.
P.O. Box 450
Madison, NE 68748
District Phone (402) 454-3336 Fax (402) 454-2238
Elementary Phone (402) 454-2656 Fax (402) 454-3978

Travis Jordan
Director of CAI
Crystal Ernst
Instructional Coach
Landonn Mackey
Athletic Director
Celine Filsinger
Office Manager

The mission of Madison Public Schools is to prepare students to be competent, confident, productive, and responsible citizens.

Mr. Ehrisman- August 4, 2020
MS Principal, IPM (Intervention Project Manager), EL Coordinator

Grade Level	Current as of 8/4/20		Start of Year 8/7/19	End of year 5/6/20
6th Grade	41		43	44
7th Grade	44		27	26
8th Grade	26		39	41
MS Total	111		109	111

- The MS applied and received \$296,659 for year three of the SFI grant. In addition to this, we also have an estimated \$75,000 of remaining in year two funds. These funds have been sent to NDE in hopes to designate for the following:
 - Portion of MS principal and Instructional Coach salary
 - Ron Clark PD
 - Para salary
 - Cornerstones of Care (BIST) and Midtown Health
 - Science Curriculum
 - iPads
 - EL teacher salary
 - WiFi Hot Spots
- House T-shirts for the 20-21 school year have been ordered! Thanks to our generous donors that made this possible: Tyson, Reigle Implement, Deet's Furniture, Albracht Disposal, Weiland Inc., Kyle Knapp, Trans Inc., Brady & Amy's, John and Jeanne Reigle, Pinnacle Bank, Connie's Quilts, Pfeifer Autobody, Madison Veterinary Clinic
- MS teacher schedules and rosters are finalized.
- We will continue the AMP program for the 20-21 school year. It will support students that have below a 70% in a class or needing a set time to work on assignments.

Madison Public Schools

Alan Ehlers
Superintendent

Jim Crilly
HS Principal
Reid Ehrisman
MS Principal/EL

Karla Kush
Elementary Principal

700 So Kent St.
P.O. Box 450
Madison, NE 68748
District Phone (402) 454-3336 Fax (402) 454-2238
Elementary Phone (402) 454-2656 Fax (402) 454-3978

Travis Jordan
Director of CAI
Crystal Ernst
Instructional Coach
Landonn Mackey
Athletic Director
Celine Filsinger
Office Manager

The mission of Madison Public Schools is to prepare students to be competent, confident, productive, and responsible citizens.

Curriculum, Instruction, and Assessment

August 2020, Board Report

Curriculum:

- Our Middle School Language Arts and SPED teachers had 3 days of P.D. for our new Into Literature Program
- In year 2 of Wonders at the Elementary, we are adding the Grammar portion of the program in all grades K-5.
- We are going to begin the process of exploring Middle School Science Curriculum to meet Nebraska's College and Career Ready Standards per Mr. Ehrisman's request.

Instruction:

- We have all K-12 staff trained in Canvas. In the event that we move to distance learning again, all Students will be on the same platform to make life easier for Parents as well as our Tech Dept.
- Several of our Elementary teachers attended Wonders Templates training. They were very excited with what they picked up and are going to work with their grade level peers to make sure we are using best practices.

Assessment:

- The plan right now is to get all of our K-8 Students tested in Acadience (DIBELS Next) by the 3rd week of School so we can get all of our kids placed in Interventions if needed.
- I am setting up a Schedule for MAP testing that will take place upon a return after Labor Day.
- ACT Prep is a bigger focus for our district this year. We have a plan in place and some dates blocked out. Once we are back in school, Mr. Crilly, Mrs. Kunz, and I will be meeting to finalize our plan.

Madison Public Schools

Alan Ehlers
Superintendent

Jim Crilly
HS Principal

Reid Ehrisman
MS Principal/EL

Karla Kush
Elementary Principal

700 So Kent St.

P.O. Box 450

Madison, NE 68748

District Phone (402) 454-3336 Fax (402) 454-2238

Elementary Phone (402) 454-2656 Fax (402) 454-3978

Travis Jordan

Director of CAI

Crystal Ernst

Instructional Coach

Landon Mackey

Athletic Director

Celine Filsinger

Office Manager

The mission of Madison Public Schools is to prepare students to be competent, confident, productive, and responsible citizens.

August 2020 Board Report Landon Mackey, Athletic Director

- Fall sports (volleyball, football, and cross country) practices will begin on Monday, August 10th.
- First competitions:
 - Volleyball 8/24 @ Elba (Jamboree)
 - Football 8/28 vs. Lutheran High Northeast
 - Cross Country 9/3 @ Wisner-Pilger Invitational
- NSAA approved the start of fall practice on August 10th and will provide updated guidelines as the school year starts.
- Big Country—Drive for Your School Fundraiser—Cancelled in 2020 due to COVID.
- Attended the 2020 NDE Administrators' Days Conference July 29th-July 31st (Virtually).
Here are the sessions I attended:
 - Lay A Foundation for Success: Monitoring & Addressing Student Absenteeism
 - Discussed the importance of good attendance as it relates to student success and opportunities by developing positive relationships.
 - Recruitment and Retention of Students in CTE
 - Focus on the transition of students to postsecondary options and careers and how to adjust to meet student needs.
 - Nebraska Teacher & Principal Performance Standards
 - Provided an overview of the new performance standards and how to align standards to instructional models.
 - Educator Effectiveness
 - Focus on making data driven decisions and equity with performance standards and evaluation rubrics.
- Nebraska Coaches Association clinic in Lincoln was cancelled due to COVID-19. Individual coaches meetings were held to goal plan and collaborate on the needs of each program.
- Each fall sports coach will have to take the Head, Heart and Heat certification courses required through the NSAA and NFHS.
- Head coaches meeting planned for August 7th.
- East Husker Conference will be virtual this year with Zoom meetings set up by host schools. Head coaches and myself will attend those meetings.
- All medals have been purchased for home wrestling and track meets.
- Big Red Kickoff will be Thursday, August 20th starting at 6:15 in the MS/HS gym (new gym). Popcorn and pop/water will be served. This will be followed by band, cheer, dance, introduction of MPS staff members, building dedication & chamber ribbon cutting, and athletic coaches/teams.
- Estimated participation numbers for fall sports: Volleyball—20, Football--27, Cross Country—12 (9 boys & 3 girls).

- High School Fall Coaches:
 - Volleyball—Nicole Unkel, Chris Miller, Pagie Holub
 - Football—Joe Crilly, Collin Crilly, Shane Prather, Jim Crilly
 - Cross Country—Connie Herz, Casey Wolta
- Weight room average daily attendance was 15 boys and 22 girls for June and July. Low numbers can be assumed with COVID-19. Coaches and myself will evaluate and brainstorm to improve weight room attendance for summer 2021.





2020 NSAA Fall Season Guidelines

Circumstances related to the COVID-19 pandemic are constantly changing and the circumstances vary from community to community. Difficult decisions will have to be made from week to week or even day to day. The safety and well-being of the participants and spectators is and always will be the primary consideration as we provide opportunities to participate in the fall sports season.

Each school has the authority to determine if it will participate in the 2020 Fall Season. During the season it will be the responsibility of the host school to provide administrative oversight in compliance with established COVID-19 guidelines in accordance with their local health departments and facilities. **Prior to any contest, the host school administration will be required to notify the visiting school administration of their established protocols.** The visiting team and spectators will be expected to adhere to all protocols established by the host school.

The host school should make every effort to mitigate risk and provide adequate opportunities for physical distancing procedures for the opposing team, officials, and all spectators.

This may include but is not limited to:

- Restricting attendance / seating areas
- Separate points of entry for home and visitor teams / spectators
- No concession stands or separate/multiple concession stands for home and visitor spectators
- Separate / multiple restrooms for home and visitor spectators
- Adequate locker room space / outdoor space for the opposing team
- Adequate locker room space / outdoor space for the officials
- Encouraging / requiring spectators to wear face coverings
- Implementing diligent and effective cleaning and disinfecting of frequently touched objects and surfaces

If a school has a player test positive for COVID-19, they will contact their County Health Department regarding a course of action.

It is recommended that players, coaches, and spectators have their temperatures checked at home or at the school prior to participating in or attending practices and games. Any individual with a temperature of 100.4 or above should not participate in or attend practices or games.

During practice, coaches should make accommodations for physical distancing whenever possible. Provide adequate spacing when participating in stretching, instructional time and drills. Conduct workouts in small groups whenever possible.

During competition, the sideline/bench/team areas should be restricted to essential personnel only. This includes players, coaches, team trainers, team managers, game officials, statisticians, and media.

Coaches, officials, and players should be cognizant of physical distancing guidelines when interacting during the game.

Pregame and postgame interactions between opposing coaches and players should adhere to physical distancing guidelines.

Schools are encouraged to play their regularly scheduled competitions unless a COVID-19 issue prevents them from playing. Member schools shall be solely responsible for determining whether a scheduled game, match, contest, or other activity is cancelled or postponed due to a COVID-19 related issue in consultation with their local health departments. Member schools shall notify the NSAA of any cancellation or postponement.



2020 NSAA Football COVID-19 MODIFICATIONS

NSAA APPROVED RULINGS

- Practice may begin on Monday, August 10th
 - First contests may begin on Thursday, August 27th
- Schools with week zero games may begin practice on Wednesday, August 5th
 - Games will be played on Friday, August 21st
- Adjustments to the regular season and post season will be considered and implemented if deemed necessary.
- Schools will notify the NSAA of any game cancellations within twenty-four hours of the decision.
- Schools are solely responsible for determining whether a scheduled game is cancelled due to a COVID-19 related issue in consultation with their local health departments.
- The NSAA will maintain an up-to-date list of schools with open dates and replacement games on the NSAA website.
- Regularly scheduled games cancelled due to COVID-19 related issues will be counted as a “No-Contest”
 - Forfeits will not be issued
 - Wildcard points will not be awarded
- Schools have the authority to schedule a replacement game if another school is available
 - Only the results of regularly scheduled games scheduled prior to the start of the season will be used to calculate wildcard points

NFHS GAME PROTOCOLS

- Schools are encouraged to use 5-man officiating crews whenever possible at regularly scheduled varsity games. If a 5-man crew is not available, the game may be played with any number of officials upon mutual agreement of the opposing coaches. All regularly scheduled varsity games must use NSAA registered officials.
- If a replacement game is scheduled, any number of officials may be used upon mutual agreement of the opposing coaches. The use of NSAA registered officials is recommended. The use of non-registered officials is permitted.
- Players, coaches, officials, and all game administration should sanitize their hands before, during and after the game
- Face coverings are permissible for officials, coaches, players, staff, and game administration
- Team box may be extended to the 10-yard line (PLAYERS ONLY)
- Players should maintain physical distancing on the sideline whenever possible
- Players should not share towels, water bottles or other equipment
- The ball should be cleaned/sanitized periodically throughout the contest
- Plastic shields covering the entire face are prohibited
- “Splash Guards” that are integrated into the face mask, attached to the helmet and are completely clear are permitted
- A single charged time-out may be extended to a maximum of two minutes
- The authorized conference for the charged time-out should take place between the 9-yard marks and not at the sideline for physical distancing purposes. More than one coach is allowed in the conference and technology can be used.
- Intermission may be extended to a maximum of two minutes:
 - Between the first and second periods
 - Between the third and fourth periods
 - Following a PAT, successful field goal or safety prior to the succeeding free kick
- Electronic whistles are permitted but not mandatory
- Pregame Responsibilities and Coin Toss
 - Coin Toss
 - Limit participants to the Referee, Umpire and one designee from each team
 - Move to an area to maintain physical distance
 - Maintain physical distance while performing all pregame duties and when communicating with crew members, coaches, players, game administration, chain crew, clock operators and ball holders
- Postgame
 - No shaking hands



2020 NSAA Volleyball COVID-19 Modifications

NSAA Approved Rulings:

1. Extend the deadline to submit varsity schedules to the NSAA from August 21st to August 27th.
2. Matches canceled due to COVID-19 will be considered a “no contest.”
 - a. Wild card points will not be awarded for “no contest” matches.
 - b. Forfeits will not be issued for “no contest” matches.
3. Replacement matches (not originally scheduled) may be scheduled at any time.
 - a. Wild card points will not be awarded.
 - b. Contest limits/competition points may not be exceeded.

NFHS Match Protocols:

1. Face coverings are permissible for athletes, coaches, officials, game administration, and spectators.
2. Officials are permitted to use electronic whistles.
3. Score table is limited to essential personnel only.
 - a. Scorekeeper, clock operator, libero tracker, announcer if using
 - b. Maintain social distancing
4. Pre- match and post-match handshake protocols are prohibited.
5. Not switching team benches/courts between sets is permissible.



2020 NSAA Softball COVID-19 Rules Modifications & Considerations

- All NSAA member schools must follow their local [Directed Health Measures](#).
- Schools that are in Phase 3 must follow the [DHHS Sports Reopening Guidelines](#) and it is recommended that schools in Phase 4 do the same to create continuity and consistency.
- The host administration must pre-communicate local protocols and activity requirements to participating school(s).

NSAA Approved Rulings:

Schedules

1. The deadline to submit varsity schedules to the NSAA has been extended to August 20th.
2. Regular season games that are canceled due to COVID-19 will be considered a “no-contest.”
 - a. Wild card points will not be awarded for “no-contest” games.
 - b. Forfeits will not be issued for “no-contest” games.
3. Replacement games (not originally scheduled) may be scheduled at any time.
 - a. Wild card points will not be awarded.
 - b. Contest limitations may not be exceeded.

NFHS Softball Rules Modifications:

Face Shields (1-7-1, 1-8-4) - Per guidance from the NFHS Sports Medicine Advisory Committee, plastic shields covering the entire face (**unless integrated into the face mask and attached to a helmet and clear without the presence of any tint**) shall not be allowed during contests. Their use during practices increases the risk of unintended injury to the person wearing the shield or to teammates.

Facial Coverings/Additional Equipment (1-8): Cloth facial coverings are recommended but not required. Facial coverings must be of one color, not distracting and have no designs. Pitchers cannot wear optic yellow cloth facial coverings.

Pregame Conference (2-14-2): Limit attendees to one coach from each team plus the umpires. Coaches should stay outside the width of the batter’s box at home plate, maintaining 6 feet of distance between each person.

Substitutions: (3-3-3): The verbal exchange should occur 6 feet from the coach to scorer and opposing team when making lineup changes.

Foul Balls/Coaching (3-5-1 NOTE): Umpires do not handle equipment on the field during play.

Contact with the game balls should be as limited as possible. During competition, foul balls should be retrieved by personnel from the defensive team. Simultaneously a new ball should be thrown into game play from the defensive team's dugout.

Coaching (3-5-3, 3-6-14): Coaches who wish to discuss a rule or a ruling on the field must maintain at least 6 feet of distance from the umpire.

Coaching (3-5-2): Base coaches must stay 6 feet from a runner at all times after suspension of play.

Bench and Field Conduct (3-6-6): Players are not permitted to leave the dugout area to congratulate players when scoring or after home runs. The number of individuals in the dugout is dependent on the size of dugout. Players and coaches should maintain 6 feet of social distance. NFHS rules allow for dugouts/designated warm-up areas to be extended to provide for social distancing. The dugout extension should be outside of the field.

Charged Conferences (3-7-1, 3-7-2, 3-7-3): Coaches holding defensive conferences must stay on the home plate side of the pitcher's circle, and the player or players must be on the opposite side of the pitcher's circle maintaining 6 feet of distance. No more than two players plus the pitcher are allowed. Only one coach is permitted during the conference. If a coach visits the pitcher, all other players should stay outside the pitching circle.

Exchange of Lineup Cards (4-2-1b): Lineups should be handed to the umpire, and the umpire will verbally approve or ask any questions about the lineup. It is recommended that lineup cards be exchanged team to team and teams to scorekeeper to be shared via photo or text.

Infractions by the Pitcher (6-2-2): Pitchers are not allowed to put their hands to their mouths or blow into their hands prior to pitching the ball. This will be a "no pitch." Any umpire is permitted to make this call. The ball should be called dead immediately and it will be a "no pitch." The ball should be put in the dugout for cleaning, and the pitcher should sanitize hands before play continues.

Plate Umpire (10-2-1): The plate umpire should stand deeper than normal to call balls and strikes.

Equipment and Apparel (10-4-2): Cloth facial coverings are recommended but not required. The masks must be of one color, not distracting and have no designs. The umpire may wear disposable gloves and masks.

Softball Umpires Manual Modifications

Mechanics Sections 3, 4b and c: Base umpires should maintain 6 feet of distance from any player as a starting position when rotated and/or counter-rotated.

Section 2E: The catcher and batter should be 6 feet apart when the umpire is dusting off the plate.

Considerations for Umpires:

1. Consider facility size and spacing within umpire dressing rooms. They should be cleaned and sanitized.
2. If umpires must enter the field through the dugout, the dugout should be empty with no players/coaches/team personnel.

Further Softball Considerations:

1. Players should use their own equipment (e.g. gloves, helmets and bats) as much as possible.
2. Offensive helmets do not need to match.
3. Postgame shaking of hands is suspended.
4. Limit the number of non-essential personnel who are in the press box throughout games.
5. Coaches are responsible for ensuring social/physical distancing is maintained between players as much



2020 NSAA Cross Country COVID-19 Rules Modifications & Considerations

Areas of identified risk include start & finish areas. Below describes the possibility to help manage these risks:

Start

- Teams may be called to the start line 5 minutes prior to start to minimize duration in close proximity. Cross country meets could also consider using staggered, wave or interval starts when necessary.
- If possible provide an empty starting box of 6 feet between each team.

Finish

- Consider using finish corrals and FAT timing for larger meets as it is easier to distance at finish. Chip timing at championship meets eliminates any need for contact at the finish.
- With no FAT timing system consider alternative means of finish place and time to address congestion at finish line.
- Finish area should be designed structurally and with staff to keep finishers moving in a direction directly back to the team camps immediately.
- The area beyond the finish should be large enough to allow athletes to keep moving
- Consider using image-based equipment at finish to assist with picking place to avoid congestion.

Prerace and Postrace Ceremony

- Establish cross country specific social distancing meet protocols including the elimination of handshakes before and after.
- It is recommended to not have award ceremonies

Possible NFHS Rule Modifications:

- 8-1-3a: Consider widening the course to at least 6 feet at its narrowest point.

NSAA approved changes for 2020

Class A cross country districts will be at 2 sites for the 2020 season. The NSAA will follow the previous format to determine seeding for districts.



2020 NSAA Girls Golf COVID-19 Rules Modifications & Considerations

Equipment/Facility:

- Driving range is to be determined by golf course.
- Much of the facility information will come from the golf course.
- If bad weather occurs it is recommended that all should return to their vehicles rather than the clubhouse.
- It is recommended to not have award ceremonies.

Contest warm up:

- Driving range regulations determined by golf course.
- Consider having a rotation of use to limit number on the range at one time and putting green.

Competition:

- Communicate the details of the event prior to the day of the event. This way schools can plan their arrival and competition with minimal gatherings to discuss the event details.

Practice Areas - The policies below for the practice range and putting/chipping green(s) allows for players to practice prior to their start time on a limited basis. All players should have equal opportunity to practice before their round if the following are adhered to.

- **Practice Range**
 - Limitations to the number of players that may be on the range will be site specific based on the size of the range and the number of stations available using 6' social distancing.
 - Players only allowed on the practice range.
 - Players can be limited to only one bag of balls (approximately 50 balls) to hit on the range.
- **Putting/Chipping Greens**
 - Limitations to the number of players that may be on the practice putting green and/or chipping green will be site specific based on the size of the greens.
 - Players only allowed on or around the greens.
 - Players should be quick and efficient with their practice to ensure all players get time on the greens.

Starting Areas - Players should arrive at their assigned tee no more than 5 min before their assigned starting time.

- **Scoring** –
 - Digital scoring may be used when available.

- Scorecards should be distributed to each player. Scorecards will not be exchanged or require signatures.
- Upon completion of the round players will enter the designated scoring area to review and verify their scores verbally with the scoring official.

GOLF COURSE SET-UP & RULES OF GOLF MODIFICATIONS

- **Bunkers** - Limited number of bunker rakes could be available on the golf course.
 - Ball will be played as it lies in the bunker.
 - If a player feels their ball is in an abnormal ground condition they can ask for relief from a member of the Committee. If granted, the relief procedure will be followed as stated in the Rules of Golf.
- **Flagstick** - Attending and removal of flagsticks is permitted if allowed by the facility.
 - It is recommended that the player that removed the flagstick be the one to replace it.
- **Returned Scorecard** - A scorecard will be deemed returned when the player has verbally verified their hole-by-hole scores with their marker and the scoring official and left the designated scoring area.

NSAA Championships and District Contests.

- Scoring monitors will not be used at district and state championships.

NSAA Board approved changes

Schedules for Class A are now due August 20th.

Schools in Class A can replace a meet or tournament that is missed. Schools cannot exceed the individual contest limit. Meets or tournaments that are replacement meets or tournaments will not count towards an individual or team differential. Note: This does not refer to meets or tournaments that are rescheduled.



2020 NSAA Boys Tennis COVID-19 Modifications

NSAA MATCH MODIFICATIONS

- Face coverings are permissible for coaches, spectators, and athletes (when not playing a match)
- Pre-Match and post-match handshakes are prohibited
- Use new balls for each match when possible
- Players should use opposite sides of the court to change sides or stay on your side of court
- Remain apart from other players when taking a break
- Individuals should use the same bench for every break
- Leave the court as soon as reasonably possible

PRE & POST MATCH PROTOCOLS

- Wash your hands with a disinfectant soap and water (for 20 seconds or longer) or use a hand sanitizer if soap and water are not readily available, before going to the court.
- Consider having each player carry their own hand sanitizer in their bag
- Clean and wipe down your equipment, including racquets and water bottles. Do not share racquets or any other equipment such as wristbands, grips, hats, and towels.
- Use your racquet/foot to pick up balls and hit them to your opponent. Avoid using your hands to pick up the balls.
- If a ball from another court comes to you, send it back with a kick or with your racquet.
- Bring a full water bottle to avoid touching a tap or water fountain handle.
- Try to stay at least six feet apart from other players not on your team.
- Avoid touching court gates, fences, benches, etc. if you can.
- Each respective team should have a designated area for teammates not playing that allows for social distancing from other teams
- Do not use the locker room or changing area. Shower at home.

Madison Public Schools

Alan Ehlers
Superintendent

Jim Crilly
HS Principal
Reid Ehrisman
MS Principal/EL

Karla Kush
Elementary Principal

700 So Kent St.
P.O. Box 450
Madison, NE 68748
District Phone (402) 454-3336 Fax (402) 454-2238
Elementary Phone (402) 454-2656 Fax (402) 454-3978

Travis Jordan
Director of CAI
Crystal Ernst
Instructional Coach
Landon Mackey
Athletic Director
Celine Filsinger
Office Manager

The mission of Madison Public Schools is to prepare students to be competent, confident, productive, and responsible citizens.

Superintendent Report August 2020

- **Building Projects update:**

Elementary campus – Mrs. Kush is working with Denise on a rubber mulch/used tire grant. She is also planning to work with her parent group to fund raise for the replacement of the older wooden play structure. When they have a couple of ideas we will bring to the board.

Middle School/High School campus – The Middle School Commons and High School Gym will be open to walk through if you want to do so prior to the start of the meeting. We will have the majority of the punchlist items for the MS done prior to our meeting but still will have several items on the Gym/Lockerroom list as that area is not finish at this point.

Athletic Complex – The long jump pit is still unfinished at this point.

Deputy Fire Marshal - On Tuesday August 4th the Deputy Fire Marshal orally gave us the go ahead after reviewing the code issues that were his concerns. He shared that now you have one of the safest buildings in the area in regards to fire code regulations. Thanks for your commitment to our students and staff.

- **The School District Audit:** The annual visit is scheduled for the week of September 28th. Adam, who was the lead person the last two years has been assigned other duties.
- **Title IX:** With new federal law comes requirements. On the agenda you will find an action item to consider a new required policy dealing with Title IX.
- **Big Red Kickoff:** In the hope of helping keep COVID -19 under control, We are just planning to serve popcorn and pop and candy during our annual event. I will explain more during our meeting.
- **After School Program:** After looking at the number of staffing we normally have to work the After School Program (ASP) and trying to stay to to less than 20 students per staff member we would like to consider offering the ASP to

students in Grades K-2, and then offering homework/skill building work to students in grades 3-5 once a week.

I understand this might be great for all students and families but with suggested numbers of students in classrooms at one time plus our lack of ability to staff the ASP this approach seems worth a try at this time.

- **Bus Camera's:** I have reached out to check on the cost of adding cameras to our buses. I'm not a big fan of this approach but may be something to consider. I'm not sure if we will have prices prior to our meeting on Monday.
- **Mosanto Grant:** If you recall we felt like this grant was a long shot but I guess the work that was placed in the grant process by our team members is going to help bring this to life. To make this happen we will need some depreciation funds to get the area in the shop ready. I don't have all the details at this point and time but to receive the \$15,000 is a good feeling.
- **NSAA recommendations:** One of the suggestions to have concession stands is to offer two area's to help keep the visitor fans away from the home fans. Also that home fans and visiting fans use separate restrooms. I'm not sure how good an idea things like this are at this point. I think some people could see this as discrimination? I would like to gather your feedback on these type of things.
- **COVID-19 PPE items that were required:**

So the following items have been ordered:

- 120 Face shields for staff
- 500 washable masks for students
- 200 washable masks for staff
- 100 masks for instructional staff that your lips are visible
- 120 small desk sanitizer pump bottles - Custodians will refill as needed
- 500 Lanyard's for the Elem. students to attach to their masks
- We have requested for 5 washable masks per student from the ESU. Should arrive in the next couple of weeks.
- We have over 50 gallons on hand sanitizer from the state.
- 30 gallons of hand sanitizer from the Clearwater Dairy
- All but two classrooms have wall mount sanitizers in them and Troy has a supply to refill
- We have ordered 5 foggers/sprayers ordered to disinfect classrooms (Should be in soon)
- 75 containers of disinfecting wipes are coming from the orphan grain train to be used in Childcare - PK classrooms and Elem. as needed.
- Troy is working on getting spray bottles to have in each common area spaces for cleaning.
- 14 digital thermometers
- 2 temp scan machines - one per building
- Plexiglass dividers for the lunch rooms
- Plexiglass by each building entrance

- Plexiglass by the secretaries windows
- Looking to hire additional PT custodian to help clean at the Elementary School.



1001 General Policy Statement

The organization, management, and control of this school district is vested in its board of education ("board"). To guide the board and school district operations, and to assist it and its designees in carrying out duties, the board will establish, maintain, and amend a set of policies.

Written board policies serve the following purposes:

1. Formally articulating the board's goals and long-term objectives.
2. Providing district administrators and staff with guidance in making decisions that affect students, employees and patrons of the district.
3. Informing the public of the manner that the board and district will conduct its business and its relationships with staff, pupils, parents and patrons.

To avoid unnecessary rigidity, these policies are stated in general terms. With the exception of statutory requirements or instances when the specific application of a policy is essential to the long-term welfare of the district, these policies are intended to provide administrators with the flexibility to apply them to a wide range of situations.

The policies are not the only guidelines for district operations. Specific regulations, procedures, and practices also help guide and govern actions and decisions. They must be consistent with policies, but serve a different purpose.

Exceptional Circumstances

The board cannot foresee every situation that may arise, and circumstances will occur when these policies provide inadequate guidance. In such circumstances, the superintendent should use his or her best judgment, and communicate with the board about the situation as soon as is convenient.

Validity of Policies

Each policy and its provision should be interpreted so that it is valid under applicable law. If a court determines that a provision of a policy is invalid, such invalidity shall not affect the remaining provisions of that policy.

Adopted on: 12-14-15

Revised on: _____

Reviewed on: _____

1002
Creation, Amendment, and Distribution of Board of Education Policies

Each of these policies shall become the official policy of the school district when the board has approved it by majority vote of the members present at any lawfully convened meeting of the board.

It shall generally be the practice of the board to adopt or amend any policy after a single reading at any regular or special board meeting. However, the board may, in its discretion, review policies at multiple meetings prior to taking action.

Each policy shall bear the date when it was adopted, revised or reviewed.

The superintendent shall distribute copies of these policies to all members of the board, maintain a master copy in the central office, and see to it that the policies are maintained on the school district's web site.

Annual Review

The board shall review all policies at least once every three years. Nebraska statutes require an annual review and/or hearing to solicit public comment on these specific policies:

Parental Involvement Policy

Title I Parental Involvement Policy

(NOTE: These first two are distinct parental involvement policies, and both must be reviewed annually.)

Student Fees Policy

Bullying

Multicultural Education

Student Assessment

Teacher Evaluation

Student Academic Performance

Safety and Security Committee

Attendance and Excessive Absenteeism

The board may update or add policies as needed. The board shall determine the number of copies of policies to be made and their distribution. The superintendent shall maintain an up-to-date master copy of the policies in the main administrative office. Unless otherwise directed by the board, the master copy shall be considered the official district policy manual.

Adopted on: 12-14-15

Revised on: _____

Reviewed on: _____

1003
Mission Statement

The mission of Madison Public Schools is to prepare students to be competent, confident, productive, and responsible citizens.

Adopted on: 12-14-15

Revised on: _____

Reviewed on: _____

**MADISON PUBLIC SCHOOLS
GENERAL FUND LEVY 2020-21**

	2019-20	2020-21	Change
Valuation	784,866,202	765,000,000	-2.53%
Total Valuation	784,866,202	765,000,000	-2.53%
General Fund Budget	9,025,000.00	9,275,000.00	\$250,000
Necessary Cash Reserve	200,000.00	200,000.00	
Total Requirements	9,225,000.00	9,475,000.00	
Beginning Balance - Cash on Hand	2,300,178.00	2,400,000.00	
Projected Income Before Taxes	1,412,000.00	1,500,000.00	
Madison County Tax Request	5,512,822.00	5,575,000.00	\$30,283
1% County Treasurer's Fee	55,990.90	55,990.00	
Deliquent Tax Allowance	0.00	0.00	
Total Tax Request	5,568,812.90	5,630,990.00	1.12%
Estimated Levy	0.709524	0.736077	0.026553
SPECIAL BUILDING FUND			
Tax Request	937,500.00	910,000.00	Split Lease Payment \$730,0 Reduced by \$27,870
1% County Treasurer's Fee	9,470.00	9,100.00	
Total Request	946,970.00	919,100.00	
Valuation	784,866,202	765,000,000	
Estimated SBF Levy	0.120654	0.120144	
Levy w/ Exclusions	0.830178	0.856221	0.026043
Bond Fund			
Qualified Capital Purpose Fund			
Tax Request	332,000.00	332,000.00	
1% County Treasurer's Fee	3,354.00	3,354.00	
1% County Treasurer's Fee	335,354.00	335,354.00	
Valuation	784,866,202	765,000,000	
Estimated Bond Levy	0.042728	0.043837	
Levy w/ Exclusions	0.872905	0.900058	0.027153

Based on this example we would ask for \$36,144.68 in taxes than we did in the 2019-20 School year.
The levy would increase to \$0.872866 which is about 2.5 cents

GENERAL FUND BUDGET SUMMARY

	Function	2019-20		2020-21	% Change
All Instruction Except Sped	1100	4,275,000.00		4,425,000.00	3.51%
Sped Instructional Programs	1200	830,000.00		830,000.00	0.00%
Support Services - Pupils	2100	390,000.00		390,000.00	0.00%
Support Services - Staff	2200	180,000.00		180,000.00	0.00%
Board of Education	2310	68,000.00		68,000.00	0.00%
Executive Admin.	2320	200,000.00		200,000.00	0.00%
Office of Principal	2400	475,000.00		500,000.00	5.26%
Business Services	2510	300,000.00		300,000.00	0.00%
Maint. & Operation Bldg.	2600	1,046,000.00		1,046,000.00	0.00%
Pupil Transportation	2750	128,000.00		128,000.00	0.00%
School Age Sped Trans.	2760	20,000.00		20,000.00	0.00%
State Programs		200,000.00		200,000.00	0.00%
Federal Programs	4000	850,000.00		900,000.00	5.88%
Transfers	8000	38,000.00		38,000.00	0.00%
Investment		0.00		0.00	#DIV/0!
Necessary Cash reserve		200,000.00		200,000.00	0.00%
Legal Services		25,000.00		25,000.00	0.00
TOTAL		9,225,000.00		9,450,000.00	2.44%
Actual Budget		9,025,000.00			

2020-21 budget example shows a \$250,000 General Fund Increase.
As you can see it would be a project 2.44% increase.

This increase is based on staff salary/ benefit increases
We added Instructional coach, Daycare & IT & AD.

Madison Public Schools

Alan Ehlers
Superintendent
Jim Crilly
HS Principal
Reid Ehrisman
MS Principal/EL
Karla Kush
Elementary Principal

700 So Kent St.
P.O. Box 450
Madison, NE 68748
District Phone (402) 454-3336 Fax (402) 454-2238
Elementary Phone (402) 454-2656 Fax (402) 454-3978

Travis Jordan
Director of CAI
Crystal Ernst
Instructional Coach
Landonn Mackey
Athletic Director
Celine Filsinger
Office Manager

The mission of Madison Public Schools is to prepare students to be competent, confident, productive, and responsible citizens.

Middle School Ipad Costs Breakdown- SFI Grant Funds

Brenthaven Edge Folio III Case for Ipad 10.2in	\$34.95ea (120)	\$4,194
Solo New York UBN210 Ludlow Universal Tablet Sling Tote - Black	\$32.50ea (120)	\$3,902.40
4-Year AppleCare+ for Schools - iPad 7th Gen. no service fee	\$79.00ea. (120)	\$9,480
10.2-inch iPad Wi-Fi 128GB - Space Gray (10-pack)	\$394.00ea (120)	<u>\$47,280</u>
	Total	\$64,856.40

Apple Inc. Education Price Quote

Customer:	Trish Braithwait MADISON PUBLIC SCHOOL SCHOOL DISTRICT NO 1 Phone: 4026405680 email: tbraithwait@me.com	Apple Inc:	Ryan Meyer One Apple Park Way Cupertino, CA 95014 email: meyer@apple.com
------------------	---	-------------------	---

Apple Quote: 2206435924

Quote Date: Monday, August 03, 2020

Quote Valid Until: Thursday, August 20, 2020

Quote Comments:

Please reference Apple Quote number on your Purchase Order.

Row #	Details & Comments	Qty	Unit List Price	Extended List Price
1	4-Year AppleCare+ for Schools - iPad 7th Gen. no service fee Part Number: S7832LL/A	120	\$79.00	\$9,480.00
2	10.2-inch iPad Wi-Fi 128GB - Space Gray (10-pack) Part Number: MW7P2LL/A	120	\$394.00	\$47,280.00
3	Brenthaven Edge Folio III Case for iPad 10.2 inch (7th Gen) - Gray (10-pack) Part Number: BQDD2LL/A	12	\$349.50	\$4,194.00
	Brenthaven Edge Folio III Case for iPad 10.2 inch (7th Gen) - Gray Part Number: HNWE2LL/A Quantity: 120			

Edu List Price Total \$60,954.00

- Additional Tax \$0.00

- Estimated Tax \$0.00

Extended Total Price* \$60,954.00

*In most cases Extended Total Price does not include Sales Tax

Clothing, Shoes & Jewelry ▾ Enter keyword or product n

Deliver to Madison
Madison 68748

Departments

Buy Again

EN

Hello, Madison
Account for Madison Pub...

Lists Try
Business Prime

0

AMAZON FASHION WOMEN MEN GIRLS BOYS BABY LUGGAGE SALES & DEALS YOUR FASHION & S

Electronics > Computers & Accessories > Tablet Accessories > Bags, Cases & Sleeves > Bags

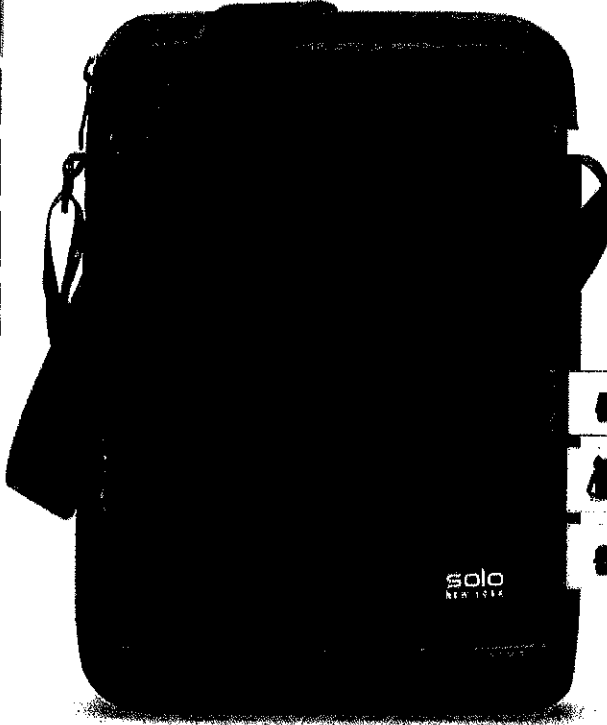

Roll over image to zoom in

New York UBN210 Ludlow Universal Tablet Sling Tote - Black

New York



629 ratings

answered questions

\$32.52 & FREE Shipping. Details
& FREE Returns

Available at a lower price from other sellers
that may not offer free Prime shipping.

Black

-  \$32.52
-  \$29.86
-  31 options from \$18.20

ded compartment protects tablets
up to 11 inches
Front zippered pocket
Front zip down organizer section
Adjustable shoulder strap and polyester

body
• 9.5x2.5x13

Compare with similar items

New & Used (7) from \$18.80 & FREE
Shipping on orders over \$25.00

Report incorrect product information.

 **iPhone 11 & Wireless Plans**
presented by Amazon
Shop now

\$32.52
& **FREE Shipping.** Details
& **FREE Returns**

Arrives: **Tuesday, Aug 11** Details

In Stock.

Qty: 1

Add to Cart

Secure transaction

Ships from and sold by
Amazon.com.

Add a Protection Plan:

- Assurant B2B 4YR Luggage Protection Plan with Accidental Damage \$25-49 for \$13.38
- Assurant B2B 3YR Luggage Protection Plan with Accidental Damage \$25-49 for \$9.66

Add gift options

Deliver to Madison - Madison
68748

Add to List

New & Used (7) from
\$18.80 & FREE Shipping on
orders over \$25.00

Share

Other Sellers on Amazon

\$31.99 Add to Cart

& **FREE Shipping** on eligible orders.

Details

Sold by: kazana

\$31.99 Add to Cart

+ Free Shipping

Sold by: NEW APPLE

\$32.51 Add to Cart

& **FREE Shipping** on eligible orders.

Details

Sold by: AMMarket

Have one to sell?

Frequently bought together

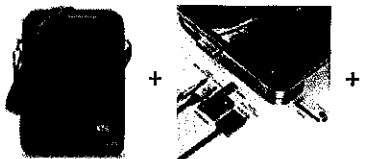

Total price: **\$211.42**

Add all three to Cart

These Items are shipped from and sold by different sellers. Show details

This item: Solo New York UBN210 Ludlow Universal Tablet Sling Tote - Black \$32.52

iPad Pro USB C Hub, Baseus 6-in-1 Adapter for iPad Pro 2018 2020 12.9/11 inch, Docking Station with... \$49.90

Apple Pencil (2nd Generation) \$129.00



SIGN IN SHIPPING & PAYMENT GIFT OPTIONS PLACE ORDER

Review your order

Save your checkout settings as the default for future orders
Use the selected group, shipping address, and payment method as my checkout defaults.

Keep your operating hours updated:
Confirm your operating hours: If your business' operating hours have changed, you can click **Edit delivery preferences** below the shipping address and update them. Your delivery preferences help us improve your delivery experience. However, we may not always be able to adhere to all preferences.

Place your order

By placing your order, you agree to the Amazon Business Accounts Terms & Conditions.

Order Summary

Items (120):	\$3,902.40
Shipping & handling:	\$58.07
Free Shipping:	-\$58.07
Total before tax:	\$3,902.40
Estimated tax to be collected:	\$0.00

Order total: \$3,902.40

Qualifying offers:

- Free Shipping

How are shipping costs calculated?

You got free shipping on the eligible items in your order! (Why aren't all my items eligible?)

Group Madison Public Schools Change	Payment method Change ending in Amazon Business Line of Credit ending in 2908	Add a gift card, promotion code, or voucher <input type="text" value="Enter Code"/> <input type="button" value="Apply"/>
Shipping address Change Madison Public School 700 S KENT ST MADISON, NE 68748-6279 United States Phone: 402-454-3336 Edit delivery preferences Ship to multiple addresses	Billing address Change Business Manager POB 450 Madison, NE 68748 United States	

Business order information Change
PO number No value entered

FREE 30-day trial

Why wait? Get faster delivery with Business Prime! [Try Business Prime now](#)

Business Prime provides FREE Prime Delivery and discounts on eligible items. The best of Amazon Business. Cancel anytime.

Estimated delivery: Aug. 30, 2020 - Sept. 16, 2020

 Solo New York UBN210 Ludlow Universal Tablet Sling Tote - Black \$32.52 Business Prime eligible Join now Quantity: 120 Change Sold by: Amazon.com Services LLC <input type="button" value="Add a gift receipt"/> and see other gift options Tax Exemption Applied. Remove	Choose a delivery option:
	<input type="radio"/> Monday, Aug. 24 - Wednesday, Sept. 9 FREE Prime Delivery with a free trial of businessprime <input checked="" type="radio"/> Sunday, Aug. 30 - Wednesday, Sept. 16 FREE Shipping <input type="radio"/> Thursday, Aug. 27 - Thursday, Sept. 10 \$58.07 - Shipping <input type="radio"/> Monday, Aug. 24 - Wednesday, Sept. 9 \$70.39 - Shipping

Do you need help? Explore our Help pages or contact us

For an item sold by Amazon.com: When you click the "Place your order" button, we'll send you an email message acknowledging receipt of your order. Your contract to purchase an item will not be complete until we send you an email notifying you that the item has been shipped.

Colorado, Louisiana and Puerto Rico Purchasers: Important information regarding sales tax you may owe in your State

Within 30 days of delivery, you may return new, unopened merchandise in its original condition. Exceptions and restrictions apply. See Amazon.com's Returns Policy

Madison Public Schools

Alan Ehlers
Superintendent
Jim Crilly
HS Principal
Reid Ehrisman
MS Principal/EL
Karla Kush
Elementary Principal

700 So Kent St.
P.O. Box 450
Madison, NE 68748
District Phone (402) 454-3336 Fax (402) 454-2238
Elementary Phone (402) 454-2656 Fax (402) 454-3978

Travis Jordan
Director of CAI
Crystal Ernst
Instructional Coach
Landonn Mackey
Athletic Director
Celine Filsinger
Office Manager

The mission of Madison Public Schools is to prepare students to be competent, confident, productive, and responsible citizens.

Middle School Ipad Costs Breakdown- SFI Grant Funds

Brenthaven Edge Folio III Case for Ipad 10.2in	\$34.95ea (120)	\$4,194
Solo New York UBN210 Ludlow Universal Tablet Sling Tote - Black	\$32.50ea (120)	\$3,902.40
4-Year AppleCare+ for Schools - iPad 7th Gen. no service fee	\$79.00ea. (120)	\$9,480
10.2-inch iPad Wi-Fi 128GB - Space Gray (10-pack)	\$394.00ea (120)	<u>\$47,280</u>
	Total	\$64,856.40

Apple Inc. Education Price Quote

Customer:	Trish Braithwait MADISON PUBLIC SCHOOL SCHOOL DISTRICT NO 1 Phone: 4026405680 email: tbraithwait@me.com	Apple Inc:	Ryan Meyer One Apple Park Way Cupertino, CA 95014 email: meyer@apple.com
------------------	---	-------------------	---

Apple Quote: 2206435924

Quote Date: Monday, August 03, 2020

Quote Valid Until: Thursday, August 20, 2020

Quote Comments:

Please reference Apple Quote number on your Purchase Order.

Row #	Details & Comments	Qty	Unit List Price	Extended List Price
1	4-Year AppleCare+ for Schools - iPad 7th Gen. no service fee Part Number: S7832LL/A	120	\$79.00	\$9,480.00
2	10.2-inch iPad Wi-Fi 128GB - Space Gray (10-pack) Part Number: MW7P2LL/A	120	\$394.00	\$47,280.00
3	Brenthaven Edge Folio III Case for iPad 10.2 inch (7th Gen) - Gray (10-pack) Part Number: BQDD2LL/A	12	\$349.50	\$4,194.00
	Brenthaven Edge Folio III Case for iPad 10.2 inch (7th Gen) - Gray Part Number: HNWE2LL/A Quantity: 120			

Edu List Price Total \$60,954.00

- Additional Tax \$0.00

- Estimated Tax \$0.00

Extended Total Price* \$60,954.00

*In most cases Extended Total Price does not include Sales Tax

Clothing, Shoes & Jewelry ▾ Enter keyword or product n

Deliver to Madison
Madison 68748

Departments

Buy Again

EN

Hello, Madison
Account for Madison Pub...

Lists Try Business Prime

0

AMAZON FASHION WOMEN MEN GIRLS BOYS BABY LUGGAGE SALES & DEALS YOUR FASHION & S

Electronics > Computers & Accessories > Tablet Accessories > Bags, Cases & Sleeves > Bags



VIDEO

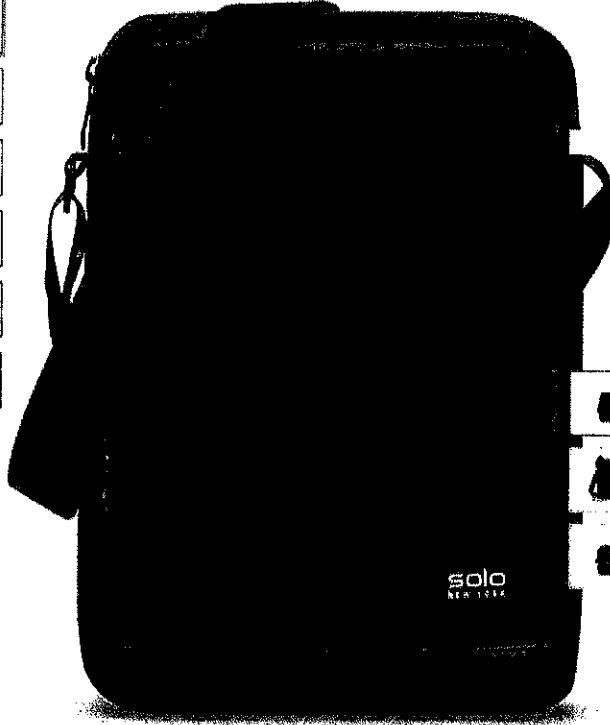

Roll over image to zoom in

New York UBN210 Ludlow Universal Tablet Sling Tote - Black

New York

629 ratings

answered questions

\$32.52 & FREE Shipping. Details
& FREE Returns

Available at a lower price from other sellers
that may not offer free Prime shipping.

Black

- \$32.52
- \$29.86
- 31 options from \$18.20

ded compartment protects tablets
up to 11 inches
Front zippered pocket
Front zip down organizer section
Adjustable shoulder strap and polyester

body
• 9.5x2.5x13

Compare with similar items

New & Used (7) from \$18.80 & FREE
Shipping on orders over \$25.00

Report incorrect product information.

iPhone 11 & Wireless Plans
presented by Amazon
Shop now

\$32.52
& FREE Shipping. Details
& FREE Returns

Arrives: Tuesday, Aug 11 Details

In Stock.

Qty: 1

Add to Cart

Secure transaction

Ships from and sold by
Amazon.com.

Add a Protection Plan:

- Assurant B2B 4YR Luggage Protection Plan with Accidental Damage \$25-49 for \$13.38
- Assurant B2B 3YR Luggage Protection Plan with Accidental Damage \$25-49 for \$9.66

Add gift options

Deliver to Madison - Madison
68748

Add to List

New & Used (7) from
\$18.80 & FREE Shipping on
orders over \$25.00

Share

Other Sellers on Amazon

\$31.99

& FREE Shipping on eligible orders.

Details

Sold by: kazana

\$31.99

+ Free Shipping

Sold by: NEW APPLE

\$32.51

& FREE Shipping on eligible orders.

Details

Sold by: AMMarket

Have one to sell?

Frequently bought together



Total price: \$211.42

These items are shipped from and sold by different sellers. Show details

This item: Solo New York UBN210 Ludlow Universal Tablet Sling Tote - Black \$32.52

iPad Pro USB C Hub, Baseus 6-in-1 Adapter for iPad Pro 2018 2020 12.9/11 inch, Docking Station with... \$49.90

Apple Pencil (2nd Generation) \$129.00



SIGN IN SHIPPING & PAYMENT GIFT OPTIONS PLACE ORDER

Review your order

Save your checkout settings as the default for future orders
Use the selected group, shipping address, and payment method as my checkout defaults.

Keep your operating hours updated:
Confirm your operating hours: If your business' operating hours have changed, you can click **Edit delivery preferences** below the shipping address and update them. Your delivery preferences help us improve your delivery experience. However, we may not always be able to adhere to all preferences.

Place your order

By placing your order, you agree to the Amazon Business Accounts Terms & Conditions.

Order Summary

Items (120):	\$3,902.40
Shipping & handling:	\$58.07
Free Shipping:	-\$58.07
Total before tax:	\$3,902.40
Estimated tax to be collected:	\$0.00

Order total: \$3,902.40

Qualifying offers:

- Free Shipping

How are shipping costs calculated?

You got free shipping on the eligible items in your order! (Why aren't all my items eligible?)

Group Madison Public Schools Change	Payment method Change ending in Amazon Business Line of Credit ending in 2908	Add a gift card, promotion code, or voucher <input type="text" value="Enter Code"/> <input type="button" value="Apply"/>
Shipping address Change Madison Public School 700 S KENT ST MADISON, NE 68748-6279 United States Phone: 402-454-3336 Edit delivery preferences Ship to multiple addresses	Billing address Change Business Manager POB 450 Madison, NE 68748 United States	

Business order information Change
PO number No value entered

FREE 30-day trial

Why wait? Get faster delivery with Business Prime! [Try Business Prime now](#)

Business Prime provides FREE Prime Delivery and discounts on eligible items. The best of Amazon Business. Cancel anytime.

Estimated delivery: Aug. 30, 2020 - Sept. 16, 2020

 Solo New York UBN210 Ludlow Universal Tablet Sling Tote - Black \$32.52 Business Prime eligible Join now Quantity: 120 Change Sold by: Amazon.com Services LLC <input type="button" value="Add a gift receipt"/> and see other gift options Tax Exemption Applied. Remove	Choose a delivery option:
	<input type="radio"/> Monday, Aug. 24 - Wednesday, Sept. 9 FREE Prime Delivery with a free trial of businessprime <input checked="" type="radio"/> Sunday, Aug. 30 - Wednesday, Sept. 16 FREE Shipping <input type="radio"/> Thursday, Aug. 27 - Thursday, Sept. 10 \$58.07 - Shipping <input type="radio"/> Monday, Aug. 24 - Wednesday, Sept. 9 \$70.39 - Shipping

Do you need help? Explore our Help pages or contact us

For an item sold by Amazon.com: When you click the "Place your order" button, we'll send you an email message acknowledging receipt of your order. Your contract to purchase an item will not be complete until we send you an email notifying you that the item has been shipped.

Colorado, Louisiana and Puerto Rico Purchasers: Important information regarding sales tax you may owe in your State

Within 30 days of delivery, you may return new, unopened merchandise in its original condition. Exceptions and restrictions apply. See Amazon.com's Returns Policy

2006 Complaint Procedure

Good communication helps to resolve many misunderstandings and disagreements. This complaint procedure applies to board members, patrons, students and school staff, unless the staff member is subject to a different grievance procedure pursuant to policy or contract. Individuals who have a complaint should discuss their concerns with appropriate school personnel in an effort to resolve problems. When such efforts do not resolve matters satisfactorily, including matters involving discrimination or harassment on the basis of race, color, national origin, sex, marital status, disability, or age, a complainant should follow the procedures set forth below. Students and employees who believe they have been subjected to sex harassment in violation of Title IX should refer to the board's policy titled "Title IX."

A preponderance of the evidence will be required to discipline a party accused of misconduct. This means that the investigator must conclude that it is more likely than not that misconduct occurred.

Complaint and Appeal Process.

1. The first step is for the complainant to speak directly to the person(s) with whom the complainant has a concern. For example, a parent who is unhappy with a classroom teacher should initially discuss the matter with the teacher. However, the complainant should skip the first step if complainant believes speaking directly to the person would subject complainant to discrimination or harassment.
2. The second step is for the complainant to speak to the building principal, Title IX/504 coordinator, superintendent of schools, or president of the board of education, as set forth below.
 - a) Complaints about the operation, decisions, or personnel within a building should be submitted to the principal of the building.
 - b) Complaints about the operations of the school district or a building principal should be submitted in writing to the superintendent of schools.

- c) Complaints about the superintendent of schools should be submitted in writing to the president of the board of education.
 - d) Complaints involving discrimination or harassment on the basis of race, color, national origin, sex, marital status, disability, or age may also be submitted, at any time during the complaint procedure to the School District's Title IX/504 coordinator. Complaints involving discrimination or harassment may also be submitted at any time to the Office for Civil Rights, U.S. Department of Education: by email at OCR.KansasCity@ed.gov; by telephone at (816) 268-0550; or by fax at (816) 268-0599.
3. When a complainant submits a complaint to an administrator or to the Title IX/504 coordinator, the administrator or Title IX/504 coordinator shall promptly and thoroughly investigate the complaint, and shall:
- a) Determine whether the complainant has discussed the matter with the staff member involved.
 - 1) If the complainant has not, the administrator or Title IX/504 coordinator will urge the complainant to discuss the matter directly with that staff member, if appropriate.
 - 2) If the complainant refuses to discuss the matter with the staff member, the administrator or Title IX/504 coordinator shall, in his or her sole discretion, determine whether the complaint should be pursued further.
 - b) Strongly encourage the complainant to reduce his or her concerns to writing.
 - c) Interview the complainant to determine:
 - 1) All relevant details of the complaint;
 - 2) All witnesses and documents which the complainant believes support the complaint;

- 3) The action or solution which the complainant seeks.
 - d) Respond to the complainant. If the complaint involved discrimination or harassment, the response shall be in writing and shall be submitted within 180 calendar days after the administrator or Title IX/504 coordinator received the complaint.
4. If either the complainant or the accused party is not satisfied with the administrator's or the Title IX/504 coordinator's decision regarding a complaint he or she may appeal the decision to the superintendent.
 - a) This appeal must be in writing.
 - b) This appeal must be received by the superintendent no later than ten (10) calendar days from the date the administrator or Title IX/504 coordinator communicated his/her decision to the complainant.
 - c) The superintendent will investigate as he or she deems appropriate. However, all matters involving discrimination or harassment shall be promptly and thoroughly investigated.
 - d) Upon completion of this investigation, the superintendent will inform the complainant in writing of his or her decision. If the complaint involved discrimination or harassment, the superintendent shall submit the decision within 180 calendar days after the superintendent received complainant's written appeal.
5. If either the complainant or the accused party is not satisfied with the superintendent's decision regarding a complaint he or she may appeal the decision to the board.
 - a) This appeal must be in writing.
 - b) This appeal must be received by the board president no later than ten (10) calendar days from the date the superintendent communicated his/her decision to the complainant.

- c) This policy allows, but does not require the board to receive statements from interested parties and witnesses relevant to the complaint appeal. However, all matters involving discrimination or harassment shall be promptly and thoroughly investigated.
 - d) The board will notify the complainant in writing of its decision. If the complaint involved discrimination or harassment, the board shall submit its decision within 180 calendar days after it received complainant's written appeal.
 - e) There is no appeal from a decision of the board.
6. When a formal complaint about the superintendent of schools has been filed with the president of the board, the president or his or her designee shall promptly and thoroughly investigate the complaint, and shall:
- a) Determine whether the complainant has discussed the matter with the superintendent.
 - 1) If the complainant has not, the board president or designee will urge the complainant to discuss the matter directly with the superintendent, if appropriate.
 - 2) If the complainant refuses to discuss the matter with the superintendent, the board president shall, in his or her sole discretion, determine whether the complaint should be pursued further.
 - b) Strongly encourage the complainant to reduce his or her concerns to writing.
 - c) Determine, in his or her sole discretion, whether to place the matter on the board agenda for consideration at a regular or special meeting.
 - d) Respond to the complainant. If the complaint involved discrimination or harassment, the response shall be in writing and shall be submitted within 180 calendar days after the president received the complaint.

No Retaliation. The school district prohibits retaliation against any person for filing a complaint or for participating in the complaint procedure in good faith.

Special Rules Regarding Educational Services and Related Services to Students with Disabilities. Students with disabilities and their families have specific rights outlined in state and federal law, including administrative processes by which they may challenge the educational services being provided by the school district. Therefore, the appeal process contained in this policy may not be used to challenge decisions made by a student's individualized education plan (IEP) team or 504 team.

Complaints about the educational services provided a student with a disability, including but not limited to services provided to a student with an IEP, access to curricular and extracurricular activities, and educational placement must be submitted to the school district's Director of Special Education. The Director of Special Education will address the complaint in a manner that he/she deems appropriate and will provide the complainant with a copy of the Notice of IDEA Parental Rights promulgated by the Nebraska Department of Education.

Complaints about the educational services provided a student with a disability pursuant to a Section 504 plan must be submitted to the school district's 504 Coordinator. The 504 Coordinator will address the complaint in a manner that he/she deems appropriate and will provide the complainant with a copy of the Notice of Section 504 Parental Rights adopted by the board of education.

Complaints about the educational services provided to a student who is suspected of having a disability must be submitted in writing to the school district's Director of Special Education or to the district's 504 Coordinator. The Director of Special Education or 504 Coordinator will either refer the student for possible verification as a student with a disability or will provide prior written notice of the district's refusal to do so.

Bad Faith or Serial Filings. The purpose of the complaint procedure is to resolve complaints at the lowest level possible within the chain of command. Individuals who file complaints (a) without a good faith intention to attempt to resolve the issues raised; (b) for the purpose of adding administrative burden; (c) at a volume unreasonable to expect satisfactory resolution; or (c) for purposes inconsistent with the efficient operations of the district may be dismissed by the superintendent

without providing final resolution other than noting the dismissal. There is no appeal from dismissals made pursuant to this section.

Adopted on: 8/10/2020

Revised on: _____

Reviewed on: _____

3057
Title IX Policy

It is the policy of the school district that no person shall, on the basis of sex, be excluded from participation in, be denied the benefits of, or be subject to discrimination under any of the school district's programs or activities. The district is required by Title IX (20 U.S.C. § 1681) and 34 C.F.R. part 106 to not discriminate in such a manner.

1. Title IX Coordinator

1.1. **Designation.** The district will designate and authorize at least one employee to coordinate its efforts to comply with its responsibilities under this policy, who will be referred to as the "**Title IX Coordinator.**" The district will notify applicants for admission and employment, students, parents or legal guardians of students, employees, and all unions or professional organizations holding collective bargaining or professional agreements with the district, of the name or title, office address, electronic mail address, and telephone number of the Title IX Coordinator. Any person may report sex discrimination, including sexual harassment (whether or not the person reporting is the person alleged to be the victim of conduct that could constitute sex discrimination or sexual harassment). This report may be made by any means, including but not limited to, in person, by mail, by telephone, or by electronic mail, using the contact information listed for the Title IX Coordinator, or by any other means that results in the Title IX Coordinator receiving the person's verbal or written report. Such a report may be made at any time (including during non-business hours).

2. Definitions. As used in this policy, the following terms are defined as follows:

2.1. **Actual knowledge** means notice of sexual harassment or allegations of sexual harassment to any district employee. Imputation of knowledge based solely on vicarious liability or constructive notice is insufficient to constitute actual knowledge. This standard is not met when the only district employee with actual knowledge is the respondent (as that term is defined below). "Notice" as used in this paragraph includes, but is not limited to, a report of sexual harassment to the Title IX Coordinator as described in subsection 1.1 above.

2.2. **Complainant** means an individual who is alleged to be the victim of conduct that could constitute sexual harassment.

2.3. **Formal complaint** means a document filed by a complainant or signed by the Title IX Coordinator alleging sexual harassment against a respondent and requesting that the district investigate the allegation of sexual harassment. The only district official who is authorized to initiate the Grievance Process for Formal Complaints of Sexual Harassment against a respondent is the Title IX Coordinator (by signing a formal complaint). At the time of filing a formal complaint with the district, a complainant must be participating in or attempting to participate in the district's education program or activity. A formal complaint may be filed with the Title IX Coordinator in person, by mail, or by electronic mail, by using the contact information required to be listed for the Title IX Coordinator under subsection 1.1 above, and by any additional method designated by the district. As used in this paragraph, the phrase "document filed by a complainant" means a document or electronic submission (such as by electronic mail or through an online portal provided for this purpose by the district) that contains the complainant's physical or digital signature, or otherwise indicates that the complainant is the person filing the formal complaint. Where the Title IX Coordinator signs a formal complaint, the Title IX Coordinator is not a complainant or otherwise a party under this policy or under 34 C.F.R. part 106, and will comply with the requirements of this policy and 34 C.F.R. part 106, including subsections 5.1.3–5.1.4 and 34 C.F.R. § 106.45(b)(1)(iii).

2.4. **Respondent** means an individual who has been reported to be the perpetrator of conduct that could constitute sexual harassment.

2.5. **Consent** for purposes of this policy means the willingness in fact for conduct to occur. An individual may, as a result of age, incapacity, disability, lack of information, or other circumstances be incapable of providing consent to some or all sexual conduct or activity. Neither verbal nor physical resistance is required to establish that an individual did not consent. District officials will consider the totality of the circumstances in determining whether there was consent for any specific conduct. Consent may be revoked or withdrawn at any time.

2.6. **Sexual harassment** means conduct on the basis of sex that satisfies one or more of the following:

- 2.6.1. An employee of the district conditioning the provision of an aid, benefit, or service of the district on an individual's participation in unwelcome sexual conduct;
- 2.6.2. Unwelcome conduct determined by a reasonable person to be so severe, pervasive, and objectively offensive that it

effectively denies a person equal access to the district's education program or activity;

2.6.3. **Sexual assault**, as defined in 20 U.S.C. § 1092(f)(6)(A)(v), which means an offense classified as a forcible or nonforcible sex offense under the uniform crime reporting system of the Federal Bureau of Investigation:

2.6.3.1. **Sex Offenses, Forcible**—Any sexual act directed against another person, without the consent of the victim including instances where the victim is incapable of giving consent.

2.6.3.1.1. **Rape**—(Except Statutory Rape) The carnal knowledge of a person, without the consent of the victim, including instances where the victim is incapable of giving consent because of his/her age or because of his/her temporary or permanent mental or physical incapacity.

2.6.3.1.2. **Sodomy**—Oral or anal sexual intercourse with another person, without the consent of the victim, including instances where the victim is incapable of giving consent because of his/her age or because of his/her temporary or permanent mental or physical incapacity

2.6.3.1.3. **Sexual Assault With An Object**—To use an object or instrument to unlawfully penetrate, however slightly, the genital or anal opening of the body of another person, without the consent of the victim, including instances where the victim is incapable of giving consent because of his/her age or because of his/her temporary or permanent mental or physical incapacity

2.6.3.1.4. **Fondling**—The touching of the private body parts of another person for the purpose of sexual gratification, without the consent of the victim, including instances where the victim is incapable of giving consent because of his/her age or because of his/her temporary or permanent mental or physical incapacity

- 2.6.3.2. **Sex Offenses, Non-forcible**—(Except Prostitution Offenses) Unlawful, non-forcible sexual intercourse.
 - 2.6.3.2.1. **Incest**—Non-Forcible sexual intercourse between persons who are related to each other within the degrees wherein marriage is prohibited by law
 - 2.6.3.2.2. **Statutory Rape**—Non-Forcible sexual intercourse with a person who is under the statutory age of consent
- 2.6.4. **Dating violence**, as defined in 34 U.S.C. § 12291(a)(10), which means violence committed by a person—
 - 2.6.4.1. who is or has been in a social relationship of a romantic or intimate nature with the victim; and
 - 2.6.4.2. where the existence of such a relationship shall be determined based on a consideration of the following factors:
 - 2.6.4.2.1. The length of the relationship.
 - 2.6.4.2.2. The type of relationship.
 - 2.6.4.2.3. The frequency of interaction between the persons involved in the relationship.
- 2.6.5. **Domestic violence**, as defined in 34 U.S.C. § 12291(a)(8), which includes felony or misdemeanor crimes of violence committed by a current or former spouse or intimate partner of the victim, by a person with whom the victim shares a child in common, by a person who is cohabitating with or has cohabitated with the victim as a spouse or intimate partner, by a person similarly situated to a spouse of the victim under the domestic or family violence laws of the jurisdiction receiving grant monies, or by any other person against an adult or youth victim who is protected from that person's acts under the domestic or family violence laws of the jurisdiction.

2.6.6. **Stalking**, as defined in 34 U.S.C. § 12291(a)(30), which means engaging in a course of conduct directed at a specific person that would cause a reasonable person to—

2.6.6.1. fear for his or her safety or the safety of others; or

2.6.6.2. suffer substantial emotional distress.

2.7. **Supportive measures** means non-disciplinary, non-punitive individualized services offered as appropriate, as reasonably available, and without fee or charge to the complainant or the respondent before or after the filing of a formal complaint or where no formal complaint has been filed. Such measures are designed to restore or preserve equal access to the district's education program or activity without unreasonably burdening the other party, including measures designed to protect the safety of all parties or the district's educational environment, or deter sexual harassment. Supportive measures may include counseling, extensions of deadlines or other course-related adjustments, modifications of work or class schedules, campus escort services, mutual restrictions on contact between the parties, changes in work or housing locations, leaves of absence, increased security and monitoring of certain areas of the campus, and other similar measures. The district will maintain as confidential any supportive measures provided to the complainant or respondent, to the extent that maintaining such confidentiality would not impair the ability of the district to provide the supportive measures. The Title IX Coordinator is responsible for coordinating the effective implementation of supportive measures.

3. Discrimination Not Involving Sexual Harassment.

3.1. **General Prohibition.** Except as provided elsewhere in Title IX, 34 C.F.R. part 106, or this policy, no person shall, on the basis of sex, be excluded from participation in, be denied the benefits of, or be subjected to discrimination under any academic, extracurricular, research, occupational training, or other education program or activity operated by the district.

3.2. **Specific Prohibitions.** Except as provided elsewhere in Title IX, 34 C.F.R. part 106, or this policy, in providing any aid, benefit, or service to a student, the district will not on the basis of sex:

- 3.2.1. Treat one person differently from another in determining whether such person satisfies any requirement or condition for the provision of such aid, benefit, or service;
- 3.2.2. Provide different aid, benefits, or services or provide aid, benefits, or services in a different manner;
- 3.2.3. Deny any person any such aid, benefit, or service;
- 3.2.4. Subject any person to separate or different rules of behavior, sanctions, or other treatment;
- 3.2.5. Apply any rule concerning the domicile or residence of a student or applicant;
- 3.2.6. Aid or perpetuate discrimination against any person by providing significant assistance to any agency, organization, or person which discriminates on the basis of sex in providing any aid, benefit or service to students or employees;
- 3.2.7. Otherwise limit any person in the enjoyment of any right, privilege, advantage, or opportunity.

3.3. Complaint Procedure. All complaints regarding any alleged discrimination on the basis of sex, including without limitation violations of this policy, 34 C.F.R. part 106, Title IX, Title VII, or other state or federal law—when the alleged discrimination does not arise from or relate to an allegation of sexual harassment as defined in subsection 2.6 above—shall be addressed pursuant to the district’s general complaint procedure, Board Policy 2006.

4. **Response to Sexual Harassment**

4.1. Reporting Sexual Harassment. Any person who witnesses an act of unlawful sexual harassment is encouraged to report it to the District’s Title IX Coordinator. No person will be retaliated against based on any report of suspected sexual harassment or retaliation. Any District employee who receives a report of sexual harassment or has actual knowledge of sexual harassment must convey that information to the Title IX Coordinator as soon as reasonably practicable, but in no case later than the end of the following school day.

4.2. General Response to Sexual Harassment. When the district has actual knowledge of sexual harassment in its education program or activity against a person in the United States, the district will respond promptly in a manner that is not deliberately indifferent. The district will be deemed to be deliberately indifferent only if its response to sexual harassment is clearly unreasonable in light of the known circumstances. For the purposes of this policy “education program or activity” includes locations, events, or circumstances over which the district exercised substantial control over both the respondent and the context in which the sexual harassment occurs. The district’s response will treat complainants and respondents equitably by offering supportive measures as defined in subsection 2.7 above to a complainant, and by following the grievance process described in section 5 below before the imposition of any disciplinary sanctions or other actions that are not supportive measures, against a respondent. The Title IX Coordinator will promptly contact the complainant to discuss the availability of supportive measures, consider the complainant’s wishes with respect to supportive measures, inform the complainant of the availability of supportive measures with or without the filing of a formal complaint, and explain to the complainant the process for filing a formal complaint.

4.3. Emergency Removal. Nothing in this policy precludes the district from removing a respondent from the district’s education program or activity on an emergency basis, provided that the district undertakes an individualized safety and risk analysis, and determines that an immediate threat to the physical health or safety of any student or other individual arising from the allegations of sexual harassment justifies removal. In the event that the district so removes a respondent on an emergency basis, then the district will provide the respondent with notice and an opportunity to challenge the decision immediately following the removal. This provision may not be construed to modify any rights under the Individuals with Disabilities Education Act, Section 504 of the Rehabilitation Act of 1973, or the Americans with Disabilities Act.

4.4. Administrative Leave. Nothing in this policy precludes the district from placing a non-student employee respondent on administrative leave during the pendency of a grievance process that complies with section 5 below. This provision may not be construed to modify any rights under Section 504 of the Rehabilitation Act of 1973 or the Americans with Disabilities Act.

4.5. **General Response Not Conditioned on Formal Complaint.** With or without a formal complaint, the district will comply with the obligations and procedures described in this section 4.

5. **Grievance Process for Formal Complaints of Sexual Harassment.**

5.1. **General Requirements.**

- 5.1.1. **Equitable Treatment.** The district will treat complainants and respondents equitably by providing remedies to a complainant where a determination of responsibility for sexual harassment has been made against the respondent, and by following the grievance process described in this section 5 before the imposition of any disciplinary sanctions or other actions that are not supportive measures against a respondent. Remedies will be designed to restore or preserve equal access to the district's education program or activity. Remedies may include the same individualized services described in subsection 2.7 as "supportive measures"; however, remedies need not be non-disciplinary or non-punitive and need not avoid burdening the respondent.
- 5.1.2. **Objective Evaluation.** This grievance process requires an objective evaluation of all relevant evidence—including both inculpatory and exculpatory evidence. Credibility determinations may not be based on a person's status as a complainant, respondent, or witness.
- 5.1.3. **Absence of Conflicts of Interest or Bias.** The district will require that any individual designated by a recipient as a Title IX Coordinator, investigator, decision-maker, or any person designated by a recipient to facilitate an informal resolution process, not have a conflict of interest or bias for or against complainants or respondents generally or an individual complainant or respondent.
- 5.1.4. **Training.** The district will ensure that all individuals or entities described in this Training section 5.1.4 receive training as provided below. Any materials used to train these individuals will not rely on sex stereotypes and will promote impartial investigations and adjudications of formal complaints of sexual harassment.

- 5.1.4.1. **All District Employees and Board Members.** All district employees and board members will be trained on how to identify and report sexual harassment.
- 5.1.4.2. **Title IX Coordinators, Investigators, Decision-Makers, or Informal Resolution Facilitators.** The district will ensure that Title IX Coordinators, investigators, decision-makers, or any person designated by the district to facilitate an informal resolution process receive training on:
 - 5.1.4.2.1. The definition of sexual harassment in subsection 2.6;
 - 5.1.4.2.2. The scope of the district's education program or activity;
 - 5.1.4.2.3. How to conduct an investigation and grievance process including hearings, appeals, and informal resolution processes, as applicable; and
 - 5.1.4.2.4. How to serve impartially, including by avoiding prejudgment of the facts at issue, conflicts of interest, and bias.
- 5.1.4.3. **Decision-Makers.** The district will ensure that decision-makers receive training on issues of relevance of questions and evidence, including when questions and evidence about the complainant's sexual predisposition or prior sexual behavior are not relevant, as set forth in subsection 5.6.
- 5.1.4.4. **Investigators.** The district will also ensure that investigators receive training on issues of relevance to create an investigative report that fairly summarizes relevant evidence, as set forth in subsection 5.5.8.
- 5.1.5. **Presumption.** It is presumed that the respondent is not responsible for the alleged conduct until a determination regarding responsibility is made at the conclusion of the grievance process.

- 5.1.6. **Reasonably Prompt Time Frames.** This grievance process shall include reasonably prompt time frames for conclusion of the grievance process, including reasonably prompt time frames for filing and resolving appeals and informal resolution processes if the district offers informal resolution processes. The process shall also allow for the temporary delay of the grievance process or the limited extension of time frames for good cause with written notice to the complainant and the respondent of the delay or extension and the reasons for the action. Good cause may include considerations such as the absence of a party, a party's advisor, or a witness; concurrent law enforcement activity; or the need for language assistance or accommodation of disabilities.
- 5.1.7. **Range of Possible Sanctions and Remedies.** Following a determination of responsibility, the district may impose disciplinary sanctions and remedies in conformance with this and the district's student discipline policy, and other state and federal laws. Depending upon the circumstances, these policies provide for disciplinary sanctions and remedies up to and including expulsion.
- 5.1.8. **Range of Supportive Measures.** The range of supportive measures available to complainants and respondents include those listed in subsection 2.7.
- 5.1.9. **Respect for Privileged Information.** The district will not require, allow, rely upon, or otherwise use questions or evidence that constitute, or seek disclosure of, information protected under a legally recognized privilege, unless the person holding such privilege has waived the privilege.

5.2. **Notice of Allegations.**

- 5.2.1. **Initial Notice.** Upon receipt of a formal complaint, the district will provide the following written notice to the parties who are known:
- 5.2.1.1. A copy of this policy.
 - 5.2.1.2. Notice of the allegations of sexual harassment potentially constituting sexual harassment as defined in subsection 2.6, including sufficient details known at

the time and with sufficient time to prepare a response before any initial interview. Sufficient details include the identities of the parties involved in the incident, if known, the conduct allegedly constituting sexual harassment, and the date and location of the alleged incident, if known. The written notice will include a statement that the respondent is presumed not responsible for the alleged conduct and that a determination regarding responsibility is made at the conclusion of the grievance process. The written notice will inform the parties that they may have an advisor of their choice, who may be, but is not required to be, an attorney, under subsection 5.5.5, and may inspect and review evidence under subsection 5.5.5. The written notice will inform the parties of any provision in the district's code of conduct that prohibits knowingly making false statements or knowingly submitting false information during the grievance process.

- 5.2.2. **Supplemental Notice.** If, in the course of an investigation, the district decides to investigate allegations about the complainant or respondent that are not included in the Initial Notice described above, the district will provide notice of the additional allegations to the parties whose identities are known.

5.3. **Dismissal of Formal Complaint.**

- 5.3.1. The district will investigate the allegations in a formal complaint.
- 5.3.2. **Mandatory Dismissals.** The district **must** dismiss a formal complaint if the conduct alleged in the formal complaint:
 - 5.3.2.1. Would not constitute sexual harassment as defined in subsection 2.6 even if proved;
 - 5.3.2.2. Did not occur in the district's education program or activity; or
 - 5.3.2.3. Did not occur against a person in the United States.

5.3.3. **Discretionary Dismissals.** The district **may** dismiss the formal complaint or any allegations therein, if at any time during the investigation or hearing:

5.3.3.1. The complainant notifies the Title IX Coordinator in writing that the complainant would like to withdraw the formal complaint or any allegations therein;

5.3.3.2. The respondent is no longer enrolled in or employed by the district; or

5.3.3.3. Specific circumstances prevent the district from gathering evidence sufficient to reach a determination as to the formal complaint or allegations therein.

5.3.4. Upon a dismissal required or permitted pursuant to subsections 5.3.2 or 5.3.3 above, the district will promptly send written notice of the dismissal and an explanation of that action simultaneously to the parties.

5.3.5. Dismissal of a formal complaint under this policy does not preclude the district from taking action under another provision of the district's code of conduct or pursuant to another district policy.

5.4. **Consolidation of Formal Complaints.** The district may consolidate formal complaints as to allegations of sexual harassment against more than one respondent, or by more than one complainant against one or more respondents, or by one party against the other party, where the allegations of sexual harassment arise out of the same facts or circumstances. Where a grievance process involves more than one complainant or more than one respondent, references in this policy to the singular "party," "complainant," or "respondent" include the plural, as applicable.

5.5. **Investigation of Formal Complaint.** When investigating a formal complaint and throughout the grievance process, the district will:

5.5.1. Designate and authorize one or more persons (which need not be district employees) as investigator(s) to conduct the district's investigation of a formal complaint;

5.5.2. Ensure that the burden of proof and the burden of gathering evidence sufficient to reach a determination regarding

responsibility rest on the district and not on the parties provided that the district cannot access, consider, disclose, or otherwise use a party's records that are made or maintained by a physician, psychiatrist, psychologist, or other recognized professional or paraprofessional acting in the professional's or paraprofessional's capacity, or assisting in that capacity, and which are made and maintained in connection with the provision of treatment to the party, unless the district obtains that party's voluntary, written consent to do so for a grievance process under this section (if a party is not an "eligible student," as defined in 34 CFR 99.3, then the district will obtain the voluntary, written consent of a "parent," as defined in 34 CFR 99.3);

- 5.5.3. Provide an equal opportunity for the parties to present witnesses, including fact and expert witnesses, and other inculpatory and exculpatory evidence;
- 5.5.4. Not restrict the ability of either party to discuss the allegations under investigation or to gather and present relevant evidence;
- 5.5.5. Provide the parties with the same opportunities to have others present during any grievance proceeding, including the opportunity to be accompanied to any related meeting or proceeding by the advisor of their choice, who may be, but is not required to be, an attorney, and not limit the choice or presence of advisor for either the complainant or respondent in any meeting or grievance proceeding; however, the district may establish restrictions regarding the extent to which the advisor may participate in the proceedings, as long as the restrictions apply equally to both parties;
- 5.5.6. Provide, to a party whose participation is invited or expected, written notice of the date, time, location, participants, and purpose of all hearings, investigative interviews, or other meetings, with sufficient time for the party to prepare to participate;
- 5.5.7. Provide both parties an equal opportunity to inspect and review any evidence obtained as part of the investigation that is directly related to the allegations raised in a formal complaint, including the evidence upon which the district

does not intend to rely in reaching a determination regarding responsibility and inculpatory or exculpatory evidence whether obtained from a party or other source, so that each party can meaningfully respond to the evidence prior to conclusion of the investigation. Prior to completion of the investigative report, the district will send to each party and the party's advisor, if any, the evidence subject to inspection and review in an electronic format or a hard copy, and the parties will have at least 10 calendar days to submit a written response, which the investigator will consider prior to completion of the investigative report; and

- 5.5.8. Create an investigative report that fairly summarizes relevant evidence and, at least 10 calendar days prior to the time of determination regarding responsibility, send to each party and the party's advisor, if any, the investigative report in an electronic format or a hard copy, for their review and written response.

5.6. Exchange of Written Questions. After the district has sent the investigative report to the parties pursuant to subsection 5.5.8, but before reaching a determination regarding responsibility, the decision-maker(s) will afford each party the opportunity to submit written, relevant questions that a party wants asked of any party or witness, provide each party with the answers, and allow for additional, limited follow-up questions from each party. Questions and evidence about the complainant's sexual predisposition or prior sexual behavior are not relevant, unless such questions and evidence about the complainant's prior sexual behavior are offered to prove that someone other than the respondent committed the conduct alleged by the complainant, or if the questions and evidence concern specific incidents of the complainant's prior sexual behavior with respect to the respondent and are offered to prove consent. The decision-maker(s) will explain to the party proposing the questions any decision to exclude a question as not relevant.

5.7. Determination Regarding Responsibility

- 5.7.1. **Decision-Maker(s).** The decision-maker(s) cannot be the same person as the Title IX Coordinator or the investigator(s).
- 5.7.2. **Written Determination.** The decision-maker(s) will issue a written determination regarding responsibility. To reach this determination, the decision-maker(s) will apply the

preponderance of the evidence standard. The written determination will include:

- 5.7.2.1. Identification of the allegations potentially constituting sexual harassment as defined in subsection 2.6;
- 5.7.2.2. A description of the procedural steps taken from the receipt of the formal complaint through the determination, including any notifications to the parties, interviews with parties and witnesses, site visits, methods used to gather other evidence, and hearings held;
- 5.7.2.3. Findings of fact supporting the determination;
- 5.7.2.4. Conclusions regarding the application of the district's code of conduct to the facts;
- 5.7.2.5. A statement of, and rationale for, the result as to each allegation, including a determination regarding responsibility, any disciplinary sanctions the district imposes on the respondent, and whether remedies designed to restore or preserve equal access to the district's education program or activity will be provided by the district to the complainant; and
- 5.7.2.6. The district's procedures and permissible bases for the complainant and respondent to appeal.

5.7.3. The district will provide the written determination to the parties simultaneously. The determination regarding responsibility becomes final either on the date that the district provides the parties with the written determination of the result of the appeal, if an appeal is filed, or if an appeal is not filed, the date on which an appeal would no longer be considered timely.

5.7.4. The Title IX Coordinator is responsible for effective implementation of any remedies.

5.8. **Appeals.** The district will offer both parties the opportunity to appeal from a determination regarding responsibility, and from the

district's dismissal of a formal complaint or any allegations therein, on the grounds identified below.

5.8.1. **Time for Appeal.** Appeals may only be initiated by submitting a written Notice of Appeal to the Office of the Superintendent of Schools within ten (10) calendar days of the date of the respective written determination of responsibility or dismissal from which the appeal is taken. The Notice of Appeal must include (a) the name of the party or parties making the appeal, (b) the determination, dismissal, or portion thereof being appealed, and (c) a concise statement of the specific grounds (from subsection 5.8.2 below) upon which the appeal is based. A party's failure to timely submit a Notice of Appeal will be deemed a waiver of the party's right to appeal under this policy, 34 C.F.R. part, 106, and Title IX.

5.8.2. **Grounds for Appeal.** Appeals from a determination regarding responsibility, and from the district's dismissal of a formal complaint or any allegations therein, are limited to the following grounds:

5.8.2.1. Procedural irregularity that affected the outcome of the matter;

5.8.2.2. New evidence that was not reasonably available at the time the determination regarding responsibility or dismissal was made, that could affect the outcome of the matter; and

5.8.2.3. The Title IX Coordinator, investigator(s), or decision-maker(s) had a conflict of interest or bias for or against complainants or respondents generally or the individual complainant or respondent that affected the outcome of the matter.

5.8.3. As to all appeals, the district will:

5.8.3.1. Notify the other party in writing when an appeal is filed and implement appeal procedures equally for both parties;

5.8.3.2. Ensure that the decision-maker(s) for the appeal is not the same person as the decision-maker(s) that

reached the determination regarding responsibility or dismissal, the investigator(s), or the Title IX Coordinator;

5.8.3.3. Ensure that the decision-maker(s) for the appeal complies with the standards set forth in subsections 5.1.3–5.1.4.

5.8.3.4. Give both parties a reasonable, equal opportunity to submit a written statement in support of, or challenging, the outcome;

5.8.3.5. Issue a written decision describing the result of the appeal and the rationale for the result; and

5.8.3.6. Provide the written decision simultaneously to both parties.

5.9. Informal Resolution. The district will not require as a condition of enrollment or continuing enrollment, or employment or continuing employment, or enjoyment of any other right, waiver of the right to an investigation and adjudication of formal complaints of sexual harassment consistent with this section. Similarly, the district will not require the parties to participate in an informal resolution process under this section and may not offer an informal resolution process unless a formal complaint is filed. However, at any time prior to reaching a determination regarding responsibility the district may facilitate an informal resolution process, such as mediation, that does not involve a full investigation and adjudication, provided that the district:

5.9.1. Provides to the parties a written notice disclosing:

5.9.1.1. The allegations;

5.9.1.2. The requirements of the informal resolution process including the circumstances under which it precludes the parties from resuming a formal complaint arising from the same allegations;

5.9.1.3. That at any time prior to agreeing to a resolution, any party has the right to withdraw from the informal resolution process and resume the grievance process with respect to the formal complaint; and

- 5.9.1.4. Any consequences resulting from participating in the informal resolution process, including the records that will be maintained or could be shared;
- 5.9.2. Obtains the parties' voluntary, written consent to the informal resolution process; and
- 5.9.3. Does not offer or facilitate an informal resolution process to resolve allegations that an employee sexually harassed a student.

5.10. Recordkeeping.

- 5.10.1. The district will maintain for a period of seven years records of:
 - 5.10.1.1. Each sexual harassment investigation including any determination regarding responsibility, any disciplinary sanctions imposed on the respondent, and any remedies provided to the complainant designed to restore or preserve equal access to the district's education program or activity;
 - 5.10.1.2. Any appeal and the result therefrom;
 - 5.10.1.3. Any informal resolution and the result therefrom; and
 - 5.10.1.4. All materials used to train Title IX Coordinators, investigators, decision-makers, and any person who facilitates an informal resolution process. The district will make these training materials publicly available on its website, or if the district does not maintain a website then the district will make these materials available upon request for inspection by members of the public.
- 5.10.2. For each response required under section 4, the district will create, and maintain for a period of seven years, records of any actions, including any supportive measures, taken in response to a report or formal complaint of sexual harassment. In each instance, the district will document the basis for its conclusion that its response was not deliberately indifferent, and document that it has taken measures

designed to restore or preserve equal access to the district's education program or activity. If the district does not provide a complainant with supportive measures, then the district will document the reasons why such a response was not clearly unreasonable in light of the known circumstances. The documentation of certain bases or measures does not limit the district in the future from providing additional explanations or detailing additional measures taken.

6. **Superintendent Authorized to Contract.** The board authorizes the Superintendent to contract for, designate, and appoint individuals to serve in the roles of the district's investigator(s), decision-maker(s), informal resolution facilitator(s), or appellate decision-maker(s) as contemplated by this policy.

7. **Access to Classes and Schools.**

7.1. **General Standard.** Except as provided in this section or otherwise in 34 C.F.R. part 106, the district will not provide or otherwise carry out any of its education programs or activities separately on the basis of sex, or require or refuse participation therein by any of its students on the basis of sex.

7.1.1. **Contact sports in physical education classes.** This section does not prohibit separation of students by sex within physical education classes or activities during participation in wrestling, boxing, rugby, ice hockey, football, basketball, and other sports the purpose or major activity of which involves bodily contact.

7.1.2. **Ability grouping in physical education classes.** This section does not prohibit grouping of students in physical education classes and activities by ability as assessed by objective standards of individual performance developed and applied without regard to sex.

7.1.3. **Human sexuality classes.** Classes or portions of classes that deal primarily with human sexuality may be conducted in separate sessions for boys and girls.

7.1.4. **Choruses.** The district may make requirements based on vocal range or quality that may result in a chorus or choruses of one or predominantly one sex.

7.2. **Classes and Extracurricular Activities.** The district may provide nonvocational single-sex classes or extracurricular activities as permitted by 34 C.F.R. part 106.

8. **Athletics.** It is the policy of the district that no person shall, on the basis of sex, be excluded from participation in, be denied the benefits of, be treated differently from another person or otherwise be discriminated against in any interscholastic, club, or intramural athletics offered by the district, and that the district will not provide any such athletics separately on such basis.

8.1. **Separate Teams.** Notwithstanding the foregoing paragraph, the district may operate or sponsor separate teams for members of each sex where selection for such teams is based upon competitive skill or the activity involved is a contact sport.

8.2. **Equal opportunity.** The district will provide equal athletic opportunity for members of both sexes. Unequal aggregate expenditures for members of each sex or unequal expenditures for male and female teams will not constitute noncompliance with this section.

9. **Certain Different Treatment on the Basis of Sex Permitted.** Nothing herein shall be construed to prohibit the district from treating persons differently on the basis of sex as permitted by Title IX or 34 C.F.R. part 106. For example, and without limiting the foregoing, the district may provide separate toilet, locker room, and shower facilities on the basis of sex, but such facilities provided for students of one sex shall be comparable to such facilities provided for students of the other sex.

10. **Retaliation Prohibited.** Neither the district nor any other person may intimidate, threaten, coerce, or discriminate against any individual for the purpose of interfering with any right or privilege secured by Title IX, 34 C.F.R. part 106, or this policy, or because the individual has made a report or complaint, testified, assisted, or participated or refused to participate in any manner in an investigation, proceeding, or hearing under this policy. The district will keep confidential the identity of any individual who has made a report or complaint of sex discrimination, including any individual who has made a report or filed a formal complaint of sexual harassment, any complainant, any individual who has been reported to be the perpetrator of sex discrimination, any respondent, and any witness, except as may be permitted by the FERPA statute, 20 U.S.C. § 1232g, or FERPA regulations, 34 C.F.R. part 99, or as required by law, or to carry out the purposes of 34 C.F.R. part 106, including the conduct of any investigation, hearing, or judicial

proceeding arising thereunder. Complaints alleging retaliation may be filed according to shall be addressed pursuant to Board Policy 2006 (Complaint Procedure).

10.1. **Specific Circumstances.**

10.1.1. The exercise of rights protected under the First Amendment does not constitute retaliation prohibited by this section.

10.1.2. Charging an individual with a code of conduct violation for making a materially false statement in bad faith in the course of a grievance proceeding under this part does not constitute retaliation prohibited under this section, provided, however, that a determination regarding responsibility, alone, is not sufficient to conclude that any party made a materially false statement in bad faith.

11. **Notification of Policy.** The district will notify applicants for admission and employment, students, parents or legal guardians of students, employees, and all unions or professional organizations holding collective bargaining or professional agreements with the district of the existence of this policy. The requirement to not discriminate, as stated in Title IX and 34 C.F.R. part 106, in the district's education program(s) or activities extends to admission and employment, and inquiries about the application of Title IX and 34 C.F.R. part 106 to the district may be referred to the district's Title IX Coordinator, the Assistant Secretary for Civil Rights of the United States Department of Education, or both.

12. **Publication of Policy.** The district will prominently display on its website, if any, and in each handbook that it makes available to applicants for admission and employment, students, parents or legal guardians of students, employees, and all unions or professional organizations holding collective bargaining or professional agreements with the district, the name or title, office address, electronic mail address, and telephone number of the employee or employees designated as the Title IX Coordinator(s).

13. **Application Outside the United States.** The requirements of this policy apply only to sex discrimination occurring against a person in the United States.

14. **Scope of Policy.** Nothing herein shall be construed to be more demanding or more constraining upon the district than the requirements of Title IX (20 U.S.C. § 1681) and 34 C.F.R. part 106. To the extent that the district is in compliance with Title IX and 34 C.F.R. part 106, then all of the

district's obligations under this policy shall be deemed to be fulfilled and discharged.

Adopted on: 8/10/2020

Revised on: _____

Reviewed on: _____

KAREN A. HAASE ^{NE, IA, WY}
STEVE WILLIAMS ^{NE}
BOBBY TRUHE ^{NE, SD}



COADY H. PRUETT ^{NE, CO}
JORDAN JOHNSON ^{NE}
TYLER COVERDALE ^{SD}
SHARI RUSSELL, Paralegal

MEMORANDUM

To: KSB Policy Service Subscribers
FROM: KSB School Law
DATE: August 4, 2020
RE: Title IX Policy and Forms

As you know, the US Department of Education has made major changes in the regulations addressing how educational institutions must respond to allegations of sex harassment under Title IX. Schools must adopt revised Title IX policies no later than August 14, 2020. We have delayed in sending out this new policy in order to see if any of the several lawsuits challenging the new regulations would be successful in delaying the August 14 deadline. However, the time has come when your board must act in order to comply with the new regulations. Therefore, we have attached our suggested Title IX policy for your board's consideration.

Why is it so long? Trust us, we don't like sending you 22 page-long policies any more than you like receiving them. But the new regulations are extraordinarily detailed in what must be included in your Title IX policy. We have spent a lot of time making this policy as brief and understandable as possible. This is the end product of those efforts.

What do we have to do now? As you review this policy, there are four decisions the board will have to make for the school district:

- 1) *Decide who will serve as Title IX Coordinator(s)*

If you have been to one of our Title IX sessions, you know that the new regulations will require the district to have a Title Coordinator, a Title IX Investigator, Title IX Decision-maker, and a Title IX Appeal Officer. Of these roles, only the Title IX Coordinator is legally required to be an employee of the district. The Title IX Coordinator may serve as the investigator as well (although that may be too much of a workload for one administrator), but neither the Title IX Coordinator nor the investigator may be the same person as the decision-maker who determines responsibility at the end of the grievance process. As you will see in the policy, you are required to publish the name or title, and contact information, of your Title IX Coordinator on your website and in your handbooks. If you use KSB's full policy service including handbooks, the Title IX Coordinator is identified in your student and staff handbooks. You should make sure that this person knows that he/she has been designated as your Title IX Coordinator.

2) Decide if you want to change the burden of proof to "clear and convincing"

In section 5.7.2 on page 14 the draft policy adopts the "preponderance of the evidence" standard for Title IX investigations. The US Department of Education allows school districts the option of using a "clear and convincing" evidence standard. A preponderance of the evidence standard means that the evidence shows it is more likely than not that the accusations are true. A clear and convincing evidence standard is a higher bar of proof that requires a party to show that it is substantially more likely than not that the accusations are true. In other words, it is way harder for a school to impose consequences on a student or staff member if the district adopts the "clear and convincing" standard.

Schools are required to use the same standard for Title IX that you use for all other student discipline matters. You must also use the same standard of evidence for formal complaints against students as for formal complaints against employees, including those subject to your negotiated agreement. That means if you adopt the "clear and convincing" standard for Title IX, you'll also have to adopt it for your student code of conduct and for your negotiated agreement, which is subject to collective bargaining. We recommend against this, but if your board would like to adopt the "clear and convincing" standard, you should contact us and we will assist you in making the necessary policy revisions.

3) Decide how many days you will allow for an appeal

In section 5.8.1 on page 15 the policy provides that the parties to a Title IX investigation have 10 days in which to appeal the decision-maker's

decision. That timeline is not set by regulation and your board can make it longer or shorter if you so desire. We recommend 10 days to remain consistent with the other timeframes in the Title IX regulations. If you change this timeline, make sure it is at least as long as any timelines for review or appeal in any general complaint procedure or grievance procedure your board has adopted elsewhere in policy. Also note that if you change the 10 day appeal timeline, you will also need to change that information on the relevant forms which are included with the policy.

4) Decide if you want to make it a violation of the code of conduct to knowingly make a false statement as part of a Title IX proceeding.

The regulations allow you to have a policy that makes it a violation of the student code of conduct to knowingly make a false statement or knowingly submit false information during the Title IX grievance process or any other school investigation. If you would like to be able to impose consequences on individuals who intentionally make false allegations as part of a Title IX investigation, you will need to amend your student discipline policy to include that in the list of prohibited actions. (If you adopted the KSB Policy Update to Policy 5035 which we sent out in our first set of 2020 policy updates, you have already made this change to your student code of conduct.)

Please note that the mere fact that a respondent takes a position in the grievance process that ends up being inconsistent with the ultimate determination of responsibility will not, in and of itself, provide you a basis to impose disciplinary consequences on the respondent for intentionally making false statements as part of a Title IX proceeding. Similarly, you can't punish every complainant who makes a complaint that is ultimately found to be without merit.

What Do We Have to Do After We Adopt the Policy? After you have reviewed the policy, made the decisions above and adopted it, you cannot simply put it in your policy book and call it a day. The new regulations require you to continue to put forth a lot of effort on this policy.

1) Notice and Publication

Section 12 and 13 of the policy on page 22 sets out the notice and publication requirements that the regulations mandate. You must include this policy on your district's website, and in your staff and student

handbooks. We know that many of you have already published handbooks for the 20-21 school year. We recommend that you distribute a copy of this policy to each student and staff member with a copy of the cover letter that we have included in our sample forms. Moving forward, you will have to publish this entire policy in both your student and employee handbooks each year. Additionally, you will provide notice of this policy to the following individuals:

- ❑ All families who file option enrollment applications with the district
- ❑ All individuals who apply for employment with the district
- ❑ All unions or professional organizations holding collective bargaining or professional agreements with the district (*we have included a sample cover letter for this purpose in our forms*)

2) Training

It will be obvious to anyone who looks at this policy that your administrative team will need a lot of training on how to implement it. The policy identifies the training that the district will provide beginning on page 8 in section 5.1.4. There are several sources for this training. KSB is developing modules of online training which staff can access on demand, and which will generate an appropriate “certification” at each level which your district can keep on file. To register for the training being offered by KSB, [click here](#). However, we are not the only source of training. [Several entities, including NCSA](#), have held or will be holding virtual workshops on specific dates this fall, and other opportunities for training will be provided.

The new regulations specifically require you to train three groups of people:

a. Title IX Coordinators

The employee or employees who will serve as your Title IX Coordinator have always needed frequent training. The new regulations add several things about which Title Coordinators must be trained.

b. Title IX Investigators

Anyone who will investigate Title IX complaints on the district’s behalf must receive the same training that Title IX Coordinators

receive. They also must specifically be trained on the legal standards of “relevance,” “privilege,” and “burden of proof/burden of production.” Finally Title IX Investigators must be trained on how to write compliant Title IX investigation reports.

c. Title IX Decision-Makers

Anyone who will decide the outcome of Title IX grievances must receive the same training that Title IX Coordinators. They must have additional specific training on the legal standards of “relevance,” “privilege,” and “burden of proof.” Finally, Title IX Decision Makers must be trained on writing Title IX decisions.

Although the regulations don’t *specifically* require it, it will be impossible for your district to comply with the new regulations unless it provides training to a fourth group from your school community:

d. All staff and board members

Under the new regulations, **any employee or agent of the school district** who is aware of possible sexual harassment can create liability for the district if that staff member does not immediately report that harassment. We do not see any way to ensure that this obligation is addressed unless you train every staff member (including classified staff and community coaches) and every board member on how to identify and report sexual harassment.

If you have ALICAP as your school’s insurer, you may be able to access a general training for your staff (but not your admins) through Safe Schools. Regardless of the source of your training, be sure that the vendor (1) allows you to post all of the training materials on your website; (2) maintains records of all the training received for at least 7 years; and (3) includes all of the legally-required elements of the training contained in the new regulations.

So did you put every possible item into the policy? Actually we didn’t. The new regulations require colleges to allow in-person questioning of the victim and the respondent by the other party. The regulations say that this is also permitted but not required in a K-12 setting. We cannot fathom a kindergartner being cross examined by another student or parent, so we have omitted that from this policy.

Did you mention forms? Yes, we have attached a flowchart that illustrates the Title IX complaint process. At each stage of the process, we have linked to sample forms that the district can use in implementing this policy.

Any other policy changes this time around? Just a couple. This policy replaces 4014 and 5026, so those will now be “intentionally left blank.” We have also made minor edits to Policy 2006 to make the timelines in that policy match those in the new policy and to also make it clear that some but not all complaints about sex harassment are covered by the Title IX policy.

Handbook Updates. As discussed above, we know that many of you already printed and/or distributed your handbooks and will use the form cover letter to send students and staff the new policy as an effective addendum to the handbooks you published.

Some schools have been waiting to complete handbook updates, so we updated our form handbooks to include the new Title IX policy and to reflect revisions to Policy 2006. We have added the Title IX redline changes to the existing redline versions from our first round of updates from earlier this summer. Some subscribers may have made those changes, and if so you can ignore them. But this way you’ll have all of the proposed changes together.

Our form handbooks, including the redline versions, are only available to our Complete Policy Service Subscribers. They can be accessed only on the “Complete” service page, as usual. If you are not a KSB Complete Service subscriber, you should consult with one of the KSB attorneys or your district’s attorney to incorporate the handbook updates and ensure they are modified and distributed as required.

CONCLUSION

We know that you did not run for the board or get into school administration to read legal gobbledegook. We have tried hard to take extremely complicated and detailed regulations and boil them down. However, you will almost certainly have questions arise about the new Title IX requirements. We will provide more information about our online training in the next few days.

As always, please feel free to contact any of us if you have questions about any of these policy changes. Our group e-mail address is ksb@ksbschoollaw.com.

EEGAN SUPPLY CO.

"It's Service After The Sale That Counts"

13838 Industrial Road • Omaha, NE 68137

PRICE QUOTE

Phone 402-346-0597

Fax 402-346-5076

Page 1

Printed 07/09/20 MP

Quoted
Madison Public Schools Attn: Accounts Payable P.O. Box 450 700 S. Kent Madison NE 68748 Tel: 402-454-3336 Fax: 402-454-2238

Ship To
MADISON PUBLIC SCHOOL 700 SO KENT MADISON NE 68748

Quote # Q029093	Quote Date 07/09/2020	Exp Date 09/07/2020	Customer # 0363301	Customer P/O #	Ship Via	Writer MP
Job ID			Customer Terms Net 30 Days		Salesman Donavon Bjorklund	

Product	Description	UM	Quant	Unit Price	Extension
	***** * MUST HAVE SIGNATURE!! * *****				
KP-KP16-20D	KODIAK K16 SERIES 20" DISK SCRUBBER TRACTION DRIVE	EA	1	5859.51	5859.51
KP-KP16-26D	KODIAK K16 SERIES 26" DISK SCRUBBER	EA	1	6811.80	6811.80
KP--KP16-28D	KODIAK K16 SERIES 28" DISK SCRUBBER	EA	1	7105.68	7105.68

X: _____ (Accepted by)	
---------------------------	--

MESSAGE	TERMS



Under The Hood

Affordable Performance and Durability





WALK-BEHIND SCRUBBERS RANGE
K11 | K16 | K25



Unleash Your Full Cleaning Potential

Phone: 262-833-4025 Toll Free: 855-965-0011 www.kodiakequip.com



Proudly
Assembled
In USA

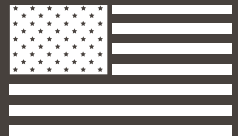

PICK THE CHASSIS



**Small
K11** Available Summer 2020

Clean in hard to reach areas with this small-footprint walk behind floor scrubber. Nimble enough to clean congested areas with ease.

- Up to 50,000 sqft Per Charge
- 11 / 12 Gallons
- 17 - 20 inch decks

Applications

- Fabrication Shops
- Auto-Truck Dealers
- Machine Shops



**Medium
K16**

Keep every area of your facility clean with this mid-sized walk behind scrubber. This easy to maneuver design provides versatility on a durable platform.

- Up to 80,000 sqft Per Charge
- 16 / 16 Gallons
- 20 - 28 inch decks

Applications

- Warehouses
- Food Packaging



**Large
K25**

Reduce your cost to clean with a larger walk behind scrubber. Clean large open areas simply and with predictable results.

- Up to 110,000 sqft Per Charge
- 25 / 26 Gallons
- 24 - 32 inch decks

Applications

- Beverage Distribution
- Sports Arena
- Aviation

Size Comparison Chart

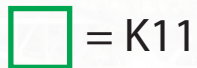

= K11

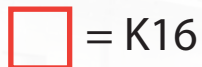

= K16

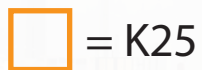

= K25

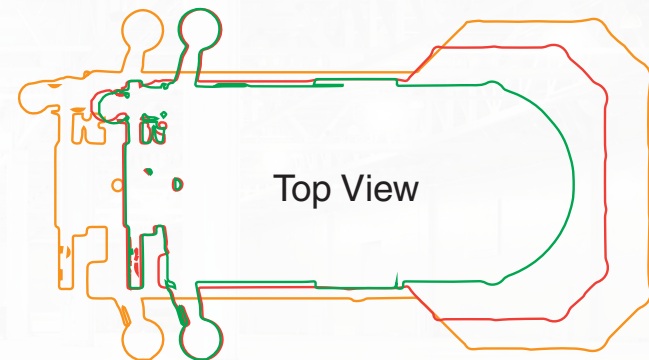
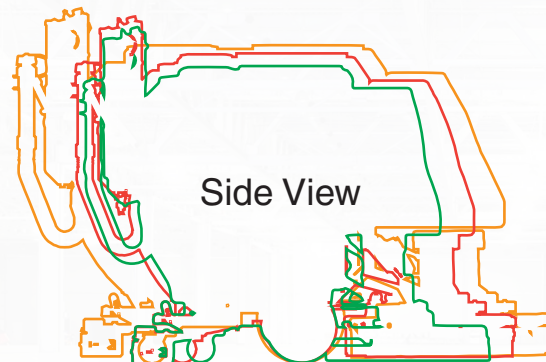

Specifications and features subject to change without notice.

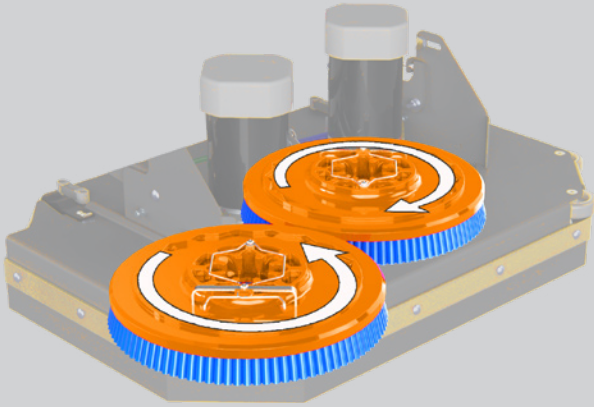

Disk

Benefits

- Brush / Pad Selection
- Lowest Maintenance Cost
- Improved Cleaning on Irregular Floors
- Brushes Individually Driven for Unmatched Performance

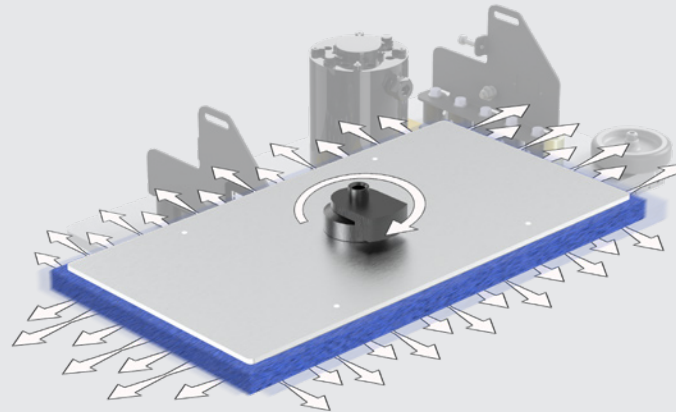

Orbital

Benefits

- Chemical Free Stripping
- Reduce Slip & Fall Potential
- 70% Reduction in Water Usage
- Consistent Results - No Swirl Marks
- VCT Prep & Recoat

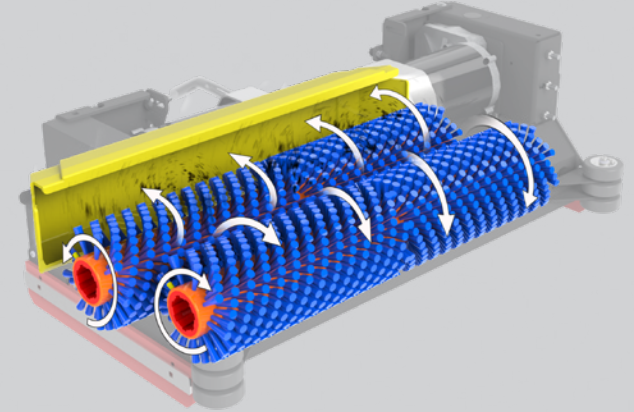

Cylindrical

Benefits

- Eliminates Dust Mopping
- Scrub & Sweep Simultaneously*
- Superior Tile & Grout Cleaning
- Excellent on Rubber Surfaces
- Great for Indoor Track Fields

*K11 Cylindrical Deck will have a single brush and no hopper.



26 in Disk Deck on K16 Chassis Shown



24 in Orbital Deck on K16 Chassis Shown



26 in Cylindrical Deck on K16 Chassis Shown

LOOK INSIDE

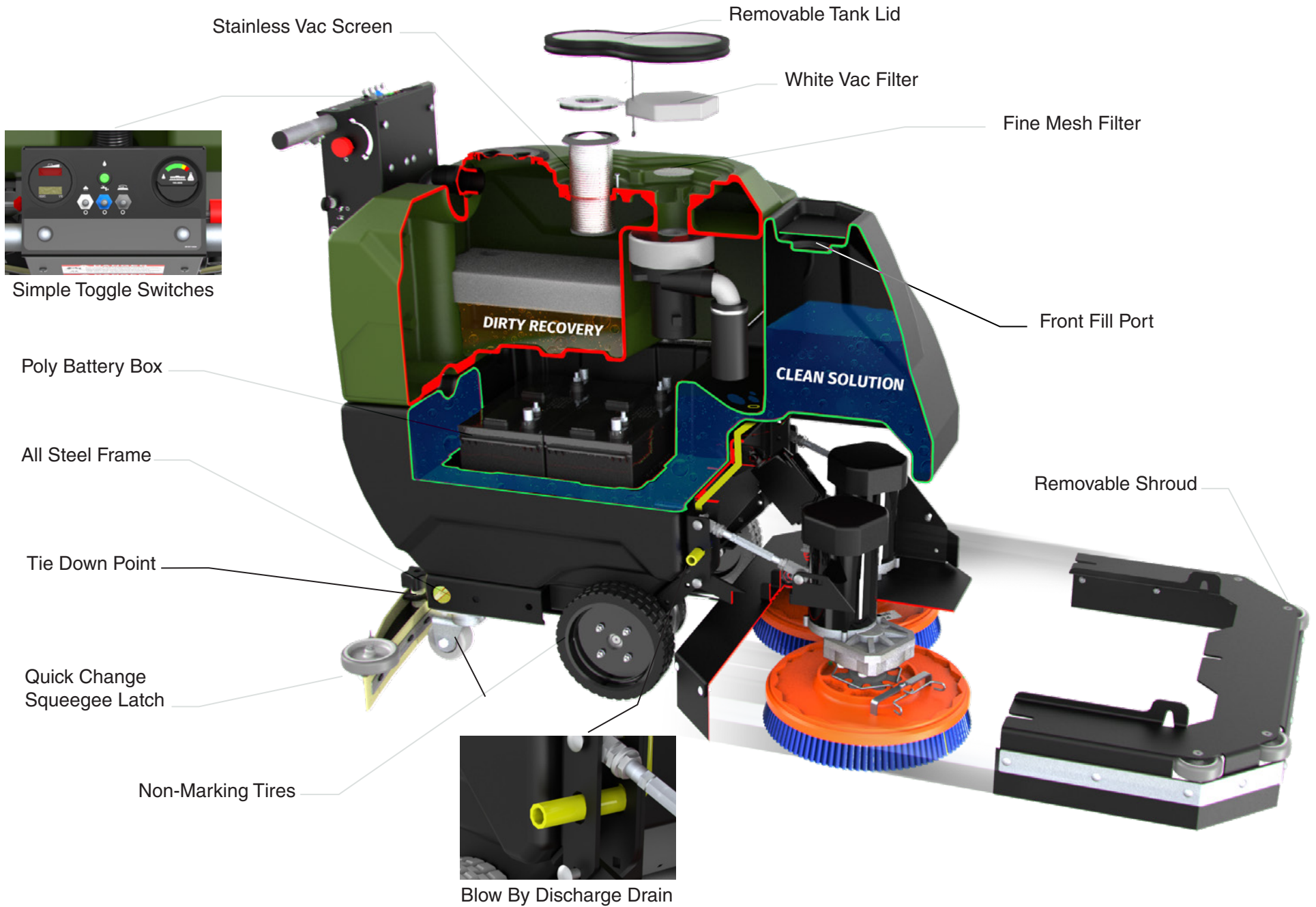

PICK THE OPTIONS



Drain Savers & Deluxe Fill Options

Conveniently fill the floor scrubber fresh water tank from any standard faucet with the 60 inch retractable hose. Drain saver basket keep your Recovery tanks debris free, and simple to remove for disposal.



Onboard Charger

Charge anywhere in the facility with a plug and forget charger. LED Indicator lights shows state of charge and historic charge cycle data can be downloaded for review.



WET / AGM Battery Options

Choose between a variety of battery options for optimal run and charge times based on the application and needs.



Hand Guards

Protect operators with heavy duty hand guards.



Small Available
K11 Summer 2020

Medium
K16

Large
K25

SPECIFICATIONS



Small K11 *Available Summer 2020*

Disk Scrub Path:	17 & 20 in 43 & 51 cm
Cylindrical Path:	24 in 61 cm
Orbital Path:	20 in 51 cm
Dimensions (LxWxH):	49.5 x 22.5 x 38 in* 125 x 64 x 96 cm*
Solution Tank:	11 Gal 41 L
Recovery Tank:	12 Gal 45 L
Demisting Chamber:	1 Gal 4 L
Run Time:	Up to 2.5 Hours*
Theoretical Coverage:	50,000 sqft/charge* 4,645 sqm/charge*

*Based on continuous scrubbing run times, standard batteries, low down pressure and all options off.

*Coverage is based off of ISSA 2010 Cleaning Times



Medium K16

Disk Scrub Path:	20, 26 & 28 in 51, 66 & 71 cm
Cylindrical Path:	26 in 66 cm
Orbital Path:	24 & 28 in 61 & 71 cm
Dimensions (LxWxH):	53 x 29 x 38.5 in* 135 x 74 x 98 cm*
Solution Tank:	16 Gal 60 L
Recovery Tank:	16 Gal 60 L
Demisting Chamber:	2 Gal 8 L
Run Time:	Up to 3 Hours*
Theoretical Coverage:	80,000 sqft/charge* 7,432 sqm/charge*

*Based on continuous scrubbing run times, standard batteries, low down pressure and all options off.

*Coverage is based off of ISSA 2010 Cleaning Times



Large K25

Disk Scrub Path:	28 & 32 in 71 & 81 cm
Cylindrical Path:	26 & 30 in 66 & 76 cm
Orbital Path:	24 & 28 in 61 & 71 cm
Dimensions (LxWxH):	62 x 33 x 39.5 in* 157 x 84 x 100 cm*
Solution Tank:	25 Gal 95 L
Recovery Tank:	26 Gal 98 L
Demisting Chamber:	2.5 Gal 9 L
Run Time:	Up to 3.5 Hours*
Theoretical Coverage:	110,000 sqft/charge* 10,219 sqm/charge*

*Based on continuous scrubbing run times, standard batteries, low down pressure and all options off.

*Coverage is based off of ISSA 2010 Cleaning Times

Specifications and features subject to change without notice.



Kodiak - Since 1986, Cleaning The World One Warehouse At A Time

The **Kodiak** brand was engineered from the ground up with heavy-duty, industrial cleaning in mind. The filthiest factory or the grimeiest warehouse stands little chance against these scrubbers which are built to cruise through the toughest job. Our design intent wasn't only focused on a durable machine that can withstand the day to day hardships, but also to keep things simple for your budget. Using simple switches and common fasteners, our machines come at a low-cost point, and are easy to maintain.

RPS Corporation is a family owned business based in Racine, Wisconsin manufacturing some of the world's most reliable cleaning equipment. We strive to prove the highest value in machines and local support with a network of 425 distributors in over 42 countries.

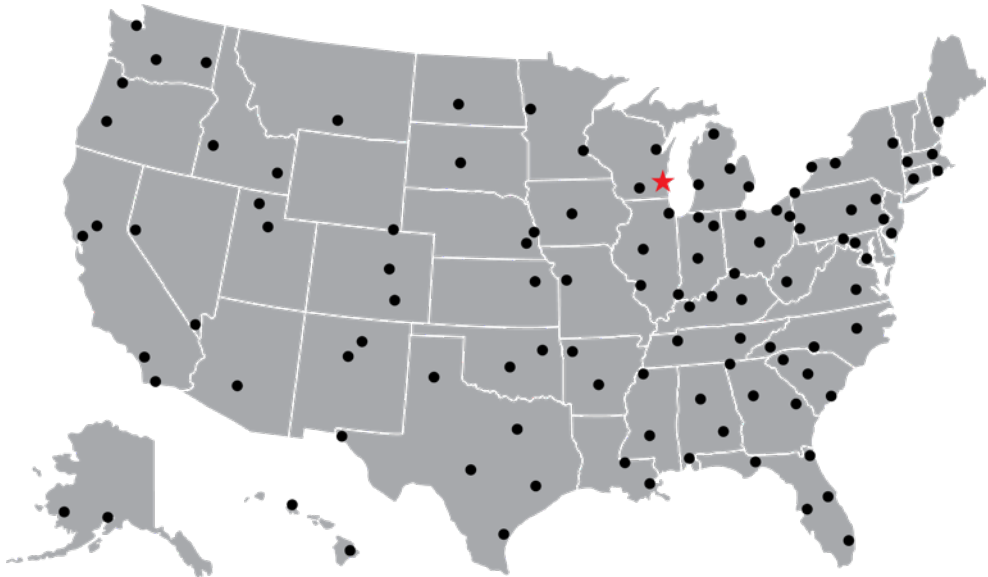

★ RPS HQ

● Distributors

Real People On The Phones Here To Help



Same Day Shipping On Parts Orders



Join The Club And Start Cleaning Today!



CONNECT WITH KODIAK

Authorized Distributor

Phone: 262-833-4025
Toll Free: 855-965-0011
www.kodiakequip.com



Call For A Free Demo!

Manufactured By:
RPS Corporation
1711 South Street
Racine, Wisconsin, 53404 (USA)





Photo
Walk-be

Dealer Information:		Customer Co	
MH Equipment		MADISON	
3715 WEST OLD POTASH HWY		700 SOU	
GRAND ISLAND NE. 68803		P	
		MADISON NE.	
Work Phone:	308-382-3585	Work Phone:	402-454-33
Cell Phone:	402 676 0119	Cell Phone:	
Fax:		Fax:	402-454-22
Email:	jschuneman@mhequipment.com	Email:	cflsinger@es

Specifications:	Dimensions:
------------------------	--------------------

Maximum coverage:	34,445 sq ft/ hr	Width:
Scrub path:	24 in	Width with squeegee:
Working speed:	3 mph	Weight:
Squeegee width:	37.4 in	Weight wet including battery:
Brushes:	(2) 24" cylindrical	Quote Number:
Solution tank:	19 gal	
Recovery tank:	19.5 gal	
Battery pack:	(4) 6V 240 AH	
Battery charger:	on board	

Warranty - Travel - Ninety Days, Labor - Three Years, Parts/Replacement Parts - Five Years
 Batteries & Industrial Batteries - 0-3 months Replacement; One year Prorated, Charger - One Year
 Extended Warranties Available

Machine Price	PHX24CQP	List price \$12,300
Option #	Description	
	Onboard Charger 115V	Included
7022	Cylindrical Brush Set (2 required)	Included
956751	240AH Batteries (4 required) Trojan Upgrade	Included
	THIS IS A INDUSTRIAL SWEEPER SCRUBBER UNIT.	



	Free Local delivery	Included
	Free Operator training	Included
	(LEASE OPTIONS AVAILABLE)	
	MH Equipment PROMO Price	\$9,950.00



Tax Not Included • This Quote Is Valid for 30 days

enix 24

Behind Scrubber

Contact Information:

WYOMING PUBLIC SCHOOL

1000 W KENT STREET

PO BOX 450

68748

36

38

[wy8.org](http://www.wy8.org)

28 in
37.4 in
375 lbs.
816 lbs



Var. Tanks - 10 Years

QUOTE NUMBER 08062020





Customer Signature Date



Specifications	Phoenix 24	Phoenix 26	Phoenix 28
Working width	24 in (60 cm)	26 in (65 cm)	28 in (71 cm)
Squeegee width	37.4 in (95 cm)	37.4 in (95 cm)	43 inch (109 cm)
Theoretical area of performance	34,445 ft ² /hr (3,200 m ²)	34,445 ft ² /hr (3,200 m ²)	37,673 ft ² /hr (3,500 m ²)
Actual area of performance	23,680 ft ² / hr (2,200 m ²)	25,640 ft ² /hr (2,382 m ²)	28,000 ft ² /hr (3,200 m ²)
Working speed	3 mph (5 km per hr)	3.1 mph (5 km per hr)	3.1 mph (5 km per hr)
Rated voltage	24 volts	24 volts	24 volts
Vacuum cfm	65 cfm	65 cfm	65 cfm
Vacuum waterlift	65 inches (165 cm)	65 inches (165 cm)	65 inches (165 cm)
Vacuum HP	.42 HP	.42 HP	.42 HP
Drive motor HP	.40 HP	.40 HP	.70 HP
Brush Type	Cylindrical	Disc	Cylindrical
Brush motor(s) HP	1 HP	.75 HP (2)	1.2 HP
Number of brushes	2	2	2
Brush diameter	24 in (60 cm)	26in (65 cm)	28in (71 cm)
Brush RPM	850 RPM	180 rpm	850 RPM
Aqua-Stop Equipped	N/A	Yes	N/A
Solution capacity	19 Gal (72 liters)	22.5 Gal (85 liters)	22.5 Gal (85 liters)
Recovery capacity	19.5 Gal (74 liters)	22.5 Gal (85 liters)	22.5 Gal (85 liters)
Dry Weight	375 lbs. (170 kg)	570.6 lbs (258.5 kg)	570.6 lbs (258.5 kg)

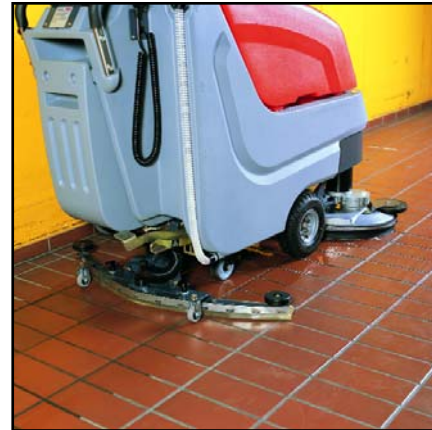

PowerBoss is proud to be BLUE!
What does it mean to be BLUE?

- **Water Conservation** – Aqua-Stop saves water usage by 50%, water is released through a pump system providing greater control of water usage than gravity systems
- **Clean Air** - High-performance filter system dramatically reduces the release of dust and debris back into the air, dust vacuum ensures that dust is put directly into the hopper, bristle pattern on main broom increases dust control
- **Lower Emissions** – All gas and LP engines meet Tier 2 specifications, catalyst mufflers, battery operated available, diesel operated available, bio-diesel fuel can be used in Kubota engine
- **Safer Work Environment** – Orange machines are highly visible to others in the workplace, simple controls reduce operator error, one-button scrub, horn, fire in hopper indicator, effective braking system, “belly bar” prevents operator from being pinned behind machine when in reverse, parabolic squeegee picks up all water leaving the scrub path virtually dry for traffic, seat equipped with safety shut-off switch, also available: overhead guard, back-up alarm, warning beacon
- **Clean Energy** – Battery operated available, bio-diesel fuel can be used in Kubota engines
- **Lower Chemical Reliance** – Aqua-Stop saves chemical usage by 50%, pump system for water and chemical release allows for better control of chemical usage, chemical metering system is available as an option and regulates chemical usage to the correct dose

Features listed are general for PowerBoss equipment; each machine has different features and therefore, may or may not fill all of the features listed above.



PowerBoss, Inc.
175 Anderson Street Aberdeen, NC 28315
Phone: 910-944-2105 Fax: 910-944-7409
A Member of the Hako Group

Come Visit our Website at
www.powerboss.com

Phoenix 24, 26 & 28
Walk-Behind Scrubbers

Easy handling, superb performance, environmentally-friendly.

Performance:

- The Phoenix 24 and 28 have cylindrical brush decks with integrated sweeping function. The cylindrical deck is made of corrosion-resistant aluminum casting.
- The Phoenix 26 is a disc model equipped with Aqua-Stop
- Two powerful brush motors guarantee an even cleaning result across the entire width of the machine.
- The direct Brush Release System (**BRS**) allows brushes to be changed quickly.
- Battery running time to suit the application, on-board charger standard.
- Phoenix 24 has a 19 gal solution tank and a 19.5 gal recovery tank.
- Phoenix 26 and 28 have a 22.5 gal solution tank and a 22.5 gal recovery tank.
- Flow-optimized dirty water tank with **AFS** (Anti Foam System) to protect the vacuum turbine. Large tank lid provides easy access for cleaning purposes.
- A new kind of squeegee with Quick Adjust System allows optimum pickup even on difficult floors. Quick-clamping device for squeegee makes replacement easier. Squeegee blade is highly-resistant to wear.



Phoenix 24 and 28



Phoenix 26

Low brush deck is ideal for cleaning underneath obstacles.



Squeegee provides optimum pick-up of dirty water, making the floor traffic-ready almost immediately.



Large tank lid provides access for easy clean out.



Large tank opening allows for fast fill and automatic filling systems.



Easy access to the batteries and drive system for service and maintenance.



Simplified and easy-to-understand operator controls.

Comfort:

- Easy, ergonomic operation as a result of the compact, maneuverable construction.
- Simple, easy-to-understand controls ensure that the machine is easy to use and maintain
- Ergonomic, adjustable speed regulation.
- Ergonomic hand bails offer great control of the machine.
- Designed to give the operator more room for their feet while operating the Phoenix 24, 26 or 28.
- Designed to give the operator an excellent line of sight to the area that needs to be cleaned.

Convenience:

- Low brush deck is ideal for cleaning underneath obstacles such as skids, warehouse racks and other stationary objects.
- Large tank opening in clean water tank saves time when filling using automatic filling systems. Run time and tank filling are in tune with each other.
- Service-friendly access to batteries and drive.
- "Silencer" option means significant noise reduction.
- On-board charger is convenient and allows you to charge the Phoenix 24, 26 or 28 anywhere.