



## KIMBALL PUBLIC SCHOOLS

Administration Offices  
901 South Nadine Street  
Kimball, NE 69145

---

### AGENDA

The following is the agenda for the meeting of the Board of Education to be held on Monday, February 12, 2024, at 6:30 PM in the Kimball County Transit Service Meeting Room, 233 South Chestnut Street, Kimball, Nebraska 69145

1. Pledge of Allegiance
2. Call meeting to order (Open Meeting Law announcement)
3. "The Mission of Kimball Public Schools is to educate every student for a lifetime of success."
4. Roll Call
5. Excuse the Absence of Board Member
6. Approval of Agenda
7. Read and Approval of Minutes: Regular Board Meeting January 8, 2024, and Board Work Session January 24, 2024
8. Reading and Approval of Board Bills
9. Treasurer's Report
10. Board Reports
11. Administrator's Reports
12. Superintendent's Report
13. Director Report: Matt Brown - Building and Grounds Director and Waylon Lewis - Transportation Director
14. Presentation: Amy Trauernicht (Cognia)
15. Recognition of Visitors - Public Comment (Policy 202.05)
16. Action Items:
  - 16.A. Discuss, consider and take all necessary action with regard to approval of CNC Plasma Table quote
  - 16.B. Discuss, consider and take all necessary action with regard to approval of LED lighting fixture quote
  - 16.C. Discuss, consider and take all necessary action with regard to approval of LED light fixture installation quote
  - 16.D. Discuss, consider and take all necessary action with regard to approval of asphalt quote
  - 16.E. Discuss, consider and take all necessary action with regard to approval of ceiling tile quote
  - 16.F. Discuss, consider, and take all necessary action in regard to approval of football stadium scoreboard quote
  - 16.G. Discuss, consider and take all necessary action with regard to review of board policies: 701.19, 701.20, 701.21, 701.22, and 701.23.
17. Discussion Items:
  - 17.A. Discussion Item #1: School Calendar for the 2024-25 School Year

18. Next Meeting(s)/Opportunities:

18.A. Regular Board Meeting: Monday, March 11, 2024 at 6:30 PM in the Meeting Room at the Kimball County Transit Service, 233 South Chestnut Street, Kimball, Nebraska

19. Motion to Adjourn

NOTICES:

**COPY OF OPEN MEETINGS ACT:** The Board of Education makes available at least one current copy of the Open Meetings Act posted in the meeting room at a location accessible to members of the public. The Act is posted on the south wall of the meeting room.

**KIMBALL PUBLIC SCHOOLS MISSION STATEMENT:** “The Mission of Kimball Public Schools is to educate every student for a lifetime of success.”

**NOTICE OF MEETING:** Notice of the meeting was published according to Board Policy.

**INSTRUCTIONS FOR THOSE WHO WISH TO SPEAK DURING PUBLIC FORUM:**

Getting Started: When it is your turn to speak during the public forum portion of the agenda, please come forward to the podium situated next to the Board, sign your name and information on the sign-in sheet. Any member of the public desiring to address the board shall be required to identify himself or herself, including address and the name of any organization represented by such person unless the address requirement is waived to protect the security of the individual

Time Limit: You may speak only one time and must limit comments to 5 minutes or less. Public Forum will not exceed 30 minutes.

Personnel or Student Topic: If you are planning to speak about a personnel or student matter involving an individual, please understand that our policies require such concerns initially be directed to the administration for consideration. Board members will generally not respond to any questions you ask or comments you may make about individual staff members or students. You are cautioned that slanderous comments are not protected just because they are made at a Board meeting.

General Rules: Please remember this is a public meeting for the conduct of the business of the Board of Education. Offensive language, personal attacks and hostile conduct will not be tolerated.

**CLOSED SESSIONS:** Kimball Public Schools Board of Education reserves the right to go into closed session in accordance with Nebraska Statue 84-1410.

BY: KIMBALL PUBLIC SCHOOLS

A meeting of the Board of Education of Kimball Public Schools was convened in open and public session on Wednesday, January 24, 2024 at 6:30 PM in the Kimball County Transit Service Meeting Room, 233 South Chestnut Street, Kimball, Nebraska 69145.

A notice of the meeting was given in advance by publication and/or posting in accordance with the Board approved method for giving notice of meetings. Notice of this meeting was given in advance to all members of the Board of Education. The secretary for the Board maintains a list of the news media, of the time and place of the meeting and the subject to be discussed at the meeting. Availability of the agenda was communicated in the publicized notice. All proceedings of the Board of Education except as may be hereinafter noted were taken while the convened meeting was open to the attendance of the public.

The Pledge of Allegiance was stated by all present.

The meeting was called to order by President Travis Cook at 6:30 p.m. At the beginning of this meeting the President announced and informed the public that a current copy of the Open Meetings Act is posted on the wall of the meeting room and directed the public to its location. Board Member Cook read the mission statement of Kimball Public Schools.

The roll was called and the following Board members were present or absent.

**Present:** Travis Cook, Jennifer Griebel, Tom O'Brien, Ken Smith, Britni Toth, **Absent:** Lanny Little.

Motion was made by Tom O'Brien, seconded by Jennifer Griebel to excuse the absence of Lanny Little. After discussion and upon roll call vote, the Board voted as follows:

Lanny Little: Absent  
Travis Cook: Aye  
Jennifer Griebel: Aye  
Tom O'Brien: Aye  
Ken Smith: Aye  
Britni Toth: Aye

Motion was made by Britni Toth, seconded by Jennifer Griebel to approve the agenda. After discussion and upon roll call vote, the Board voted as follows:

Lanny Little: Absent  
Travis Cook: Aye  
Jennifer Griebel: Aye  
Tom O'Brien: Aye  
Ken Smith: Aye  
Britni Toth: Aye

The Board reviewed the current KPS mission and vision statements as part of the KPS continuous improvement process.

The Board reviewed current goals and identified the following goals for 2024:

The Board reviewed the current Capital Improvement projects schedule and identified projects to complete in 2024.

The Board discussed the current strategic plan that runs through 2024 and discussed the next steps in updating the strategic plan.

Motion was made by Ken Smith, seconded by Britni Toth to adjourn the meeting at 9:40 p.m. After discussion and upon roll call vote, the Board voted as follows:

Lanny Little:	Absent
Travis Cook:	Aye
Jennifer Griebel:	Aye
Tom O'Brien:	Aye
Ken Smith:	Aye
Britni Toth:	Aye

ATTEST:

TRAVIS COOK  
KIMBALL PUBLIC SCHOOLS  
BOARD OF EDUCATION

THOMAS O'BRIEN  
KIMBALL PUBLIC SCHOOLS  
BOARD OF EDUCATION

A meeting of the Board of Education of Kimball Public Schools was convened in open and public session on Monday, January 8, 2024 at 6:30 PM in the Kimball County Transit Service Meeting Room, 233 South Chestnut Street, Kimball, Nebraska 69145.

A notice of the meeting was given in advance by publication and/or posting in accordance with the Board approved method for giving notice of meetings. Notice of this meeting was given in advance to all members of the Board of Education. The secretary for the Board maintains a list of the news media, of the time and place of the meeting and the subject to be discussed at the meeting. Availability of the agenda was communicated in the publicized notice. All proceedings of the Board of Education except as may be hereinafter noted were taken while the convened meeting was open to the attendance of the public.

The Pledge of Allegiance was stated by all present.

The meeting was called to order by President Travis Cook at 6:30 p.m. At the beginning of this meeting the President announced and informed the public that a current copy of the Open Meetings Act is posted on the wall of the meeting room and directed the public to its location.

Board Member Little read the mission statement of Kimball Public Schools.

The roll was called and the following Board members were present or absent.

**Present:** Travis Cook, Jennifer Griebel, Lanny Little, Tom O'Brien, Ken Smith, Britni Toth.

Board President Cook designated authority to Superintendent Anderson to begin nominations for the Board President.

Board President- Lanny Little, seconded by Ken Smith nominated Travis Cook for President. Motion was made by Lanny Little, seconded by Britni Toth that all nominations cease. Motion carried 6-0. Travis Cook was elected President 5-0.

Following the nomination of Travis Cook as the Board President, Superintendent Trevor Anderson presented the gavel to Cook and the Board President led the nominations for other board officer positions.

Board Vice President- Ken Smith nominated Jen Griebel for Vice President and Lanny Little seconded it. Motion was made by Tom O'Brien, seconded by Britni Toth that all nominations cease. Motion carried 6-0. Jennifer Griebel was elected Vice President 5-0.

Board Secretary-Travis Cook seconded by Britni Toth nominated Tom O'Brien for Board Secretary. Motion was made by Lanny Little, seconded by Jen Griebel that all nominations cease. Motion carried, 6-0. Tom O'Brien was elected Secretary 5-0.

Board Treasurer – Jen Griebel, seconded by Travis Cook nominated Ken Smith for Treasurer. Motion was made by Lanny Little, seconded by Tom O'Brien that all nominations cease. Motion carried, 6-0. Ken Smith was elected Treasurer 5-0.

Motion was made by Tom O'Brien, seconded by Lanny Little to approve the agenda. After discussion and upon roll call vote, the Board voted as follows:

Travis Cook: Aye

Jennifer Griebel: Aye

Lanny Little: Aye

Tom O'Brien: Aye

Ken Smith: Aye

Britni Toth: Aye

Motion was made by Ken Smith, seconded by Jennifer Griebel to approve the minutes from the Regular Board Meeting December 11, 2023. After discussion and upon roll call vote, the Board voted as follows:

Travis Cook: Aye

Jennifer Griebel: Aye

Lanny Little: Aye

Tom O'Brien: Aye

Ken Smith: Aye

Britni Toth: Aye

Motion was made by Lanny Little, seconded by Jennifer Griebel to approve the current bills. After discussion and upon roll call vote, the Board voted as follows:

Travis Cook: Aye

Jennifer Griebel: Aye

Lanny Little: Aye

Tom O'Brien: Aye

Ken Smith: Aye

Britni Toth: Aye

**Kimball Public Schools  
BOARD REPORT OF EXPENDITURES  
1/8/2024**

61977	CARD SERVICES		\$	9,911.10
		<b>PREPAID</b>		
				<hr/>
				<b>\$9,911.10</b>

**REGULAR MONTHLY EXPENSES**

61989	AG PARTS WORLDWIDE	63.80
61990	APPLE INC	299.00
61991	BERGANKDV,LTD	201.60
61992	BLACK HILLS ENERGY	1,539.68
61993	CAPITAL BUSINESS SYSTEMS, INC.	8,276.88
61994	CAPITAL BUSINESS SYSTEMS, INC.	114.36
61995	CENTURY LINK BUSINESS SERVICES	293.58
61996	CITY OF KIMBALL	11,155.50
61997	COMPUTER INFORMATION CONCEPTS	3,140.00
61998	CULLIGAN	105.80
61999	DAS STATE ACCOUNTING - CENTRAL	535.26
62000	DOANE UNIVERSITY	100.00

62001	DWF DENVER	132.49
62002	ESU COORDINATING COUNCIL	990.00
62003	FRANK PARTS COMPANY	93.59
62004	FRENCHMAN VALLEY COOP	787.75
62005	GRANITE TELECOMMUNICATIONS	792.50
62007	IDEAL/BLUFFS FACILITY SOLUTIONS	195.02
62008	INFINITE CAMPUS	3,140.00
62009	JOHNSON CONTROLS	1,274.89
62010	KIMBALL ACE HARDWARE	299.72
62011	KIMBALL AUTO PARTS CO	271.09
62012	KIMBALL PUBLIC SCHOOLS	928.96
62013	LINCOLN MARRIOTT CORNHUSKER	111.00
62014	MENARDS - SCOTTSBLUFF	112.67
62015	MONUMENT CLEANING COMPANY	6,005.00
62016	NE COLORADO CELLULAR, INC	98.60
62017	NE COUNCIL OF SCHOOL ADMINISTRATORS	190.00
62018	NEBRASKA SAFETY AND FIRE EQUIPMENT,	1,438.10
62019	ONE SOURCE	54.00
62020	PANHANDLE COOP ASSOCIATION	2,346.09
62021	PERRY, GUTHERY, HAASE & GESSFO	345.60
62022	SANDBERG IMPLEMENT	89.50
62023	SPARQ DATA SOLUTIONS, INC	4,316.00
62024	STAPLES BUSINESS ADVANTAGE	1,639.60
62025	VERIZON WIRELESS	52.93
62026	VINCE'S CORNER	196.73
62027	VOYAGER FLEET SYSTEMS, INC.	1,193.14
62028	WESTERN NEBRASKA OBSERVER	358.43
62029	WOLF AUTOMOTIVE CENTER	621.33
62030	WYOMING DEPARTMENT OF TRANSPORTAT	10.00
62031	BLACK HILLS ENERGY	3,495.32

<b>GENERAL FUND TOTAL</b>	<b>57,405.51</b>
---------------------------	------------------

6233	CASH-WA DISTRIBUTING	8,200.65
6234	HILAND DAIRY FOODS COMPANY, LLC	1,706.40
6235	PEPSI-COLA OF WESTERN NEBRASKA	1,656.70
6236	US FOODS - GRAND ISLAND	8,197.97
6237	WESTERN NEBRASKA OBSERVER	128.50

<b>NUTRITION FUND TOTAL</b>	<b>\$ 19,890.22</b>
-----------------------------	---------------------

1260	KIDWELL	247.50
------	---------	--------

<b>DEPRECIATION FUND</b>	<b>\$247.50</b>
--------------------------	-----------------

1557	KIMBALL PUBLIC SCHOOLS	3,794.71
1558	MOHR RANCH AND CONSTRUCTION	465.89

<b>BUILDING FUND</b>	<b>\$4,260.60</b>
----------------------	-------------------

<b>TOTAL MONTHLY BILLS</b>	<b>\$81,803.83</b>
----------------------------	--------------------

Motion was made by Tom O'Brien, seconded by Britni Toth to approve the Treasurer's Report. After discussion and upon roll call vote, the Board voted as follows:

Travis Cook:	Aye
Jennifer Griebel:	Aye
Lanny Little:	Aye
Tom O'Brien:	Aye
Ken Smith:	Aye
Britni Toth:	Aye

January 8, 2024

Treasurer's report is as follows:	Jan-24	Jan-23
Amount received from County Treasurer	70,743.94	69,202.92
Bank Balance                      December 29, 2023	312,632.14	128,419.46
Savings Account General Funds      December 29, 2023	1,784,093.89	1,821,588.62
Depreciation Fund                      December 29, 2023	394,887.94	565,076.18
Building Fund                              December 29, 2023	528,696.83	1,011,846.01
Nutrition Fund                            December 29, 2023	85,575.53	111,393.12
Activity Fund                                December 29, 2023	112,450.41	86,812.45
Total Available Funds	3,218,336.74	3,725,135.84
Payroll Gross	330,647.41	308,203.37
Amount of Bills	81,803.83	94,721.22
Blue Cross Blue Shield/HSA Pmt/UNUM Life	90,807.62	72,544.79

Nebraska School Retirement	31,312.59	29,431.66
FirsTier Bank (FICA)	24,733.86	22,899.59
Total Amount of Expenses	559,305.31	527,800.63
Balance Remaining after Expenses	2,659,031.43	3,197,335.21

The Board reviewed written reports of Mrs. Danielle Reader, Jr-Sr High School Principal and Mrs. Amanda Culek, Mary Lynch Elementary Principal.

The Board reviewed the written report of Mr. Trevor Anderson, superintendent. Motion was made by Lanny Little, seconded by Tom O'Brien to approve the appointment of Board Committees: American Civics, Building & Grounds/ Transportation, Finance, Negotiations, & Scholarships. After discussion and upon roll call vote, the Board voted as follows:

- Travis Cook: Aye
- Jennifer Griebel: Aye
- Lanny Little: Aye
- Tom O'Brien: Aye
- Ken Smith: Aye
- Britni Toth: Aye

Motion was made by Ken Smith, seconded by Britni Toth to approve the appointment of School Media Affiliates: Western Nebraska Observer, Scottsbluff Star Herald, KNEB Radio, KSID, and KIMB Radio. After discussion and upon roll call vote, the Board voted as follows:

- Travis Cook: Aye
- Jennifer Griebel: Aye
- Lanny Little: Aye
- Tom O'Brien: Aye
- Ken Smith: Aye
- Britni Toth: Aye

Motion was made by Tom O'Brien, seconded by Travis Cook to approve the appointment of the School Financial Affiliates: FirsTier Bank, Kimball State Bank, Points West Community Bank; and approve the Signatures for the Board President, Board Treasurer, Superintendent, and Business Manager. After discussion and upon roll call vote, the Board voted as follows:

- Travis Cook: Aye
- Jennifer Griebel: Aye
- Lanny Little: Aye
- Tom O'Brien: Aye
- Ken Smith: Aye
- Britni Toth: Aye

Motion was made by Britni Toth, seconded by Lanny Little to approve the appointment of the Superintendent as District Representative for Federal Programs (Policy 302.01). After discussion and upon roll call vote, the Board voted as follows:

Travis Cook: Aye  
Jennifer Griebel: Aye  
Lanny Little: Aye  
Tom O'Brien: Aye  
Ken Smith: Aye  
Britni Toth: Aye

Motion was made by Britni Toth, seconded by Ken Smith to approve the Superintendent contract as presented. After discussion and upon roll call vote, the Board voted as follows:

Travis Cook: Aye  
Jennifer Griebel: Aye  
Lanny Little: Aye  
Tom O'Brien: Aye  
Ken Smith: Aye  
Britni Toth: Aye

Motion was made by Lanny Little, seconded by Travis Cook to approve the 2024-2025 and 2025-2026 Negotiated Agreement. After discussion and upon roll call vote, the Board voted as follows:

Ken Smith: Abstain (With Conflict)  
Travis Cook: Aye  
Jennifer Griebel: Aye  
Lanny Little: Aye  
Tom O'Brien: Aye  
Britni Toth: Aye

The Board discussed and reviewed Board Policy 203.09 (Code of Conduct/ Code of Ethics).

The Board reviewed the Yearly Planning Calendar.

The Board discussed policy options for tuition reimbursement for staff members.

The Board discussed how a four-day school week would work for KPS for the 2024-25 school year.

Motion was made by Lanny Little, seconded by Tom O'Brien to adjourn the meeting at 7:53 p.m.. After discussion and upon roll call vote, the Board voted as follows:

Travis Cook: Aye  
Jennifer Griebel: Aye  
Lanny Little: Aye  
Tom O'Brien: Aye  
Ken Smith: Aye  
Britni Toth: Aye

ATTEST:

TRAVIS COOK  
KIMBALL PUBLIC SCHOOLS  
BOARD OF EDUCATION

THOMAS O'BRIEN  
KIMBALL PUBLIC SCHOOLS  
BOARD OF EDUCATION

**Kimball Public Schools  
BOARD REPORT OF EXPENDITURES  
2/12/2024**

62043		\$ 3,931.46
	<b>PREPAID</b>	
		<b>\$3,931.46</b>

**REGULAR MONTHLY EXPENSES**

62045	AG PARTS WORLDWIDE	85.75
62046	ARBOR SCIENTIFIC	301.63
62047	BERGANKDV,LTD	212.80
62049	BEST PLUMBING, HEATING & COOLING LLC	468.70
62050	CAPITAL BUSINESS SYSTEMS, INC.	2,554.23
62052	CENTURY LINK BUSINESS SERVICES	292.64
62053	CHANEY ELECTRONICS, INC.	129.52
62054	CITY OF KIMBALL	12,922.95
62055	COLORADO/WEST EQUIPMENT	213.89
62056	CROSSROADS MUSIC	170.00
62057	CSC MUSIC DEPARTMENT	140.00
62058	CULLIGAN	189.45
62059	GRANITE TELECOMMUNICATIONS	794.77
62060	IDEAL/BLUFFS FACILITY SOLUTIONS	2,615.16
62061	J.W. PEPPER & SON INC.	450.97
62062	JOHNSON CONTROLS	1,911.43
62063	DAS STATE ACCOUNTING - CENTRAL	267.63
62064	ESU #13	44,513.77
62065	FOLLETT SCHOOL SOLUTIONS, INC	1,381.74
62066	FRANK PARTS COMPANY	45.56
62067	FRENCHMAN VALLEY COOP	827.25
62068	GERING VALLEY PLUMBING & HEATING, INC	819.00
62069	K12 SCHOOL SUPPLIES	310.31
62070	KIMBALL ACE HARDWARE	353.03
62071	KIMBALL AUTO PARTS CO	1,443.85
62072	KIMBALL HEALTH SERVICES	10,489.50
62073	KIMBALL PUBLIC SCHOOLS	2,285.00
62074	KIMBALL SERVICE CENTER	20.00
62075	ANITA LEWISON	200.00
62076	WILLIAM LONG	353.25
62077	MENARDS - SCOTTSBLUFF	19.92
62078	MID-WEST 3D SOLUTIONS	780.00
62079	JESSICA MILLER	267.33
62080	MONUMENT CLEANING COMPANY	8,140.00
62081	NASB	627.00

62082	NE COLORADO CELLULAR, INC.	98.90
62083	NEBRASKA ASSOCIATION OF SCHOOL	4,661.00
62084	NEBRASKA SAFETY AND FIRE EQUIPMENT,	203.76
62086	PANHANDLE COOP ASSOCIATION	4,812.76
62087	PERRY, GUTHERY, HAASE & GESSFO	1,023.70
62088	PROPIO LS LLC	206.55
62089	ROCKY MOUNTAIN AIR SOLUTIONS	311.32
62090	SIDNEY GLASS	308.70
62091	STATE CHEMICAL MFG CO	2,054.80
62092	VERIZON WIRELESS	52.93
62093	WESTERN NEBRASKA OBSERVER	206.10
62094	AMBER WILKE	288.00
62095	BLACK HILLS ENERGY	4,214.55
62096	NEBRASKA SAFETY AND FIRE EQUIPMENT,	1,287.00
62097	BEST PLUMBING, HEATING & COOLING LLC	170.00
62098	BEST PLUMBING, HEATING & COOLING LLC	1,293.38

**GENERAL FUND TOTAL** 117,791.48

6244	CASH-WA DISTRIBUTING	10,564.48
6245	HILAND DAIRY FOODS COMPANY, LLC	2,945.44
6246	INFINITE CAMPUS	458.00
6247	PEPSI-COLA OF WESTERN NEBRASKA	1,785.00
6248	US FOODS - GRAND ISLAND	8,448.65

**NUTRITION FUND TOTAL \$** 24,201.57

1261	KIDWELL	<u>\$ 1,260.00</u>
------	---------	--------------------

**DEPRECIATION FUND TOTAL \$** 1,260.00

1559	BOKF, NA	250,958.75
1560	KIMBALL ACE HARDWARE	103.70
1561	KIMBALL PUBLIC SCHOOLS	968.32

**BUILDING FUND** \$252,030.77

**TOTAL MONTHLY BILLS** \$395,283.82

**Detail Check Register**

Checking Account: 01

GENERAL FUND 01-101

Invoice Number	Invoice Date	PO Number	Detail Description	Chart of Account Number	Detail Amount
111-1561875-1775433	12/13/2023	13053	Vaultz Portable File Storage Box with Ha	01 2220 610 003 000	74.20
111-2186592-0539424	12/05/2023	13023	American Flag 4x6 Outdoor Heavy Duty	01 2620 720 001 000	43.60
111-4436968-1489800	12/13/2023	13062	Candy & Chocolate Assorted Variety Pack	01 1100 610 001 040	29.90
111-4436968-1489800	12/13/2023	13062	Welding Skills by B. J. Moniz	01 1100 610 001 040	117.24
111-4436968-1489800	12/13/2023	13062	HOPELF 6" Natural Bamboo Skewers for BBQ	01 1100 610 001 040	5.88
111-4436968-1489800	12/13/2023	13062	240 Sheets Tissue Paper for Gift Bags, 2	01 1100 610 001 040	7.99
111-4436968-1489800	12/13/2023	13062	FloraCraft Floral Desert DryFoM 6 Piece	01 1100 610 001 040	22.22
111-4436968-1489800	12/13/2023	13062	Douglas Zeb Texas Longhorn Bull Plush St	01 1100 610 001 040	47.60
111-4436968-1489800	12/13/2023	13062	Before We Eat	01 1100 610 001 040	9.95
111-4614211-5368264	01/12/2024	13020	104 Pcs Kazoos Bulk Plastic Kazoos for A	01 1100 610 003 032	34.79
111-4614211-5368264	01/12/2024	13020	SHIPPING	01 1100 610 003 032	6.99
111-4820788-6788211	12/05/2023	13023	Free Shipping	01 2610 890 001 000	7.00
111-4820788-6788211	12/05/2023	13023	AGAS Nebraska State Flag 4x6 Ft	01 2620 720 001 000	191.52
111-4971820-4934612	12/13/2023	13053	https://www.amazon.com/gp/product/B09YCB	01 2220 610 003 000	9.99
111-4971820-4934612	12/13/2023	13053	https://www.amazon.com/gp/product/B09YCB	01 2220 610 003 000	9.99
111-4971820-4934612	12/13/2023	13053	ADVANTUS PVC-Free Badge Holders, Vertica	01 2220 610 003 000	14.98
111-4971820-4934612	12/13/2023	13053	SHIPPING	01 2220 610 003 000	5.61
111-6173209-4794600	12/08/2023	13033	Dust mop for Gym floor	01 1100 890 001 000	210.00
111-9008126-2722615	01/12/2024	12988	Blue Starts Furnace Flame Sensor	01 2620 720 003 000	20.97
111-9008126-2722615	01/12/2024	12988	Shipping and Handling	01 2620 890 003 000	6.99
113-2471422-8129864-	12/11/2023	13058	MaxxFlo Rain Gutter Adapter	01 2620 720 003 000	28.86
113-5303257-0549818	12/11/2023	13058	Shipping & Handling	01 2610 890 003 000	6.99
113-5303257-0549818	12/11/2023	13058	Promotion	01 2610 890 003 000	(1.40)
113-5303257-0549818	12/11/2023	13058	Gutter Downspout Braces	01 2620 720 003 000	27.98
113-5829911-2143407	12/20/2023	13060	Dirt Devil Bagless Vacuum	01 2620 890 003 000	89.00
113-8896666-7289835	12/05/2023	13026	Instax Mini Film	01 2410 890 003 000	75.90
113-8896666-7289835	12/05/2023	13026	Amazon Discount	01 2410 890 003 000	(3.92)
114-0229097-7418612	12/13/2023	13065	red kap shop overalls	01 2710 610 000 000	29.99
114-0229097-7418612	12/13/2023	13065	SHIPPING	01 2710 610 000 000	6.99
114-0676705-3852241	12/13/2023	13066	StarTech.com USB C to DVI Adapter - Blac	01 2230 650 000 000	48.70
114-5731626-5849830	12/08/2023	13040	2" Width, 100' Length Floor Marking Tape	01 2620 610 000 000	50.66
114-5731626-5849830	12/08/2023	13040	2" Width, 100' Length Floor Marking Tape	01 2710 610 000 000	50.66
114-5731626-5849830	12/08/2023	13040	shipping	01 2710 610 000 000	11.31
2023 HOLIDAY PARTY	01/12/2024	13089	End of Semester Staff Meal	01 2310 890 000 000	1,428.86
2023-12-BOARD MEETIN	01/12/2024	13061	BOARD MEAL	01 2320 890 000 000	33.16
2023-24 SCHOLASTIC	01/12/2024	12916	Scholastic Teachables	01 1200 640 001 902	29.99
2023-24 SUBSCRIPTION	01/12/2024	13025	9-months Premium Subscription Mosyle Man	01 2230 735 000 000	4.12
2023-STATE PRINCIPAL	01/12/2024	13045	Breakfast	01 2410 580 001 905	7.19

Check Total: 3,931.46

**Detail Check Register**

**Checking Account: 01**

**GENERAL FUND 01-101**

2023-STATE PRINCIPAL	01/12/2024	13045	Fuel @ Shell	01 2410 580 001 905	39.79
2023-STATE PRINCIPAL	01/12/2024	13045	Supper	01 2410 580 001 905	32.57
2023-STATE PRINCIPAL	01/12/2024	13045	Parking	01 2410 580 001 905	11.25
2023-STATE PRINCIPAL	01/12/2024	13045	Fuel at Casey's General Store	01 2410 580 001 905	41.99
2024-DOOR DECORATION	01/12/2024		DOOR DECORATION WINNERS	01 2410 890 001 000	70.00
2024-STATE REGISTRAT	01/12/2024	13093	state registration fee	01 2120 610 003 000	175.00
86648540	01/12/2024		NOVEMBER INDEED INVOICE	01 2510 890 000 000	223.00
DONUTS 2023-12	01/12/2024	13079	Donuts for 10th Caller	01 2410 610 001 000	37.50
DVD PLAYER HS	01/12/2024	13004	LG 1080P DVD 071919261766	01 2230 650 000 000	37.00
DVD PLAYER HS	01/12/2024	13004	6" HDMI Cable	01 2230 650 000 000	6.98
DVD PLAYER HS	01/12/2024	13004	Tax	01 2230 650 000 000	3.08
SCOREBOARD REPAIR	01/12/2024	13059	Shipping FedEx 2-Day Delivery	01 2610 890 001 000	55.00
SCOREBOARD REPAIR	01/12/2024	13059	Indoor Yellow 9" Digit Panel	01 2620 720 001 000	100.00
SIGNS FOR ML	01/12/2024	13157	Store of Signs - Respect Sign	01 2410 890 003 000	61.00
SIGNS FOR ML	01/12/2024	13157	Store of Signs - Responsibility Sign	01 2410 890 003 000	57.95
SIGNS FOR ML	01/12/2024	13157	Store of Signs - Effort Sign	01 2410 890 003 000	57.95
SIGNS FOR ML	01/12/2024	13157	Store of Signs - Safety Sign	01 2410 890 003 000	57.95
SIGNS FOR ML	01/12/2024	13157	Store of Signs - Longhorn Pride	01 2410 890 003 000	61.00

\*Denotes Expensed Invoice Item

Checking Account ID: 01

Total without Voids: 3,931.46

**Detail Check Register**

<b>Checking Account: 01</b>		<b>GENERAL FUND 01-101</b>				
Check Number: 112	Check Type: Check	Check Date: 02/07/2024	Vendor: BERGANKDVL	BERGANKDV,LTD	Check Total: 11.20	
<u>Invoice Number</u>	<u>Invoice Date</u>	<u>PO Number</u>	<u>Detail Description</u>	<u>Chart of Account Number</u>	<u>Detail Amount</u>	
JAN INVOICE	02/07/2024		BERGAN INVOICE	01 2510 610 000 000	11.20	
Check Number: 62048	Check Type: Check	Check Date: 02/12/2024	Vendor: BESTHEATIN	BEST HEATING AND COOLING LLC	Check Total: 170.00	
<u>Invoice Number</u>	<u>Invoice Date</u>	<u>PO Number</u>	<u>Detail Description</u>	<u>Chart of Account Number</u>	<u>Detail Amount</u>	
38596	01/08/2024	13148	Trip Charge	01 2610 334 001 000	85.00	
38596	01/08/2024	13148	Service Fee	01 2620 890 001 000	85.00	
V*38596	02/12/2024	13148	Trip Charge	01 2610 334 001 000	(85.00)	
V*38596	02/12/2024	13148	Service Fee	01 2620 890 001 000	(85.00)	
Check Number: 62049	Check Type: Check	Check Date: 02/12/2024	Vendor: BESTPLUMBI	BEST PLUMBING, HEATING & COOLING LLC	Check Total: 468.70	
<u>Invoice Number</u>	<u>Invoice Date</u>	<u>PO Number</u>	<u>Detail Description</u>	<u>Chart of Account Number</u>	<u>Detail Amount</u>	
38854	01/26/2024	13190	Trip Charge	01 2610 334 003 000	85.00	
38854	01/26/2024	13190	Service Fee	01 2610 890 003 000	85.00	
38854	01/26/2024	13190	Furnace Pressure Switch	01 2620 720 003 000	298.70	
Check Number: 62050	Check Type: Check	Check Date: 02/12/2024	Vendor: CAPITALBUS	CAPITAL BUSINESS SYSTEMS, INC.	Check Total: 2,554.23	
<u>Invoice Number</u>	<u>Invoice Date</u>	<u>PO Number</u>	<u>Detail Description</u>	<u>Chart of Account Number</u>	<u>Detail Amount</u>	
1355688	01/24/2024		CONTRACT INVOICE	01 2530 443 000 000	57.70	
1356432	01/15/2024		CONTRACT INVOICE	01 2530 443 000 000	50.00	
1356926	01/24/2024	12586	Material,papaper for new printer	01 2610 334 000 000	300.00	
135696-	01/24/2024	12708	Added material for printer	01 2610 334 000 000	258.75	
35767675-0001	01/22/2024		COPIER LEASE	01 1100 610 000 000	1,887.78	
Check Number: 62051	Check Type: Check	Check Date: 02/12/2024	Vendor: CAPITALBUS	CAPITAL BUSINESS SYSTEMS, INC.	Check Total: 114.36	
<u>Invoice Number</u>	<u>Invoice Date</u>	<u>PO Number</u>	<u>Detail Description</u>	<u>Chart of Account Number</u>	<u>Detail Amount</u>	
CONTRACT I-0009	02/11/2024		CONTRACT INVOICE	01 1100 610 000 000	114.36	
V*CONTRACT I-0009	02/12/2024		CONTRACT INVOICE	01 1100 610 000 000	(114.36)	
Check Number: 62052	Check Type: Check	Check Date: 02/12/2024	Vendor: CENTURYLI2	CENTURY LINK BUSINESS SERVICES	Check Total: 292.64	
<u>Invoice Number</u>	<u>Invoice Date</u>	<u>PO Number</u>	<u>Detail Description</u>	<u>Chart of Account Number</u>	<u>Detail Amount</u>	
672723304-0001	02/20/2024		OUTBOUND VOIP SERVICE	01 2510 530 000 000	292.64	
Check Number: 62053	Check Type: Check	Check Date: 02/12/2024	Vendor: CHANEYELEC	CHANEY ELECTRONICS, INC.	Check Total: 129.52	
<u>Invoice Number</u>	<u>Invoice Date</u>	<u>PO Number</u>	<u>Detail Description</u>	<u>Chart of Account Number</u>	<u>Detail Amount</u>	
91873A	01/09/2024	13081	Electronic kits for auto I	01 2610 610 003 000	129.52	
Check Number: 62054	Check Type: Check	Check Date: 02/12/2024	Vendor: CITYOFKIMB	CITY OF KIMBALL	Check Total: 12,922.95	
<u>Invoice Number</u>	<u>Invoice Date</u>	<u>PO Number</u>	<u>Detail Description</u>	<u>Chart of Account Number</u>	<u>Detail Amount</u>	
JAN 2024-0001	02/25/2024		MAIN BLD WATER	01 2610 410 001 000	73.65	
JAN 2024-0001	02/25/2024		MAIN BLD SEWER	01 2610 410 001 000	200.16	
JAN 2024-0001	02/25/2024		MAIN BLD COLLECTION/LANDFILL	01 2610 410 001 000	515.70	
JAN 2024-0001	02/25/2024		MECHANIC SHOP WATER	01 2610 410 001 000	49.74	

Detail Check Register

Checking Account: 01		GENERAL FUND 01-101			
JAN 2024-0001	02/25/2024		MECHANIC SHOP SEWER	01 2610 410 001 000	244.57
JAN 2024-0001	02/25/2024		AG SHOP SEWER	01 2610 410 001 000	27.00
JAN 2024-0001	02/25/2024		STADIUM WATER	01 2610 410 001 000	33.80
JAN 2024-0001	02/25/2024		STADIUM SEWER	01 2610 410 001 000	27.00
JAN 2024-0001	02/25/2024		AG SHOP COLLECTION-LANDFILL	01 2610 410 001 000	57.30
JAN 2024-0001	02/25/2024		ML E WARD E-W WATER	01 2610 410 003 000	33.80
JAN 2024-0001	02/25/2024		ML E WARD E-W COLLECTION AND LANDFILL	01 2610 410 003 000	343.80
JAN 2024-0001	02/25/2024		ML E WARD E-W SEWER	01 2610 410 003 000	64.42
JAN 2024-0001	02/25/2024		#3 EAST SEWER	01 2610 410 003 000	49.45
JAN 2024-0001	02/25/2024		ML MODULAR WATER	01 2610 410 003 000	45.76
JAN 2024-0001	02/25/2024		ML MODULAR SEWER	01 2610 410 003 000	34.48
JAN 2024-0001	02/25/2024		SOUTH GYM ELECTRIC	01 2610 621 001 000	1,016.08
JAN 2024-0001	02/25/2024		STADIUM ELECTRIC	01 2610 621 001 000	186.40
JAN 2024-0001	02/25/2024		AG SHOP ELECTRIC	01 2610 621 001 000	691.62
JAN 2024-0001	02/25/2024		MAIN BLD ELECTRIC	01 2610 621 001 000	6,976.43
JAN 2024-0001	02/25/2024		#3 EAST ELECTRIC	01 2610 621 003 000	47.75
JAN 2024-0001	02/25/2024		ML E WARD 3-W ELECTRIC	01 2610 621 003 000	1,292.31
JAN 2024-0001	02/25/2024		ML MODULAR ELECTRIC	01 2610 621 003 000	911.73
Check Number: 62055	Check Type: Check	Check Date: 02/12/2024	Vendor: COLORADOWE	COLORADO/WEST EQUIPMENT	Check Total: 213.89
<u>Invoice Number</u>	<u>Invoice Date</u>	<u>PO Number</u>	<u>Detail Description</u>	<u>Chart of Account Number</u>	<u>Detail Amount</u>
0172340-IN	01/23/2024	13188	Air Filter/Cleaner Element	01 2710 610 000 000	213.89
Check Number: 62056	Check Type: Check	Check Date: 02/12/2024	Vendor: CROSSROADS	CROSSROADS MUSIC	Check Total: 170.00
<u>Invoice Number</u>	<u>Invoice Date</u>	<u>PO Number</u>	<u>Detail Description</u>	<u>Chart of Account Number</u>	<u>Detail Amount</u>
77810	02/01/2024	13184	New pads and key reset for clarinet	01 1100 340 001 030	170.00
Check Number: 62057	Check Type: Check	Check Date: 02/12/2024	Vendor: CSCMUSICDE	CSC MUSIC DEPARTMENT	Check Total: 140.00
<u>Invoice Number</u>	<u>Invoice Date</u>	<u>PO Number</u>	<u>Detail Description</u>	<u>Chart of Account Number</u>	<u>Detail Amount</u>
CSC 2023-0001	02/06/2024	12913	Audition fee for CSC High Plains Honor B	01 1100 580 001 030	120.00
CSC 2023-0001	02/06/2024	12913	AUDITION FEE HONOR CHOIR	01 1100 580 001 032	20.00
Check Number: 62058	Check Type: Check	Check Date: 02/12/2024	Vendor: CULLIGAN	CULLIGAN	Check Total: 189.45
<u>Invoice Number</u>	<u>Invoice Date</u>	<u>PO Number</u>	<u>Detail Description</u>	<u>Chart of Account Number</u>	<u>Detail Amount</u>
JAN 2024-0001	02/01/2024		SOFTENER RENTAL	01 2610 610 001 000	69.95
JAN 2024-0001	02/01/2024		SALT DELIVERY-56570	01 2610 610 001 000	35.85
JAN 2024-0001	02/01/2024		SALT DELIVERY-56571	01 2610 610 003 000	83.65
Check Number: 62059	Check Type: Check	Check Date: 02/12/2024	Vendor: GRANITETEL	GRANITE TELECOMMUNICATIONS	Check Total: 794.77
<u>Invoice Number</u>	<u>Invoice Date</u>	<u>PO Number</u>	<u>Detail Description</u>	<u>Chart of Account Number</u>	<u>Detail Amount</u>
2024-01-31-0001	02/01/2024		TELEPHONE SERVICE	01 2510 530 000 000	794.77
Check Number: 62060	Check Type: Check	Check Date: 02/12/2024	Vendor: BLUFFSFACI	IDEAL/BLUFFS FACILITY SOLUTIONS	Check Total: 2,615.16
<u>Invoice Number</u>	<u>Invoice Date</u>	<u>PO Number</u>	<u>Detail Description</u>	<u>Chart of Account Number</u>	<u>Detail Amount</u>

Detail Check Register

Checking Account: 01		GENERAL FUND 01-101				
475685-0003	02/24/2024		PAPER TOWELS AND SANITARY NAPKINS	01 2610 110 001 000	152.79	
476516-0001	01/05/2024	13072	Towel Roll Tork 600 8 Cases	01 2610 610 001 000	71.44	
476516-0001	01/05/2024	13072	Liner 40x46 Black 45gal 100 count	01 2610 610 001 000	120.99	
476516-0001	01/05/2024	13072	Freigh	01 2610 890 001 000	3.00	
476648	01/16/2024	13151	Kutol-Soap-EZ Foam Hand 6/Case	01 2610 610 003 000	204.96	
476648	01/16/2024	13151	T.T. -865 Sheets-Tork-36/CS	01 2610 610 003 000	137.22	
476648	01/16/2024	13151	Freight	01 2610 610 003 000	3.00	
476739	01/19/2024	13102	Laundry Soap-40# Plastic Pail	01 2610 610 001 000	229.45	
477221	01/30/2024	13103	Sanitary Napkin Receptacle-Wall-Plastic	01 2610 610 001 000	156.70	
477221	01/30/2024	13103	Freight	01 2610 610 001 000	3.00	
477399	01/05/2024	13162	Freight	01 2610 890 003 000	3.00	
477399	01/05/2024	13162	Bearing	01 2620 720 003 000	49.94	
477399	01/05/2024	13162	Hourly Rate	01 2620 890 003 000	50.00	
477639	01/19/2024	13152	Liner-38x58-Black-60 Gal-2Mil-10/10's	01 2610 610 001 000	67.49	
477639	01/19/2024	13152	Freight	01 2610 610 001 000	3.00	
477639	01/19/2024	13152	Towel-Roll-Tork-600'-8CS	01 2610 610 001 000	285.76	
477639	01/19/2024	13152	Liner-40x46-Black-45 Gal-2 Mil-100CT	01 2610 610 001 000	80.66	
477639	01/19/2024	13152	Liner-PL-24x32-Wht-45ML-500CT Steel-Flex	01 2610 610 001 000	87.54	
477827	01/30/2023	13161	Freight	01 2610 890 003 000	3.00	
477827	01/30/2023	13161	RTU Consume QT 12/Case	01 2620 720 003 000	83.30	
477827	01/30/2023	13161	ECO Air-Herbal Mint-6/CS	01 2620 720 003 000	27.60	
477827	01/30/2023	13161	ECO Air-Mango-6/CS	01 2620 720 003 000	27.60	
477827	01/30/2023	13161	Towel-roll-premium 12/CS TAD 800' roll	01 2620 720 003 000	319.80	
477827	01/30/2023	13161	Liner-PL-24x32-WHT-.45ML-500CT Steel-Fle	01 2620 720 003 000	87.54	
477827	01/30/2023	13161	Liner-40x46-Black-45GAL-2Mil-100CT	01 2620 720 003 000	80.66	
477827	01/30/2023	13161	Liner-46x50-Black-60 GAL-1.5ML 100CT	01 2620 720 003 000	91.26	
477827	01/30/2023	13161	Tissue-Facial-Cube-Livi 36/CS Premium2 P	01 2620 720 003 000	39.23	
477827	01/30/2023	13161	Bleach-PS-Ultra-128 Oz	01 2620 720 003 000	6.44	
477898	01/19/2024	13165	TISSUE-FACIAL-FLAT-LIVI 30/CS PREMIUM 10	01 2620 720 001 000	70.26	
477898	01/19/2024	13165	Freight	01 2620 890 003 000	3.00	
478239	01/26/2024	13211	Gloves-Nitrile Powder Large-CS	01 2610 610 003 000	62.53	
478239	01/26/2024	13211	Freight	01 2610 610 003 000	3.00	
Check Number: 62061	Check Type: Check	Check Date: 02/12/2024	Vendor: JWPEPPERSO	J.W. PEPPER & SON INC.	Check Total: 450.97	
<u>Invoice Number</u>	<u>Invoice Date</u>	<u>PO Number</u>	<u>Detail Description</u>	<u>Chart of Account Number</u>	<u>Detail Amount</u>	
366074721	01/23/2024	13174	Concert music for contest	01 1100 610 001 030	85.00	
366074721	01/23/2024	13174	Solo music for contest	01 1100 610 001 030	15.98	
366074721	01/23/2024	13174	shipping	01 1100 610 001 030	22.99	
366077896	01/23/2024	13174	Concert music for contest	01 1100 610 001 030	170.00	
366077896	01/23/2024	13174	Jazz Band Music	01 1100 610 001 030	92.00	
366077896	01/23/2024	13174	pep band music	01 1100 610 001 030	65.00	

Detail Check Register

Checking Account: 01

GENERAL FUND 01-101

Check Number: 62062      Check Type: Check      Check Date: 02/12/2024      Vendor: JOHNSONCON      JOHNSON CONTROLS      Check Total: 1,911.43

<u>Invoice Number</u>	<u>Invoice Date</u>	<u>PO Number</u>	<u>Detail Description</u>	<u>Chart of Account Number</u>	<u>Detail Amount</u>
1-131924993753	01/23/2024	13193	Mileage	01 2620 334 003 000	323.84
1-131924993753	01/23/2024	13193	Materials- Filter	01 2620 720 003 000	47.59
1-131924993753	01/23/2024	13193	Fuel-Surcharge Adjustment	01 2620 890 003 000	70.00
1-131924993753	01/23/2024	13193	Disposal, Environmental & Usage Charge R	01 2620 890 003 000	110.00
1-131924993753	01/23/2024	13193	Labor - Regular Mechanic Heavy	01 2620 890 003 000	720.00
1-131924993753	01/23/2024	13193	Labor-Regular Mechanic Heavy	01 2620 890 003 000	640.00

Check Number: 62063      Check Type: Check      Check Date: 02/12/2024      Vendor: DASSTATEAC      DAS STATE ACCOUNTING - CENTRAL FINANCE      Check Total: 267.63

<u>Invoice Number</u>	<u>Invoice Date</u>	<u>PO Number</u>	<u>Detail Description</u>	<u>Chart of Account Number</u>	<u>Detail Amount</u>
1393868-0002	02/08/2024		JAN 2023	01 2510 382 000 000	267.63

Check Number: 62064      Check Type: Check      Check Date: 02/12/2024      Vendor: ESU13      ESU #13      Check Total: 44,513.77

<u>Invoice Number</u>	<u>Invoice Date</u>	<u>PO Number</u>	<u>Detail Description</u>	<u>Chart of Account Number</u>	<u>Detail Amount</u>
ASD TRAINING 2024	01/16/2024		ASD TRAINING-CHESLEY	01 1200 330 003 000	10.00
DECEMBER B-0001	12/29/2023		VALLEY ALT LEARNING TRANSITION SCHOOL	01 1100 591 003 000	2,000.00
DECEMBER B-0001	12/29/2023		SPECIAL EDUCATION INSERVICE	01 1200 330 000 000	81.90
DECEMBER B-0001	12/29/2023		PANHANDLE BEGINNINGS DAY SCHOOL	01 1200 561 000 003	1,026.60
DECEMBER B-0001	12/29/2023		MERIDIAN TUITION - ESU	01 1200 561 001 003	4,398.00
DECEMBER B-0001	12/29/2023		LIFELINKS TUITION - ESU	01 1200 561 001 007	2,199.00
DECEMBER B-0001	12/29/2023		SUPERVISION OF PROGRAMS - ESU	01 1200 591 000 005	682.13
DECEMBER B-0001	12/29/2023		ESU - MIPS CLERICAL	01 1200 591 001 902	200.00
DECEMBER B-0001	12/29/2023		SPED INSTRUCTION AGES 3-5	01 1291 591 003 000	826.58
DECEMBER B-0001	12/29/2023		SPED SUPERVISION AGES 3-5	01 1291 591 003 005	66.13
DECEMBER B-0001	12/29/2023		SPED INSTRUCTION AGES 0-2	01 1292 591 003 000	1,363.08
DECEMBER B-0001	12/29/2023		SPED SUPERVISION AGES 0-2	01 1292 591 003 005	109.05
DECEMBER B-0001	12/29/2023		PSYCH ASSESSMENT HS - ESU	01 2141 591 001 001	4,074.49
DECEMBER B-0001	12/29/2023		PSYCH ASSESSMENT ML - ESU	01 2141 591 003 001	4,370.21
DECEMBER B-0001	12/29/2023		SPEECH HS - ESU	01 2151 591 001 003	391.23
DECEMBER B-0001	12/29/2023		SUPERVISION - SPEECH HS - ESU	01 2151 591 001 005	31.30
DECEMBER B-0001	12/29/2023		P/T SCHOOL AGE HS	01 2171 591 001 000	105.30
DECEMBER B-0001	12/29/2023		P/T SCHOOL AGE HS SUPERVISION	01 2171 591 001 005	8.42
DECEMBER B-0001	12/29/2023		NDE ASSESSMENT WORKSHOP	01 2213 330 000 000	25.00
DECEMBER B-0001	12/29/2023		PRLR-NEW TEACHER ACADEMY	01 2213 330 000 000	50.00
DECEMBER B-0001	12/29/2023		REIMBURSIBLE DISTANCE LEARNING	01 2224 382 000 000	826.00
DECEMBER B-0001	12/29/2023		INTERNET CONSORTIUM	01 2224 382 000 000	450.00
DECEMBER B-0001	12/29/2023		NEBRASKA EDUCATIONAL VIRTUAL ACADEMY	01 2224 382 000 000	708.33
JAN BILL 2-0001	01/31/2024		SPECIAL EDUCATION INSERVICE	01 1200 330 000 000	81.90
JAN BILL 2-0001	01/31/2024		PANHANDLE BEGINNINGS DAY SCHOOL	01 1200 561 000 003	1,026.60
JAN BILL 2-0001	01/31/2024		MERIDIAN TUITION - ESU	01 1200 561 001 003	4,398.00

Detail Check Register

Checking Account: 01

GENERAL FUND 01-101

JAN BILL 2-0001	01/31/2024	LIFELINKS TUITION - ESU	01 1200 561 001 007	2,199.00
JAN BILL 2-0001	01/31/2024	SUPERVISION OF PROGRAMS - ESU	01 1200 591 000 005	682.13
JAN BILL 2-0001	01/31/2024	ESU - MIPS CLERICAL	01 1200 591 001 902	120.00
JAN BILL 2-0001	01/31/2024	SPED INSTRUCTION AGES 3-5	01 1291 591 003 000	629.00
JAN BILL 2-0001	01/31/2024	SPED SUPERVISION AGES 3-5	01 1291 591 003 005	50.32
JAN BILL 2-0001	01/31/2024	SPED INSTRUCTION AGES 0-2	01 1292 591 003 000	586.08
JAN BILL 2-0001	01/31/2024	SPED SUPERVISION AGES 0-2	01 1292 591 003 005	46.89
JAN BILL 2-0001	01/31/2024	PSYCH ASSESSMENT HS - ESU	01 2141 591 001 001	5,333.49
JAN BILL 2-0001	01/31/2024	PSYCH ASSESSMENT ML - ESU	01 2141 591 003 001	3,111.21
JAN BILL 2-0001	01/31/2024	SPEECH HS - ESU	01 2151 591 001 003	114.21
JAN BILL 2-0001	01/31/2024	SUPERVISION - SPEECH HS - ESU	01 2151 591 001 005	9.14
JAN BILL 2-0001	01/31/2024	P/T SCHOOL AGE HS	01 2171 591 001 000	105.30
JAN BILL 2-0001	01/31/2024	P/T SCHOOL AGE HS SUPERVISION	01 2171 591 001 005	8.42
JAN BILL 2-0001	01/31/2024	NDE ASSESSMENT WORKSHOP	01 2213 330 000 000	25.00
JAN BILL 2-0001	01/31/2024	INTERNET CONSORTIUM	01 2224 382 000 000	450.00
JAN BILL 2-0001	01/31/2024	NEBRASKA EDUCATIONAL VIRTUAL ACADEMY	01 2224 382 000 000	708.33
JAN BILL 2-0001	01/31/2024	REIMBURSIBLE DISTANCE LEARNING	01 2224 382 000 000	826.00

Check Number: 62065

Check Type: Check

Check Date: 02/12/2024 Vendor: FOLLETTSCH

FOLLETT SCHOOL SOLUTIONS, INC

Check Total:

1,381.74

<u>Invoice Number</u>	<u>Invoice Date</u>	<u>PO Number</u>	<u>Detail Description</u>	<u>Chart of Account Number</u>	<u>Detail Amount</u>
2023-24 RE-0001	02/06/2024	13208	Follet Hosted Service Renewal	01 2220 650 001 000	697.89
2023-24 RE-0001	02/06/2024	13208	Titlepeek online service renewal	01 2220 650 001 000	150.00
326908--0001	02/06/2024	13187	The Naturals	01 2220 640 001 000	17.82
326908-0001	02/06/2024	13187	The Body in the Woods	01 2220 640 001 000	20.80
326908-0001	02/06/2024	13187	The Captive Kingdom	01 2220 640 001 000	18.06
326908-0001	02/06/2024	13187	City of Heavenly Fire	01 2220 640 001 000	23.47
326908-0001	02/06/2024	13187	Danger and other Unknown Risks	01 2220 640 001 000	23.47
326908-0001	02/06/2024	13187	In the Shadow of the Fallen Towers	01 2220 640 001 000	18.96
326908-0001	02/06/2024	13187	Incredible Doom (vol 1)	01 2220 640 001 000	23.47
326908-0001	02/06/2024	13187	The Wide Window	01 2220 640 001 000	13.22
326908-0001	02/06/2024	13187	Revealed	01 2220 640 001 000	20.77
326908-0001	02/06/2024	13187	Run	01 2220 640 001 000	23.47
326908-0001	02/06/2024	13187	Second Chance	01 2220 640 001 000	15.22
326908-0001	02/06/2024	13187	Shadow and Bone	01 2220 640 001 000	18.96
326908-0001	02/06/2024	13187	The Shattered Castle	01 2220 640 001 000	18.06
326908-0001	02/06/2024	13187	Smaller Sister	01 2220 640 001 000	21.67
326908-0001	02/06/2024	13187	Incredible Doom (vol 2)	01 2220 640 001 000	24.37
326908-0001	02/06/2024	13187	My Own World	01 2220 640 001 000	21.73
326908-0001	02/06/2024	13187	Nemesis	01 2220 640 001 000	12.34
326908-0001	02/06/2024	13187	Nyxia	01 2220 640 001 000	20.53
326908-0001	02/06/2024	13187	Nyxia Unleashed	01 2220 640 001 000	18.85
326908-0001	02/06/2024	13187	Nyxia Uprising	01 2220 640 001 000	21.36

**Detail Check Register**

<b>Checking Account: 01</b>		<b>GENERAL FUND 01-101</b>				
330317-0001	02/06/2024	13196	Escape from Mr. Lemoncell's Library	01 2220 640 003 000	18.06	
330317-0001	02/06/2024	13196	Heroes by a Hair	01 2220 640 003 000	16.23	
330317-0001	02/06/2024	13196	Just Roll with It	01 2220 640 003 000	19.86	
330317-0001	02/06/2024	13196	Lab Magic!	01 2220 640 003 000	17.16	
330317-0001	02/06/2024	13196	Winter Wonderland	01 2220 640 003 000	16.26	
330317-0001	02/06/2024	13196	Zip, Zoom!	01 2220 640 003 000	16.26	
330317-0001	02/06/2024	13196	Beach Day!	01 2220 640 003 000	16.26	
330317-0001	02/06/2024	13196	Camp OU!	01 2220 640 003 000	17.16	
Check Number: 62066	Check Type: Check	Check Date: 02/12/2024	Vendor: FRANKPARTS	FRANK PARTS COMPANY	Check Total: 45.56	
<u>Invoice Number</u>	<u>Invoice Date</u>	<u>PO Number</u>	<u>Detail Description</u>	<u>Chart of Account Number</u>	<u>Detail Amount</u>	
515827	02/05/2024	12710	General supply and repiar	01 1100 610 001 044	45.56	
Check Number: 62067	Check Type: Check	Check Date: 02/12/2024	Vendor: FRENCHMANV	FRENCHMAN VALLEY COOP	Check Total: 827.25	
<u>Invoice Number</u>	<u>Invoice Date</u>	<u>PO Number</u>	<u>Detail Description</u>	<u>Chart of Account Number</u>	<u>Detail Amount</u>	
2024/01/31-0001	01/31/2024		CARDTROL FUEL PURCHASES	01 2710 626 000 000	827.25	
Check Number: 62068	Check Type: Check	Check Date: 02/12/2024	Vendor: GERINGVALL	GERING VALLEY PLUMBING & HEATING, INC	Check Total: 819.00	
<u>Invoice Number</u>	<u>Invoice Date</u>	<u>PO Number</u>	<u>Detail Description</u>	<u>Chart of Account Number</u>	<u>Detail Amount</u>	
59935119-0001	01/31/2024		DRAIN CLEAN OUT	01 2620 340 001 000	819.00	
Check Number: 62069	Check Type: Check	Check Date: 02/12/2024	Vendor: K12SCHOOLS	K12 SCHOOL SUPPLIES	Check Total: 310.31	
<u>Invoice Number</u>	<u>Invoice Date</u>	<u>PO Number</u>	<u>Detail Description</u>	<u>Chart of Account Number</u>	<u>Detail Amount</u>	
88977	02/06/2024	13229	Globes	01 1100 610 001 038	310.31	
Check Number: 62095	Check Type: Check	Check Date: 02/12/2024	Vendor: BLACKHILLS	BLACK HILLS ENERGY	Check Total: 4,214.55	
<u>Invoice Number</u>	<u>Invoice Date</u>	<u>PO Number</u>	<u>Detail Description</u>	<u>Chart of Account Number</u>	<u>Detail Amount</u>	
2024-JAN	02/07/2024		HIGH SCHOOL	01 2610 621 001 000	2,921.93	
2024-JAN	02/07/2024		MARY LYNCH	01 2610 621 003 000	1,292.62	
Check Number: 62096	Check Type: Check	Check Date: 02/12/2024	Vendor: NESAFETYAN	NEBRASKA SAFETY AND FIRE EQUIPMENT, INC	Check Total: 1,287.00	
<u>Invoice Number</u>	<u>Invoice Date</u>	<u>PO Number</u>	<u>Detail Description</u>	<u>Chart of Account Number</u>	<u>Detail Amount</u>	
63848	02/07/2024	13098	S/A Fire Alarm System Inspection	01 2620 340 001 000	450.00	
63848	02/07/2024	13098	S/A Range Hood Fire Extinguisher Inspect	01 2620 340 001 000	135.00	
63848	02/07/2024	13098	XV Test Cartridge	01 2620 340 001 000	40.00	
63848	02/07/2024	13098	ML-360 Fusible Links	01 2620 340 001 000	26.00	
63848	02/07/2024	13098	12V 7AH FACP BATTERY	01 2620 340 001 000	130.00	
63849	02/07/2024	13097	S/A Fire Alarm System Inspection	01 2620 340 000 000	180.00	
63849	02/07/2024	13097	S/A Range Hood Fire Extinguisher Inspect	01 2620 340 003 000	135.00	
63849	02/07/2024	13097	XV Test Cartridge	01 2620 340 003 000	40.00	
63849	02/07/2024	13097	ML-360 Fusible Link	01 2620 340 003 000	26.00	
63849	02/07/2024	13097	S/A Fire Alarm System Inspection (Modula	01 2620 340 003 000	125.00	

**Detail Check Register**

<b>Checking Account: 01</b>		<b>GENERAL FUND 01-101</b>					
Check Number: 62097	Check Type: Check	Check Date: 02/12/2024	Vendor: BESTPLUMBI	BEST PLUMBING, HEATING & COOLING LLC	Check Total:	170.00	
<u>Invoice Number</u>	<u>Invoice Date</u>	<u>PO Number</u>	<u>Detail Description</u>	<u>Chart of Account Number</u>	<u>Detail Amount</u>		
38596	01/08/2024	13148	Trip Charge	01 2610 334 001 000	85.00		
38596	01/08/2024	13148	Service Fee	01 2620 890 001 000	85.00		
Check Number: 62098	Check Type: Check	Check Date: 02/12/2024	Vendor: BESTPLUMBI	BEST PLUMBING, HEATING & COOLING LLC	Check Total:	1,293.38	
<u>Invoice Number</u>	<u>Invoice Date</u>	<u>PO Number</u>	<u>Detail Description</u>	<u>Chart of Account Number</u>	<u>Detail Amount</u>		
38842	02/08/2024	13262	Trip Charge	01 2610 334 001 000	170.00		
38842	02/08/2024	13262	New Fittings for furnace	01 2620 720 001 000	25.00		
38842	02/08/2024	13262	Furnace Ignitor	01 2620 720 001 000	193.22		
38842	02/08/2024	13262	Furnace Gas Valve	01 2620 720 001 000	167.48		
38842	02/08/2024	13262	Labor	01 2620 720 001 000	165.00		
38842	02/08/2024	13262	Labor to install components upon return	01 2620 720 001 000	330.00		
38842	02/08/2024	13262	Emergency After-hours labor	01 2620 720 001 000	165.00		
38842	02/08/2024	13262	Freight	01 2620 890 001 000	77.68		
Check Number: 962045	Check Type: Check	Check Date: 02/12/2024	Vendor: AGPARTSED	AG PARTS WORLDWIDE	Check Total:	85.75	
<u>Invoice Number</u>	<u>Invoice Date</u>	<u>PO Number</u>	<u>Detail Description</u>	<u>Chart of Account Number</u>	<u>Detail Amount</u>		
076137	12/04/2023	12996	HP 11 G6-EE (TOUCH & NON) / 11A G6-EE (T	01 2230 650 000 000	9.95		
076137	12/04/2023	12996	HP 11 G6-EE (TOUCH & NON) / 11A G6-EE (T	01 2230 650 000 000	4.95		
080303	01/19/2024	13168	HP 11 G6-EE 11.6" LCD	01 2230 650 000 000	21.95		
080303	01/19/2024	13168	HP 11 G6-EE / 11A G6-EE LCD VIDEO CABLE	01 2230 650 000 000	8.95		
082043	02/06/2024	13230	HP 11 G6-EE MOTHERBOARD 4GB	01 2230 650 000 000	39.95		
Check Number: 962046	Check Type: Check	Check Date: 02/12/2024	Vendor: ARBORSCIEN	ARBOR SCIENTIFIC	Check Total:	301.63	
<u>Invoice Number</u>	<u>Invoice Date</u>	<u>PO Number</u>	<u>Detail Description</u>	<u>Chart of Account Number</u>	<u>Detail Amount</u>		
476511-0001	01/29/2024	13175	Power Supply-Spectrum analysis	01 1100 610 001 036	199.00		
476511-0001	01/29/2024	13175	Spectrum tube-argon	01 1100 610 001 036	25.00		
476511-0001	01/29/2024	13175	Spectrum tube-helium	01 1100 610 001 036	25.00		
476511-0001	01/29/2024	13175	Spectrum tube-neon	01 1100 610 001 036	25.00		
476511-0001	01/29/2024	13175	Freight	01 1100 610 001 036	27.63		
Check Number: 962047	Check Type: Check	Check Date: 02/12/2024	Vendor: BERGANKDVL	BERGANKDV,LTD	Check Total:	201.60	
<u>Invoice Number</u>	<u>Invoice Date</u>	<u>PO Number</u>	<u>Detail Description</u>	<u>Chart of Account Number</u>	<u>Detail Amount</u>		
2023-11 IN-0003	02/06/2024		BERGAN PAYROLL PROCESSING	01 2510 610 000 000	201.60		
Check Number: 962070	Check Type: Check	Check Date: 02/12/2024	Vendor: ACEHARDWAR	KIMBALL ACE HARDWARE	Check Total:	353.03	
<u>Invoice Number</u>	<u>Invoice Date</u>	<u>PO Number</u>	<u>Detail Description</u>	<u>Chart of Account Number</u>	<u>Detail Amount</u>		
4425-0001	12/29/2023	13094	Red N' Tacky Lithium Grease 14OZ	01 2710 610 000 000	15.98		
4440-0001	01/02/2024	13095	ReKey LockBox	01 2710 610 000 000	4.94		
4453-0001	01/04/2024	13122	key	01 2710 610 000 000	2.99		
4463-0001	01/04/2024	13123	Lime-Rust-Remover 28oz CLR	01 2620 720 001 000	11.20		

**Detail Check Register**

Checking Account: 01		GENERAL FUND 01-101				
4463-0001	01/04/2024	13123	Loaf Pan 8x3.75" 3 Pack	01 2620 720 001 000	2.07	
4514	01/11/2024	13150	Air Coupler 1/4"x1/4"	01 2710 610 000 000	10.79	
4514	01/11/2024	13150	Push Air Coupler 1/4"	01 2710 610 000 000	8.99	
4514	01/11/2024	13150	Universal Air Coupler Kit 1/4"	01 2710 610 000 000	7.73	
4578	01/18/2024		WOOD SUPPLIES	01 1100 610 001 044	27.76	
4591	01/22/2024		AUTO SUPPLIES	01 1100 610 001 044	25.16	
4619	01/24/2024	13191	Aluminum Downspout Extension	01 2620 720 003 000	14.99	
4619	01/24/2024	13191	Downspout 3" x 4" x10' White	01 2620 720 003 000	20.99	
4619	01/24/2024	13191	Elbow "B" 3" x 4" Aluminum White	01 2620 720 003 000	6.44	
4619	01/24/2024	13191	Aluminum Downspout Band White 13"	01 2620 720 003 000	4.49	
4641	01/26/2024	13215	Masonry Bit Set 14 Piece Bosch	01 2620 610 000 000	19.79	
4648-0001	01/26/2024		WIRE	01 1100 610 001 040	23.99	
4658	01/29/2024		WOOD TOOLS	01 1100 610 001 044	31.99	
4661	01/29/2024	13214	Downspout Adapter 3"x4" White	01 2620 720 003 000	5.99	
4661	01/29/2024	13214	Elbow "A" 3"x4" Aluminum White	01 2620 720 003 000	6.44	
4665	01/29/2024	13213	Downspout Extension Shite 55"L	01 2620 720 003 000	10.49	
4666	01/29/2024	13205	Cable 3/16"7x19 Galvanized 6"	01 2710 890 000 000	8.06	
4689	01/31/2024	13225	Zip ties	01 2710 610 000 000	7.99	
4690	01/31/2024	13226	Pressure Washer Hose 25'	01 2710 610 000 000	53.99	
4701	02/01/2024	13231	Rust-Oleum Striping Paint - Yellow	01 2710 610 000 000	19.78	
Check Number: 962071		Check Type: Check	Check Date: 02/12/2024	Vendor: KIMBALLAUT	KIMBALL AUTO PARTS CO	Check Total: 1,443.85
<u>Invoice Number</u>	<u>Invoice Date</u>	<u>PO Number</u>	<u>Detail Description</u>	<u>Chart of Account Number</u>	<u>Detail Amount</u>	
255608	01/04/2024	12711	General supply and repair	01 1100 610 001 044	9.96	
255780	01/10/2024	13145	Spicer U-Joint B95	01 2710 610 000 000	183.00	
256080	01/18/2024	12711	General supply and repair	01 1100 610 001 044	70.35	
256270	01/24/2024	13194	Filter 95384	01 2710 610 000 000	69.35	
256270	01/24/2024	13194	9 GAL 15w/40 oil	01 2710 626 000 000	168.21	
256496	01/31/2024	13170	Topdon Phoenix lite Scan too	01 1100 733 001 044	915.19	
456445	01/30/2024	13219	V10 Vapor Can Vent Solenoid	01 2710 610 000 000	27.79	
Check Number: 962072		Check Type: Check	Check Date: 02/12/2024	Vendor: KIMBALLHEA	KIMBALL HEALTH SERVICES	Check Total: 10,489.50
<u>Invoice Number</u>	<u>Invoice Date</u>	<u>PO Number</u>	<u>Detail Description</u>	<u>Chart of Account Number</u>	<u>Detail Amount</u>	
2023-FALL -0001	02/06/2024		P/T SCHOOL AGE HS	01 2171 591 001 000	202.50	
2023-FALL -0001	02/06/2024		P/T SCHOOL AGE ML	01 2171 591 003 000	1,458.00	
2023-FALL -0001	02/06/2024		P/T AGES 3-5	01 2172 591 003 000	486.00	
2023-FALL -0001	02/06/2024		P/T AGES 0-2	01 2173 591 003 000	648.00	
OT FALL 20-0001	02/06/2024		OT HS - ESU	01 2161 591 001 000	1,093.50	
OT FALL 20-0001	02/06/2024		OT ML - ESU	01 2161 591 003 000	5,629.50	
OT FALL 20-0001	02/06/2024		OT AGES 3-5	01 2162 591 003 000	688.50	
OT FALL 20-0001	02/06/2024		OT AGES 0-2	01 2163 591 003 000	283.50	
Check Number: 962073		Check Type: Check	Check Date: 02/12/2024	Vendor: KIMBALLPUB	KIMBALL PUBLIC SCHOOLS	Check Total: 2,285.00

**Detail Check Register**

**Checking Account: 01**

**GENERAL FUND 01-101**

<u>Invoice Number</u>	<u>Invoice Date</u>	<u>PO Number</u>	<u>Detail Description</u>	<u>Chart of Account Number</u>	<u>Detail Amount</u>	
100-----0003	02/29/2024		LIBRARY LEGO BOARD	01 2220 610 001 000	85.00	
RUGS	01/19/2024		RUGS REIMB AF HS	01 1100 733 001 000	1,180.00	
RUGS	01/19/2024		RUGS REIMB AF ML	01 1100 733 001 000	960.00	
SPVA JH MUSIC 2024	01/30/2024	13206	Meals for SPVA jr. high music 8 band stu	01 1100 580 001 030	32.00	
SPVA JH MUSIC 2024	01/30/2024	13206	Meals for SPVA Jr High Music 7 choir stu	01 1100 580 001 032	28.00	
Check Number: 962074	Check Type: Check	Check Date: 02/12/2024	Vendor: KIMBALLSER	KIMBALL SERVICE CENTER	Check Total:	20.00
<u>Invoice Number</u>	<u>Invoice Date</u>	<u>PO Number</u>	<u>Detail Description</u>	<u>Chart of Account Number</u>	<u>Detail Amount</u>	
54666-0001	01/03/2024	13104	S20-B Right Rear Tire Repair	01 2710 610 000 000	20.00	
Check Number: 962075	Check Type: Check	Check Date: 02/12/2024	Vendor: LEWISONANI	ANITA LEWISON	Check Total:	200.00
<u>Invoice Number</u>	<u>Invoice Date</u>	<u>PO Number</u>	<u>Detail Description</u>	<u>Chart of Account Number</u>	<u>Detail Amount</u>	
CLARINET PURCHASE	01/24/2024	13183	Used intermediate level clarinet	01 1100 733 001 030	200.00	
Check Number: 962076	Check Type: Check	Check Date: 02/12/2024	Vendor: LONGWILLIA	WILLIAM LONG	Check Total:	353.25
<u>Invoice Number</u>	<u>Invoice Date</u>	<u>PO Number</u>	<u>Detail Description</u>	<u>Chart of Account Number</u>	<u>Detail Amount</u>	
2ND QTR MILEAGE 2024	02/06/2024	13247	William Long	01 2710 332 000 000	353.25	
Check Number: 962077	Check Type: Check	Check Date: 02/12/2024	Vendor: MENARDS	MENARDS - SCOTTSBLUFF	Check Total:	19.92
<u>Invoice Number</u>	<u>Invoice Date</u>	<u>PO Number</u>	<u>Detail Description</u>	<u>Chart of Account Number</u>	<u>Detail Amount</u>	
95929	01/22/2024	13176	Socket Set	01 2710 610 000 000	0.45	
96243	01/23/2024	13192	Screen Molding LWM142 White MDF	01 2620 720 003 000	19.47	
Check Number: 962078	Check Type: Check	Check Date: 02/12/2024	Vendor: MIDWEST3DS	MID-WEST 3D SOLUTIONS	Check Total:	780.00
<u>Invoice Number</u>	<u>Invoice Date</u>	<u>PO Number</u>	<u>Detail Description</u>	<u>Chart of Account Number</u>	<u>Detail Amount</u>	
26271	01/18/2024	12145	3D printer supplies	01 1100 610 001 044	780.00	
Check Number: 962079	Check Type: Check	Check Date: 02/12/2024	Vendor: MILLERJESS	JESSICA MILLER	Check Total:	267.33
<u>Invoice Number</u>	<u>Invoice Date</u>	<u>PO Number</u>	<u>Detail Description</u>	<u>Chart of Account Number</u>	<u>Detail Amount</u>	
2ND QTR MILEAGE 2024	02/06/2024	13248	Mileage Agreement	01 2710 332 000 000	267.33	
Check Number: 962080	Check Type: Check	Check Date: 02/12/2024	Vendor: MONUMENTCL	MONUMENT CLEANING COMPANY	Check Total:	8,140.00
<u>Invoice Number</u>	<u>Invoice Date</u>	<u>PO Number</u>	<u>Detail Description</u>	<u>Chart of Account Number</u>	<u>Detail Amount</u>	
424	02/01/2024	13220	Commuting	01 2610 334 001 000	1,050.00	
424	02/01/2024	13220	Kimball Twice Weekly: Glass, inactive Cl	01 2610 420 001 000	525.00	
424	02/01/2024	13220	Main Gym Add-on	01 2610 420 001 000	750.00	
424	02/01/2024	13220	JV Gym Add-on	01 2610 420 001 000	125.00	
424	02/01/2024	13220	Auditorium Add-on	01 2610 420 001 000	125.00	
424	02/01/2024	13220	Kimball Daily Cleaning	01 2610 420 001 000	5,565.00	
Check Number: 962081	Check Type: Check	Check Date: 02/12/2024	Vendor: NASBALICAP	NASB	Check Total:	627.00
<u>Invoice Number</u>	<u>Invoice Date</u>	<u>PO Number</u>	<u>Detail Description</u>	<u>Chart of Account Number</u>	<u>Detail Amount</u>	

Detail Check Register

Checking Account: 01		GENERAL FUND 01-101			
2022-2023 AUDIT PAYR 01/24/2024		2022-2023 AUDIT PAYROLL ACTUAL			
Check Number:	Check Type:	Check Date:	Vendor:		Check Total:
<u>Invoice Number</u>	<u>Invoice Date</u>	<u>PO Number</u>	<u>Detail Description</u>	<u>Chart of Account Number</u>	<u>Detail Amount</u>
962082	Check	02/12/2024	VIAEROWIRE	NE COLORADO CELLULAR, INC.	98.90
JAN 2024-0001	01/20/2024		HOT SPOTS	01 2510 530 000 000	98.90
962083	Check	02/12/2024	NEASSOSCHO	NEBRASKA ASSOCIATION OF SCHOOL BOARDS	4,661.00
2024-04/2025-03-31	01/30/2024		ANNUAL MEMBERSHIP	01 2310 810 000 000	4,661.00
962084	Check	02/12/2024	NESAFETYAN	NEBRASKA SAFETY AND FIRE EQUIPMENT, INC	203.76
1841	01/15/2024	13134	Red Fire extinguisher Case. 10 lb Capaci	01 2620 720 001 000	178.00
1841	01/15/2024	13134	Freight	01 2620 890 001 000	25.76
962085	Check	02/12/2024	ONESOURCE	ONE SOURCE	54.00
2022145651-0002	02/01/2024		PRE-EMPLOYMENT SCREENINGS	01 2320 890 000 000	54.00
V*2022145651-0002	02/12/2024		PRE-EMPLOYMENT SCREENINGS	01 2320 890 000 000	(54.00)
962086	Check	02/12/2024	PANHANDLEC	PANHANDLE COOP ASSOCIATION	4,812.76
2024-01 CARDTROL	01/31/2024		CARDTROL PURCHASES	01 2710 626 000 000	3,833.43
232770	01/08/2024		DYED DIESEL	01 2710 626 000 000	488.60
232820	01/19/2024		CLEAR #1 DELIVERED BECAUSE PUMPS DOWN	01 2710 626 000 000	391.02
727928	01/18/2024	12628	Groceries for food labs	01 1100 610 001 042	65.24
727962	01/24/2024	13207	ELITE cooking club supplies	01 6968 610 003 000	34.47
962087	Check	02/12/2024	PERRYGUTHE	PERRY, GUTHERY, HAASE & GESSFO	1,023.70
252-0002	02/15/2024		LEGAL SERVICES	01 2330 317 000 000	345.60
253-0001	01/19/2024		LEGAL SERVICES	01 2330 317 000 000	678.10
962088	Check	02/12/2024	PROPIOLSL	PROPIO LS LLC	206.55
0135630923	09/30/2023	13251	Phone Interpretation	01 1100 610 001 024	14.85
0135631123	02/06/2024	13252	Telephone Interpretation	01 1100 610 001 024	176.85
0135631123	02/06/2024	13252	Telephone Interpretation	01 1100 610 001 024	14.85
962089	Check	02/12/2024	ROCKYMOUNT	ROCKY MOUNTAIN AIR SOLUTIONS	311.32
30483537-IN	01/31/2024	13146	CO2 Argon mix	01 1100 610 001 040	311.32
962090	Check	02/12/2024	SIDNEYGLAS	SIDNEY GLASS	308.70

**Detail Check Register**

**Checking Account: 01**

**GENERAL FUND 01-101**

<u>Invoice Number</u>	<u>Invoice Date</u>	<u>PO Number</u>	<u>Detail Description</u>	<u>Chart of Account Number</u>	<u>Detail Amount</u>
OF4R4Z	01/26/2024	13142	36 1/4" x 25" Tempered Glass Panes	01 2620 720 003 000	308.70
Check Number: 962091      Check Type: Check      Check Date: 02/12/2024      Vendor: STATECHEMI      STATE CHEMICAL MFG CO					Check Total: 2,054.80
<u>Invoice Number</u>	<u>Invoice Date</u>	<u>PO Number</u>	<u>Detail Description</u>	<u>Chart of Account Number</u>	<u>Detail Amount</u>
200088457	01/11/2024	13153	Primezyme D5/D19	01 2610 610 001 000	282.70
200088457	01/11/2024	13153	Shark QT 12	01 2610 610 001 000	231.00
200088458	01/16/2024	13154	Primezyme D5/D19	01 2610 610 003 000	282.70
200088458	01/16/2024	13154	Shark QT 12	01 2610 610 003 000	231.00
903207954	01/23/2024	13154	Primezyme D5/D19	01 2610 610 003 000	282.70
903207954	01/23/2024	13154	Shark QT 12	01 2610 610 003 000	231.00
903208166	01/23/2024	13153	Primezyme D5/D19	01 2610 610 001 000	282.70
903208166	01/23/2024	13153	Shark QT 12	01 2610 610 001 000	231.00
Check Number: 962092      Check Type: Check      Check Date: 02/12/2024      Vendor: VERIZON      VERIZON WIRELESS					Check Total: 52.93
<u>Invoice Number</u>	<u>Invoice Date</u>	<u>PO Number</u>	<u>Detail Description</u>	<u>Chart of Account Number</u>	<u>Detail Amount</u>
9954710409-0001	01/20/2024		cell phones	01 2510 530 000 000	52.93
Check Number: 962093      Check Type: Check      Check Date: 02/12/2024      Vendor: WESTERNNEO      WESTERN NEBRASKA OBSERVER					Check Total: 206.10
<u>Invoice Number</u>	<u>Invoice Date</u>	<u>PO Number</u>	<u>Detail Description</u>	<u>Chart of Account Number</u>	<u>Detail Amount</u>
707061-0001	12/28/2023		PUBLIC MEETING NOTICE	01 2310 540 000 000	9.62
707300	01/18/2024		MINUTES PUBLISHED	01 2310 540 000 000	177.24
707303	01/18/2024		MEETING NOTICE WORK SESSION	01 2310 540 000 000	9.62
707449-0001	02/01/2024		LEGAL NOTICE BOARD MEETING	01 2310 540 000 000	9.62
Check Number: 962094      Check Type: Check      Check Date: 02/12/2024      Vendor: AWLASERART      AMBER WILKE					Check Total: 288.00
<u>Invoice Number</u>	<u>Invoice Date</u>	<u>PO Number</u>	<u>Detail Description</u>	<u>Chart of Account Number</u>	<u>Detail Amount</u>
3102	01/30/2024	13212	Tumblers	01 2410 610 001 000	288.00

\*Denotes Expensed Invoice Item

Checking Account ID: 01

Total without Voids: 117,791.48

**Detail Check Register**

**Checking Account: 02**

**DEPRECIATION FUND 02-101**

Check Number: 1261	Check Type: Check	Check Date: 02/12/2024	Vendor: KIDWELL	KIDWELL	Check Total:	1,260.00
<u>Invoice Number</u>	<u>Invoice Date</u>	<u>PO Number</u>	<u>Detail Description</u>	<u>Chart of Account Number</u>	<u>Detail Amount</u>	
23118	02/07/2024	13171	2 eIDC - PoE network door controller sup	02 2900 733 000 000	1,260.00	

\*Denotes Expensed Invoice Item

Checking Account ID: 02

Total without Voids: 1,260.00

**Detail Check Register**

**Checking Account: 05**

**ACTIVITY FUND 05-101**

Check Number:	Check Type:	Check Date:	Vendor:		Check Total:
<u>Invoice Number</u>	<u>Invoice Date</u>	<u>PO Number</u>	<u>Detail Description</u>	<u>Chart of Account Number</u>	<u>Detail Amount</u>
19108	Check	02/12/2024	CASHWADIST	CASH-WA DISTRIBUTING	357.50
14064951-0001		01/08/2024		05 2900 610 001 325	217.26
14067266		01/11/2004		05 2900 610 001 325	140.24
19109	Check	02/12/2024	ACEHARDWAR	KIMBALL ACE HARDWARE	285.69
4506		02/05/2024		05 2900 610 001 220	12.96
4557-0001		01/16/2024		05 2900 610 001 220	174.14
4602		02/05/2024		05 2900 610 001 220	44.99
4626		01/24/2024		05 2900 610 001 220	14.39
4631		01/24/2024		05 2900 610 001 220	31.48
4632		01/24/2024		05 2900 610 001 220	7.73
19110	Check	02/12/2024	KIMBALLHEA	KIMBALL HEALTH SERVICES	740.96
RANDOM DRU-0002		02/29/2024		05 2900 810 001 198	740.96
19111	Check	02/12/2024	KIMBALLPUB	KIMBALL PUBLIC SCHOOLS	48.35
100-----0003		02/29/2024		05 2900 610 001 153	32.35
104		02/05/2024		05 2900 610 001 743	16.00
19112	Check	02/12/2024	MENARDS	MENARDS - SCOTTSBLUFF	1,654.33
94874		01/01/2024		05 2900 610 001 220	544.54
95147		01/06/2024		05 2900 610 001 220	1,109.79
19113	Check	02/12/2024	PANHANDLEC	PANHANDLE COOP ASSOCIATION	146.00
4338		12/15/2023		05 2900 610 001 220	52.49
727868-0001		01/05/2024		05 2900 610 001 325	12.54
727873		01/06/2024		05 2900 610 001 325	37.50
727897		01/11/2024		05 2900 610 001 325	29.59
727967		01/25/2024		05 2900 610 001 325	13.88
19114	Check	02/12/2024	PEPSICOLA	PEPSI-COLA OF WESTERN NEBRASKA	487.00
5100123438-		10/13/2023		05 2900 610 001 325	(830.65)
5100129861-0001		01/12/2024		05 2900 610 001 325	757.55
5100130387		01/19/2024		05 2900 610 001 325	498.80
5100130941		01/26/2024		05 2900 610 001 325	61.30
19115	Check	02/12/2024	PLASMACAM	PLASMACAM, INC	219.37

**Detail Check Register**

**Checking Account: 05**

**ACTIVITY FUND 05-101**

<u>Invoice Number</u>	<u>Invoice Date</u>	<u>PO Number</u>	<u>Detail Description</u>	<u>Chart of Account Number</u>	<u>Detail Amount</u>
138605	01/03/2024	13132	main wiring harness	05 2900 610 001 205	198.00
138605	01/03/2024	13132	shipping	05 2900 610 001 205	21.37
Check Number: 19116      Check Type: Check      Check Date: 02/12/2024      Vendor: TEACHERSPA      TEACHERS PAY TEACHERS.COM					Check Total: 46.43
<u>Invoice Number</u>	<u>Invoice Date</u>	<u>PO Number</u>	<u>Detail Description</u>	<u>Chart of Account Number</u>	<u>Detail Amount</u>
252552071-0002	02/05/2024	13119	Curriculum resources for 2 KHS novels	05 2900 610 001 270	27.49
252552071-0002	02/05/2024	13119	Curriculum resources for 2 KHS novels	05 2900 610 001 270	15.95
252552071-0002	02/05/2024	13119	Processing fee	05 2900 610 001 270	2.99
V*252552071-0002	02/12/2024	13119	Curriculum resources for 2 KHS novels	05 2900 610 001 270	(27.49)
V*252552071-0002	02/12/2024	13119	Curriculum resources for 2 KHS novels	05 2900 610 001 270	(15.95)
V*252552071-0002	02/12/2024	13119	Processing fee	05 2900 610 001 270	(2.99)
Check Number: 19117      Check Type: Check      Check Date: 02/12/2024      Vendor: VINCESCORN      VINCE'S CORNER					Check Total: 73.98
<u>Invoice Number</u>	<u>Invoice Date</u>	<u>PO Number</u>	<u>Detail Description</u>	<u>Chart of Account Number</u>	<u>Detail Amount</u>
2024-01-05/06 PIZZA	01/16/2024	13130	Pizza for Refs - 1/5/24	05 2900 610 001 100	16.99
2024-01-05/06 PIZZA	01/16/2024	13130	Pizza for refs - 1/6/24	05 2900 610 001 100	16.99
811	01/24/2024	13189	student of the quarter lunch 2nd qtr	05 2900 890 000 000	40.00
V*2024-01-05/06 PIZZ	02/12/2024	13130	Pizza for Refs - 1/5/24	05 2900 610 001 100	(16.99)
V*2024-01-05/06 PIZZ	02/12/2024	13130	Pizza for refs - 1/6/24	05 2900 610 001 100	(16.99)
V*811	02/12/2024	13189	student of the quarter lunch 2nd qtr	05 2900 890 000 000	(40.00)
Check Number: 19118      Check Type: Check      Check Date: 02/12/2024      Vendor: WNCCCOUGAR      WNCC COUGAR BOOKSTORE					Check Total: 2,088.92
<u>Invoice Number</u>	<u>Invoice Date</u>	<u>PO Number</u>	<u>Detail Description</u>	<u>Chart of Account Number</u>	<u>Detail Amount</u>
0306875-1	01/24/2024	13177	books	05 2900 610 001 762	2,088.92
V*0306875-1	02/12/2024	13177	books	05 2900 610 001 762	(2,088.92)
Check Number: 919117      Check Type: Check      Check Date: 02/12/2024      Vendor: VINCESCORN      VINCE'S CORNER					Check Total: 73.98
<u>Invoice Number</u>	<u>Invoice Date</u>	<u>PO Number</u>	<u>Detail Description</u>	<u>Chart of Account Number</u>	<u>Detail Amount</u>
PIZZA REF JAN 2024	02/07/2024	13130	Pizza for Refs - 1/5/24	05 2900 610 001 100	16.99
PIZZA REF JAN 2024	02/07/2024	13130	Pizza for refs - 1/6/24	05 2900 610 001 100	16.99
PIZZA REF JAN 2024	02/07/2024	13130	STUDENT OF THE QTR	05 2900 890 000 000	40.00
Check Number: 919118      Check Type: Check      Check Date: 02/12/2024      Vendor: WNCCCOUGAR      WNCC COUGAR BOOKSTORE					Check Total: 2,088.92
<u>Invoice Number</u>	<u>Invoice Date</u>	<u>PO Number</u>	<u>Detail Description</u>	<u>Chart of Account Number</u>	<u>Detail Amount</u>
0306875-1-	01/24/2024	13177	books	05 2900 610 001 762	2,088.92

\*Denotes Expensed Invoice Item

Checking Account ID: 05

Total without Voids: 6,102.10

Detail Check Register

Checking Account: 06

SCHOOL NUTRITUION FUND 06-101

Invoice Number	Invoice Date	PO Number	Detail Description	Chart of Account Number	Detail Amount
14059851	01/05/2024		ML FOOD	06 3100 630 003 000	414.53
14059905	01/05/2024		HS FOOD	06 3100 630 001 000	325.89
14064841	01/08/2024		ML SUPPLIES	06 3100 610 003 000	146.70
14064841	01/08/2024		CLASSROOM SNACKS	06 3100 630 003 000	587.70
14064841	01/08/2024		ML FOOD	06 3100 630 003 000	489.50
14064857	01/08/2024		HS SUPPLIES	06 3100 610 001 000	44.36
14064857	01/08/2024		HS FOOD	06 3100 630 001 000	531.20
14071436	01/15/2024		ML SUPPLIES	06 3100 610 003 000	151.15
14071436	01/15/2024		ML CLASSROOM SNACKS	06 3100 610 003 000	138.12
14071436	01/15/2024		DISTRICT	06 3100 630 000 000	28.85
14071436	01/15/2024		ML FOOD	06 3100 630 003 000	1,406.83
14071472	01/15/2024		HS SUPPLIES	06 3100 610 001 000	44.80
14071472	01/15/2024		DISTRICT	06 3100 630 000 000	16.42
14071472	01/15/2024		HS FOOD	06 3100 630 001 000	1,626.75
14079226	01/22/2024		ML SUPPLIES	06 3100 610 003 000	46.80
14079226	01/22/2024		ML FOOD	06 3100 630 003 000	664.80
14079233	01/22/2024		HS SUPPLIES	06 3100 610 001 000	45.55
14079233	01/22/2024		HS FOOD	06 3100 630 001 000	591.99
14086833	01/29/2024		ML FOOD	06 3100 610 003 000	1,701.25
14086833	01/29/2024		ML SUPPLIES	06 3100 610 003 000	161.70
14086887	01/29/2024		HS FOOD	06 3100 630 001 000	1,367.48
C14079226	01/22/2024		ML CREDIT	06 3100 630 003 000	44.00
C14079233	01/22/2024		HS FOOD	06 3100 630 003 000	(11.89)

Check Number: 6245

Check Type: Check

Check Date: 02/12/2024

Vendor: HILANDDAIR

HILAND DAIRY FOODS COMPANY, LLC

Check Total:

2,945.44

Invoice Number	Invoice Date	PO Number	Detail Description	Chart of Account Number	Detail Amount
1719130	01/03/2024		ML MILK DELIVERY	06 3100 630 003 000	450.75
1719131	01/03/2024		HS MILK DELIVERY	06 3100 630 001 000	213.84
1719132	01/03/2024		HS MILK DELIVERY	06 3100 630 001 000	(43.55)
1719270	01/09/2024		ML MILK DELIVERY	06 3100 630 003 000	345.80
1719271	01/09/2024		HS MILK DELIVERY	06 3100 630 001 000	43.55
1719334	01/12/2024		ML MILK DELIVERY	06 3100 630 003 000	257.39
1719337	01/12/2024		ML MILK DELIVERY	06 3100 630 003 000	43.59
1719406	01/12/2024		ML MILK DELIVERY	06 3100 630 003 000	128.04
1719407	01/16/2024		HS MILK DELIVERY	06 3100 630 001 000	215.14
1719486-	01/19/2024		ML MILK DELIVERY	06 3100 630 003 000	104.96
1719568	01/23/2024		ML MILK DELIVERY	06 3100 630 003 000	258.69
1719569	01/23/2024		HS MILK DELIVERY	06 3100 630 001 000	193.37
1719640	01/26/2024		ML MILK DELIVERY	06 3100 630 003 000	238.22
1719717	01/30/2024		ML MILK DELIVERY	06 3100 630 003 000	235.61

**Detail Check Register**

<b>Checking Account:</b>	<b>06</b>	<b>SCHOOL NUTRITUION FUND 06-101</b>				
1719718	01/30/2024		HS MILK DELIVERY	06 3100 630 001 000	260.04	
Check Number: 6246	Check Type: Check	Check Date: 02/12/2024	Vendor: INFINITEC2	INFINITE CAMPUS	Check Total: 458.00	
<u>Invoice Number</u>	<u>Invoice Date</u>	<u>PO Number</u>	<u>Detail Description</u>	<u>Chart of Account Number</u>	<u>Detail Amount</u>	
SRVINV033790	11/29/2023	12904	POS pin pads	06 3100 733 003 000	458.00	
Check Number: 6247	Check Type: Check	Check Date: 02/12/2024	Vendor: PEPSICOLA	PEPSI-COLA OF WESTERN NEBRASKA	Check Total: 1,785.00	
<u>Invoice Number</u>	<u>Invoice Date</u>	<u>PO Number</u>	<u>Detail Description</u>	<u>Chart of Account Number</u>	<u>Detail Amount</u>	
5100129355	01/05/2024		PEPSI DELIVERY	06 3100 630 001 000	406.65	
5100129860	01/12/2024		PEPSI DELIVERY	06 3100 630 001 000	395.25	
5100130386	01/19/2024		PEPSI DELIVERY	06 3100 630 001 000	316.95	
5100130940	01/26/2024		PEPSI DELIVERY	06 3100 630 001 000	666.15	
Check Number: 6248	Check Type: Check	Check Date: 02/12/2024	Vendor: USFOODSGRA	US FOODS - GRAND ISLAND	Check Total: 8,448.65	
<u>Invoice Number</u>	<u>Invoice Date</u>	<u>PO Number</u>	<u>Detail Description</u>	<u>Chart of Account Number</u>	<u>Detail Amount</u>	
4518077	01/15/2024		ML SUPPLIES	06 3100 610 003 000	65.41	
4518077	01/15/2024		ML FOOD	06 3100 630 003 000	1,913.52	
4518078	01/15/2024		DISTRICT	06 3100 630 000 000	35.86	
4518078	01/15/2024		HS FOOD	06 3100 630 001 000	1,790.15	
4857719	01/29/2024		ML SUPPLIES	06 3100 610 003 000	44.97	
4857719	01/29/2024		DISTRICT FOOD	06 3100 630 000 000	98.05	
4857719	01/29/2024		ML FOOD	06 3100 630 003 000	2,247.59	
4857720	01/29/2024		HS FOOD	06 3100 630 001 000	2,227.13	
4857720	01/29/2024		HS SUPPLIES	06 3100 630 001 000	25.97	

\*Denotes Expensed Invoice Item

Checking Account ID: 06

Total without Voids: 24,201.57

**Detail Check Register**

**Checking Account: 08**

**BUILDING FUND 08-101**

Check Number: 1559	Check Type: Check	Check Date: 02/12/2024	Vendor: BOKFINANCI	BOKF, NA	Check Total:	250,958.75
<u>Invoice Number</u>	<u>Invoice Date</u>	<u>PO Number</u>	<u>Detail Description</u>	<u>Chart of Account Number</u>	<u>Detail Amount</u>	
2ND PAYMENT PRINCIPA	01/24/2024		DEBT SERVICE- PRINCIPAL PAYMENTS	08 5000 831 000 000	250,958.75	
Check Number: 1560	Check Type: Check	Check Date: 02/12/2024	Vendor: ACEHARDWAR	KIMBALL ACE HARDWARE	Check Total:	103.70
<u>Invoice Number</u>	<u>Invoice Date</u>	<u>PO Number</u>	<u>Detail Description</u>	<u>Chart of Account Number</u>	<u>Detail Amount</u>	
4488	01/08/2024		GYM PRESS BOX	08 4700 720 000 000	103.70	
Check Number: 1561	Check Type: Check	Check Date: 02/12/2024	Vendor: KIMBALLPUB	KIMBALL PUBLIC SCHOOLS	Check Total:	968.32
<u>Invoice Number</u>	<u>Invoice Date</u>	<u>PO Number</u>	<u>Detail Description</u>	<u>Chart of Account Number</u>	<u>Detail Amount</u>	
110	01/29/2024		GYM PRESS BOX	08 4700 720 000 000	968.32	

\*Denotes Expensed Invoice Item

Checking Account ID: 08

Total without Voids: 252,030.77



## KIMBALL PUBLIC SCHOOLS

Administration Offices  
 901 South Nadine Street  
 Kimball, NE 69145

Mr. Trevor Anderson, Superintendent	(308) 235-2188
Carmela Graves, Business Manager	Fax (308) 235-3269

February 12, 2024

Treasurer's report is as follows:

	Feb-24	Feb-23
Amount received from County Treasurer	688,203.16	765,234.62
Bank Balance <span style="float: right;">January 31,2024</span>	250,075.43	79,183.11
Savings Account General Funds <span style="float: right;">January 31,2024</span>	2,131,058.62	2,293,877.69
Depreciation Fund <span style="float: right;">January 31,2024</span>	396,318.00	470,965.46
Building Fund <span style="float: right;">January 31,2024</span>	585,944.22	707,597.13
Nutrition Fund <span style="float: right;">January 31,2024</span>	82,934.62	112,754.77
Activity Fund <span style="float: right;">January 31,2024</span>	97,963.76	77,552.43
<b>Total Available Funds</b>	<b>3,544,294.65</b>	<b>3,741,930.59</b>
Payroll Gross	341,733.02	318,123.87
Amount of Bills	395,283.82	382,316.37
Blue Cross Blue Shield/HSA Pmt/UNUM Life	92,183.06	110,787.14
Nebraska School Retirement	32,644.90	30,422.98
FirsTier Bank (FICA)	25,586.52	23,658.61
<b>Total Amount of Expenses</b>	<b>887,431.32</b>	<b>865,308.97</b>
<b>Balance Remaining after Expenses</b>	<b>2,656,863.33</b>	<b>2,876,621.62</b>

Monthly Finance Report to the Board

Feb-24

<b>**Reconciled Balances as of JANUARY 31, 2024</b>		
(Balance on Books)		
	2022-2023	2023-2024
General - Checking	\$ 79,183.11	\$ 250,075.43
General - Savings	\$ 2,293,877.69	\$ 2,131,058.62
Depreciation	\$ 470,965.46	\$ 396,318.00
Activity	\$ 77,552.43	\$ 97,963.76
Nutrition	\$ 112,754.77	\$ 82,934.62
Spec Building	\$ 707,597.13	\$ 585,944.22
<b>FUNDS TOTAL</b>	<b>\$ 3,741,930.59</b>	<b>\$ 3,544,294.65</b>

<b>FEBRUARY GF EXPENDITURES</b>		
	2022-2023	2023-2024
GF Bills Payable	\$ 98,006.29	\$ 117,791.48
GF Payroll	\$ 470,771.36	\$ 479,763.35
(including Ins, RET & Tax)	<b>\$ 568,777.65</b>	<b>\$ 597,554.83</b>
<b>JANUARY REVENUE</b>		
Beginning Cash	\$ 128,419.46	\$ 312,632.14
GF Transfer	\$ 300,000.00	\$ 350,000.00
State Aid	\$ 205,489.00	\$ 202,814.61
Kimball County	\$ 765,234.62	\$ 688,203.16
Interest	\$ 7,054.45	\$ 8,761.57
<b>Total Month Available</b>	<b>\$ 1,406,197.53</b>	<b>\$ 1,562,411.48</b>

<b>Three Year Comparison</b>			
<b>GF Revenue</b>			
	2021-2022	2022-2023	2023-2024
September	\$ 1,856,081.18	\$ 1,742,904.71	\$ 1,755,327.15
October	\$ 280,137.01	\$ 174,086.98	\$ 276,514.37
November	\$ 103,078.48	\$ 119,263.73	\$ 174,307.86
December	\$ 201,805.61	\$ 134,113.69	\$ 274,775.16
January	\$ 862,650.98	\$ 980,978.07	\$ 899,830.06
February	\$ 419,359.54	\$ 697,558.26	
March	\$ 402,894.18	\$ 371,544.17	
April	\$ 219,875.66	\$ 361,418.71	
May	\$ 2,270,649.87	\$ 1,679,707.69	
June	\$ 600,914.46	\$ 651,665.08	
July	\$ 220,095.13	\$ 97,061.37	
August	\$ 264,327.29	\$ 117,420.86	
<b>Running Total (YTD)</b>	<b>\$ 3,303,753.26</b>	<b>\$ 3,151,347.18</b>	<b>\$ 3,380,754.60</b>
<b>Total Revenue</b>	<b>\$ 7,701,869.39</b>	<b>\$ 7,127,723.32</b>	<b>\$ 3,380,754.60</b>
<b>% OF BUD (YTD)</b>	<b>45.77%</b>	<b>43.66%</b>	<b>44.01%</b>
Annual Budget	\$ 7,501,033.00	\$ 7,217,500.00	\$ 7,682,000.00
% of Bud Rec	102.68%	98.76%	44.01%

<b>FEBRUARY NUTRITION FUND</b>		
	2022-2023	2023-2024
NF Bills Payable	\$ 21,862.67	\$ 24,201.57
NF Payroll	\$ 8,484.62	\$ 11,146.42
	<b>\$ 30,347.29</b>	<b>\$ 35,347.99</b>
<b>JANUARY REVENUE</b>		
Beginning Cash	\$ 111,393.12	\$ 85,575.53
LUNCH INFINITE CAMPUS	\$ 5,306.34	\$ 9,166.48
SFSP Lunch Claim	\$ 10,467.11	\$ 13,701.12
Checks	\$ 6,826.52	\$ 5,940.09
INTEREST	\$ 362.31	\$ 349.86
	<b>\$ 134,355.40</b>	<b>\$ 114,733.08</b>

<b>Three Year Comparison</b>			
<b>GF Expenditures</b>			
	2021-2022	2022-2023	2023-2024
September	\$ 619,836.07	\$ 620,981.51	\$ 653,383.62
October	\$ 523,352.74	\$ 533,968.42	\$ 565,759.67
November	\$ 554,319.21	\$ 577,418.34	\$ 641,858.85
December	\$ 566,973.73	\$ 548,958.90	\$ 574,717.65
January	\$ 501,526.94	\$ 515,206.81	\$ 524,429.42
February	\$ 548,304.59	\$ 571,713.07	
March	\$ 531,266.35	\$ 544,625.81	
April	\$ 968,021.51	\$ 559,954.31	
May	\$ 716,429.52	\$ 608,072.01	
June	\$ 565,530.15	\$ 560,529.78	
July	\$ 643,475.88	\$ 476,687.88	
August	\$ 433,623.09	\$ 649,809.34	
<b>Running Total (YTD)</b>	<b>\$ 2,766,008.69</b>	<b>\$ 2,796,533.98</b>	<b>\$ 2,960,149.21</b>
<b>Total Expenditures</b>	<b>\$ 7,172,659.78</b>	<b>\$ 6,767,926.18</b>	<b>\$ 2,960,149.21</b>
<b>% of Bud Spent (YTD)</b>	<b>29.58%</b>	<b>29.04%</b>	<b>29.81%</b>
Annual Budget	\$ 9,350,752.00	\$ 9,629,521.00	\$ 9,928,634.00
<b>% of Bud Spent</b>	<b>76.71%</b>	<b>70.28%</b>	<b>29.81%</b>



**BOARD BUDGET REPORT OF REVENUES**

Acct #	Acct Description	Current Mo	YTD	Budget	% of Budget	Prev Yr Mo	Prev YTD	Prev Budget	Prev % of Budget
		1,677.56	10,032.46	215,000.00	4.67	1,553.46	6,286.80	200,000.00	3.14
02	DEPRECIATION FUND	1,677.56	10,032.46	215,000.00	4.67	1,553.46	6,286.80	200,000.00	3.14
05	ACTIVITIES								
05 1510 0500	HS MISCELLANEOUS FUND	211.37	838.70	0.00	0.00	0.00	0.00	0.00	0.00
05 1510 0502	HS INTEREST EARNED ON ACCOUNT	908.22	2,599.04	2,000.00	129.95	264.25	1,073.76	0.00	0.00
05 1710 0000	ADMISSIONS	0.00	0.00	0.00	0.00	0.00	0.00	0.00	0.00
05 1710 0100	ATHLETIC FUND	0.00	287.24	5,000.00	5.74	0.00	(8.00)	25,000.00	(0.03)
05 1710 0101	ACTIVITY TICKETS	0.00	1,685.00	5,000.00	33.70	0.00	165,866.84	3,000.00	5,528.89
05 1710 0110	FB GATE RECEIPTS	0.00	2,432.75	3,000.00	81.09	0.00	2,482.00	4,000.00	62.05
05 1710 0120	VB GATE RECEIPTS	0.00	1,791.75	2,000.00	89.59	0.00	1,439.00	3,000.00	47.97
05 1710 0140	BBB/GBB GATE RECEIPTS	1,429.67	2,091.67	5,000.00	41.83	1,383.00	3,852.00	6,000.00	64.20
05 1710 0150	WR GATE RECEIPTS	0.00	0.00	0.00	0.00	0.00	0.00	0.00	0.00
05 1710 0160	TR GATE RECEIPTS	0.00	0.00	2,000.00	0.00	0.00	0.00	1,000.00	0.00
05 1710 0180	JH FOOTBALL ADMISSIONS	0.00	109.00	1,000.00	10.90	0.00	1,360.75	1,000.00	136.08
05 1710 0181	JH VOLLEYBALL ADMISSIONS	0.00	323.00	500.00	64.60	0.00	226.00	1,000.00	22.60
05 1710 0182	JH BASKETBALL ADMISSIONS	173.00	772.00	1,000.00	77.20	302.00	974.00	1,000.00	97.40
05 1710 0183	JH WRESTLING ADMISSIONS	0.00	310.00	1,000.00	31.00	0.00	346.00	1,000.00	34.60
05 1790 000	OTHER STUDENT ACTIVITY INCOME	0.00	0.00	0.00	0.00	0.00	0.00	0.00	0.00
05 1790 0100	ATHLETIC FUND	0.00	0.00	0.00	0.00	0.00	0.00	0.00	0.00
05 1790 0130	XC ENTRY FEES	0.00	640.00	1,000.00	64.00	0.00	880.00	500.00	176.00
05 1790 0170	BOYS GOLF ENTRY FEES	0.00	0.00	0.00	0.00	0.00	0.00	350.00	0.00
05 1790 0176	GIRLS GOLF ENTRY FEES	0.00	50.00	500.00	10.00	0.00	340.00	350.00	97.14
05 1790 0183	JH WRESTLING FEES	0.00	675.00	0.00	0.00	0.00	600.00	0.00	0.00
05 1790 0184	JH TRACK FEES	0.00	0.00	500.00	0.00	0.00	0.00	1,000.00	0.00
05 1790 0210	PADLOCK DEPOSITS	0.00	71.00	250.00	28.40	0.00	235.00	250.00	94.00
05 1790 0211	BOOK FINES/FEES	0.00	0.00	0.00	0.00	0.00	0.00	500.00	0.00
05 1790 0701	FFA FUND	0.00	0.00	30,000.00	0.00	0.00	60.00	0.00	0.00
05 1920 000	DONATIONS & SPONSORSHIPS	0.00	9.00	0.00	0.00	0.00	0.00	0.00	0.00
05 1920 0205	FFA PLASMAMACAM FUND	0.00	0.00	500.00	0.00	0.00	0.00	1,000.00	0.00
05 1920 0209	POP FUND	0.00	0.00	0.00	0.00	0.00	0.00	0.00	0.00
05 1920 0218	HS STUDENT COUNCIL	0.00	0.00	0.00	0.00	0.00	0.00	250.00	0.00
05 1920 0219	NATIONAL HONOR SOCIETY	0.00	0.00	0.00	0.00	0.00	0.00	0.00	0.00
05 1920 0222	BACKPACK FOOD PROGRAM	0.00	0.00	0.00	0.00	0.00	0.00	0.00	0.00
05 1920 0225	ONE ACTS	0.00	0.00	0.00	0.00	0.00	0.00	0.00	0.00
05 1920 0255	SANTA'S ELVES DONATION FUND	0.00	0.00	0.00	0.00	0.00	0.00	0.00	0.00
05 1920 0260	HS QUIZ BOWL	0.00	0.00	500.00	0.00	0.00	0.00	500.00	0.00
05 1920 0265	JH QUIZ BOWL	0.00	0.00	500.00	0.00	0.00	0.00	0.00	0.00



**BOARD BUDGET REPORT OF REVENUES**

Acct #	Acct Description	Current Mo	YTD	Budget	% of Budget	Prev Yr Mo	Prev YTD	Prev Budget	Prev % of Budget
0320									
05 1990 0321	CLASS OF 2021	0.00	0.00	0.00	0.00	0.00	0.00	0.00	0.00
05 1990 0322	CLASS OF 2022	0.00	0.00	0.00	0.00	0.00	0.00	0.00	0.00
05 1990 0323	CLASS OF 2023	0.00	74.45	0.00	0.00	0.00	0.00	0.00	0.00
05 1990 0324	CLASS OF 2024	0.00	0.00	1,000.00	0.00	748.40	1,931.50	0.00	0.00
05 1990 0325	CLASS OF 2025	1,219.10	8,978.68	20,000.00	44.89	0.00	0.00	0.00	0.00
05 1990 0326	CLASS OF 2026	0.00	717.80	0.00	0.00	0.00	0.00	0.00	0.00
05 1990 0400	GRADE ACTIVITY MISCELLANEOUS	281.59	2,281.59	500.00	456.32	85.00	178.75	1,000.00	17.88
05 1990 0410	GRADE ACTIVITY LEADERSHIP FUND	0.00	371.78	0.00	0.00	0.00	0.00	0.00	0.00
05 1990 0450	JANICEK STOCK MARKET FUNDRAISER	0.00	0.00	0.00	0.00	0.00	0.00	0.00	0.00
05 1990 0500	HS MISCELLANEOUS FUND	110.94	1,160.94	500.00	232.19	0.00	115,500.58	1,000.00	11,550.06
05 1990 0501	HS HONOR ROLL CERTIFICATES	0.00	(74.45)	0.00	0.00	0.00	0.00	0.00	0.00
05 1990 0601	BAND ACTIVITY	0.00	560.00	1,500.00	37.33	0.00	440.00	1,500.00	29.33
05 1990 0602	SCHOOL INSTRUMENT & REPAIRS	0.00	0.00	0.00	0.00	0.00	0.00	500.00	0.00
05 1990 0603	CHORUS	0.00	0.00	0.00	0.00	0.00	0.00	500.00	0.00
05 1990 0606	SHOW CHOIR UNIFORMS	0.00	3,905.00	5,500.00	71.00	0.00	3,792.00	5,000.00	75.84
05 1990 0607	ELEM SHOW CHOIR	0.00	337.00	0.00	0.00	0.00	160.00	1,000.00	16.00
05 1990 0701	FFA FUND	0.00	0.00	0.00	0.00	0.00	77.50	0.00	0.00
05 1990 0703	JH CONCESSIONS	0.00	0.00	0.00	0.00	0.00	0.00	0.00	0.00
05 1990 0705	CHEERLEADING FUNDRAISING	0.00	9,972.85	25,000.00	39.89	1,110.00	4,769.57	20,000.00	23.85
05 1990 0707	INTERACT CLUB	0.00	0.00	0.00	0.00	0.00	0.00	0.00	0.00
05 1990 0709	JH STUDENT COUNCIL	0.00	0.00	100.00	0.00	0.00	94.00	0.00	0.00
05 1990 0711	HS STUCO FUNDRAISER	0.00	0.00	500.00	0.00	0.00	335.00	2,000.00	16.75
05 1990 0713	NATIONAL HONOR SOCIETY FUNDRAISER	411.00	411.00	500.00	82.20	198.50	198.50	500.00	39.70
05 1990 0715	XC FUNDRAISING	0.00	1,092.00	1,500.00	72.80	0.00	0.00	2,000.00	0.00
05 1990 0717	BOYS GOLF FUNDRAISING	0.00	500.00	1,500.00	33.33	0.00	120.00	1,000.00	12.00
05 1990 0719	GIRLS GOLF FUNDRAISING	0.00	190.00	1,500.00	12.67	0.00	100.00	1,000.00	10.00
05 1990 0721	FB FUNDRAISING	0.00	1,175.00	10,000.00	11.75	30.00	1,392.81	10,000.00	13.93
05 1990 0723	VOLLEYBALL FUNDRAISER	0.00	565.00	10,000.00	5.65	0.00	1,211.80	15,000.00	8.08
05 1990 0725	BBB FUNDRAISING	65.00	65.00	7,000.00	0.93	320.00	1,247.00	5,000.00	24.94
05 1990 0727	GBB FUNDRAISING	0.00	318.00	7,000.00	4.54	0.00	5,220.00	5,000.00	104.40
05 1990 0729	WRESTLING FUNDRAISING	0.00	0.00	3,000.00	0.00	0.00	1,140.00	5,000.00	22.80
05 1990 0731	TRACK FUNDRAISING	0.00	150.00	3,000.00	5.00	0.00	0.00	1,000.00	0.00
05 1990 0735	WEIGHT LIFTING CLUB	0.00	(800.00)	7,000.00	(11.43)	0.00	0.00	0.00	0.00
05 1990 0739	STAND	0.00	0.00	0.00	0.00	0.00	0.00	0.00	0.00
05 1990 0741	ART CLASS PROJECTS	0.00	0.00	100.00	0.00	0.00	20.00	0.00	0.00
05 1990 0743	MATH CLUB	0.00	0.00	0.00	0.00	0.00	0.00	100.00	0.00

**BOARD BUDGET REPORT OF REVENUES**

Acct #	Acct Description	Current Mo	YTD	Budget	% of Budget	Prev Yr Mo	Prev YTD	Prev Budget	Prev % of Budget
05 1990 0745	SCIENCE CLUB	0.00	0.00	0.00	0.00	0.00	0.00	0.00	0.00
05 1990 0751	7-12 RESOURCE RM FUNDRAISING	54.30	54.30	0.00	0.00	0.00	0.00	0.00	0.00
05 1990 0753	SPEECH FUNDRAISING	0.00	0.00	1,000.00	0.00	0.00	0.00	2,000.00	0.00
05 1990 0755	ONE ACT FUNDRAISING	0.00	0.00	1,000.00	0.00	580.00	580.00	1,000.00	58.00
05 1990 0757	LONGHORNS COMMITTED	0.00	200.00	1,000.00	20.00	0.00	0.00	0.00	0.00
05 1990 0759	CIVICS FUNDRAISER	0.00	0.00	2,500.00	0.00	0.00	476.00	0.00	0.00
05 1990 0761	KIMBALL PREVENTION COALITION	0.00	0.00	0.00	0.00	742.00	742.00	0.00	0.00
05 1990 0762	EDUCATION QUEST	0.00	2,500.00	2,500.00	100.00	0.00	2,500.00	2,000.00	125.00
05 1990 0764	LONGHORN APPAREL	0.00	168.00	1,000.00	16.80	437.00	895.00	2,000.00	44.75
05 5200	TRANSFERS FROM OTHER FUNDS	0.00	0.00	0.00	0.00	0.00	0.00	74,726.00	0.00
05 5200 0201	TRANSFER ACCOUNT	0.00	0.00	0.00	0.00	0.00	0.00	25,000.00	0.00
		<u>14,502.49</u>	<u>70,433.07</u>	<u>218,450.00</u>	<u>32.24</u>	<u>11,107.50</u>	<u>63,127.94</u>	<u>307,526.00</u>	<u>20.53</u>
05	ACTIVITIES	14,502.49	70,433.07	218,450.00	32.24	11,107.50	63,127.94	307,526.00	20.53
06	SCHOOL NUTRITION								
06 1510	INTEREST ON LOCAL REV RECEIPTS	349.86	1,775.29	4,000.00	44.38	362.31	1,021.85	0.00	0.00
06 1611	STUDENT LUNCHES	15,106.57	67,899.21	110,000.00	61.73	12,132.86	49,737.67	75,000.00	66.32
06 1612	STUDENT BREAKFASTS	0.00	0.00	0.00	0.00	0.00	0.00	0.00	0.00
06 1613	SPECIAL MILK PROGRAM	0.00	0.00	0.00	0.00	0.00	0.00	0.00	0.00
06 1620	FOOD PROGRAM ADULT RECEIPTS	0.00	0.00	0.00	0.00	0.00	0.00	0.00	0.00
06 1990	OTHER LOCAL RECEIPTS	0.00	0.00	0.00	0.00	0.00	0.00	0.00	0.00
06 3150	SCHOOL LUNCH-STATE SHARE	0.00	9,816.77	210,000.00	4.67	10,467.11	94,864.40	139,467.00	68.02
06 3990	OTHER STATE RECEIPTS	0.00	0.00	0.00	0.00	0.00	0.00	0.00	0.00
06 4210	SCHOOL LUNCH (FED ONLY)	13,701.12	76,242.47	0.00	0.00	0.00	0.00	130,000.00	0.00
06 5200	TRANSFERS FROM OTHER FUNDS	0.00	0.00	0.00	0.00	0.00	0.00	0.00	0.00
		<u>29,157.55</u>	<u>155,733.74</u>	<u>324,000.00</u>	<u>48.07</u>	<u>22,962.28</u>	<u>145,623.92</u>	<u>344,467.00</u>	<u>42.28</u>
06	SCHOOL NUTRITION	29,157.55	155,733.74	324,000.00	48.07	22,962.28	145,623.92	344,467.00	42.28
08	SPECIAL BUILDING FUND								
08 1100	PROPERTY TAX COMMISSION	58,664.96	193,696.28	420,000.00	46.12	53,400.96	197,264.06	410,000.00	48.11
08 1115	CARLINE TAXES	0.00	334.58	2,000.00	16.73	0.00	307.43	0.00	0.00
08 1140	PROP TAXES PENALTIES & INTEREST	194.49	663.71	2,000.00	33.19	83.41	744.28	0.00	0.00
08 1510	INTEREST ON LOCAL REV RECEIPTS	4,850.12	12,946.28	15,000.00	86.31	2,566.13	11,540.56	0.00	0.00
08 1920	CONTRIBUTIONS/DONATIONS PRIVATE	0.00	0.00	0.00	0.00	0.00	0.00	0.00	0.00
08 3130	HOMESTEAD ALLOCATION	0.00	0.00	10,000.00	0.00	0.00	0.00	0.00	0.00
08 3131	PROPERTY TAX CREDIT	0.00	0.00	30,000.00	0.00	0.00	0.00	0.00	0.00
08 3132	PROP TAX CREDIT-RAILROADS/PUBLIC SERVICE	0.00	0.00	0.00	0.00	0.00	0.00	0.00	0.00
08 3133	NAMEPLATE CAPACITY TAX	0.00	2,167.08	5,000.00	43.34	0.00	0.00	0.00	0.00
08 3180	PRO-RATA MOTOR VEHICLE	223.48	343.37	1,551.00	22.14	0.00	123.31	0.00	0.00
08 5400	LOAN PROCEEDS	0.00	0.00	0.00	0.00	0.00	0.00	0.00	0.00
		<u>63,933.05</u>	<u>210,151.30</u>	<u>485,551.00</u>	<u>43.28</u>	<u>56,050.50</u>	<u>209,979.64</u>	<u>410,000.00</u>	<u>51.21</u>
08	SPECIAL BUILDING FUND	63,933.05	210,151.30	485,551.00	43.28	56,050.50	209,979.64	410,000.00	51.21
<b>Grand Total:</b>		<b>1,009,100.71</b>	<b>3,827,105.17</b>	<b>8,925,001.00</b>	<b>42.88</b>	<b>1,072,651.81</b>	<b>3,576,365.48</b>	<b>8,479,493.00</b>	<b>42.18</b>

**BOARD BUDGET REPORT OF EXPENSES**

Object #		Current Mo	YTD	Budget	% of Budget	Prev Yr Mo	Prev YTD	Prev Budget	Prev % of Budget
01	<b>GENERAL FUND</b>								
000	AMT ABSORB UNUSED BUDGET AUTH	0.00	0.00	2,091,934.00	0.00	0.00	0.00	2,064,521.00	0.00
105	EXECUTIVE ADMINISTRATION SALARIES	10,650.00	53,250.00	130,000.00	40.96	10,000.00	50,000.00	120,000.00	41.67
110	SALARIES NON-INSTRUCTIONAL	29,452.45	167,172.01	409,000.00	40.87	30,194.12	171,673.50	375,000.00	45.78
111	SALARIES TEACHERS/PROF STAFF	222,712.29	1,114,787.49	2,863,500.00	38.93	215,429.16	1,088,619.31	2,822,000.00	38.58
112	SALARIES PARAS	19,814.40	101,398.94	272,000.00	37.28	19,840.84	115,624.80	211,000.00	54.80
114	SALARIES DIRECTOR	2,628.01	14,095.61	35,000.00	40.27	2,578.39	15,099.70	30,000.00	50.33
116	SALARIES PROFESSIONAL NON-CERTIFIED	14,680.33	73,401.65	180,000.00	40.78	14,196.49	70,982.45	171,000.00	41.51
120	SUBSTITUTE NON-INSTRUCTIONAL	0.00	158.60	2,000.00	7.93	0.00	0.00	0.00	0.00
122	SUBSTITUTES PARAS	0.00	4,095.00	0.00	0.00	480.00	720.00	0.00	0.00
123	SUBSTITUTES SALARIES - TEACHERS	11,543.30	54,056.90	110,000.00	49.14	7,795.26	44,460.28	65,000.00	68.40
126	SUBSTITUTES SALARIES - PROFESSIONAL	0.00	0.00	0.00	0.00	0.00	0.00	0.00	0.00
130	OVERTIME NON-INSTRUCTIONAL	57.68	60.69	0.00	0.00	36.67	36.67	1,000.00	3.67
132	OVERTIME PARAS	118.98	408.30	0.00	0.00	65.04	333.51	0.00	0.00
150	ADDITIONAL COMP NON-INSTRUCTIONAL	913.89	13,866.23	30,000.00	46.22	320.67	4,400.60	20,000.00	22.00
151	ADDITIONAL COMP TEACHERS/PROF STAFF	7,303.84	64,010.20	170,000.00	37.65	7,212.49	59,458.53	156,000.00	38.11
152	ADDITIONAL COMP PARAS	319.60	1,598.00	5,000.00	31.96	277.50	1,387.50	5,500.00	25.23
159	STIPENDS PAID TO DISTRICT STAFF	0.00	0.00	0.00	0.00	0.00	0.00	0.00	0.00
210	GROUP INSURANCE NON-INSTRUCTIONAL	3,373.79	19,110.40	54,600.00	35.00	3,708.45	19,372.79	57,500.00	33.69
211	GROUP INSURANCE TEACHERS/PROF STAFF	71,889.99	357,694.50	846,300.00	42.27	56,811.70	280,757.47	763,400.00	36.78
212	GROUP INSURANCE PARAS	47.50	181.83	600.00	30.31	20.33	(48.73)	550.00	(8.86)
213	GROUP INSURANCE LONG TERM SUB	676.63	3,281.54	9,500.00	34.54	626.53	2,947.84	0.00	0.00
214	GROUP INSURANCE DIRECTOR	0.00	0.00	0.00	0.00	0.00	0.00	0.00	0.00
215	GROUP INSURANCE SUPERINTENDENT	2,294.12	11,309.82	26,000.00	43.50	1,864.34	9,216.04	24,000.00	38.40
216	GROUP INSURANCE PROFESSIONAL NONCERTIFIE	6,742.27	33,258.95	77,000.00	43.19	5,553.71	27,768.55	72,000.00	38.57
220	SOCIAL SECURITY NON-INSTRUCTIONAL	2,190.41	12,033.23	27,500.00	43.76	1,639.78	9,553.51	30,000.00	31.85
221	SOCIAL SECURITY TEACHERS/PROF STAFF	17,201.97	88,246.66	248,200.00	35.55	16,630.76	85,830.48	225,500.00	38.06
222	SOCIAL SECURITY PARAS	1,549.34	8,223.78	20,600.00	39.92	1,560.86	8,914.44	17,700.00	50.36
223	SOCIAL SECURITY SUB TEACHERS	883.07	4,135.42	8,100.00	51.05	595.50	3,397.29	5,200.00	65.33
224	SOCIAL SECURITY DIRECTOR	196.57	1,055.96	3,000.00	35.20	192.77	1,132.75	3,000.00	37.76
225	SOCIAL SECURITY SUPERINTENDENT	810.62	4,053.38	10,500.00	38.60	760.89	3,804.68	9,500.00	40.05
226	SOCIAL SECURITY PROFESSIONAL NONCERTIFIE	1,102.16	5,510.80	15,000.00	36.74	1,065.16	5,325.80	13,500.00	39.45
229	SOCIAL SECURITY EARLY RETIREMENT	0.00	0.00	0.00	0.00	0.00	0.00	0.00	0.00
230	RETIREMENT NON-INSTRUCTIONAL	2,848.33	14,866.47	32,000.00	46.46	2,281.28	13,000.55	32,500.00	40.00
231	RETIREMENT TEACHERS/PROF STAFF	22,603.35	115,219.84	308,500.00	37.35	21,976.71	112,982.49	295,300.00	38.26
232	RETIREMENT PARAS	2,000.55	9,691.44	25,600.00	37.86	1,993.69	11,585.26	21,200.00	54.65
233	tax expense	485.32	2,090.79	0.00	0.00	278.08	1,610.03	0.00	0.00
234	RETIREMENT DIRECTOR	0.00	4.29	100.00	4.29	0.00	54.97	1,000.00	5.50
235	RETIREMENT SUPERINTENDENT	1,051.98	5,259.92	13,000.00	40.46	987.78	4,938.90	11,500.00	42.95
236	RETIREMENT PROFESSIONAL NONCERTIFIED	1,450.09	7,250.45	18,500.00	39.19	1,402.29	7,011.45	17,500.00	40.07
237	INCREASED RETIREMENT CONTRIBUTIONS	0.00	0.00	0.00	0.00	0.00	0.00	0.00	0.00
239	EARLY RETIREMENT	0.00	0.00	0.00	0.00	0.00	0.00	0.00	0.00
261	UNEMPLOYMENT TEACHER/PROF STAFF	0.00	0.00	2,000.00	0.00	0.00	0.00	8,000.00	0.00
270	WORKERS COMP NON-INSTRUCTIONAL	0.00	4,966.00	11,000.00	45.15	0.00	10,590.00	6,500.00	162.92
271	WORKMEN'S COMP TEACHERS/PROF STAFF	0.00	15,600.00	22,000.00	70.91	(173.00)	20,855.00	21,500.00	97.00
280	HEALTH BENEFIT PAID NON-INSTRUCTIONAL	271.05	1,832.79	5,000.00	36.66	350.88	1,753.16	4,250.00	41.25
281	HEALTH BENEFIT PAID TEACHERS/PROF STAFF	3,276.27	20,334.11	49,000.00	41.50	2,854.09	16,574.09	42,050.00	39.42
282	HEALTH BENEFIT PAID PARAS	0.00	0.07	0.00	0.00	0.00	1.24	0.00	0.00
283	HSA	105.09	541.16	0.00	0.00	0.00	0.00	0.00	0.00
286	HEALTH BENEFIT PAID PROF NON-CERTIFIED	0.00	0.00	0.00	0.00	0.00	0.00	0.00	0.00
291	OTHER BENEFITS TEACHERS/PROF STAFF	244.31	244.31	5,500.00	4.44	341.95	1,820.24	5,500.00	33.10
293	OTHER BENEFITS SUBSTITUTES	96.40	96.40	1,000.00	9.64	97.75	352.75	1,000.00	35.28
315	AUDIT	0.00	16,745.41	30,000.00	55.82	0.00	18,493.75	30,000.00	61.65
317	LEGAL SERVICES	345.60	1,891.80	25,000.00	7.57	160.00	2,049.20	25,000.00	8.20
320	PROFESSIONAL SERVICES	0.00	0.00	0.00	0.00	0.00	0.00	0.00	0.00
330	EMPLOYEE TRAINING/PROF DEVELOPMENT	0.00	2,924.70	17,500.00	18.57	277.70	7,759.48	14,000.00	55.42
332	MILEAGE TO PARENTS	0.00	592.31	4,500.00	13.16	0.00	712.52	6,000.00	11.88

**BOARD BUDGET REPORT OF EXPENSES**

Object #		Current Mo	YTD	Budget	% of Budget	Prev Yr Mo	Prev YTD	Prev Budget	Prev % of Budget
334	MILEAGE PAID TO OTHERS	189.56	2,062.56	7,500.00	35.18	0.00	2,079.76	2,000.00	103.99
340	OTHER PROFESSIONAL SERVICES	252.10	4,161.92	55,000.00	9.67	1,651.48	23,514.08	51,550.00	45.61
350	Technical services	0.00	400.00	0.00	0.00	0.00	0.00	0.00	0.00
352	other technical services	0.00	0.00	0.00	0.00	0.00	0.00	0.00	0.00
382	REIMBURSIBLE DISTANCE LEARNING	535.26	8,959.98	29,000.00	30.90	2,166.46	10,819.30	31,000.00	34.90
410	WATER AND SEWER	1,838.37	16,490.23	40,000.00	41.23	1,819.65	14,291.99	40,000.00	35.73
420	CLEANING SERVICES	6,005.00	20,555.00	0.00	0.00	0.00	0.00	0.00	0.00
430	REPAIRS & MAINTENANCE	0.00	0.00	0.00	0.00	0.00	0.00	0.00	0.00
442	RENTALS OF EQUIPMENT AND VEHICLES	0.00	0.00	0.00	0.00	0.00	0.00	0.00	0.00
443	RENTALS OF COMP AND RELATED EQUIPMENT	0.00	0.00	0.00	0.00	0.00	0.00	0.00	0.00
490	ASBESTOS ABATEMENT	0.00	0.00	1,000.00	0.00	0.00	0.00	1,000.00	0.00
520	INSURANCE OTHER THAN EMPLOYEE BENEFITS	0.00	141,368.00	130,000.00	108.74	0.00	98,743.00	100,000.00	98.74
521	FIDELITY BOND PREMIUMS	0.00	0.00	500.00	0.00	0.00	0.00	250.00	0.00
530	TELEPHONE	1,237.61	8,255.33	20,000.00	41.28	3,420.19	7,231.74	35,000.00	20.66
531	POSTAGE	0.00	103.85	2,500.00	8.23	9.35	1,309.50	2,500.00	52.38
540	ADVERTISING AND PRINTING	358.43	1,374.54	5,000.00	27.49	178.05	1,672.72	6,000.00	27.88
561	TUITION PAID TO OTHER DISTRICTS	0.00	22,870.80	87,000.00	26.29	7,323.60	29,294.40	68,000.00	43.08
569	TUITION OTHER (OUT OF STATE)	0.00	0.00	1,000.00	0.00	0.00	0.00	3,500.00	0.00
580	TRAVEL EXPENSE AND MILEAGE	343.79	10,525.68	49,600.00	23.36	545.63	6,485.72	41,250.00	15.72
591	ESU - MIPS CLERICAL	239.90	46,831.51	239,500.00	19.55	21,962.44	85,021.51	217,800.00	39.04
610	SUPPLIES	13,837.06	65,478.72	240,000.00	29.61	7,932.34	53,608.07	217,000.00	24.70
621	NATURAL GAS	13,395.03	39,669.50	105,000.00	37.78	16,045.33	39,469.72	180,000.00	21.93
626	GAS AND OIL	3,980.13	23,053.13	60,000.00	38.42	4,491.94	20,069.84	55,000.00	36.49
640	TEXTBOOKS	29.99	10,188.68	95,000.00	12.16	0.00	11,071.50	89,500.00	12.37
642	AUDIO-VISUAL MATERIALS	0.00	0.00	0.00	0.00	0.00	0.00	0.00	0.00
643	WEB/CLOUD BASED SOFTWARE	0.00	0.00	30,000.00	0.00	0.00	0.00	27,850.00	0.00
650	SUPPLIES-TECHNOLOGY RELATED	7,429.56	8,477.72	43,000.00	22.03	0.00	3,358.12	33,000.00	10.18
720	BUILDINGS AND IMPROVEMENTS	1,667.06	16,303.98	31,000.00	54.50	4,220.14	14,574.59	27,500.00	53.00
732	VEHICLE ACQUISITION	0.00	0.00	200,000.00	0.00	0.00	0.00	200,000.00	0.00
733	FURNITURE AND EQUIPMENT	391.99	48,880.84	93,000.00	57.96	2,087.02	28,901.16	74,550.00	38.77
734	COMPUTER EQUIPMENT (HARDWARE)	0.00	0.00	7,500.00	0.00	1,081.92	2,109.94	7,500.00	28.13
735	COMPUTER SOFTWARE	4,320.12	14,807.94	30,000.00	49.41	4,421.85	19,985.26	29,000.00	68.91
739	OTHER EQUIPMENT	0.00	1,500.00	0.00	0.00	0.00	0.00	0.00	0.00
805	DEBT SERVICE (CLEAN HARBORS)	0.00	0.00	0.00	0.00	0.00	0.00	0.00	0.00
807	REVALUATION OF TAXABLE PROPERTY	0.00	0.00	0.00	0.00	0.00	0.00	0.00	0.00
810	DUES AND FEES	190.00	5,132.26	27,500.00	20.16	190.00	2,080.00	23,100.00	9.00
890	OTHER MISC OBJECTS	4,256.91	12,088.89	83,500.00	15.07	3,372.81	11,793.15	60,000.00	19.66
912	TRANSFERS TO LUNCH FROM GEN FD	0.00	0.00	0.00	0.00	0.00	0.00	100,000.00	0.00
913	TRANSFERS TO ACTIVITY ACCOUNTS	0.00	0.00	0.00	0.00	0.00	0.00	100,000.00	0.00
915	OTHER TRANSFERS (DEPR FUND)	0.00	0.00	0.00	0.00	0.00	0.00	0.00	0.00
01	GENERAL FUND	524,429.42	2,960,149.21	9,928,634.00	29.99	515,206.81	2,800,399.91	9,629,521.00	29.08
02	DEPRECIATION FUND								
450	CONSTRUCTION SERVICES	0.00	32,375.00	482,512.00	6.71	1,646.18	2,946.18	500,000.00	0.59
610	SUPPLIES	0.00	0.00	0.00	0.00	0.00	0.00	0.00	0.00
732	VEHICLE ACQUISITION	0.00	187,430.43	200,000.00	93.72	0.00	94,018.00	0.00	0.00
733	FURNITURE AND EQUIPMENT	247.50	1,294.23	100,000.00	2.55	0.00	868.99	263,327.00	0.33
739	OTHER EQUIPMENT	0.00	1,272.00	0.00	0.00	0.00	0.00	0.00	0.00
02	DEPRECIATION FUND	247.50	222,371.66	782,512.00	28.58	1,646.18	97,833.17	763,327.00	12.82
05	ACTIVITIES								
352	other technical services	2,798.00	14,410.00	17,500.00	85.69	3,934.00	10,808.00	12,000.00	90.07
580	TRAVEL EXPENSE AND MILEAGE	1,630.66	12,261.25	26,500.00	57.30	0.00	3,588.88	26,500.00	13.54
610	SUPPLIES	26,834.53	101,412.13	298,000.00	37.08	23,517.89	110,213.55	255,526.00	43.13
733	FURNITURE AND EQUIPMENT	5,236.40	5,236.40	0.00	0.00	0.00	0.00	0.00	0.00
735	COMPUTER SOFTWARE	0.00	2,137.25	0.00	0.00	0.00	2,099.00	0.00	0.00
739	OTHER EQUIPMENT	0.00	0.00	0.00	0.00	0.00	0.00	0.00	0.00
810	DUES AND FEES	948.28	9,501.89	8,000.00	120.46	2,377.00	7,233.26	9,000.00	80.37
890	OTHER MISC OBJECTS	0.00	241.82	0.00	0.00	0.00	0.00	0.00	0.00
05	ACTIVITIES	37,447.87	145,200.74	350,000.00	45.12	29,828.89	133,942.69	303,026.00	44.20
06	SCHOOL NUTRITION								
110	SALARIES NON-INSTRUCTIONAL	8,605.93	43,882.82	119,000.00	36.88	7,773.27	41,411.79	110,000.00	37.65
120	SUBSTITUTE NON-INSTRUCTIONAL	0.00	0.00	0.00	0.00	0.00	0.00	1,500.00	0.00
130	OVERTIME NON-INSTRUCTIONAL	0.00	0.00	0.00	0.00	0.00	0.00	100.00	0.00
210	GROUP INSURANCE NON-INSTRUCTIONAL	839.26	4,204.30	10,500.00	40.04	756.96	3,780.40	9,400.00	40.22

**BOARD BUDGET REPORT OF EXPENSES**

Object #		Current Mo	YTD	Budget	% of Budget	Prev Yr Mo	Prev YTD	Prev Budget	Prev % of Budget
211	GROUP INSURANCE TEACHERS/PROF STAFF	0.00	0.00	0.00	0.00	0.00	0.00	0.00	0.00
220	SOCIAL SECURITY NON-INSTRUCTIONAL	645.57	3,304.00	10,500.00	31.47	583.75	3,117.31	9,400.00	33.16
221	SOCIAL SECURITY TEACHERS/PROF STAFF	0.00	0.00	0.00	0.00	0.00	0.00	0.00	0.00
230	RETIREMENT NON-INSTRUCTIONAL	671.96	6,208.64	11,500.00	53.99	682.03	4,747.47	9,400.00	50.51
231	RETIREMENT TEACHERS/PROF STAFF	0.00	0.00	0.00	0.00	0.00	0.00	59,200.00	0.00
261	UNEMPLOYMENT TEACHER/PROF STAFF	0.00	0.00	2,000.00	0.00	0.00	0.00	3,000.00	0.00
270	WORKERS COMP NON-INSTRUCTIONAL	0.00	0.00	15,000.00	0.00	0.00	0.00	4,000.00	0.00
340	OTHER PROFESSIONAL SERVICES	0.00	1,131.20	545.00	207.56	0.00	0.00	5,000.00	0.00
610	SUPPLIES	942.95	5,713.01	11,000.00	51.94	612.47	4,848.72	11,000.00	44.08
630	FOOD	18,783.27	100,867.27	210,000.00	48.03	12,366.65	93,689.86	180,000.00	52.05
733	FURNITURE AND EQUIPMENT	46.99	3,752.28	5,000.00	358.68	0.00	0.00	3,000.00	0.00
890	OTHER MISC OBJECTS	128.50	653.50	1,000.00	65.35	0.00	0.00	1,000.00	0.00
06	SCHOOL NUTRITION	30,664.43	169,717.02	396,045.00	46.43	22,775.13	151,595.55	406,000.00	37.34
08	SPECIAL BUILDING FUND								
450	CONSTRUCTION SERVICES	0.00	2,259.88	0.00	0.00	0.00	0.00	0.00	0.00
720	BUILDINGS AND IMPROVEMENTS	4,260.60	5,283.72	600,000.00	8.59	(100.00)	928,458.95	436,373.00	212.77
733	FURNITURE AND EQUIPMENT	0.00	0.00	250,293.00	0.00	0.00	0.00	1,329,000.00	0.00
830	830	0.00	0.00	0.00	0.00	0.00	0.00	0.00	0.00
831	REDEMPTION OF PRINCIPAL	0.00	0.00	0.00	0.00	0.00	0.00	0.00	0.00
832	INTEREST	0.00	0.00	0.00	0.00	0.00	0.00	0.00	0.00
08	SPECIAL BUILDING FUND	4,260.60	7,543.60	850,293.00	6.33	(100.00)	928,458.95	1,765,373.00	52.59
Grand Total:		597,049.82	3,504,982.23	12,307,484.00	29.23	569,357.01	4,112,230.27	12,867,247.00	31.96

<u>Chart of Account Number</u>	<u>Chart of Account Description</u>	<u>Beginning Balance</u>	<u>Expenses</u>	<u>Revenues</u>	<u>Balance Change</u>	<u>Balance</u>
05 704	FUND BALANCE	(72,163.53)	0.00	0.00	0.00	(72,163.53)
05 704 0100	ATHLETIC FUND	(197,579.09)	18,467.89	0.00	0.00	(216,046.98)
05 704 0101	ACTIVITY TICKETS	1,935.00	0.00	0.00	0.00	1,935.00
05 704 0107	WT ROOM SUPPLIES/EQUIP/MISC	(1,068.26)	5,236.40	0.00	0.00	(6,304.66)
05 704 0109	UNIFORMS	(26,853.14)	0.00	0.00	0.00	(26,853.14)
05 704 0110	FB GATE RECEIPTS	11,590.00	0.00	0.00	0.00	11,590.00
05 704 0111	FB OFFICIALS	(20,612.00)	0.00	0.00	0.00	(20,612.00)
05 704 0112	FB TRAVEL	(625.76)	855.66	0.00	0.00	(1,481.42)
05 704 0113	FB SUPPLIES/EQUIP/MISC	(17,238.89)	0.00	0.00	0.00	(17,238.89)
05 704 0120	VB GATE RECEIPTS	10,431.26	0.00	0.00	0.00	10,431.26
05 704 0121	VB OFFICIALS	(7,361.00)	0.00	0.00	0.00	(7,361.00)
05 704 0123	VB SUPPLIES/EQUIP/MISC	(1,612.19)	0.00	0.00	0.00	(1,612.19)
05 704 0130	XC ENTRY FEES	916.00	0.00	0.00	0.00	916.00
05 704 0133	XC SUPPLIES/EQUIP/MISC	(17,075.34)	0.00	0.00	0.00	(17,075.34)
05 704 0137	CHEERLEADING TRAVEL	(4,441.90)	0.00	0.00	0.00	(4,441.90)
05 704 0138	CHEERLEADING SUPPLIES/EQUIP/MISC	(859.95)	0.00	0.00	0.00	(859.95)
05 704 0140	BBB/GBB GATE RECEIPTS	18,462.87	0.00	1,429.67	0.00	19,892.54
05 704 0141	BBB/GBB OFFICIALS	(15,566.98)	2,798.00	0.00	0.00	(18,364.98)
05 704 0143	BBB SUPPLIES/EQUIP/MISC	(546.00)	0.00	0.00	0.00	(546.00)
05 704 0144	BASKETBALL DUES AND FEES	(173.33)	0.00	0.00	0.00	(173.33)
05 704 0150	WR GATE RECEIPTS	1,131.10	0.00	0.00	0.00	1,131.10
05 704 0151	WR OFFICIALS	(2,662.00)	0.00	0.00	0.00	(2,662.00)
05 704 0152	WR TRAVEL	(578.97)	0.00	0.00	0.00	(578.97)
05 704 0153	WR SUPPLIES/EQUIP/MISC	(1,611.47)	32.35	0.00	0.00	(1,643.82)
05 704 0154	WR DUES AND FEES	(2,335.94)	45.00	0.00	0.00	(2,380.94)
05 704 0160	TR GATE RECEIPTS	2,880.95	0.00	0.00	0.00	2,880.95
05 704 0161	TR OFFICIALS	(300.00)	0.00	0.00	0.00	(300.00)
05 704 0162	TR TRAVEL	(6,473.73)	85.00	0.00	0.00	(6,558.73)
05 704 0163	TR SUPPLIES/EQUIP/MISC	(7,109.66)	0.00	0.00	0.00	(7,109.66)
05 704 0164	TRACK DUES AND FEES	(1,346.67)	0.00	0.00	0.00	(1,346.67)
05 704 0165	JH TRACK DUES AND FEES	(1,522.50)	0.00	0.00	0.00	(1,522.50)
05 704 0170	BOYS GOLF ENTRY FEES	(1,543.30)	0.00	0.00	0.00	(1,543.30)
05 704 0172	BOYS GOLF TRAVEL	(122.01)	0.00	0.00	0.00	(122.01)
05 704 0173	BOYS GOLF SUPPLIES/EQUIP/MISC	(5,481.07)	0.00	0.00	0.00	(5,481.07)
05 704 0176	GIRLS GOLF ENTRY FEES	(1,951.17)	0.00	0.00	0.00	(1,951.17)
05 704 0178	GIRLS GOLF SUPPLIES/EQUIP/MISC	(3,822.27)	0.00	0.00	0.00	(3,822.27)
05 704 0180	JH FOOTBALL	140.27	0.00	200.00	0.00	340.27
05 704 0181	JH VOLLEYBALL	2,120.01	0.00	0.00	0.00	2,120.01

<u>Chart of Account Number</u>	<u>Chart of Account Description</u>	<u>Beginning Balance</u>	<u>Expenses</u>	<u>Revenues</u>	<u>Balance Change</u>	<u>Balance</u>
05 704 0182	JH BASKETBALL	(2,075.75)	0.00	173.00	0.00	(1,902.75)
05 704 0183	JH WRESTLING	1,209.64	75.00	0.00	0.00	1,134.64
05 704 0184	JH TRACK	(793.07)	0.00	0.00	0.00	(793.07)
05 704 0198	RANDOM DRUG TESTING	(2,983.55)	828.28	0.00	0.00	(3,811.83)
05 704 0199	STATE/NATIONAL EXPENSES	(32,385.85)	0.00	0.00	0.00	(32,385.85)
05 704 0201	TRANSFER ACCOUNT	125,054.90	0.00	0.00	0.00	125,054.90
05 704 0202	YEARBOOK	(9,464.28)	0.00	0.00	0.00	(9,464.28)
05 704 0203	VO AG PROJECT MATERIALS	(94.65)	0.00	0.00	0.00	(94.65)
05 704 0204	AG EQUIPMENT FUND	500.00	0.00	0.00	0.00	500.00
05 704 0205	FFA PLASMACAM FUND	3,901.31	219.37	0.00	0.00	3,681.94
05 704 0206	SPECIAL EDUCATION	38.61	0.00	0.00	0.00	38.61
05 704 0207	JR CLASS CONCESSION EQUIP FUND	449.44	0.00	0.00	0.00	449.44
05 704 0208	FACILITY USE	875.00	0.00	0.00	0.00	875.00
05 704 0210	PADLOCK DEPOSITS	976.45	0.00	0.00	0.00	976.45
05 704 0211	BOOK FINES/FEES	2,005.01	0.00	0.00	0.00	2,005.01
05 704 0215	SPEECH	(1,788.49)	0.00	0.00	0.00	(1,788.49)
05 704 0216	WORLD STRIDES TRIP FUND	12.38	0.00	0.00	0.00	12.38
05 704 0218	HS STUDENT COUNCIL	(2,985.88)	0.00	0.00	0.00	(2,985.88)
05 704 0219	NATIONAL HONOR SOCIETY	(875.49)	0.00	0.00	0.00	(875.49)
05 704 0220	WOODSHOP PROJECTS	(2,858.01)	336.39	3,912.06	0.00	717.66
05 704 0222	BACKPACK FOOD PROGRAM	2,979.00	0.00	0.00	0.00	2,979.00
05 704 0225	ONE ACTS	(3,404.68)	121.79	0.00	0.00	(3,526.47)
05 704 0230	MILK BREAK	559.90	0.00	0.00	0.00	559.90
05 704 0235	THE RANCH	(1,882.44)	176.47	0.00	0.00	(2,058.91)
05 704 0240	PALS MENTORING	1,446.08	0.00	0.00	0.00	1,446.08
05 704 0245	HEALTH & WELLNESS FUND	3,266.34	0.00	0.00	0.00	3,266.34
05 704 0250	DISTRICT PROJECT FUND	8,230.19	0.00	0.00	0.00	8,230.19
05 704 0255	SANTA'S ELVES DONATION FUND	62.20	0.00	0.00	0.00	62.20
05 704 0260	HS QUIZ BOWL	98.10	0.00	0.00	0.00	98.10
05 704 0265	JH QUIZ BOWL	814.56	0.00	0.00	0.00	814.56
05 704 0266	ACTIVITIES SPONSORS	67,300.00	0.00	0.00	0.00	67,300.00
05 704 0270	O'BRIEN READING CABINET	941.31	46.43	0.00	0.00	894.88
05 704 0323	CLASS OF 2023	112.49	0.00	0.00	0.00	112.49
05 704 0324	CLASS OF 2024	2,367.54	0.00	0.00	0.00	2,367.54
05 704 0325	CLASS OF 2025	2,995.24	2,043.48	6,190.34	0.00	7,142.10
05 704 0326	CLASS OF 2026	717.80	0.00	0.00	0.00	717.80
05 704 0327	CLASS OF 2027	0.00	0.00	360.00	0.00	360.00
05 704 0400	GRADE ACTIVITY MISCELLANEOUS	16,691.16	0.00	281.59	0.00	16,972.75

<u>Chart of Account Number</u>	<u>Chart of Account Description</u>	<u>Beginning Balance</u>	<u>Expenses</u>	<u>Revenues</u>	<u>Balance Change</u>	<u>Balance</u>
05 704 0410	GRADE ACTIVITY LEADERSHIP FUND	1,242.75	77.08	0.00	0.00	1,165.67
05 704 0420	GRADE ACTIVITY SPECIAL EDUCATION	323.63	0.00	0.00	0.00	323.63
05 704 0450	JANICEK STOCK MARKET FUNDRAISER	650.10	0.00	0.00	0.00	650.10
05 704 0500	HS MISCELLANEOUS FUND	(24,974.72)	0.00	322.31	0.00	(24,652.41)
05 704 0501	HS HONOR ROLL CERTIFICATES	(897.37)	0.00	0.00	0.00	(897.37)
05 704 0502	HS INTEREST EARNED ON ACCOUNT	19,495.52	0.00	908.22	0.00	20,403.74
05 704 0601	BAND ACTIVITY	2,786.08	0.00	0.00	0.00	2,786.08
05 704 0602	SCHOOL INSTRUMENT & REPAIRS	927.46	0.00	0.00	0.00	927.46
05 704 0603	CHORUS	568.14	0.00	0.00	0.00	568.14
05 704 0605	MUSICAL PRODUCTIONS	2,195.15	0.00	0.00	0.00	2,195.15
05 704 0606	SHOW CHOIR UNIFORMS	2,498.80	304.00	0.00	0.00	2,194.80
05 704 0607	ELEM SHOW CHOIR	608.54	304.00	0.00	0.00	304.54
05 704 0701	FFA FUND	25,641.11	834.00	195.00	0.00	25,002.11
05 704 0703	JH CONCESSIONS	200.00	0.00	0.00	0.00	200.00
05 704 0705	CHEERLEADING FUNDRAISING	16,265.82	2,628.00	0.00	0.00	13,637.82
05 704 0707	INTERACT CLUB	467.92	0.00	0.00	0.00	467.92
05 704 0709	JH STUDENT COUNCIL	(443.29)	0.00	0.00	0.00	(443.29)
05 704 0711	HS STUCO FUNDRAISER	1,736.74	0.00	0.00	0.00	1,736.74
05 704 0713	NATIONAL HONOR SOCIETY FUNDRAISER	662.95	0.00	411.00	0.00	1,073.95
05 704 0715	XC FUNDRAISING	2,273.60	575.00	0.00	0.00	1,698.60
05 704 0717	BOYS GOLF FUNDRAISING	2,252.34	0.00	0.00	0.00	2,252.34
05 704 0719	GIRLS GOLF FUNDRAISING	2,464.09	0.00	0.00	0.00	2,464.09
05 704 0721	FB FUNDRAISING	(229.95)	387.00	0.00	0.00	(616.95)
05 704 0723	VOLLEYBALL FUNDRAISING	3,409.16	0.00	0.00	0.00	3,409.16
05 704 0725	BBB FUNDRAISING	1,644.45	0.00	65.00	0.00	1,709.45
05 704 0727	GBB FUNDRAISING	356.28	168.00	0.00	0.00	188.28
05 704 0729	WRESTLING FUNDRAISING	779.83	750.56	0.00	0.00	29.27
05 704 0731	TRACK FUNDRAISING	3,024.46	0.00	0.00	0.00	3,024.46
05 704 0735	WEIGHT LIFTING CLUB	171.26	0.00	0.00	0.00	171.26
05 704 0737	SPORTSMANSHIP FUND	202.73	0.00	0.00	0.00	202.73
05 704 0738	ESPORTS	2.06	0.00	0.00	0.00	2.06
05 704 0739	STAND	1,216.54	0.00	0.00	0.00	1,216.54
05 704 0741	ART CLASS PROJECTS	722.08	0.00	0.00	0.00	722.08
05 704 0743	MATH CLUB	(589.18)	0.00	0.00	0.00	(589.18)
05 704 0745	SCIENCE CLUB	2.54	0.00	0.00	0.00	2.54
05 704 0747	MITCHELL SCIENCE GRANT	294.35	0.00	0.00	0.00	294.35
05 704 0749	SPANISH CLUB	68.79	0.00	0.00	0.00	68.79
05 704 0751	7-12 RESOURCE RM FUNDRAISING	(99.46)	0.00	54.30	0.00	(45.16)

Activity Fund Balance Report - Summary - Exclude Encumbrances

01/2024 - 01/2024

<u>Chart of Account Number</u>	<u>Chart of Account Description</u>	<u>Beginning Balance</u>	<u>Expenses</u>	<u>Revenues</u>	<u>Balance Change</u>	<u>Balance</u>
05 704 0753	SPEECH FUNDRAISING	1,758.62	0.00	0.00	0.00	1,758.62
05 704 0755	ONE ACT FUNDRAISING	4,804.95	0.00	0.00	0.00	4,804.95
05 704 0757	LONGHORNS COMMITTED	3,421.59	52.72	0.00	0.00	3,368.87
05 704 0759	CIVICS FUNDRAISER	941.88	0.00	0.00	0.00	941.88
05 704 0762	EDUCATION QUEST	(2,979.83)	0.00	0.00	0.00	(2,979.83)
05 704 0763	TOM SOUTHARD MEMORIAL	3,429.00	0.00	0.00	0.00	3,429.00
05 704 0764	LONGHORN APPAREL	(1,039.15)	0.00	0.00	0.00	(1,039.15)
05 704 0999	SCHOLARSHIP FUND	216,734.98	0.00	0.00	0.00	216,734.98
Fund Total: 05		105,975.19	37,447.87	14,502.49	0.00	83,029.81



# Mary Lynch Elementary School

## February 2024 - Board of Education Report

Amanda Culek

Elementary Principal / Special Education Director

### **Enrollment**

Pre-K:	20
Kindergarten	33
1st Grade	26
2nd Grade	32
3rd Grade	32
4th Grade	19
5th Grade	25
6th Grade	32
Total Enrollment	219

### **Professional Development**

Standards-Based Grading/Curriculum Work  
Committee Meetings  
District Crisis Response/Threat Assessment  
WORDS/Teach Like A Champion

### **January Recap**

January 12th: 2nd Quarter/1st Semester Awards Ceremony  
January 15th - 19th: NWEA/NSCAS Winter Testing, SpringMath Benchmark  
January Student of the Month:  
Kindergarten-3rd Grade: Theron Tabor  
4th - 6th Grade: Lacie Russell  
January Staff of the Month:  
Certified: Mellissa Mekleburg  
Certified: Tori Ingram

### **February Plan**

Caring Hearts Expectation Challenge  
Family Engagement Challenge: Longhorn Kindness Rocks  
February 14th: Progress Reports go home  
February 20th: 5th-6th Grade Digital Citizenship Assembly



Kimball Jr/Sr High School  
Principal Board Report  
February 2024

- Our current enrollment for the 23-24 School Year:

7th Grade	21
8th Grade	37
9th Grade	26
10th Grade	30
11th Grade	22
12th Grade	30
Total	166

- Connor Deboodt, Skyla Stierwalt, Hayden Sours and Wyatt Cords were selected as Student of the Week since the last board meeting.
- Ryan Shields, Gale Mueller Whitman, Travis Cook, and Jen Lopez were the guest speakers for our Sophomore Career Class since the last board meeting.
- JAG Nebraska has posted the job opening for the JAG Specialist position for the 24-25 school year.
- The new WIN Time structure seems to be working well so far. Students who need it are given extra support to complete missing assignments

and improve their grades, others attend a study hall voluntarily. The time is also used for Jazz Band and Show Choir.

- Karen Haase will be providing two separate Digital Citizenship assemblies on the morning of February 20th. One assembly for the 5th-8th graders and another for high school students.
- Staff will be attending either a coaching workshop or a full-day session at the ESU 13 Mid-Winter Conference on February 19th.
- Math Counts competed on Wednesday, February 7th. The highest ranked Kimball student was Karsyn Chesley who was ranked 17th out of approximately 70 students.
- The National Honor Society and Anatomy and Physiology students are hosting a blood drive on Tuesday, April 9th from 7:30 to noon in the gym.
- The students who were recognized for The Longhorn Way have earned a reward trip. We will be going to the Cheyenne Ice Center on February 28th.

## DISTRICT DEMOGRAPHICS

Square Miles 715

Regular Bus Routes 3

Building      Year Built   Present Use

Mary Lynch	1956	PK-6
Jr/Sr High	1965	7-12
Voc. Ag.	1978	8-12
Auto Shop	1969	9-12
Stadium	1969	PK-12

## NSCAS Performance Data

The following assessment data compares Kimball (KIM) students vs. the State (NEB) average proficiency % on the 22-23 NSCAS assessments.

22-23 Proficiency	English Language Arts	Mathematics	Science
Percentage Proficient %	KIM/NEB %	KIM/NEB %	KIM/NEB %
3rd Grade	37 / 63	58 / 58	N/A
4th Grade	52 / 55	65 / 58	N/A
5th Grade	58 / 56	53 / 65	75 / 76
6th Grade	53 / 55	53 / 57	N/A
7th Grade	70 / 54	76 / 66	N/A
8th Grade	78 / 62	65 / 61	65 / 64
11th Grade	45 / 53	38 / 41	45 / 51

## BOARD OF EDUCATION

Mr. Travis Cook	President
Ms. Jennifer Griebel	Vice President
Mr. Thomas O'Brien	Secretary
Mr. Kenneth Smith	Treasurer
Mr. Lanny Little	Member
Ms. Britni Toth	Member

## ADMINISTRATION & CABINET

Superintendent	Mr. Trevor Anderson
Principal PK-6/SPED	Mrs. Amanda Culek
Principal 7-12	Mrs. Danielle Reader
Activities Director	Mr. Darrell Howitt
Business Manager	Mrs. Carmela Graves
Technology	Mr. Travis Terrill
Food Service	Mrs. Danessa Terrill
Building & Grounds	Mr. Matthew Brown
Transportation	Mr. Waylon Lewis

## STAFF

Administrative Assistants	3
Administrators	3
Certificated Educators	41
Food Service	4
Maintenance	3
Nurse	1
Para Professionals	13
Technology	1
Transportation	6
<b>TOTAL</b>	<b>75</b>

# KIMBALL PUBLIC SCHOOLS KIMBALL, NEBRASKA

## ANNUAL REPORT TO PATRONS

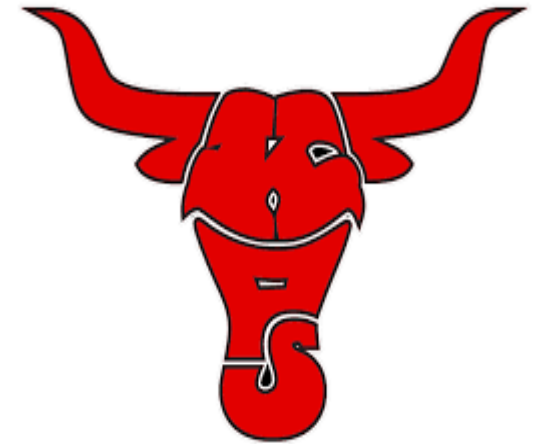

## January 2024

*The mission of Kimball Public Schools  
is to educate every student for  
a lifetime of success.*

# CONTINUOUS IMPROVEMENT

Our “Continuous Improvement Plan 2019-2024” is a living document that provides strategic direction and guidance for Kimball Public Schools. Progress on our plan is reported to the board of education at their public meeting throughout the year. To view our entire Continuous Improvement Plan, please visit our website: [www.kpslonghorns.org](http://www.kpslonghorns.org)

Current highlights in our district as a result of the Continuous Improvement Plan include:

- Marzano Instructional Strategies and Essential Standards are being incorporated into the classrooms district-wide.
- Beyond Textbooks (curriculum guides, calendars, essential standards, formative assessments) has been implemented district-wide this school year.
- Professional Development Calendar utilizing Wednesday early-outs to include: monthly PLC meetings to discuss data & Marzano, Beyond Textbooks, MTSS, & PBIS discussions, WORDS project.
- District has updated the school website ([kpslonghorns.org](http://kpslonghorns.org)), increased social media presence, implemented family nights during the school year, and created an app to keep parents and community involved. Monthly newsletters distributed to all parents at Mary Lynch.
- All students in K-12 have reading and/or math interventions every week. In addition, standards-based grading has been implemented in grades K-3.

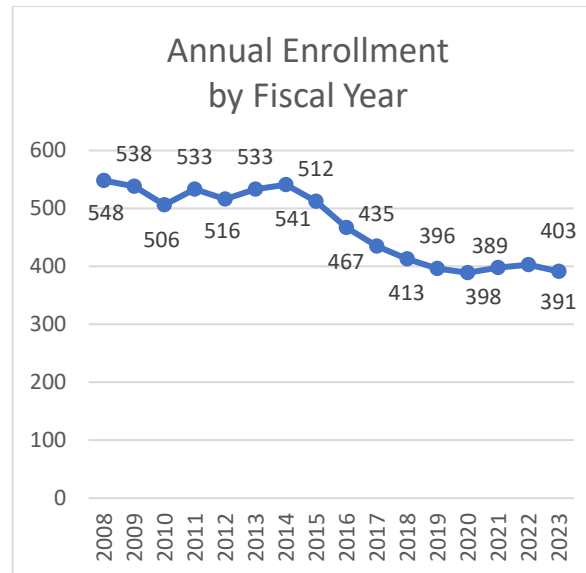
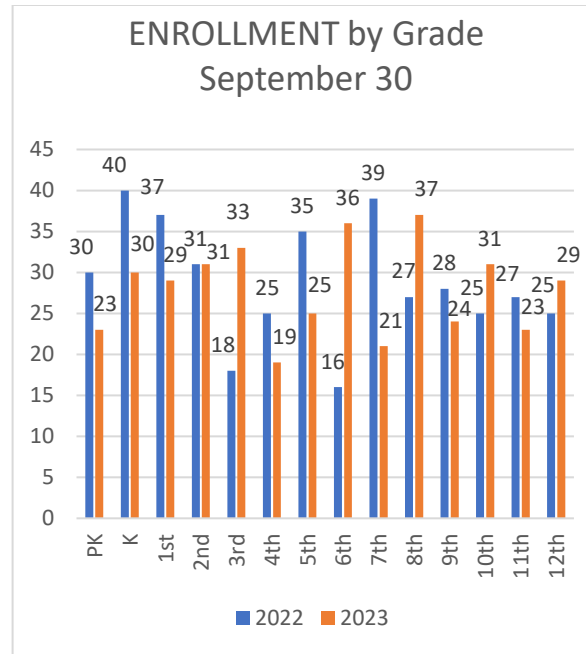

# FINANCIAL DATA (3-year comparison)

	2021-2022	2022-2023	2023-2024
<b>District Valuation</b>	<b>\$573,065,642</b>	<b>\$588,515,512</b>	<b>\$643,405,723</b>
<b>General Fund Levy</b>	<b>0.976</b>	<b>0.970</b>	<b>0.825</b>
<b>Special Building Fund Levy</b>	<b>0.074</b>	<b>0.070</b>	<b>0.075</b>
<b>Prop. Tax Generated for All Funds</b>	<b>\$6,017,192</b>	<b>\$6,120,561</b>	<b>\$5,790,652</b>
<b>Budget of General Fund Expenditures</b>	<b>\$9,350,752</b>	<b>\$9,629,521</b>	<b>\$9,928,634</b>
<b>Budget of Special Building Fund</b>	<b>\$999,657</b>	<b>\$1,765,373</b>	<b>\$850,293</b>
<b>Budget of Depreciation Fund</b>	<b>\$376,712</b>	<b>\$763,327</b>	<b>\$782,512</b>
<b>State Aid</b>	<b>\$49,797</b>	<b>\$51,679</b>	<b>\$615,620</b>
<b>Per Pupil Expenditures</b>	<b>\$20,103 (2020-21)</b>	<b>\$20,635 (2021-22)</b>	<b>\$21,340 (2022-23)</b>

Prepared By:

Quote #:

Date:

Prepared For:

Cust Phone #:

Cust Email:

Distributor:

TSR:

## 2024 Torchmate 4000 Series

The redesigned 2024 model Torchmate 4000 series has a strengthened structural steel box tubing frame with 4 box tube legs. This allows the machine to be supported with 4 legs, even on the largest 5'x10' 4510. This more rigid frame and leg structure allows for standard steel skirts around the machine with pegboard accessory hooks front and rear to hang consumables, personal protective equipment, and tools. The new box tubing machine frame has optional caster wheels to allow you to move the machine with one person to and from positions in your shop. Integrated box tube fork pockets also allow for easy unloading by forklifts. The machine also ships on the leveling feet directly so there is no de-palletization required when receiving the product. This reduces waste and decreases the time it takes to put your new 4000 series machine into service!

New accessory support featured in the machine frame allow users to customize optional shelving, can holders, work benches, and beverage openers. Universal pattern allows for many different configurations based on how your machine is located in your facility. Users can also create their own to mount on this pattern!

The newest machine in the line, the Torchmate 4505, is a machine that gives you a 5' x 5' plasma cutting table able to support a 5' x 5' sheet of steel, giving you over 55% more material capacity than a 4400. The largest machine in the line, the Torchmate 4510, is a machine that gives you the ability to process a 5' x 10' sheet of steel, giving you 36% more material capacity than a 4800. The 4505 and 4510 allow you to spend more time cutting and less time changing sheets. This allows you to cut larger single piece sheets to expand the capabilities of your shop for all types of jobs.



Finance your Investment starting at

# \$561

per month o.a.c.



Cutting Systems

Quote #:

Date:

Quote Valid for 30 Days

MACHINE	POWER SUPPLY	PRODUCT NUMBER	QTY	PRICE
	Flexcut 80 Amp, 3/4" Pierce			
	Flexcut 125 Amp, 1" Pierce			
<b>MACHINE TOTAL</b>				
ACCESSORIES, CONSUMABLES AND SOFTWARE OPTIONS	PRODUCT NUMBER	QTY	PRICE	
4000 TC Tube & Pipe Cutter				
Lincoln Electric PlateGuard™ Water Table Additive (5 Gallons)	TMS-310-0001-00			
Pneumatic Plate Marking Tool (Assembly required)	TMS-203-1000-24			
Flexcut Consumable Starter Kit				
Onboard VMD Nest, with DXF & DWG importer	TMS-106-0040-00			
TMCAD Additional License Dongle				
Two Stage Air filtration, moisture separation and dryer assembly	TMS-214-0000-00			
<b>Accessories Total</b>				
TRAINING OPTIONS	PRODUCT NUMBER	QTY	PRICE	
Torchmate Success Package				
TMCAD Project Book Classroom Series	TMS-106-0010-10			
Torchmate Academy, 4000 Series Online Learning Portal	TMS-010-0001-06			
4000 Series Virtual Training. One 2 hour block	TMS-010-0001-11			
Onsite Training, 2 Days	TMS-010-0003-02			
Advanced Onsite Training, 3 Days	TMS-010-0003-03			
Three Day Lincoln Electric Classroom Training. Reno NV, or Cleveland OH	TMS-010-0002-01			
<b>Training Total</b>				
<b>CUSTOMER CONTACT INFORMATION:</b>		<b>Subtotal</b>		
<b>CUSTOMER NAME</b>		<b>Shipping Total</b>		
<b>CONTACT NUMBER</b>		<b>Tax</b>		
<b>EMAIL</b>		<b>Grand Total</b>		
<b>SHIPPING ADDRESS</b>				
<b>REQUESTED SHIPPING DATE</b>				
FOB Reno to Hawaii Alaska International FOB S.F.	Mileage			
PO #	Date			
Card Holder	CW	<b>Grand Total</b>		
Billing Address				
Phone Number	I have been made aware of my Training Options, Plasma Cutter Power Requirements, Shipping/Unloading Requirements, Site Prep Guide and Terms and Conditions. <b>Customer Signature</b>			
Sales Associate				
TSR				
Distributor				
Distributor Contact				

This quote is valid for 30 days, and is governed by Seller's Terms and Conditions of Sale attached hereto and/or located at the website indicated below. Any reference to Buyer's request for quote incorporates only the technical information described therein. ALL TERMS AND CONDITIONS IN BUYER'S REQUEST FOR PROPOSAL/QUOTE ARE DEEMED MATERIAL ALTERATIONS AND ARE HEREBY EXPRESSLY REJECTED. Seller's Website: <https://torchmate.com/terms-and-conditions>

# CHOOSE YOUR CONFIGURATION | HALF SHEET MACHINES

## 4400 TABLE

The Torchmate 4400 is a powerful and fully assembled CNC Plasma cutting table. Designed to begin cutting immediately, this robust machine contains production grade components to deliver consistent cuts every time. This high-end cutting table has a small footprint and can easily fit into any small-to-medium sized fabrication shops. All that is required to begin cutting is compressed air, power, dedicated ground rod, and water. The water table fume extraction, slat supports, computer, CNC controller, height control, and magnetic torch breakaway are included in the base price.



## 4505 TABLE

The newest machine in the line, the Torchmate 4505, is a machine that gives you the ability to process a 5' x 5' sheet of steel, giving you over 55% more material capacity than a 4400.

# CHOOSE YOUR CONFIGURATION | FULL SHEET MACHINES



## 4800 TABLE

Designed for growing businesses, the Torchmate 4800 is the ideal cutting machine. Within minutes of uncrating, the fully assembled Torchmate 4800 machine will be ready for any job. With a longer cutting area, additional shearing fees and costs can be avoided. Lincoln Electric engineers have performed extensive tests to ensure that the table will consistently cut the same quality, regardless of where the material is positioned.

## 4510 TABLE

Like the other 4000 Series machines, the Torchmate 4510 is fully assembled and made to begin cutting in less than an hour after being delivered. This machine has the largest cutting area of all the 4000 Series tables. With a 5'x10' cutting area, the Torchmate 4510 has 36% more material capacity than the Torchmate 4800. This machine was designed to save you time and money while providing the same great benefits the Torchmate 4400, 4505 and 4800 offer.



## CHOOSE YOUR POWER SUPPLY



FLEXCUT® 80

### 80 Amp Plasma

**3/4" CUT CAPACITY (MILD STEEL)**

The FlexCut 80 is a constant current, plasma cutting power source that delivers faster cut speeds, optimal cut performance, and durability. The Flexcut 80 provides unparalleled plasma cutting efficiency.



FLEXCUT® 125

### 125 Amp Plasma

**1.0" CUT CAPACITY (MILD STEEL)**

The FlexCut 125 is the industry's first conventional air plasma cutter equipped with plasma marking. The powerful mechanized plasma cutter provides exceptional pierce and cut capabilities.

## CHOOSE YOUR ACCESSORIES



### 4000 TC PIPE & TUBE CUTTER

The two-axis tube cutter is capable of cutting and profiling schedule 40 pipe with an outside diameter of 1.5 to 6 inches and a machine cutting envelope of 84 inches. It easily connects to the 4x00 series tables with cable connections. The 2 inch through chuck offers motorized bevel cutting up to a 45° cut angle for weld coupons.

### TWO STAGE AIR FILTER ASSEMBLY

Extend the life of your consumables and protect your plasma cutter from harmful particulates and moisture from the compressed air source. This easy to install assembly filters particulates down to 5 microns, and dries the air with a moisture separator and desiccant drier stage.



### PLATEGUARD WATER TABLE ADDITIVE

Prevent surface corrosion on steel plate loaded on the table, and extend the life of your machine bed by adding Lincoln Electric's recommended concentrated Plateguard solution.



### PNEUMATIC PLATE MARKER

The Plate Marker Accessory is a pneumatic oscillating engraving tool that allows for high-precision markings and details on a wide range of metals.



# CHOOSE YOUR SOFTWARE



## Torchmate VMD/Nest with DXF & DWG Importer

Torchmate Visual Machine Designer (VMD) is the human-machine interface (HMI) to the Torchmate 4000 Series CNC Machines. VMD automatically programs cut parameters for the most common materials into the G-Code file, such as Feedrate, Pierce Height, and Cut Height. VMDnest provides the machine operator with onboard single-sheet nesting capabilities. Bring multiple DXF or DWG' s directly to the machine from your CAD software and have the operator nest them to a sheet, no offline software required.

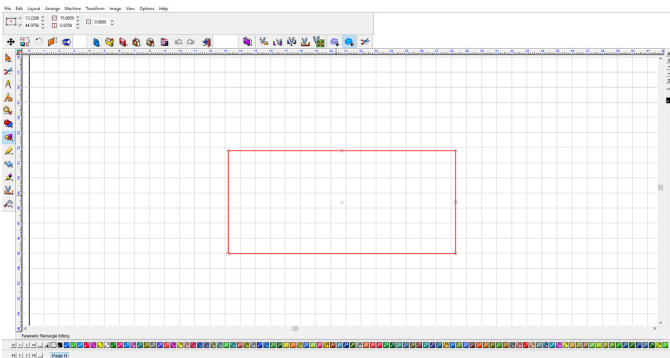

## Torchmate CAD Lite

Torchmate CAD offers online licensing options along with versatile drawing features including shape creating, importation of other file types such as DXF, tracing of scanned images, and text design. The user-friendly interface allows both new and experienced users to design any part imaginable from simple tabs and brackets to intricate signs and art scenes. Torchmate CAM compensates for the cut width (kerf) of the plasma arc to ensure that a part is cut as accurately as it was drawn. Torchmate CAD/CAM software is supported by Torchmate with a selection of digital training options.

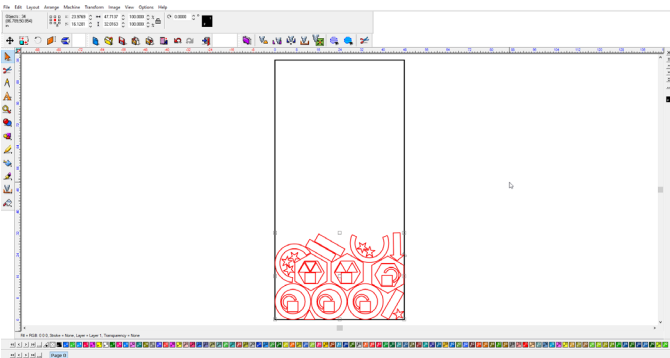

## Torchmate CAD Full

Includes Offline Nesting, raster to vector feature, a vectorization tool and Advanced Shape Library. Offline Nesting minimizes the amount of scrap material produced during cutting using an efficient algorithm to place many components tightly together leaving minimal material waste. The raster to vector feature converts images to black and white and automatically traces edges or manually trace using the node editing tool. The vectorization tool allows you to convert image files into editable CAD drawings. The off-line shape library give you 89 predesigned common shapes that can be edited to fit your needs.

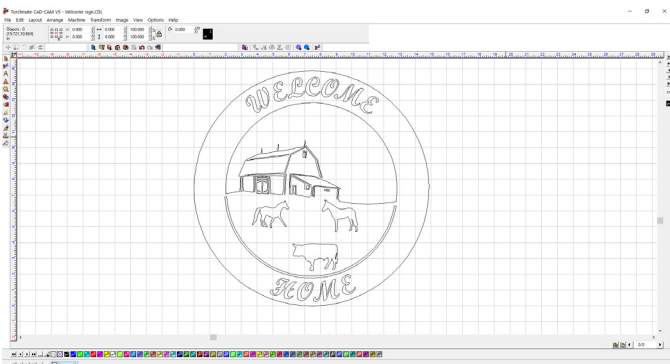

## Torchmate CAD Professional Text Compose Module

This upgrade gives you over 2,000 fonts to choose from and allows them to accurately fit the text to an arc or any other shape in the cutting area automatically. There are hundreds of silhouette images that are suitable for plasma cutting. These are time-saving upgrades that can be worth while for businesses that heavily use the text tool. (TM CAD/CAM Design & upgrade required)

# CHOOSE YOUR TRAINING PACKAGE

## Torchmate 4000 Series Success Packages

PLATINUM	GOLD	SILVER	BRONZE
<ul style="list-style-type: none"> <li>• Torchmate Academy 4 users - 1 year access</li> </ul>	<ul style="list-style-type: none"> <li>• Torchmate Academy 3 users - 1 year access</li> </ul>	<ul style="list-style-type: none"> <li>• Torchmate Academy 2 users - 1 year access</li> </ul>	<ul style="list-style-type: none"> <li>• Torchmate Academy 1 user - 1 year access</li> </ul>
<ul style="list-style-type: none"> <li>• Torchmate Onsite 2 days of training</li> </ul>	<ul style="list-style-type: none"> <li>• Torchmate classroom 1 seat</li> </ul>	<ul style="list-style-type: none"> <li>• Torchmate LIVE 2 hour private class</li> </ul>	<ul style="list-style-type: none"> <li>• TMA completion within 30 days = \$500 account credit</li> </ul>
<ul style="list-style-type: none"> <li>• \$1,200 FlexCut consumables package</li> </ul>	<ul style="list-style-type: none"> <li>• \$1,200 FlexCut consumables package</li> </ul>	<ul style="list-style-type: none"> <li>• \$600 FlexCut consumables package</li> </ul>	<ul style="list-style-type: none"> <li>• \$600 FlexCut consumables package</li> </ul>
<ul style="list-style-type: none"> <li>• TMA completion within 30 days = \$500 account credit</li> </ul>	<ul style="list-style-type: none"> <li>• TMA completion within 30 days = \$500 account credit</li> </ul>	<ul style="list-style-type: none"> <li>• TMA completion within 30 days = \$500 account credit</li> </ul>	

\*Travel and lodging not included

## TRAINING OPTIONS

### ONLINE

#### Torchmate Academy Machine and CAD Training

Torchmate Academy is an online-based learning platform that takes the user guide's information to a new level. It covers all of the key features and functions in more detail.

Video walkthroughs and supporting documentation are provided throughout to assist you in getting the most out of your Torchmate investment.

<https://torchmate.com/academy>

### CLASSROOM

#### Torchmate Classroom Machine and CAD Training

Classroom training is a 2-3-day, hands-on project-based classroom training held at locations across the U.S. Learn and create real-world projects that cover the TMCAD software and its features. Take those projects and cut them out on the machine where the trainers will cover everything from cut quality to proper maintenance. Build the proper foundation to streamline your success.

[www.torchmate.com/seminars](http://www.torchmate.com/seminars)

### VIRTUAL

#### Torchmate LIVE - Machine and CAD Training

Torchmate LIVE is an interactive training solution for individuals that cannot travel or have the time for in-house training, but need personal interaction of an on-site training. We bring the instructor to your facility via the internet. Join via ZOOM with our expert trainers to cover the machine basics and operations.

Schedule your time on our website:

[www.torchmate.com/seminars](http://www.torchmate.com/seminars)

### ONSITE

#### Torchmate Onsite - Machine and CAD Training

Have our expert technicians come to your facility for 1-, 2-, or 3-day machine training and servicing at your facility. The provider will cover the machine operations, proper maintenance, and software training for a flat rate.

To get a updated cost and scheduling availability, email our team:

[LECSfieldservice@lincolnelectric.com](mailto:LECSfieldservice@lincolnelectric.com)

# CHOOSE YOUR ACCESSORY PACKAGE



## APPLICATION INFORMATION

Lincoln Electric offers multiple personal protective equipment and post process tooling kits to complete any CNC Plasma Cutting machine. The basic kit provides all of the recommended PPE for a safe user experience when Plasma Arc cutting. An advanced kit offers all of the recommended PPE in addition to post process tooling and consumables for Plasma Arc cutting and material finishing.

## ADVANCED CUTTING SAFETY KIT PRODUCT HIGHLIGHTS

- Provides everything needed to safely operate your CNC Plasma Cutting machine in a convenient Lincoln Electric duffel bag
- Heavy duty Lincoln Electric welding gloves for handling material before and after cutting
- Four, clear Lincoln Electric safety glasses for general around the shop use
- Shade 5 Lincoln Electric safety glasses and full face shield for safe monitoring of the plasma arc during cutting
- Extendable magnetic retrieval tool to retrieve small cut parts safely from the outside of the machine
- Multi-Purpose scraping tool to remove light dross from the plasma cut edges
- 4 1/2" Angle Grinder for wire wheel and flap disc consumables
- Two, 5/8-11 Arbor wire wheel cups for dross removal on plasma cut edges
- Ten, 80 grit ceramic flap discs for preparing plasma cut edges with a semi-fine finish for welding
- Lincoln Electric Leather Welding Apron to contain and protect the users clothing from grinding debris or weld spatter
- Clear Lincoln Electric full face shield for excellent visibility for all grinding applications

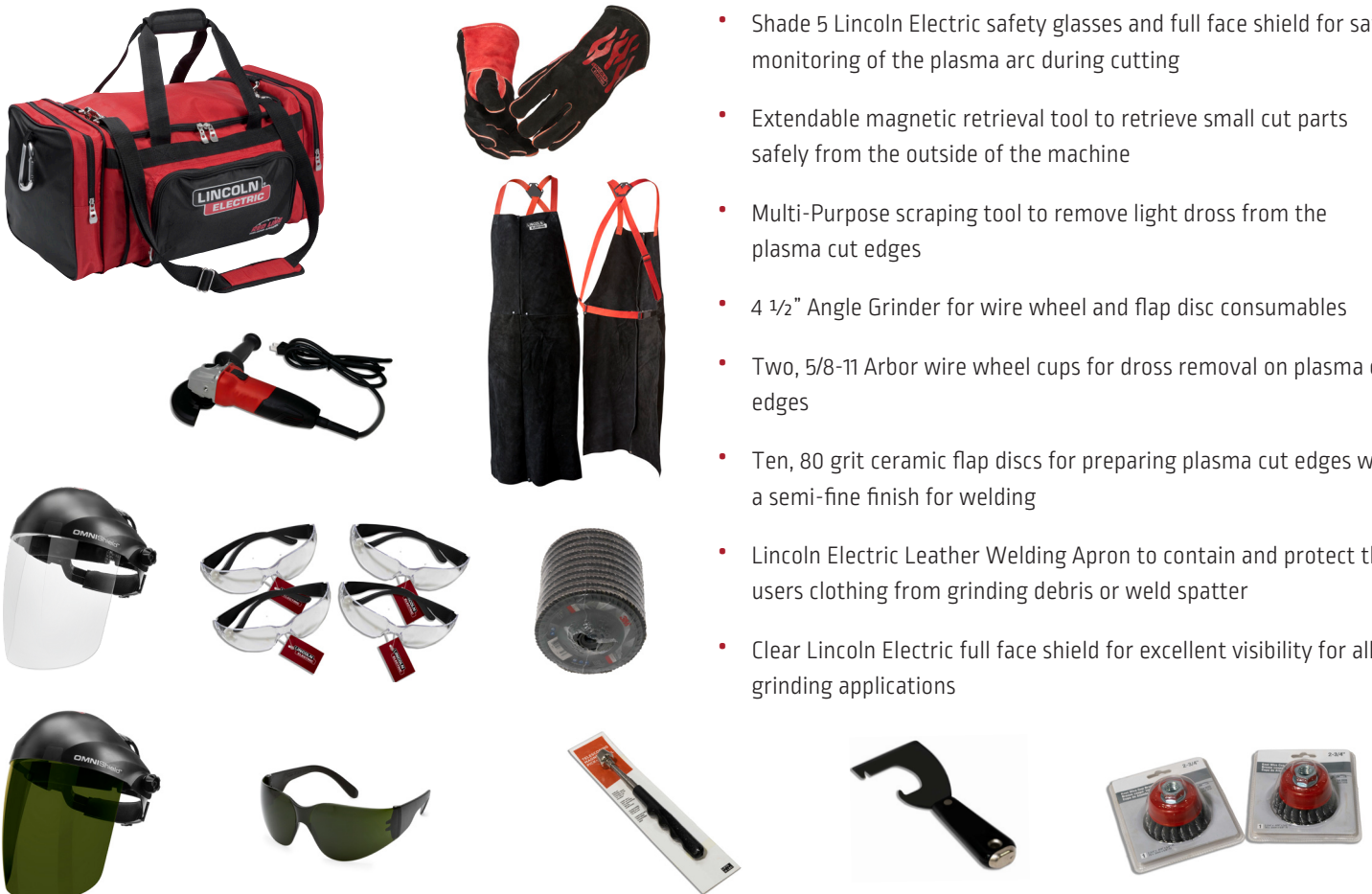

# 3 DAY IN-HOUSE TORCHMATE TRAINING

## Torchmate In-House

In-house training is a 3-day, hands-on project-based classroom training held in Reno & Cleveland. Learn and create real-world projects that cover the TMCAD software and its features. Take those projects and cut them out on the machine where the trainers will cover everything from cut quality to proper maintenance. Build the proper foundation to streamline your success.



## 3 Day Basic Torchmate Operations Training

- Introduce the CAD software
- Go over basic functions and tools
- Generate basic shapes
- Discuss WELDING and MAKE/BREAK PATH functions
- Generate NAMEPLATE project
- Generate CLIP ART project
- Import images from web and use VECTORIZATION tool
- Node Editing
- Polyarc vs. Polygon
- Generate precision part by node editing
- Discuss multi speed files and their creation
- Array, Nesting, and Badging



[www.torchmate.com/seminars](http://www.torchmate.com/seminars)



# SYSTEM INCLUDES

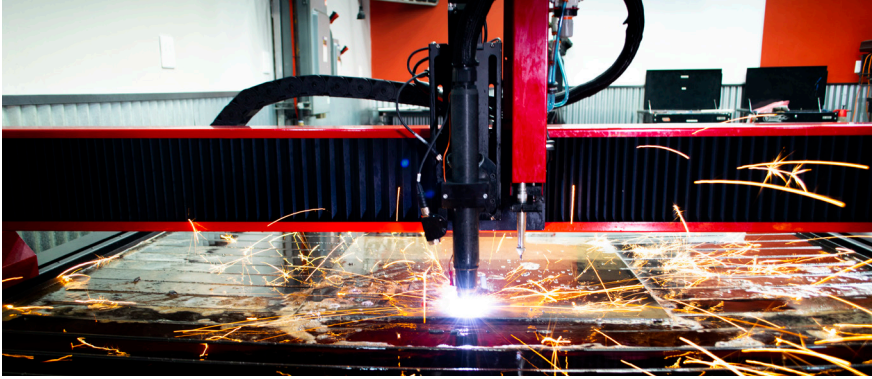

- Complete half sheet and full sheet Multiple Station Cutting Area CNC Plasma Tables
- Ohmic Initial Height Sense with Automatic Torch Arc-Voltage Height Control
- Laser Pointer Attachment
- Magnetic Torch Breakaway
- Water table fume extraction
- CNC Controller
- Optional CAD Software
- Optional DXF & DWG Importer (use with most CAD programs)
- Industrial Touchscreen HMI
- Consumable Starter Kit
- Technical Phone Support
- 2 Year Complete System Warranty

## TABLE SPECIFICATIONS

### Power Requirements

- 110V / 10A Dedicated circuit
- 87-109 psi [ 6-7.5 bar ] 380 SCFH 180 SLPM
- FC80 1 phase: 208,230 50/60hz or 3 phase 208,230,400,460,575 50/60hz
- FC125 3 phase: 380,400,415,460,575 50/60hz

### Machine Size

- 4400 74" x 67" x 63"
- 4800 74" x 114" x 63"
- 4505 86" x 79" x 63"
- 4510 86" x 138" x 63"

### Shipping Weight

- 4400 1,322 lbs [600 kg]
- 4800 1,847 lbs [838 kg]
- 4505 1,480 lbs [671 kg]
- 4510 2,452 lbs [1,112 kg]

See OSHA guidelines for proper forklift

### Water Capacity

- 4400 60 Gallons [ 230 Liters ]
- 4505 71 Gallons [ 269 Liters ]
- 4800 107 Gallons [ 405 Liters ]
- 4510 140 Gallons [ 530 Liters ]

### Cut Speed

- Flexcut 80 1/4" [ 148 ipm ], 1/2" [ 52 ipm ], 3/4" [ 26 ipm ]
- Flexcut 125 1/4" [ 210 ipm ], 1/2" [ 88 ipm ], 3/4" [ 52 ipm ], 1" [ 32 ipm ]

### Plasma Pierce Capacity

- Flexcut 80 3/4" Mild Steel
- Flexcut 125 1" Mild Steel

### Traverse Speed

- 500 ipm

### Material Weight Capacity

- 4400 at 48" x 48" holds maximum of 652.8 lbs [40.8 lbs per square foot]
- 4800 at 48" x 96" holds maximum of 1,305.6 lbs [40.8 lbs per square foot]
- 4505 at 60" x 60" holds maximum of 1,020 lbs [40.8 lbs per square foot]
- 4510 at 60" x 120" holds maximum of 2,040 lbs [40.8 lbs per square foot]

### Motors

- Stepper Motors [ 3 ] 396 oz-in

### Drive System

- Spring loaded Rack and Pinion

### Linear Guidance

- Dual 20 mm Y axis and Dual 15mm X axis

### Height Control

- Magnetic Breakaway
- Ohmic Sensing
- Automatic Torch Arc Voltage Height Control

### Software

- Easy-To-Use Lincoln Electric VMD User Interface
- Optional onboard DXF CAM Importer with Irregular Part Nesting
- Onboard Popular Shape Library
- Optional offline Torchmate Cad/Cam Software

### Safety

- Safety System Supporting Emergency Stop Switch
- Safety System Extended To External Peripherals
- External Drive Power On Switch

### Machine Construction

- Structural Steel Welded Frame Members with Powder Coated Finish

### Warranty

- 2 Year Machine and Plasma Torch Lead Warranty
- 3 Year Plasma Power Supply Warranty

# PLASMA SPECIFICATIONS



**FLEXCUT® 80**



**FLEXCUT® 125**

Product Name	Input Power Voltage/Phase/Hz	Rated Input Current/Voltage/Duty Cycle	Air Pressure Required	Production Cutting Capacity	
<b>FlexCut 80</b>	208/230/400/460/575 3PH 50/60Hz	60A/140V /100% 80A/140V /80%	87-109 PSI (6.0 - 7.5 Bar)	Mild Steel	3/4" (20 mm)
	230 1PH 50/60Hz	60A/140V /100% 80A/140V /80%		Stainless	5/8" (16 mm)
	200-208 1PH 50/60Hz	60A/140V /100% 80A/140V /80%		Aluminum	5/8" (16 mm)
<b>FlexCut 125</b>	308-400-415/460/575V 3PH 50/60Hz	125 A/125V /100%	90-120 PSI (6.2 - 8.2 Bar)	Mild Steel	1.0" (25mm)
				Stainless	3/4" (20 mm)
				Aluminum	1.0" (25 mm)

\*Cut speeds for best quality, production results may vary.

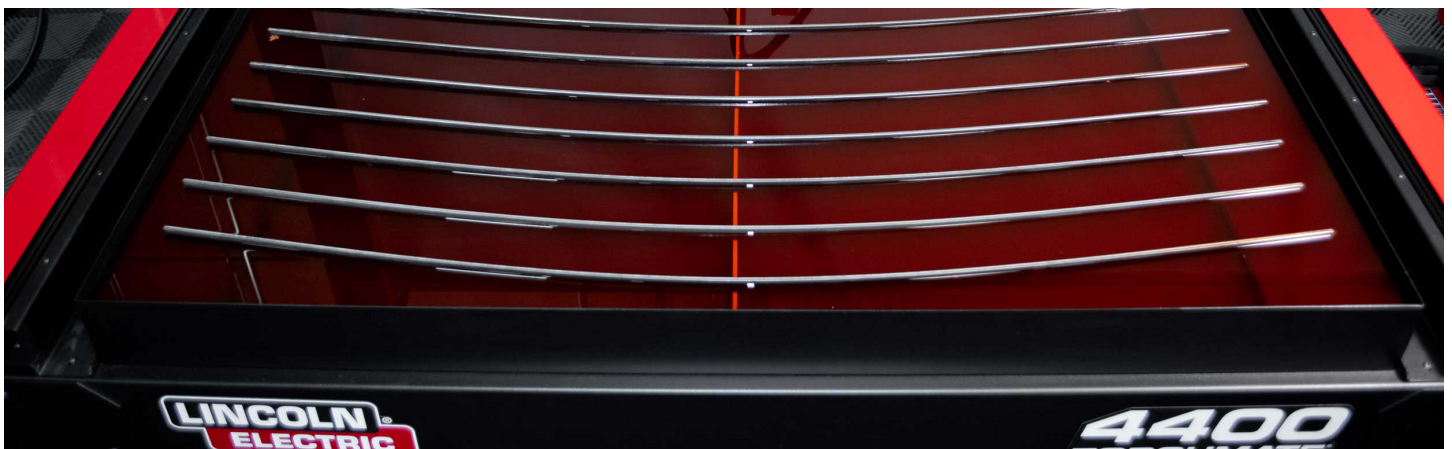

# LOCATION

When installing a Lincoln Electric CNC System in your shop, there are many factors that will influence the potential productivity, ease of use of the machine, and the safety of the operator. The main factors to prepare for include the physical layout and placement of the machine in the shop, the availability of power, an EMI ground, compressed air and other gases, and ventilation.

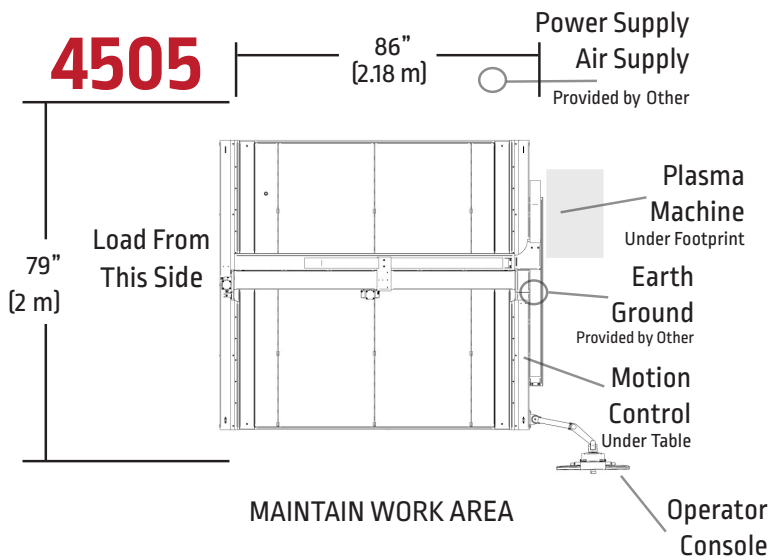
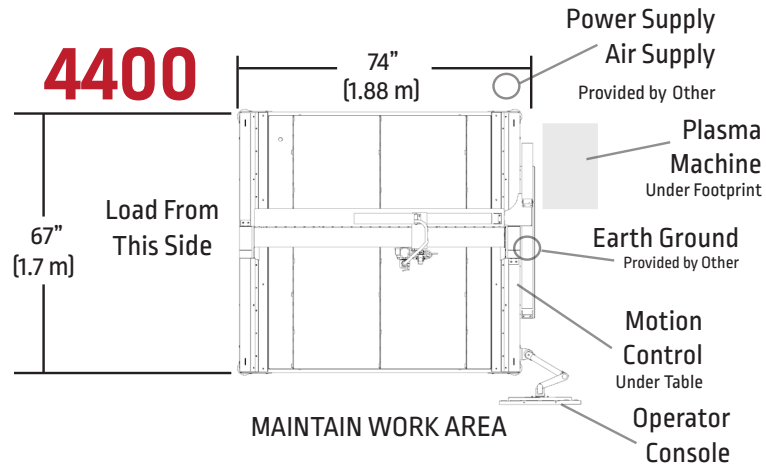

**Please Note:** Power supply does not include a plug, must be supplied by an electrician.

Proper grounding must be provided to ensure personnel safety and to suppress high frequency noise. The foundation of good grounding is an effective earth ground rod. A star ground point connects to the rod with a short, heavy conductor. A simple copper clad steel rod can be driven into the ground to create a grounding rod.

**Please Note:**

- When preparing to install the Lincoln Electric CNC Cutting System, provide sufficient space. Three feet of work space (914 mm) should be obstacle free around the machine.
- Forklift load material opposite the cable carrier only. Utilize the back of the machine to park the gantry while loading material.
- A dedicated earth ground must be provided and should be installed in a manner to reduce trip hazard.
- The power lead included is limited to 10 feet.

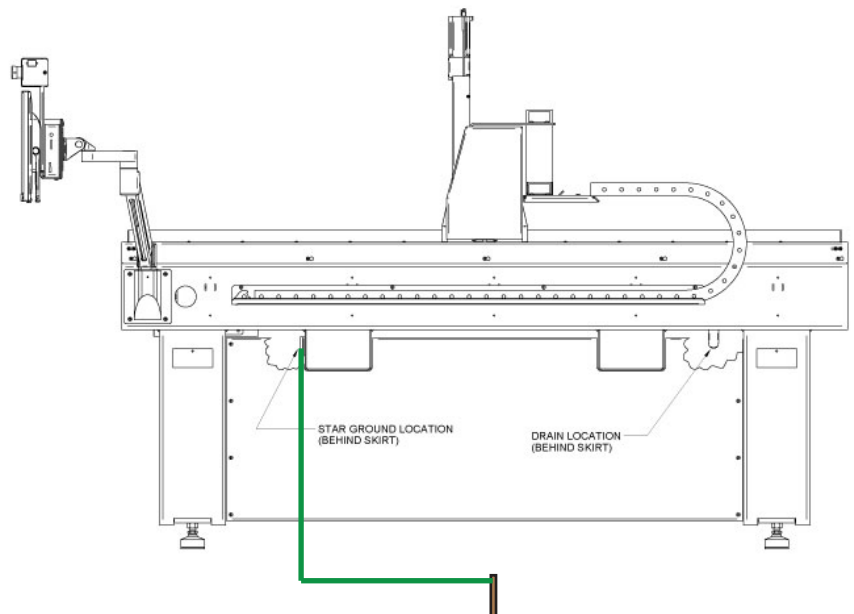

# LOCATION

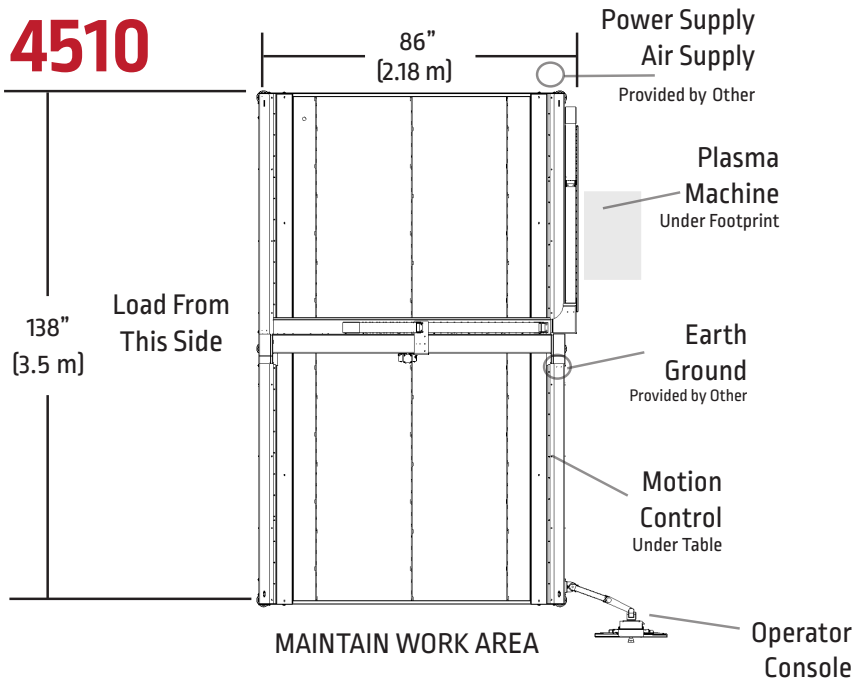
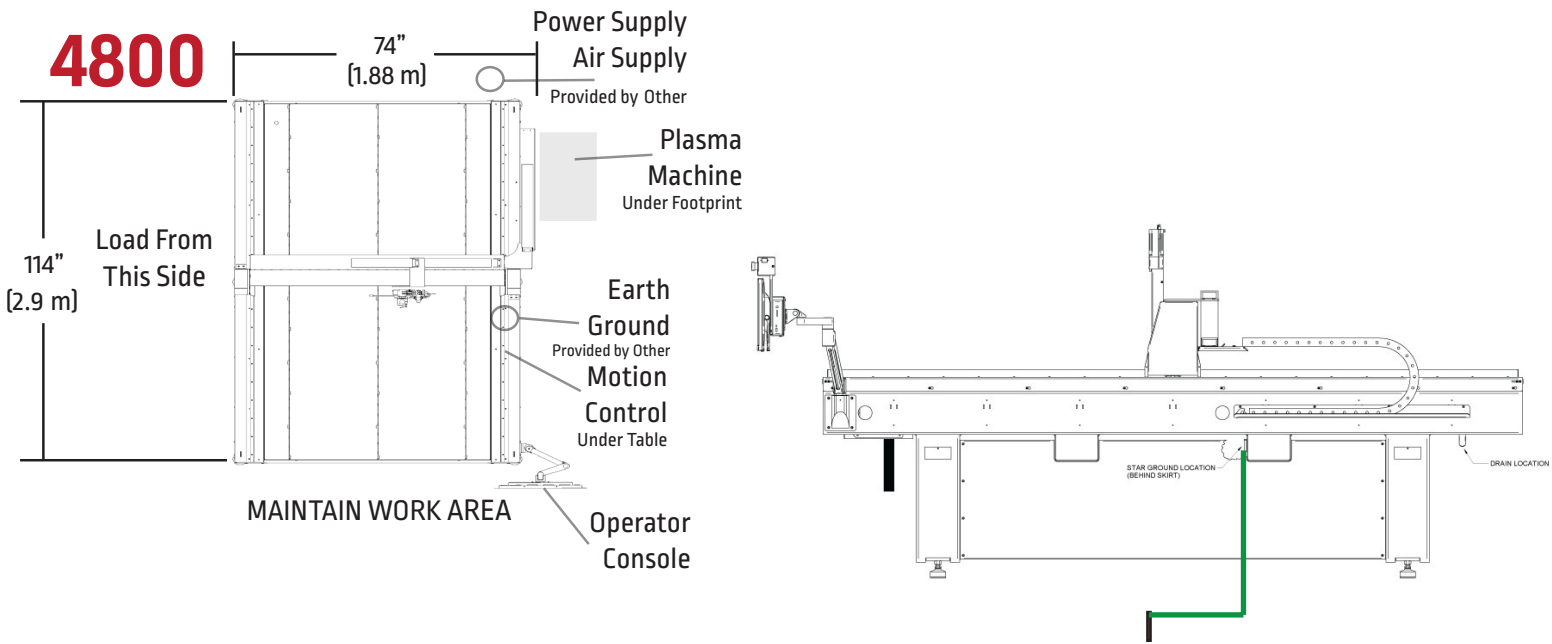

**Please Note:** Power supply does not include a plug, must be supplied by an electrician.

Proper grounding must be provided to ensure personnel safety and to suppress high frequency noise. The foundation of good grounding is an effective earth ground rod. A star ground point connects to the rod with a short, heavy conductor. A simple copper clad steel rod can be driven into the ground to create a grounding rod.

# MAINTAIN YOUR WORK AREA

- When preparing to install the Lincoln Electric CNC Cutting System, provide sufficient space. Three feet of work space should be maintained at front of machine
- Overhead Crane or forklift to load material opposite the cable carrier only. Utilize the back of the machine to park the gantry while loading material.
- A dedicated earth ground must be provided and should be installed in a manner to reduce trip hazard
- The table power leads included is limited to 10 feet.

# CUSTOMER TESTIMONIALS & SUCCESS STORIES

## Pin Up Metal Garage by Cynthia Gauthier

Pin Metal Up is a custom metal fabrication shop located in Quebec, Canada and owned by professional Monster Truck driver, Cynthia Gauthier. She uses the Torchmate 4400 to make custom signs, fire pits, parts for vehicles & more.



Full story & video [\[link\]](#)

## Gator Pit BBQ

Gator Pit is a company that designs, constructs and sells custom-made barbecue pits, backyard grills and smokers, tailgating grills and smokers and trailer mounted pits using a Torchmate 4510.



Full story & video [\[link\]](#)

## Thomas Precision Welding

TP Welding is a multifaceted metal fabrication and welding business. It is a father and son owned business that has been rapidly expanding. They now have a Torchmate 4510 and a Cooper Cobot.

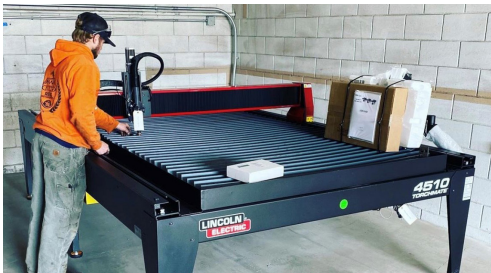

Full story & video [\[link\]](#)

## May-Day Metal Worx

May-Day Metal Worx is an American made, veteran owned and operated metal fabrication business. They specialize in fabricating custom metal art, signs, ornamental decor and fire pits and much more.



Full story & video [\[link\]](#)

## Rockstar Garage

Rockstar Garage is the first lifestyle garage of its kind. It is known for the manufacturer builds it turns out to promote new parts, supporting branding initiatives and activation at events.



Full story & video [\[link\]](#)

## Tri Fusion LLC

"I saw what the Torchmate was capable of and had grand ideas about how I could cut anything I wanted out of metal," John said. Without much of a plan, that is how Tri Fusion LLC was born.



Full story & video [\[link\]](#)

Learn more about our training options at [www.torchmate.com/academy](http://www.torchmate.com/academy)



To purchase consumables, please visit [www.torchmatestore.com](http://www.torchmatestore.com)



The Lincoln Electric Company is manufacturing and selling high quality welding equipment, consumables, and cutting equipment. Our challenge is to meet the needs of our customers and to exceed their expectations. On occasion, purchasers may ask Lincoln Electric for information or advice about their use of our products. Our employees respond to inquiries to the best of their ability based on information provided to them by the customers and the knowledge they may have concerning the application. Our employees, however, are not in a position to verify the information provided or to evaluate the engineering requirements for the particular weldment. Accordingly, Lincoln Electric does not warrant or guarantee or assume any liability with respect to such information or advice. Moreover, the provision of such information or advice does not create, expand, or alter any warranty on our products. Any express or implied warranty that might arise from the information or advice, including any implied warranty of merchantability or any warranty of fitness for any customers' particular purpose is specifically disclaimed. Lincoln Electric is a responsive manufacturer, but the selection and use of specific products sold by Lincoln Electric is solely within the control of, and remains the sole responsibility of the customer. Many variables beyond the control of Lincoln Electric affect the results obtained in applying these types of fabrication methods and service requirements. Subject to Change – This information is accurate to the best of our knowledge at the time of printing. Please refer to [www.lincolnelectric.com](http://www.lincolnelectric.com) for any updated information.

 **Warning:** Cancer and Reproductive Harm - <https://www.p65warnings.ca.gov/>



Quote

Border States - SBF
1020 4th Ave
Scottsbluff NE 69361-3611
Phone: 308-632-7127

Quote: 27333881
Sold-To Acct #: 211624
Valid From: 12/22/2023 To: 12/29/2023
PO No: LOCKER ROOMS AND GYM
Payment Terms: Net 25th prox

Created By: Sean Hinze
Tel No: 308-225-7049
Fax No:

KIMBALL SCHOOLS
901 S NADINE ST
KIMBALL NE 69145-1632

Inco Terms:
FOB ORIGIN

Ship-to:
KIMBALL SCHOOLS
901 S NADINE ST
KIMBALL NE 69145-1632

Table with columns: Cust Item, Item, Material MFG - Description, Quantity, Price Per, UoM, Value. Includes line items 000010 and 000020, and a summary section for taxes and net amount.

To access Border States Terms and Conditions of Sale, please go to
https://www.borderstates.com

The quoted sales tax is an estimate only based upon the information
provided in this quote and will be finalized at the time of Invoice
based upon the material purchased, quantity purchased, and delivery
location.

Shipping and handling fees in this quote are an estimate only and will
be finalized at the time of Invoice.

All clerical errors contained herein are subject to correction. In the event of any cost or price increases from
manufacturers or other suppliers, caused by, but not limited to, currency fluctuations, raw material or labor
prices, fuel or transportation cost increases, and any import tariffs, taxes, fees, or surcharges, Border States
reserves the exclusive right to change its pricing at the time of shipping and will provide notice of any such
change to its customers prior to costs being incurred.



Alan R. Strauch  
Licensed-Bonded-Insured  
1465 Bonanza  
Gering, NE 69341  
[strauchelec@yahoo.com](mailto:strauchelec@yahoo.com)  
308-765-0575

We hereby submit specifications and estimates for; **Kimball Public Schools 901 S Nadine St. Kimball, NE 69145**

**Scope of Work:** Per your request and a comprehensive walkthrough and comprehension of blue prints we have comprised a complete list of objectives needed to complete the modifications. Included in this proposal, all labor, material and equipment needed to complete the following: LED light replacement

- **Removal of 84 old lighting fixtures in locker rooms, installation of 46 new lights.**

Exclusions- Any extras not discussed during walk thru, nor any light fixtures, nor any disposal of old fixtures, nor any unforeseen obstacles.

**TOTAL PROJECT INVESTMENT: \$ 14,350.00**

**PAYMENT INFORMATION:** 50% down before material can be ordered and work to start. Unless otherwise documented. Thereafter payments made on percentage of completion monthly or at completion.

STRAUCH ELECTRIC, LLC:

  
Alan R. Strauch

NOTE: This proposal may be withdrawn by Strauch Electric, LLC if not accepted within 30 days.

**Acceptance of Proposal:** The above prices, specifications and conditions are satisfactory and are hereby accepted. You are authorized to do the work specified. Payment will be made as outlined above.

Date of Acceptance: \_\_\_\_\_  
Signature: \_\_\_\_\_



Alan R. Strauch  
Licensed-Bonded-Insured  
1465 Bonanza  
Gering, NE 69341  
[strauchelec@yahoo.com](mailto:strauchelec@yahoo.com)  
308-765-0575

We hereby submit specifications and estimates for; **Kimball Public Schools 901 S Nadine St. Kimball, NE 69145**

**Scope of Work:** Per your request and a comprehensive walkthrough and comprehension of blue prints we have comprised a complete list of objectives needed to complete the modifications. Included in this proposal, all labor, material and equipment needed to complete the following: LED light replacement

- **Removal of 36 old lighting fixtures in South Gym, installation of 36 new lights. New lights will be put on dimmers.**

Exclusions- Any extras not discussed during walk thru, nor any light fixtures, nor any disposal of old fixtures, nor any unforeseen obstacles.

TOTAL PROJECT INVESTMENT: \$ 12,400.00

PAYMENT INFORMATION: 50% down before material can be ordered and work to start. Unless otherwise documented. Thereafter payments made on percentage of completion monthly or at completion.

STRAUCH ELECTRIC, LLC:

  
Alan R. Strauch

1/2/24

NOTE: This proposal may be withdrawn by Strauch Electric, LLC if not accepted within 30 days.

Acceptance of Proposal: The above prices, specifications and conditions are satisfactory and are hereby accepted. You are authorized to do the work specified. Payment will be made as outlined above.

Date of Acceptance: \_\_\_\_\_

Signature: \_\_\_\_\_

# INVOICE

## McNally Asphalt Paving

Quality Don't Cost, It Pays!

**1-855-PAV ROAD**

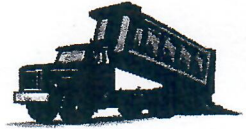
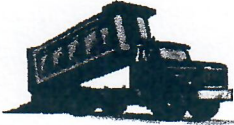

PROPOSAL SUBMITTED TO Kimball Public Schools PHONE \_\_\_\_\_  
 ADDRESS 901 s Nadine street JOB LOCATION Private property  
 CITY Kimball STATE Ne ZIP \_\_\_\_\_

We hereby submit specifications and estimates for:

- |  |   |
|--|---|
| <input type="checkbox"/> Paving              | <input type="checkbox"/> Grading        |
| <input checked="" type="checkbox"/> Driveway | <input type="checkbox"/> Grass Killer   |
| <input type="checkbox"/> Parking Lot         | <input type="checkbox"/> Sawcut Removal |
| <input type="checkbox"/> Petromat            | <input type="checkbox"/> Road Base      |
| <input type="checkbox"/> Tackcoat            | <input type="checkbox"/> Other          |

West parking lot

Area #1 \_\_\_\_\_ x \_\_\_\_\_ = \_\_\_\_\_  
 Area #1 \_\_\_\_\_ x \_\_\_\_\_ = \_\_\_\_\_  
 Area #1 \_\_\_\_\_ x \_\_\_\_\_ = \_\_\_\_\_  
 Area #1 \_\_\_\_\_ x \_\_\_\_\_ = \_\_\_\_\_  
 Area #1 \_\_\_\_\_ x \_\_\_\_\_ = \_\_\_\_\_

To mill out 2 inches clean prep and  
 Prime then install 2 inches of  
 Commercial grade hot mix asphalt

Total Sq. Ft. Approx 44,560  
 Price per Sq. Ft. Flat rate price  
 Total \$167,00.00

Traffic marking and striping is included  
 All labor and material included

XXXXXXXXXX

Make Checks Payable to Owner

We Propose hereby to furnish material and labor - complete in accordance with above specifications, for the sum of:

\_\_\_\_\_ Dollars (\$ \_\_\_\_\_)  
 Payment to be made as follows: \_\_\_\_\_ Tax (% \_\_\_\_\_)  
Paid in full upon completion Total (\$ 167,000.00)

All material is guaranteed to be as specified. All work to be completed in a workman-like manner according to standard practices. Any alterations or deviation from above specifications involving extra costs will be executed only upon written orders, and will become an extra charge over and above the estimate. All agreements contingent upon strikes, accidents or delays beyond our control. The owner is responsible for carrying fire, tornado and any other necessary insurance. Our workers are fully covered by Workmen's Compensation Insurance.

**Acceptance of Proposal** - The above prices, specifications and conditions are satisfactory and are hereby accepted. You are authorized to do work as specified. Payment will be made as outlined above.

Authorized Signature Martin McNally Date 3-30-23

Customer Signature \_\_\_\_\_ Date of Acceptance \_\_\_\_\_

# RECOMMENDATIONS

1

Option 1: Cradle to Grave

Order 1570 PVC ceiling tiles

**Price Tag:**

Amazon - \$143 for 10 pieces =  $\$14.3 \times 1570 = \$22.5K$

New Price Tag -  $\$22.5K - \$143 = \$22,357$

Menards:  ~~$\$17ea \times 1570 = \$27K$~~

Home Depot:  ~~$\$157 for 8 pieces = \$19.6 \times 1570 = \$31K$~~

BSE: Not Available



# QUOTATION

106 Max Hurt Drive  
Murray KY 42071

Toll-Free: 1-800-323-7745  
[varsityscoreboards.com](https://varsityscoreboards.com)

## BILL TO:

**Darrell Howitt**  
dhowitt@kpslonghorns.org  
(308)539-5880  
**Kimball Public Schools - NE**  
901 S Nadine St Kimball, NE 69145

## SHIP TO:

## DETAILS

**Quote Number:** 107992735  
**Prepared By:** Tassie Gossum  
**PO Number:**  
**Created On:** November 8, 2023

PART #	DESCRIPTION	QTY.	LIST PRICE (\$)	EXTENDED PRICE (\$)
	<b>28' x 8' FOOTBALL SCOREBOARD</b> <ul style="list-style-type: none"> <li>32", 26", and 20" LED digits with Protective Shields</li> <li>Home/Guest Score, To Go, and Ball On up to 99</li> <li>Clock counts down from 99:59.59</li> <li>Galvanized steel cabinet with powder coat finish</li> <li>Outdoor Horn</li> <li>Wireless remote control with internal rechargeable battery and high gain antenna</li> <li>5 - Year Limited Warranty</li> </ul>	1	\$14,295.00	\$14,295.00
SPT28-OD	TRUSS 28' ARCH	1	\$5,095.00	\$5,095.00
SP28X31-OD	28' School Identification / Sponsor Panel for Outdoor Scoreboards	1	\$1,375.00	\$1,375.00

**Subtotal: \$20,765.00**

**SHIPPING AND HANDLING: \$1,695.00**

**Quote Total: \$22,460.00**

**NOTES**

**OPTIONS: CONTROLLER CARRY CASE \$150**

*Quote valid for 30 days. Installation and electrical work not included. Visa, Mastercard, American Express, personal checks, and ACH Check Forms accepted for your convenience.*



Scroll down to see your product

Please review these graphics carefully. Changes requested after acceptance of this quote may result in additional charges. Colors are for proofing only and may vary on different printers, monitors, and finished products.

Model - 7528-22





SPONSOR AREA

29.5" X 28'

Model - 7528-22

28 ft

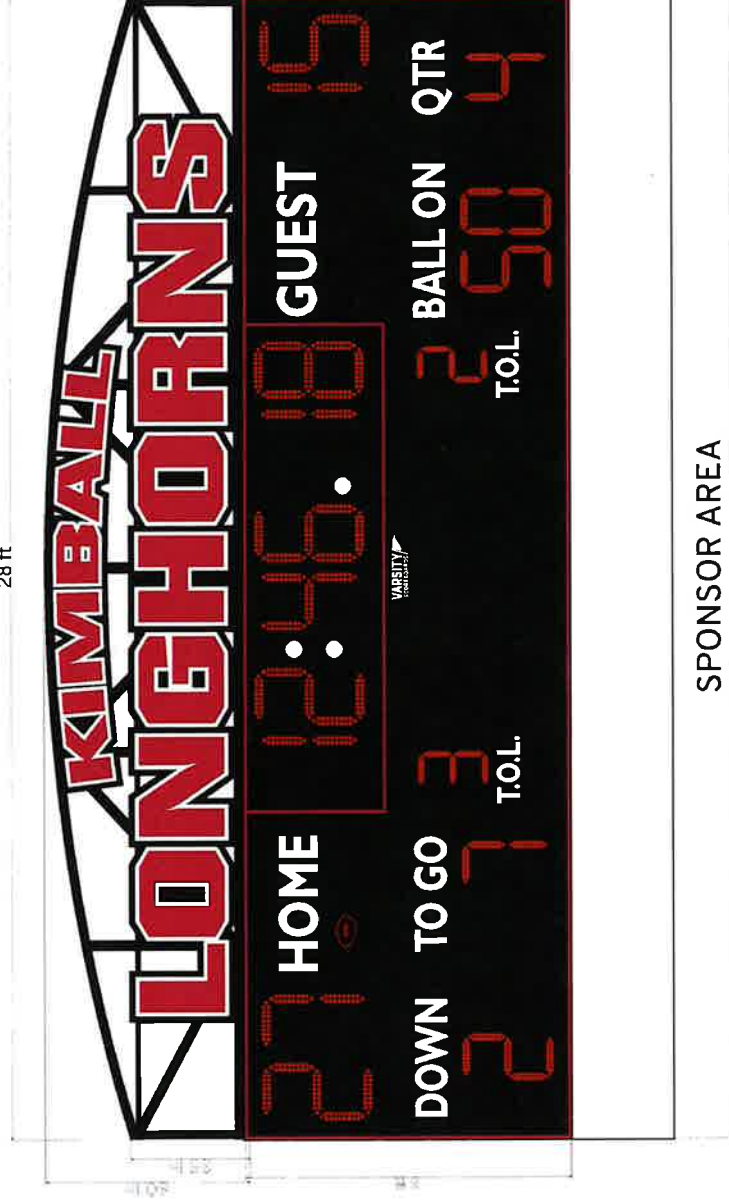

SPONSOR AREA

29.5" X 28'

Logo creation fee may apply. If you have any questions concerning this quotation or if there is anything else I can do for you, please give me a call. Thank you for the opportunity to quote on your project.

Sincerely,

**TASSIE GOSSUM, Sales Associate**

[tassie.gossum@varsityscoreboards.com](mailto:tassie.gossum@varsityscoreboards.com)

TEL: 800.323.7745x127



Insurance

The Board of Education shall provide ample and broad liability and casualty insurance coverage for its members, employees, and the facilities and property owned by the district.

Insurance coverage may be purchased through local agents or affiliates with the Nebraska School Boards Association.

The district's insurance coverage shall be annually reviewed to ascertain if the limits of liability and the amount of casualty coverage are deemed ample for the district. In addition, premium comparisons should periodically be made to determine if the district is getting the best value for the premium dollars expended.

Adopted: December 13, 1999

Revised: January 11, 2016

Fund Raisers

Schools and organizations within schools that wish to do fund raising activities shall be allowed to do so only after receiving expressed approval from the Activities Director and/or the building principal. The Activities Director/building principal in making a determination as to approve the fund raising activity shall consider the following:

1. What is the purpose for raising the funds
2. Could the funds legitimately be provided through the district's General Fund budget of expenditures
3. What, if any, will be the effect upon the local business community and parents if the fund raising project is approved
4. What other considerations/benefits can be derived from such a fund raising activity

Adopted: February 14, 2000

Revised: January 11, 2016

Advertising and Promotions in the School and by Students

Advertising and the promotion of the pecuniary interests of any private business or for-profit organization shall generally be prohibited, within the schools and by the students of the Kimball Public Schools. Students shall not be allowed to carry home any fliers or communications, or the advertising shall not be posted within buildings that promotes events, sales, etc. for any for-profit business or organization, except as follows:

1. Educational material that may be of benefit to students/parents
2. Samples, calendars, supply catalogs, etc., which may be distributed to staff for study, purchasing or routine classroom use, with administrative approval
3. Information related to the approved fund raising activities being conducted within the school or by any of its organizations and for the school picture taking program

Upon the expressed approval of the building principal, information, promotional, and registration material related to community-related activities for students such as Scouts, recreational sports, may be posted and/or sent home with the students, provided that these materials are provided at the expense of the organization requesting their distribution.

In addition, the Superintendent or Building Principal may approve the posting and distribution of information and materials of any community activity, film, lecture, etc. that is deemed to have particular educational merit. The posting and distribution of any material that has political, religious, sectarian, or in any way deemed to have discriminatory implications, is prohibited.

Adopted: February 14, 2000

Reviewed: January 11, 2016

Policy 701.22

FINANCIAL

701.22

Facility and Maintenance Funds

The School District will approve an annual budget that contains funds necessary to provide appropriate maintenance for existing buildings or facilities.

In addition, the board will approve an annual budget that contains funds for the Special Building Fund to provide finances for planned or emergency unplanned expenditures for building or facility construction or upkeep.

The superintendent will propose an annual budget with appropriate amounts for long range planning, maintenance, and construction.

Adopted: April 21, 2003

Reviewed: January 11, 2016

Use of School Computers

The School District approves the use of school computers for personal reasons by staff for personal email, developing familiarity with various software programs, and internet use during non-educational times. Non-educational times are before or after classes begin, during designated lunch hour, or during designated planning times.

The reason for permitting personal use during these specified times is to encourage staff training, understanding, and development in the utilization of computers which can be shared in an educational manner with students.

School computers will not be used to campaign for or against the election of a candidate or to support or oppose a ballot question nor may they be used in conducting personal business enterprises.

Adopted: January 12, 2004

Reviewed: January 11, 2016