

Board of Education Regular Meeting
Monday, April 14, 2025 8:00 PM
High School Library
P.O. Box 8400
Ravenna, NE 68869-8400

1. Call to Order and Roll Call - Open Meeting Law
2. Excuse Absent Board Members
3. The Pledge of Allegiance
4. Recitation of School Mission Statement: ***Preparing Students Today to Succeed Tomorrow: Family-Community-School***
5. Recitation of Board Mission Statement: ***Providing collaborative leadership to prepare students today to succeed tomorrow.***
6. Approval of Agenda
7. Financial Report
8. Consent Agenda
 - 8.1. Discuss, consider, and take all necessary action to minutes
 - 8.2. Discuss, consider, and take all necessary action to bills
 - 8.3. Notice of Meeting Publication: The notice for this board meeting was published in the April 9th Edition of *The Ravenna News*
 - 8.4. Discuss, consider, and take all action necessary to declaring surplus library books as surplus for immediate sale or disposal
 - 8.5. Discuss, consider, and take all action necessary to declaring used metal shop equipment as surplus for immediate sale or disposal
 - 8.6. Discuss, consider, and take all action necessary to declaring used desk as surplus for immediate sale or disposal
 - 8.7. Discuss, consider, and take all action necessary to declaring used 6' x 3' x 16" garden shed as surplus for immediate sale or disposal

9. Blue Jay Celebration of Success - HAL Students (Mrs. Stacie Loeffelholz)
10. Artist of the Month - None this month
11. Request to Address the Board and Correspondence
12. Information and Action Items
 - 12.1. Discuss, consider, and take all action necessary to approval of teaching contract for Madison Gross for the middle school science position for the 2025-26 contract term
 - 12.2. Discuss, consider, and take all action necessary to approval and adoption of a resolution authorizing the issuance of one or more series of the District's general obligation school building bonds, in the aggregate principal amount of not to exceed \$5,500,000, for the purpose of financing the construction of capital improvements and equipping and furnishing the same
 - 12.3. Discuss, consider, and take all action necessary to the revision of the school district's teacher evaluation instrument
 - 12.4. Discuss, consider, and take all action necessary to the review and purchase of the new elementary language arts curriculum
 - 12.5. Discuss, consider, and take all action necessary to classified staff compensation for the 2025-26 school year
 - 12.6. Discuss, consider, and take all action necessary to football field/track lighting
13. Discussion Items
 - 13.1. Discuss, consider, and take all action necessary to the girls high school wrestling program
 - 13.2. Discuss, consider, and take all action necessary to one-act directors' compensation on the 2025-26 extra duty schedule
 - 13.3. Discuss, consider, and take all action necessary to administrative compensation for the 2025-26 contract term (Possible Executive Session)
14. Elementary Principal's Report
15. Secondary Principal's Report

16. Superintendent's Report

17. Board Report

18. Positive Comments

19. Adjournment

Ravenna Public Schools

Family-Community-School

Preparing Students Today To Succeed Tomorrow



BELIEF STATEMENTS:

- We believe all students learn at different rates, in different ways, and are capable of success.
- We believe in supporting the academic, behavioral, social, and emotional needs of all students in a safe and positive environment.
- We believe education is a shared responsibility between family, school, and community.

The Ravenna Way

Ravenna Public Schools
Fund Balance Report
March 31st, 2025

Special Building

Last month ending balance	\$	390,101.65
Buffalo Co Taxes	\$	155,015.54
Sherman Co Taxes	\$	1,799.32
Settlement Checks	\$	-
Interest	\$	491.34
Check(s)	\$	(98.62)
Bank Statement Balance	\$	547,309.23
Outstanding Checks		\$0.00
Flex 9 mo. CD 043	\$	1,578,571.34
Interest	\$	13,586.23
Total	\$	2,139,466.80

Depreciation Fund

Last month ending balance	\$	567,061.72
Interest	\$	72.24
CD 428 Dep.	\$	-
Transfer	\$	-
Check(s)	\$	-
Bank Statement Balance	\$	567,133.96
5 Month Spec. CD 428	\$	-
Interest	\$	-
Total	\$	567,133.96

Employee Benefit Fund

Last month ending balance	\$	13,946.96
Deposit for Employee Benefits	\$	-
Interest	\$	1.78
Withdrawal to CD	\$	-
Bank Statement Balance	\$	13,948.74
Flex 9 mo. CD 094	\$	207,468.19
Interest	\$	3,480.35
x3372 13 mo CD	\$	-
Interest	\$	-
5 Month Spec. CD 427	\$	-
Interest	\$	-
Total	\$	224,897.28

Qualified Cap

Last month ending balance	\$	44,930.68
Buffalo Co Taxes	\$	33,153.35
Sherm Co Taxes	\$	385.29
US Treas.		
Interest	\$	-
check(s) Transfer to GF	\$	-
Bank Statement Balance	\$	78,469.32

PO Number	Invoice Number	Vendor Name	Invoice Date	Amount
Account Number		Detail Description		Amount
Checking Account ID	01	Fund Number 01	General	
	103694	Acellus Educational Services LLC	03/27/2025	10,000.00
01 1200 735 001 000		Comp Software Secon		5,000.00
01 1200 735 002 000		Comp Software Elem		5,000.00
Total	Acellus Educational Services LLC			10,000.00
	C-25950-JW	ARROW SEED COMPANY INC	03/26/2025	2,208.40
01 2620 610 001 000		GENERAL SUPPLIES		1,104.20
01 2620 610 002 000		GENERAL SUPPLIES		1,104.20
Total	ARROW SEED COMPANY INC			2,208.40
	2425-751workshop	Beyer, Thomas	04/09/2025	75.00
01 1100 810 002 000		FEES		75.00
	Beyer.April25	Beyer, Thomas	04/09/2025	6,680.00
01 2151 340 002 000		OTHER PROF. SERVICES		6,680.00
Total	Beyer, Thomas			6,755.00
	4905153979. March25	BLACK HILLS ENERGY	03/19/2025	174.61
01 2610 621 001 000		Fuel Secon		87.31
01 2610 621 002 000		Fuel Elem		87.30
	8985166782. March25	BLACK HILLS ENERGY	03/19/2025	5,874.50
01 2610 621 001 000		Fuel Secon		2,937.25
01 2610 621 002 000		Fuel Elem		2,937.25
Total	BLACK HILLS ENERGY			6,049.11
	election.3.11.25	BUFFALO COUNTY	03/11/2025	2,527.95
01 2310 890 000 000		Other Misc Exp		2,527.95
Total	BUFFALO COUNTY			2,527.95
	176215601030125	CHARTER COMMUNICATIONS	03/01/2025	22.41
01 1100 382 000 000		INTERNET SERVICES		22.41
	176215601047012 5	CHARTER COMMUNICATIONS	04/01/2025	22.41
01 1100 382 000 000		INTERNET SERVICES		22.41
Total	CHARTER COMMUNICATIONS			44.82
	357.March25	CITY OF RAVENNA	03/27/2025	670.17
01 2610 410 001 000		Water Sewer Secon		335.09
01 2610 410 002 000		Water Sewer Elem		335.08
	760.March25	CITY OF RAVENNA	03/27/2025	77.60
01 2610 410 001 000		Water Sewer Secon		38.80
01 2610 410 002 000		Water Sewer Elem		38.80
Total	CITY OF RAVENNA			747.77
	1470064	DAS State Accounting - Central Finance	03/12/2025	292.87
01 1100 382 000 000		INTERNET SERVICES		292.87
Total	DAS State Accounting - Central Finance			292.87
	000755CH	Diversified Drug Testing, LLC	03/24/2025	320.00
01 2710 890 000 000		Other Exp		320.00
Total	Diversified Drug Testing, LLC			320.00

PO Number	Invoice Number	Vendor Name	Invoice Date	Amount
Account Number		Detail Description		Amount
	7623275	ECOLAB PEST ELIM DIV	03/24/2025	81.85
01 2620 431 001 000		Con/ser Repair Secon		40.93
01 2620 431 002 000		Cont/ser Repair Elem		40.92
Total	ECOLAB PEST ELIM DIV			81.85
	180300.March	ESU #10	04/01/2025	32,126.23
01 2152 591 002 607		AUDIOLOGY SPED 3-5		17.02
01 2153 591 002 607		AUDIOLOGY SPED 0-2		17.02
01 2151 591 001 607		Audiology Secon		68.09
01 2151 591 002 607		Audiology Elem		68.09
01 2151 591 001 604		ESU SERVICES-Deaf Ed Sec.		502.61
01 2151 591 002 604		Deaf Ed Sped Elem.		502.61
01 2140 591 001 000		ESU SERVICES-LMHP		1,500.00
01 2140 591 002 000		ESU SERVICES-LMHP Elem		1,500.00
01 2142 591 002 606		PSYCH SERVICES SPED 3-5		645.22
01 2143 591 002 606		PSYC SERVICES SPED 0-2		645.22
01 2141 591 001 606		SCHOOL PSYCH		2,580.89
01 2141 591 002 606		Diagnostic Testing (School Psych)		2,580.89
01 1200 591 001 000		SPED SUPERVISION SEC.		1,216.08
01 1200 591 002 000		SPED SUPERVISION ELEM.		1,216.08
01 2153 591 002 602		SPEECH (0-2)		1,306.39
01 2152 591 002 602		PRE SCHL SPEECH (3-5)		1,968.53
01 2151 591 001 602		Speech Therapy		3,749.15
01 2151 591 002 602		Speech Therapy Elem		10,871.64
01 2181 591 002 605		VISION		438.14
01 1200 591 000 608		Vocational		116.92
01 1100 810 002 000		FEES		24.00
01 2212 330 001 000		Purch Prof Ser Secon		40.00
01 1291 591 002 603		PRE SPED Supervision (3-5)		275.82
01 1292 591 002 603		Pre Sped Services (0-2)		275.82
Total	ESU #10			32,126.23
	3613	Family Physical Therapy & Sports Center P.C.	03/19/2025	3,841.95
01 2173 320 002 000		PT Sped Services 0-2		200.90
01 2172 320 002 000		PT Sped Services 3-5		93.75
01 2171 320 002 000		PT Sped Services Elem		75.00
01 2172 320 002 000		PT Sped Services 3-5		142.50
01 2171 320 002 000		PT Sped Services Elem		441.75
01 2171 320 001 000		PT Sped Services Sec.		213.75
01 2161 320 002 000		PROFESSIONAL ED SERVICES		231.05
01 2161 320 001 000		PROFESSIONAL ED SERVICES		237.75
01 2163 320 002 000		OT Sped Services 0-2		404.00
01 2162 320 002 000		OT Services SPED 3-5		456.00
01 2161 320 002 000		PROFESSIONAL ED SERVICES		798.00
01 2161 320 001 000		PROFESSIONAL ED SERVICES		285.00
01 2151 320 001 000		Speech Therapy Services		262.50
Total	Family Physical Therapy & Sports Center P.C.			3,841.95
	837326.March25	FARMERS CO-OPERATIVE ASSOC	03/25/2025	4,070.33
01 2710 626 000 000		Gas And Oil		4,070.33
Total	FARMERS CO-OPERATIVE ASSOC			4,070.33
	11034038	Hamilton	04/01/2025	90.34
01 2510 382 001 000		Telephone Secon		45.17

PO Number	Invoice Number	Vendor Name	Invoice Date	Amount
Account Number		Detail Description		Amount
01 2510 382 002 000		Telephone Elem		45.17
	11036219	Hamilton	04/01/2025	40.67
01 2510 382 001 000		Telephone Secon		20.34
01 2510 382 002 000		Telephone Elem		20.33
	11037261	Hamilton	04/01/2025	284.40
01 2510 382 001 000		Telephone Secon		142.20
01 2510 382 002 000		Telephone Elem		142.20
Total Hamilton				<u>415.41</u>
	1242	Hands of Heartland	03/06/2025	6,005.07
01 1200 569 001 000		TUITION-OTHER		6,005.07
	1269	Hands of Heartland	04/04/2025	6,862.94
01 1200 569 001 000		TUITION-OTHER		6,862.94
Total Hands of Heartland				<u>12,868.01</u>
	855974010	HD Supply Formerly Home Depot Pro	03/19/2025	55.24
01 2610 610 001 000		Supplies Secon		27.62
01 2610 610 002 000		Supplies Elem		27.62
	8586355642	HD Supply Formerly Home Depot Pro	04/04/2025	284.40
01 2610 610 001 000		Supplies Secon		142.20
01 2610 610 002 000		Supplies Elem		142.20
	859357527	HD Supply Formerly Home Depot Pro	04/09/2025	35.64
01 2610 610 001 000		Supplies Secon		17.82
01 2610 610 002 000		Supplies Elem		17.82
Total HD Supply Formerly Home Depot Pro				<u>375.28</u>
	12800282.April25	Hometown Leasing	04/01/2025	765.95
01 1100 443 001 000		LEASED EQUIP		765.95
	GQ2407	Hometown Leasing	04/07/2025	5,700.00
01 1100 443 001 000		LEASED EQUIP		5,700.00
Total Hometown Leasing				<u>6,465.95</u>
	1482	Inner-PoleTesting	03/21/2025	90.00
01 2620 431 001 000		Con/ser Repair Secon		90.00
Total Inner-PoleTesting				<u>90.00</u>
	654659	Integrated Life Choices	02/28/2025	120.00
01 2712 519 001 000		Contracted Transpor		120.00
	654660	Integrated Life Choices	02/28/2025	905.24
01 1200 569 001 000		TUITION-OTHER		905.24
	654661	Integrated Life Choices	02/28/2025	494.13
01 1200 569 001 000		TUITION-OTHER		494.13
	660206	Integrated Life Choices	03/31/2025	2,160.00
01 2712 519 001 000		Contracted Transpor		2,160.00
	660209	Integrated Life Choices	03/31/2025	2,521.74
01 1200 569 001 000		TUITION-OTHER		2,521.74
	660210	Integrated Life Choices	03/31/2025	7,265.12
01 1200 569 001 000		TUITION-OTHER		7,265.12
Total Integrated Life Choices				<u>13,466.23</u>
	367367834	J. W. PEPPER & SON INC.	03/07/2025	27.94
01 1100 610 001 018		Music Materials		27.94
	367368765	J. W. PEPPER & SON INC.	03/07/2025	16.00
01 1100 610 001 018		Music Materials		16.00

PO Number	Invoice Number	Vendor Name	Invoice Date	Amount
Account Number		Detail Description		Amount
	367369377	J. W. PEPPER & SON INC.	03/07/2025	36.98
01 1100 610 001 018		Music Materials		36.98
	367384500	J. W. PEPPER & SON INC.	03/12/2025	79.00
01 1100 610 001 018		Music Materials		79.00
Total	J. W. PEPPER & SON INC.			159.92
	2460.Feb25	K & B PARTS	02/28/2025	324.51
01 2620 610 001 000		GENERAL SUPPLIES		63.56
01 2620 610 002 000		GENERAL SUPPLIES		63.55
01 2710 610 000 000		Tires And Parts		197.40
	2460.March25	K & B PARTS	03/31/2025	80.97
01 2710 610 000 000		Tires And Parts		80.97
Total	K & B PARTS			405.48
	1668	K12 Sign Language Solutions LLC	03/27/2025	2,146.25
01 2151 340 002 000		OTHER PROF. SERVICES		2,146.25
Total	K12 Sign Language Solutions LLC			2,146.25
	48275201	Kearney Winnelson Co.	03/18/2025	379.00
01 2620 610 002 000		GENERAL SUPPLIES		379.00
Total	Kearney Winnelson Co.			379.00
	25090	L & M MACHINE TOOLS, LTD	03/11/2025	163.80
01 1100 610 001 025		Instr Materials		163.80
Total	L & M MACHINE TOOLS, LTD			163.80
	travelmarch25	Loeffelholz, Stacie	03/07/2025	93.08
01 1100 580 001 000		Travel Secon		46.54
01 1100 580 002 000		Travel Elem		46.54
Total	Loeffelholz, Stacie			93.08
	2425-739	LUNCH FUND	04/02/2025	109.20
01 1100 890 002 000		Other Misc Exp Elem		109.20
Total	LUNCH FUND			109.20
	0030878804	Matheson Tri Gas INC	01/15/2025	264.29
01 1100 610 001 025		Instr Materials		264.29
Total	Matheson Tri Gas INC			264.29
	7985	MC AUTOMOTIVE	03/06/2025	1,887.78
01 2730 431 000 000		REPAIRS & MAINT.		1,887.78
Total	MC AUTOMOTIVE			1,887.78
	52744.March25	NE PUBLIC POWER DISTRICT	03/28/2025	133.74
01 2610 621 001 000		Fuel Secon		66.87
01 2610 621 002 000		Fuel Elem		66.87
	52749.March25	NE PUBLIC POWER DISTRICT	03/28/2025	48.42
01 2610 621 001 000		Fuel Secon		24.21
01 2610 621 002 000		Fuel Elem		24.21
	52754.March25	NE PUBLIC POWER DISTRICT	03/28/2025	32.63
01 2610 621 001 000		Fuel Secon		16.32
01 2610 621 002 000		Fuel Elem		16.31
	52759.March25	NE PUBLIC POWER DISTRICT	03/28/2025	3,605.65

PO Number	Invoice Number	Vendor Name	Invoice Date	Amount
Account Number		Detail Description		Amount
01 2610 621 001 000		Fuel Secon		1,802.83
01 2610 621 002 000		Fuel Elem		1,802.82
	52765.March25	NE PUBLIC POWER DISTRICT	03/28/2025	68.36
01 2610 621 001 000		Fuel Secon		34.18
01 2610 621 002 000		Fuel Elem		34.18
	52769.April25	NE PUBLIC POWER DISTRICT	04/07/2025	50.96
01 2610 621 001 000		Fuel Secon		25.48
01 2610 621 002 000		Fuel Elem		25.48
	52769.March25	NE PUBLIC POWER DISTRICT	03/04/2025	59.98
01 2610 621 001 000		Fuel Secon		29.99
01 2610 621 002 000		Fuel Elem		29.99
Total		NE PUBLIC POWER DISTRICT		3,999.74
	2022176248	ONE SOURCE	04/01/2025	42.00
01 2310 340 000 000		SERVICES		42.00
Total		ONE SOURCE		42.00
	RPS.ACT25	Our Lady of Lourdes Church	03/25/2025	125.00
01 1100 890 001 000		Other Misc Exp Secon		125.00
Total		Our Lady of Lourdes Church		125.00
	158099	PRAIRIE HILLS WIRELESS, LLC	04/01/2025	60.00
01 1100 382 000 000		INTERNET SERVICES		60.00
Total		PRAIRIE HILLS WIRELESS, LLC		60.00
	160675	Protex Central, Inc.	03/28/2025	420.00
01 2620 431 001 000		Con/ser Repair Secon		210.00
01 2620 431 002 000		Cont/ser Repair Elem		210.00
Total		Protex Central, Inc.		420.00
	news.March25	RAVENNA NEWS	03/31/2025	2,498.86
01 2310 540 000 000		Advertising & Print		2,498.86
Total		RAVENNA NEWS		2,498.86
	trash.April25	RAVENNA SANITATION	04/01/2025	981.00
01 2620 420 001 000		CLEANING SERVICES/TRASH		490.50
01 2620 420 002 000		CLEANING SERVICES/TRASH		490.50
Total		RAVENNA SANITATION		981.00
	ADMiles.March25	Schirmer, Anthony	03/26/2025	67.20
01 2212 580 001 000		Travel Secon		67.20
Total		Schirmer, Anthony		67.20
	DistNo.69Bond25	SHERMAN COUNTY	03/17/2025	238.34
01 2310 810 000 000		Dues And Fees		238.34
Total		SHERMAN COUNTY		238.34
	155491	Sodexo, Inc & Affiliates	04/03/2025	121.65
01 1100 580 001 000		Travel Secon		121.65
Total		Sodexo, Inc & Affiliates		121.65
	21126171	Soliant	02/02/2025	2,745.25
01 2151 340 001 000		OTHER PROF. SERVICES		2,745.25

PO Number	Invoice Number	Vendor Name	Invoice Date	Amount
Account Number		Detail Description		Amount
	21130826	Soliant	02/09/2025	1,540.50
01 2151 340 001 000		OTHER PROF. SERVICES		1,540.50
	21142499	Soliant	02/23/2025	869.00
01 2151 340 001 000		OTHER PROF. SERVICES		869.00
	21153881	Soliant	03/09/2025	908.50
01 2151 340 001 000		OTHER PROF. SERVICES		908.50
	21165771	Soliant	03/23/2025	474.00
01 2151 340 001 000		OTHER PROF. SERVICES		474.00
	21171301	Soliant	03/30/2025	2,291.00
01 2151 340 001 000		OTHER PROF. SERVICES		2,291.00
	21177375	Soliant	04/06/2025	2,249.13
01 2151 340 001 000		OTHER PROF. SERVICES		2,249.13
Total Soliant				<u>11,077.38</u>
	14021	Sport Safe Testing Service, Inc.	02/27/2025	518.00
01 2190 340 001 000		Testing		518.00
	14103	Sport Safe Testing Service, Inc.	04/01/2025	446.00
01 2190 340 001 000		Testing		446.00
Total Sport Safe Testing Service, Inc.				<u>964.00</u>
	377587	STELLING BRASS & WINDS	03/17/2025	124.00
01 1100 431 001 028		REPAIRS & MAINTENANCE - Contracted		124.00
Total STELLING BRASS & WINDS				<u>124.00</u>
	USBank.April25	U.S. Bank	03/25/2025	6,912.59
01 2510 531 000 000		POSTAGE		204.87
01 2710 626 000 000		Gas And Oil		25.00
01 1200 610 001 000		Gen Supplies		42.68
01 1100 890 001 000		Other Misc Exp Secon		971.18
01 3535 810 000 000		High Abilt Learn Registration		463.50
01 2130 610 000 000		Health Supplies		77.98
01 3535 610 000 000		High Abilt Learn Supplies		77.38
01 1200 810 001 000		Registration Secondary		10.82
01 1100 735 001 000		Comp Software Secon		68.00
01 1100 610 001 000		Gen Supplies Secon		87.00
01 1100 810 001 032		REGISTRATION		90.00
01 1100 890 001 000		Other Misc Exp Secon		299.95
01 1100 735 002 000		Comp Software Elem		999.00
01 1100 580 001 000		Travel Secon		193.91
01 1100 580 001 000		Travel Secon		(100.91)
01 1100 580 002 000		Travel Elem		193.91
01 1100 580 002 000		Travel Elem		(100.91)
01 1200 735 002 000		Comp Software Elem		18.05
01 1100 610 001 028		Instr Materials		656.06
01 1100 610 001 000		Gen Supplies Secon		20.49
01 1100 580 002 000		Travel Elem		110.00
01 1100 610 001 031		Instruc Materials		74.98
01 2710 626 000 000		Gas And Oil		62.44
01 2730 431 000 000		REPAIRS & MAINT.		1,352.43
01 2710 890 000 000		Other Exp		10.25
01 1100 610 001 028		Instr Materials		385.21
01 2220 640 001 000		Library Books Secon		334.81
01 2220 640 002 000		Library Books Elem		223.56
01 2620 610 001 000		GENERAL SUPPLIES		60.95
Total U.S. Bank				<u>6,912.59</u>

PO Number	Invoice Number	Vendor Name	Invoice Date	Amount
Account Number		Detail Description		Amount
	INV429825	UNITED LABORATORIES	03/12/2025	855.18
01 2610 610 001 000		Supplies Secon		427.59
01 2610 610 002 000		Supplies Elem		427.59
Total	UNITED LABORATORIES			855.18
	ASDconf2025	University of Nebraska-Lincoln, The	03/29/2025	215.00
01 1200 320 002 000		Purch Prof Serv Elem		107.50
01 1200 320 001 000		Purch Prof Ser Secon		107.50
Total	University of Nebraska-Lincoln, The			215.00
	VIN56125	Vendnet Holdings LLC	12/18/2024	560.00
01 2620 610 001 000		GENERAL SUPPLIES		560.00
	VNI55001	Vendnet Holdings LLC	11/17/2024	140.25
01 2620 610 001 000		GENERAL SUPPLIES		140.25
	VNI55017	Vendnet Holdings LLC	11/20/2024	52.50
01 2620 610 001 000		GENERAL SUPPLIES		52.50
Total	Vendnet Holdings LLC			752.75
	04960080202503	Verizon Business	04/01/2025	34.71
01 2510 382 001 000		Telephone Secon		17.36
01 2510 382 002 000		Telephone Elem		17.35
Total	Verizon Business			34.71
	6109469312	VERIZON WIRELESS	04/01/2025	107.44
01 2510 382 001 000		Telephone Secon		53.72
01 2510 382 002 000		Telephone Elem		53.72
Total	VERIZON WIRELESS			107.44
	10220940-01	VOSS LIGHTING	03/14/2025	204.00
01 2620 610 001 000		GENERAL SUPPLIES		102.00
01 2620 610 002 000		GENERAL SUPPLIES		102.00
Total	VOSS LIGHTING			204.00
	2502-122722	WILKE'S TRUE VALUE	02/25/2025	1.23
01 2620 610 001 000		GENERAL SUPPLIES		0.62
01 2620 610 002 000		GENERAL SUPPLIES		0.61
	2503-113321	WILKE'S TRUE VALUE	03/04/2025	18.99
01 2620 610 001 000		GENERAL SUPPLIES		9.50
01 2620 610 002 000		GENERAL SUPPLIES		9.49
	2503-113440	WILKE'S TRUE VALUE	03/06/2025	5.63
01 2620 610 001 000		GENERAL SUPPLIES		5.63
	2503-113773	WILKE'S TRUE VALUE	03/10/2025	35.56
01 2620 610 001 000		GENERAL SUPPLIES		35.56
	2503-113811	WILKE'S TRUE VALUE	03/10/2025	56.98
01 1100 610 001 025		Instr Materials		56.98
	2503-114032	WILKE'S TRUE VALUE	03/12/2025	16.14
01 1100 610 001 031		Instruc Materials		16.14
	2503-114189	WILKE'S TRUE VALUE	03/14/2025	63.20
01 3535 610 000 000		High Abilt Learn Supplies		63.20
	2503-114466	WILKE'S TRUE VALUE	03/17/2025	33.97
01 1100 610 001 000		Gen Supplies Secon		33.97
	2503-114522	WILKE'S TRUE VALUE	03/18/2025	3.32
01 2620 610 001 000		GENERAL SUPPLIES		3.32

PO Number	Invoice Number	Vendor Name	Invoice Date	Amount
Account Number		Detail Description		Amount
01 2620 610 001 000	2503-114524	WILKE'S TRUE VALUE GENERAL SUPPLIES	03/18/2025	21.63
01 2620 610 001 000	2503-115037	WILKE'S TRUE VALUE GENERAL SUPPLIES	03/25/2025	1.42
01 2620 610 001 000	2503-115039	WILKE'S TRUE VALUE GENERAL SUPPLIES	03/25/2025	5.34
01 2710 610 000 000	2503-115691	WILKE'S TRUE VALUE Tires And Parts	03/31/2025	25.64
Total WILKE'S TRUE VALUE				<hr/> 289.05
Fund Number 01				<hr/> 138,445.85
Checking Account ID 01				<hr/> 138,445.85

Expenditure Report by Op. Unit/Function

Account Number	Account Description	Revised Budget	During Month	Expenditures to Date	% of Budget	Balance at EOM	Encumbrances	Unencumbered Balance
01	General							
01 1100 111 001 000	SALARIES TEACHERS SECONDARY	923,742.00	75,366.76	600,036.13	64.96	323,705.87	0.00	323,705.87
01 1100 111 002 000	SALARIES TEACHERS ELEM.	971,972.00	75,371.98	591,745.10	60.88	380,226.90	0.00	380,226.90
01 1100 112 001 000	AIDES/COACHES	5,000.00	0.00	0.00	0.00	5,000.00	0.00	5,000.00
01 1100 120 001 000	SUBSTITUTE OR TEMPORARY SALARIES	3,000.00	0.00	0.00	0.00	3,000.00	0.00	3,000.00
01 1100 123 001 000	Sub Salaries Secon	25,000.00	4,481.25	37,914.99	151.66	(12,914.99)	0.00	(12,914.99)
01 1100 123 002 000	Sub Salaries Elem	20,000.00	2,685.00	25,628.92	128.14	(5,628.92)	0.00	(5,628.92)
01 1100 150 001 000	ADDITIONAL COMP. NON INSTRUCTIONAL STAFF	0.00	1,000.00	12,104.75	0.00	(12,104.75)	0.00	(12,104.75)
01 1100 151 001 000	ADDITIONAL COMP. TEACHERS/PROF. STAFF	130,000.00	9,764.57	83,656.06	64.35	46,343.94	0.00	46,343.94
01 1100 151 002 000	ADDITIONAL COMP. TEACHERS/PROF. STAFF	40,000.00	3,925.00	31,616.00	79.04	8,384.00	0.00	8,384.00
01 1100 152 001 000	ADDITIONAL COMP. AIDES	5,000.00	0.00	1,855.50	37.11	3,144.50	0.00	3,144.50
01 1100 210 001 000	GROUP INSURANCE-NON INSTRUCTIONAL	0.00	153.22	1,098.13	0.00	(1,098.13)	0.00	(1,098.13)
01 1100 211 001 000	Health Ins Secon	407,103.00	29,193.52	236,407.26	58.07	170,695.74	0.00	170,695.74
01 1100 211 002 000	Health Ins Elem	428,318.00	30,717.10	241,704.80	56.43	186,613.20	0.00	186,613.20
01 1100 212 001 000	GROUP INSURANCE-AIDES	25.00	0.00	0.06	0.24	24.94	0.00	24.94
01 1100 213 001 000	GROUP INS.-SUBS	1,000.00	416.16	1,257.76	125.78	(257.76)	0.00	(257.76)
01 1100 213 002 000	GROUP INS.-SUBS	7,500.00	182.85	699.20	9.32	6,800.80	0.00	6,800.80
01 1100 220 001 000	FICA-NON INSTRUCTIONAL	250.00	73.52	904.66	361.86	(654.66)	0.00	(654.66)
01 1100 221 001 000	Fica Secon	75,000.00	6,263.34	51,952.34	69.27	23,047.66	0.00	23,047.66
01 1100 221 002 000	Fica Elem	78,000.00	5,713.08	44,944.44	57.62	33,055.56	0.00	33,055.56
01 1100 222 001 000	FICA-COACHES/AIDES	1,000.00	0.00	141.97	14.20	858.03	0.00	858.03
01 1100 223 001 000	FICA-SUB SUBS	2,000.00	331.64	2,867.25	143.36	(867.25)	0.00	(867.25)
01 1100 223 002 000	FICA-SUB SUBS	2,000.00	200.52	1,942.22	97.11	57.78	0.00	57.78
01 1100 230 001 000	RETIREMENT- NON INSTRUCTIONAL	0.00	98.78	932.86	0.00	(932.86)	0.00	(932.86)
01 1100 231 001 000	RETIREMENT TEACHERS/ADMINS	95,000.00	8,409.11	67,382.77	70.93	27,617.23	0.00	27,617.23
01 1100 231 002 000	RETIREMENT TEACHERS/ADMIN	100,000.00	7,832.79	61,574.37	61.57	38,425.63	0.00	38,425.63
01 1100 232 001 000	RETIREMENT-COACHES/AIDES	400.00	0.00	1.78	0.45	398.22	0.00	398.22
01 1100 233 001 000	RETIREMENT-SUBS	200.00	223.27	1,706.17	853.09	(1,506.17)	0.00	(1,506.17)
01 1100 233 002 000	RETIREMENT-SUBS	200.00	113.05	1,050.53	525.27	(850.53)	0.00	(850.53)
01 1100 280 001 000	NON INSTRUCTIONAL HSA	0.00	27.83	199.00	0.00	(199.00)	0.00	(199.00)
01 1100 281 001 000	CASH IN LIEU/HSA	20,000.00	2,129.91	14,463.63	72.32	5,536.37	0.00	5,536.37
01 1100 281 002 000	CASH IN LIEU/HSA	25,000.00	2,739.33	21,104.59	84.42	3,895.41	0.00	3,895.41
01 1100 283 001 000	UNEMPLOYMENT COMP OR INS	100.00	73.27	219.21	219.21	(119.21)	0.00	(119.21)
01 1100 283 002 000	UNEMPLOYMENT COMP OR INS	100.00	32.13	121.73	121.73	(21.73)	0.00	(21.73)
01 1100 330 001 000	ASSEMBLIES	5,000.00	0.00	0.00	0.00	5,000.00	0.00	5,000.00
01 1100 330 002 000	ASSEMBLIES	5,000.00	0.00	0.00	0.00	5,000.00	0.00	5,000.00
01 1100 334 000 000	Mileage for Psyche Services	2,500.00	0.00	0.00	0.00	2,500.00	0.00	2,500.00
01 1100 382 000 000	INTERNET SERVICES	7,500.00	397.69	4,503.81	60.05	2,996.19	0.00	2,996.19
01 1100 382 001 000	Distance Education	0.00	0.00	0.00	0.00	0.00	0.00	0.00
01 1100 431 001 000	REPAIRS & MAINTENANCE - Contracted	0.00	0.00	0.00	0.00	0.00	0.00	0.00
01 1100 431 002 000	REPAIRS & MAINTENANCE - Contracted	0.00	0.00	0.00	0.00	0.00	0.00	0.00
01 1100 443 001 000	LEASED EQUIP	10,000.00	6,465.95	12,593.55	125.94	(2,593.55)	0.00	(2,593.55)
01 1100 443 002 000	LEASED EQUIP	2,500.00	0.00	0.00	0.00	2,500.00	0.00	2,500.00
01 1100 580 001 000	Travel Secon	5,000.00	261.19	1,158.38	23.17	3,841.62	0.00	3,841.62
01 1100 580 002 000	Travel Elem	2,000.00	249.54	1,187.54	59.38	812.46	0.00	812.46
01 1100 591 001 000	ESU SERVICES-LMHP	30,000.00	0.00	0.00	0.00	30,000.00	0.00	30,000.00
01 1100 610 001 000	Gen Supplies Secon	15,000.00	141.46	3,222.43	21.48	11,777.57	0.00	11,777.57
01 1100 610 002 000	Gen Supplies Elem	15,000.00	0.00	1,171.31	7.81	13,828.69	0.00	13,828.69
01 1100 640 001 000	Textbooks Secon	30,000.00	0.00	(678.00)	(2.26)	30,678.00	0.00	30,678.00

Expenditure Report by Op. Unit/Function

		General Fund						
Account Number	Account Description	Revised Budget	During Month	Expenditures to Date	% of Budget	Balance at EOM	Encumbrances	Unencumbered Balance
01 1100 640 002 000	Textbooks Elem	30,000.00	0.00	1,210.42	4.03	28,789.58	0.00	28,789.58
01 1100 733 001 000	Equipment Secon	10,000.00	0.00	0.00	0.00	10,000.00	0.00	10,000.00
01 1100 733 002 000	Equipment Elem	7,500.00	0.00	0.00	0.00	7,500.00	0.00	7,500.00
01 1100 734 001 000	Comp Equip Secon	40,000.00	0.00	235.60	0.59	39,764.40	0.00	39,764.40
01 1100 734 002 000	Comp Equip Elem	20,000.00	0.00	0.00	0.00	20,000.00	0.00	20,000.00
01 1100 735 001 000	Comp Software Secon	30,000.00	68.00	18,659.64	62.20	11,340.36	0.00	11,340.36
01 1100 735 002 000	Comp Software Elem	15,000.00	999.00	13,200.11	88.00	1,799.89	0.00	1,799.89
01 1100 810 001 000	FEES	2,500.00	0.00	803.40	32.14	1,696.60	0.00	1,696.60
01 1100 810 002 000	FEES	1,000.00	99.00	419.00	41.90	581.00	0.00	581.00
01 1100 890 001 000	Other Misc Exp Secon	3,000.00	1,396.13	2,333.06	77.77	666.94	0.00	666.94
01 1100 890 002 000	Other Misc Exp Elem	1,000.00	109.20	534.96	53.50	465.04	0.00	465.04
1100 SALARIES		3,656,410.00	277,706.14	2,197,789.39	60.11	1,458,620.61	0.00	1,458,620.61
01 1160 111 002 000	SALARIES TEACHERS POVERTY	67,000.00	0.00	5,687.50	8.49	61,312.50	0.00	61,312.50
01 1160 211 002 000	Poverty Program Health Ins	21,000.00	0.00	1,731.60	8.25	19,268.40	0.00	19,268.40
01 1160 221 002 000	Poverty Program FICA	5,000.00	0.00	403.36	8.07	4,596.64	0.00	4,596.64
01 1160 231 002 000	Poverty Program Retire	7,000.00	0.00	561.80	8.03	6,438.20	0.00	6,438.20
01 1160 281 002 000	TEACHERS/PRINCIPALS HSA	0.00	0.00	314.57	0.00	(314.57)	0.00	(314.57)
1160 POVERTY		100,000.00	0.00	8,698.83	8.70	91,301.17	0.00	91,301.17
01 1190 111 002 000	SALARIES TEACHERS PRE K	26,000.00	2,015.62	16,124.96	62.02	9,875.04	0.00	9,875.04
01 1190 112 002 000	PreK Para	35,000.00	1,907.55	11,110.23	31.74	23,889.77	0.00	23,889.77
01 1190 122 002 000	Sub Paras Salary	0.00	0.00	663.67	0.00	(663.67)	0.00	(663.67)
01 1190 123 002 000	PreK Subs	2,000.00	70.00	770.00	38.50	1,230.00	0.00	1,230.00
01 1190 211 002 000	PreK Health	27,000.00	1,172.61	9,375.67	34.72	17,624.33	0.00	17,624.33
01 1190 212 002 000	GROUP INSURANCE-AIDES	10,000.00	0.00	9.57	0.10	9,990.43	0.00	9,990.43
01 1190 221 002 000	PreK Fica	5,000.00	151.05	1,208.41	24.17	3,791.59	0.00	3,791.59
01 1190 222 002 000	FICA-AIDES	2,500.00	145.93	900.70	36.03	1,599.30	0.00	1,599.30
01 1190 223 002 000	FICA-SUB SUBS	300.00	5.35	58.88	19.63	241.12	0.00	241.12
01 1190 231 002 000	PreK Retire	2,500.00	199.10	1,592.80	63.71	907.20	0.00	907.20
01 1190 232 002 000	RETIREMENT AIDES	4,000.00	188.42	942.23	23.56	3,057.77	0.00	3,057.77
01 1190 233 002 000	RETIREMENT-SUBS	250.00	0.00	55.32	22.13	194.68	0.00	194.68
01 1190 610 002 000	PreK Supplies	500.00	0.00	0.00	0.00	500.00	0.00	500.00
01 1190 890 002 000	PreK Misc Exp	500.00	0.00	0.00	0.00	500.00	0.00	500.00
1190 PREK		115,550.00	5,855.63	42,812.44	37.05	72,737.56	0.00	72,737.56
01 1200 111 001 000	SPED teachers	210,000.00	14,125.00	114,964.31	54.74	95,035.69	0.00	95,035.69
01 1200 111 002 000	SALARIES TEACHERS SPED ELEM.	225,000.00	18,859.38	150,875.04	67.06	74,124.96	0.00	74,124.96
01 1200 112 001 000	SPED Paras	160,000.00	14,316.43	128,659.86	80.41	31,340.14	0.00	31,340.14
01 1200 112 002 000	Aide Elem	140,000.00	8,458.18	82,087.75	58.63	57,912.25	0.00	57,912.25
01 1200 116 001 000	Nurse Sp Ed Services	750.00	0.00	0.00	0.00	750.00	0.00	750.00
01 1200 116 002 000	Nurse Sp Ed Services	250.00	0.00	0.00	0.00	250.00	0.00	250.00
01 1200 122 001 000	Sub Paras Salary	1,500.00	0.00	1,172.70	78.18	327.30	0.00	327.30
01 1200 122 002 000	Sub Paras Salary	0.00	1,033.60	1,033.60	0.00	(1,033.60)	0.00	(1,033.60)
01 1200 123 001 000	Sub Secon	5,000.00	270.00	650.00	13.00	4,350.00	0.00	4,350.00
01 1200 123 002 000	Sub Elem	7,500.00	470.00	3,485.00	46.47	4,015.00	0.00	4,015.00
01 1200 132 001 000	OT - AIDES/PARAS	1,500.00	0.00	1,274.24	84.95	225.76	0.00	225.76
01 1200 132 002 000	OT - AIDES/PARAS	250.00	0.00	9.77	3.91	240.23	0.00	240.23
01 1200 151 001 000	ADDITIONAL COMP. TEACHERS/PROF. STAFF	10,000.00	818.18	6,545.44	65.45	3,454.56	0.00	3,454.56
01 1200 211 001 000	Health Ins	60,000.00	3,967.19	32,315.95	53.86	27,684.05	0.00	27,684.05
01 1200 211 002 000	Health Ins Elem	85,000.00	6,669.03	52,656.74	61.95	32,343.26	0.00	32,343.26
01 1200 212 001 000	GROUP INSURANCE-AIDES	20,000.00	1,578.33	12,946.55	64.73	7,053.45	0.00	7,053.45
01 1200 212 002 000	GROUP INSURANCE-AIDES	25,000.00	1,897.05	17,954.75	71.82	7,045.25	0.00	7,045.25
01 1200 213 001 000	GROUP INS.-SUBS	200.00	40.49	40.60	20.30	159.40	0.00	159.40
01 1200 213 002 000	GROUP INS.-SUBS	200.00	80.98	144.20	72.10	55.80	0.00	55.80
01 1200 216 001 000	Health Ins. NURSE	100.00	0.00	0.00	0.00	100.00	0.00	100.00

Expenditure Report by Op. Unit/Function

		General Fund						
Account Number	Account Description	Revised Budget	During Month	Expenditures to Date	% of Budget	Balance at EOM	Encumbrances	Unencumbered Balance
01 1200 216 002 000	Health Ins-NURSE	100.00	0.00	0.00	0.00	100.00	0.00	100.00
01 1200 221 001 000	Fica Secon	15,000.00	1,096.15	8,917.45	59.45	6,082.55	0.00	6,082.55
01 1200 221 002 000	Fica Elem	20,000.00	1,400.41	11,206.15	56.03	8,793.85	0.00	8,793.85
01 1200 222 001 000	FICA-AIDES	10,000.00	1,066.88	9,754.74	97.55	245.26	0.00	245.26
01 1200 222 002 000	FICA-AIDES	8,500.00	610.31	5,454.48	64.17	3,045.52	0.00	3,045.52
01 1200 223 001 000	FICA-SUB SUBS	400.00	19.57	48.66	12.17	351.34	0.00	351.34
01 1200 223 002 000	FICA-SUB SUBS	750.00	33.78	262.77	35.04	487.23	0.00	487.23
01 1200 226 001 000	Fica-NURSE	100.00	0.00	0.00	0.00	100.00	0.00	100.00
01 1200 226 002 000	Fica-NURSE	50.00	0.00	0.00	0.00	50.00	0.00	50.00
01 1200 231 001 000	RETIREMENT TEACHERS/ADMINS	20,000.00	1,395.24	11,355.95	56.78	8,644.05	0.00	8,644.05
01 1200 231 002 000	RETIREMENT TEACHERS/ADMINS	25,000.00	1,862.89	14,903.12	59.61	10,096.88	0.00	10,096.88
01 1200 232 001 000	RETIREMENT AIDES	17,500.00	1,403.78	12,705.41	72.60	4,794.59	0.00	4,794.59
01 1200 232 002 000	RETIREMENT AIDES	15,000.00	727.82	7,789.99	51.93	7,210.01	0.00	7,210.01
01 1200 233 001 000	RETIREMENT-SUBS	250.00	19.76	29.64	11.86	220.36	0.00	220.36
01 1200 233 002 000	RETIREMENT-SUBS	100.00	39.52	136.83	136.83	(36.83)	0.00	(36.83)
01 1200 236 001 000	Retire-NURSE	100.00	0.00	0.00	0.00	100.00	0.00	100.00
01 1200 236 002 000	Retire-NURSE	50.00	0.00	0.00	0.00	50.00	0.00	50.00
01 1200 281 001 000	CASH IN LIEU/HSA	5,000.00	0.00	0.00	0.00	5,000.00	0.00	5,000.00
01 1200 282 001 000	INSTRUCTIONAL AIDES HSA	150.00	126.08	1,015.23	676.82	(865.23)	0.00	(865.23)
01 1200 282 002 000	INSTRUCTIONAL AIDES HSA	3,000.00	254.72	2,593.06	86.44	406.94	0.00	406.94
01 1200 283 001 000	UNEMPLOYMENT COMP OR INS	0.00	7.15	7.15	0.00	(7.15)	0.00	(7.15)
01 1200 283 002 000	INS/HSA Cont.	50.00	14.30	25.31	50.62	24.69	0.00	24.69
01 1200 286 001 000	NURSE-HSA	25.00	0.00	0.00	0.00	25.00	0.00	25.00
01 1200 286 002 000	NURSE-HSA	25.00	0.00	0.00	0.00	25.00	0.00	25.00
01 1200 320 001 000	Purch Prof Ser Secon	10,000.00	107.50	107.50	1.08	9,892.50	0.00	9,892.50
01 1200 320 002 000	Purch Prof Serv Elem	5,000.00	107.50	107.50	2.15	4,892.50	0.00	4,892.50
01 1200 330 001 000	Contracted Services	2,500.00	0.00	220.00	8.80	2,280.00	0.00	2,280.00
01 1200 330 002 000	Contracted Services	0.00	0.00	440.00	0.00	(440.00)	0.00	(440.00)
01 1200 520 001 000	INSURANCE(Property, Liability)	100.00	0.00	0.00	0.00	100.00	0.00	100.00
01 1200 569 001 000	TUITION-OTHER	200,000.00	24,054.24	142,152.78	71.08	57,847.22	0.00	57,847.22
01 1200 569 002 000	TUITION-OTHER	50,000.00	0.00	2,614.69	5.23	47,385.31	0.00	47,385.31
01 1200 580 001 000	Travel Secon	250.00	0.00	288.48	115.39	(38.48)	0.00	(38.48)
01 1200 580 002 000	Travel Elem	250.00	0.00	288.49	115.40	(38.49)	0.00	(38.49)
01 1200 591 001 000	SPED SUPERVISION SEC.	20,000.00	1,216.08	11,060.04	55.30	8,939.96	0.00	8,939.96
01 1200 591 002 000	SPED SUPERVISION ELEM.	20,000.00	1,216.08	10,936.29	54.68	9,063.71	0.00	9,063.71
01 1200 610 001 000	Gen Supplies	7,500.00	42.68	1,212.69	16.17	6,287.31	0.00	6,287.31
01 1200 610 002 000	Gen Supplies Elem	5,000.00	0.00	2,212.22	44.24	2,787.78	0.00	2,787.78
01 1200 640 001 000	Textbooks	750.00	0.00	0.00	0.00	750.00	0.00	750.00
01 1200 640 002 000	Textbooks Elem	600.00	0.00	0.00	0.00	600.00	0.00	600.00
01 1200 641 001 000	Digital Materials	200.00	0.00	0.00	0.00	200.00	0.00	200.00
01 1200 641 002 000	Digital Mat./EBOOKS	100.00	0.00	0.00	0.00	100.00	0.00	100.00
01 1200 733 001 000	Equipment Furn Secon	2,000.00	0.00	0.00	0.00	2,000.00	0.00	2,000.00
01 1200 733 002 000	Furniture Equip Elem	1,000.00	0.00	0.00	0.00	1,000.00	0.00	1,000.00
01 1200 734 001 000	Comp Equip Secon	2,000.00	0.00	0.00	0.00	2,000.00	0.00	2,000.00
01 1200 734 002 000	Computer Equip Elem	1,000.00	0.00	0.00	0.00	1,000.00	0.00	1,000.00
01 1200 735 001 000	Comp Software Secon	1,000.00	5,000.00	5,298.99	529.90	(4,298.99)	0.00	(4,298.99)
01 1200 735 002 000	Comp Software Elem	610.00	5,018.05	5,415.98	887.87	(4,805.98)	0.00	(4,805.98)
01 1200 810 001 000	Registration Secondary	250.00	10.82	195.10	78.04	54.90	0.00	54.90
01 1200 810 002 000	Registration Elem	1,000.00	0.00	245.00	24.50	755.00	0.00	755.00
1200	SPEDICAL ED School Age	1,424,510.00	119,435.15	875,818.19	61.48	548,691.81	0.00	548,691.81
01 1291 610 002 000	PRE Supplies	3,000.00	0.00	0.00	0.00	3,000.00	0.00	3,000.00
01 1291 640 002 000	Periodicals (3-5)	300.00	0.00	0.00	0.00	300.00	0.00	300.00
01 1291 733 000 000	Equipment (3-5)	1,700.00	0.00	0.00	0.00	1,700.00	0.00	1,700.00
1291	SPED AGES 3-5	5,000.00	0.00	0.00	0.00	5,000.00	0.00	5,000.00

Expenditure Report by Op. Unit/Function

		General Fund						
Account Number	Account Description	Revised Budget	During Month	Expenditures to Date	% of Budget	Balance at EOM	Encumbrances	Unencumbered Balance
01 2120 111 001 000	Counselor Sal Secon	60,000.00	4,905.50	39,627.24	66.05	20,372.76	0.00	20,372.76
01 2120 111 002 000	Counselor Sal Elem	16,000.00	1,226.37	9,810.96	61.32	6,189.04	0.00	6,189.04
01 2120 211 001 000	Health Ins. Secon	15,000.00	1,023.68	8,206.15	54.71	6,793.85	0.00	6,793.85
01 2120 211 002 000	Health Ins. Elem	3,715.00	255.92	2,032.70	54.72	1,682.30	0.00	1,682.30
01 2120 221 001 000	Fica Secon	5,000.00	359.21	2,902.75	58.06	2,097.25	0.00	2,097.25
01 2120 221 002 000	Fica Elem	1,500.00	89.80	718.61	47.91	781.39	0.00	781.39
01 2120 231 001 000	Retirement Secon	6,000.00	484.56	3,914.33	65.24	2,085.67	0.00	2,085.67
01 2120 231 002 000	Retirement Elem	1,500.00	121.14	969.12	64.61	530.88	0.00	530.88
01 2120 281 001 000	TEACHERS/PRINCIPALS HSA	2,500.00	184.10	1,475.81	59.03	1,024.19	0.00	1,024.19
01 2120 281 002 000	TEACHERS/PRINCIPALS HSA	750.00	46.03	365.60	48.75	384.40	0.00	384.40
01 2120 320 001 000	Purch Prof Ser Secon	1,250.00	0.00	40.00	3.20	1,210.00	0.00	1,210.00
01 2120 320 002 000	Purch Prof Ser Elem	1,000.00	0.00	0.00	0.00	1,000.00	0.00	1,000.00
01 2120 580 001 000	Travel Secon	500.00	0.00	0.00	0.00	500.00	0.00	500.00
01 2120 580 002 000	Travel Elem	500.00	0.00	0.00	0.00	500.00	0.00	500.00
01 2120 610 001 000	Supplies Secon	1,000.00	0.00	593.49	59.35	406.51	0.00	406.51
01 2120 610 002 000	Supplies Elem	1,000.00	0.00	11.97	1.20	988.03	0.00	988.03
01 2120 640 001 000	BOOKS & PERIODICALS	2,500.00	0.00	0.00	0.00	2,500.00	0.00	2,500.00
01 2120 640 002 000	Resource Texts	150.00	0.00	0.00	0.00	150.00	0.00	150.00
01 2120 735 001 000	Computer Software	100.00	0.00	0.00	0.00	100.00	0.00	100.00
01 2120 810 000 000	REGISTRATION	1,000.00	0.00	250.00	25.00	750.00	0.00	750.00
2120 COUNSELOR		120,965.00	8,696.31	70,918.73	58.63	50,046.27	0.00	50,046.27
01 2130 116 000 000	SALARIES -Professional Non-Cert. (Nurse)	38,000.00	3,138.78	26,449.29	69.60	11,550.71	0.00	11,550.71
01 2130 216 000 000	GROUP INS.-NURSE	6,500.00	511.01	4,136.62	63.64	2,363.38	0.00	2,363.38
01 2130 226 000 000	FICA-NURSE	3,000.00	237.47	2,001.75	66.73	998.25	0.00	998.25
01 2130 236 000 000	RETIREMENT-NURSE	3,750.00	310.04	2,612.58	69.67	1,137.42	0.00	1,137.42
01 2130 286 000 000	NURSE-HSA	1,000.00	89.70	726.16	72.62	273.84	0.00	273.84
01 2130 320 001 000	Purch Prof Ser Secon	50.00	0.00	0.00	0.00	50.00	0.00	50.00
01 2130 320 002 000	Purch Prof Serv Elem	50.00	0.00	0.00	0.00	50.00	0.00	50.00
01 2130 580 000 000	Travel	200.00	0.00	0.00	0.00	200.00	0.00	200.00
01 2130 610 000 000	Health Supplies	5,000.00	77.98	2,766.18	55.32	2,233.82	0.00	2,233.82
01 2130 610 001 000	Instruc Mater Secon	100.00	0.00	0.00	0.00	100.00	0.00	100.00
01 2130 610 002 000	Instruc Mater Elem	200.00	0.00	0.00	0.00	200.00	0.00	200.00
01 2130 733 000 000	Equipment	300.00	0.00	0.00	0.00	300.00	0.00	300.00
01 2130 810 000 000	Dues And Fees	150.00	0.00	0.00	0.00	150.00	0.00	150.00
2130 NURSE		58,300.00	4,364.98	38,692.58	66.37	19,607.42	0.00	19,607.42
01 2131 116 001 000	SALARIES -Professional Non-Cert. (Nurse)	14,000.00	1,115.17	9,130.52	65.22	4,869.48	0.00	4,869.48
01 2131 116 002 000	SALARIES -Professional Non-Cert. (Nurse)	14,000.00	1,115.16	9,130.52	65.22	4,869.48	0.00	4,869.48
01 2131 216 001 000	GROUP INS.-NURSE	2,250.00	181.54	1,428.20	63.48	821.80	0.00	821.80
01 2131 216 002 000	GROUP INS.-NURSE	2,250.00	181.58	1,428.22	63.48	821.78	0.00	821.78
01 2131 226 001 000	FICA-NURSE	1,250.00	84.37	691.11	55.29	558.89	0.00	558.89
01 2131 226 002 000	FICA-NURSE	1,250.00	84.34	690.98	55.28	559.02	0.00	559.02
01 2131 236 001 000	RETIREMENT-NURSE	1,500.00	110.16	901.91	60.13	598.09	0.00	598.09
01 2131 236 002 000	RETIREMENT-NURSE	1,500.00	110.15	901.90	60.13	598.10	0.00	598.10
01 2131 286 001 000	NURSE-HSA	1,000.00	31.87	250.68	25.07	749.32	0.00	749.32
01 2131 286 002 000	NURSE-HSA	1,000.00	31.87	250.68	25.07	749.32	0.00	749.32
2131 HEALTH SERVICES SPED-NURSE		40,000.00	3,046.21	24,804.72	62.01	15,195.28	0.00	15,195.28
01 2140 111 000 000	SALARIES TEACHERS/PROFESSIONAL STAFF	7,000.00	0.00	0.00	0.00	7,000.00	0.00	7,000.00
01 2140 211 000 000	GROUP INSURANCE TEACHERS/ADMINS	1,000.00	0.00	0.00	0.00	1,000.00	0.00	1,000.00
01 2140 221 000 000	FICA TEACHERS/ADMIN	850.00	0.00	0.00	0.00	850.00	0.00	850.00
01 2140 231 000 000	RETIREMENT TEACHERS/ADMINS	850.00	0.00	0.00	0.00	850.00	0.00	850.00

Expenditure Report by Op. Unit/Function

		General Fund							
Account Number	Account Description	Revised Budget	During Month	Expenditures to Date	% of Budget	Balance at EOM	Encumbrances	Unencumbered Balance	
01 2140 281 000 000	CASH IN LIEU TEACHERS/HSA	300.00	0.00	0.00	0.00	300.00	0.00	300.00	
01 2140 591 001 000	ESU SERVICES-LMHP	15,000.00	1,500.00	10,500.00	70.00	4,500.00	0.00	4,500.00	
01 2140 591 002 000	ESU SERVICES-LMHP Elem	15,000.00	1,500.00	10,500.00	70.00	4,500.00	0.00	4,500.00	
2140	PSYCHOLOGICAL SERVICES	40,000.00	3,000.00	21,000.00	52.50	19,000.00	0.00	19,000.00	
01 2151 320 001 000	Speech Therapy Services	0.00	262.50	3,353.25	0.00	(3,353.25)	0.00	(3,353.25)	
01 2151 340 001 000	OTHER PROF. SERVICES	0.00	11,077.38	24,033.38	0.00	(24,033.38)	0.00	(24,033.38)	
01 2151 340 002 000	OTHER PROF. SERVICES	55,000.00	8,826.25	45,226.25	82.23	9,773.75	0.00	9,773.75	
2151	SPEECH PATH/AUDIOLOGY-SPED School Age	55,000.00	20,166.13	72,612.88	132.02	(17,612.88)	0.00	(17,612.88)	
01 2161 320 001 000	PROFESSIONAL ED SERVICES	5,000.00	522.75	5,595.05	111.90	(595.05)	0.00	(595.05)	
01 2161 320 002 000	PROFESSIONAL ED SERVICES	15,500.00	1,029.05	9,166.55	59.14	6,333.45	0.00	6,333.45	
01 2161 569 001 000	TUITION-OTHER	2,500.00	0.00	0.00	0.00	2,500.00	0.00	2,500.00	
01 2161 569 002 000	OT Sped School Age	2,500.00	0.00	0.00	0.00	2,500.00	0.00	2,500.00	
2161	OCCUPATIONAL THERAPY-SPED SCHOOL AGE	25,500.00	1,551.80	14,761.60	57.89	10,738.40	0.00	10,738.40	
01 2162 320 002 000	OT Services SPED 3-5	3,500.00	456.00	3,204.05	91.54	295.95	0.00	295.95	
01 2162 569 002 000	OT Sped 3-5	3,000.00	0.00	0.00	0.00	3,000.00	0.00	3,000.00	
2162	OCCUPATIONAL THERAPY-SPED 3-5	6,500.00	456.00	3,204.05	49.29	3,295.95	0.00	3,295.95	
01 2163 320 002 000	OT Sped Services 0-2	5,000.00	404.00	4,654.90	93.10	345.10	0.00	345.10	
2163	OCCUPATIONAL THERAPY-SPED 0-2	5,000.00	404.00	4,654.90	93.10	345.10	0.00	345.10	
01 2171 320 001 000	PT Sped Services Sec.	4,000.00	213.75	2,202.00	55.05	1,798.00	0.00	1,798.00	
01 2171 320 002 000	PT Sped Services Elem	15,000.00	516.75	6,723.75	44.83	8,276.25	0.00	8,276.25	
01 2171 569 001 000	PT Sped School Age	500.00	0.00	0.00	0.00	500.00	0.00	500.00	
01 2171 569 002 000	PT Sped School Age	500.00	0.00	0.00	0.00	500.00	0.00	500.00	
2171	PHYSICAL THERAPY-SPED SCHOOL AGE	20,000.00	730.50	8,925.75	44.63	11,074.25	0.00	11,074.25	
01 2172 320 002 000	PT Sped Services 3-5	2,500.00	236.25	1,230.00	49.20	1,270.00	0.00	1,270.00	
01 2172 569 002 000	PT 3-4 Sped	2,500.00	0.00	0.00	0.00	2,500.00	0.00	2,500.00	
2172	PHYSICAL THERAPY:SPED 3-5	5,000.00	236.25	1,230.00	24.60	3,770.00	0.00	3,770.00	
01 2173 320 002 000	PT Sped Services 0-2	0.00	200.90	3,559.62	0.00	(3,559.62)	0.00	(3,559.62)	
2173	PHYSICAL THERAPY:SPED 0-2	0.00	200.90	3,559.62	0.00	(3,559.62)	0.00	(3,559.62)	
01 2190 110 001 000	Act Trans Sal Secon	20,000.00	1,815.45	13,850.57	69.25	6,149.43	0.00	6,149.43	
01 2190 110 002 000	Act Trans Sal Elem	1,000.00	0.00	0.00	0.00	1,000.00	0.00	1,000.00	
01 2190 210 001 000	GROUP INSURANCE-NON INSTRUCTIONAL	750.00	3.56	512.92	68.39	237.08	0.00	237.08	
01 2190 220 001 000	FICA-NON INSTRUCTIONAL	1,500.00	138.77	1,042.13	69.48	457.87	0.00	457.87	
01 2190 220 002 000	FICA-NON INSTRUCTIONAL	100.00	0.00	0.00	0.00	100.00	0.00	100.00	
01 2190 230 001 000	RETIREMENT- NON INSTRUCTIONAL	1,000.00	129.76	732.42	73.24	267.58	0.00	267.58	
01 2190 230 002 000	RETIREMENT- NON INSTRUCTIONAL	115.00	0.00	0.00	0.00	115.00	0.00	115.00	
01 2190 340 001 000	Testing	1,500.00	964.00	2,905.00	193.67	(1,405.00)	0.00	(1,405.00)	
01 2190 580 002 000	Meals/mileage	100.00	0.00	0.00	0.00	100.00	0.00	100.00	
2190	ACT TRANS	26,065.00	3,051.54	19,043.04	73.06	7,021.96	0.00	7,021.96	
01 2212 111 001 000	SALARIES TEACHERS STAFF. DEV	2,500.00	0.00	0.00	0.00	2,500.00	0.00	2,500.00	
01 2212 111 002 000	SALARIES TEACHERS STAFF DEV. ELEM.	2,500.00	0.00	0.00	0.00	2,500.00	0.00	2,500.00	
01 2212 123 001 000	Staff Development	300.00	0.00	0.00	0.00	300.00	0.00	300.00	
01 2212 123 002 000	Staff Development	300.00	0.00	0.00	0.00	300.00	0.00	300.00	
01 2212 211 001 000	HEALTH INSURANCE	200.00	0.00	0.00	0.00	200.00	0.00	200.00	
01 2212 211 002 000	HEALTH INSURANCE	200.00	0.00	0.00	0.00	200.00	0.00	200.00	
01 2212 221 001 000	Staff Dev Fica	500.00	0.00	0.00	0.00	500.00	0.00	500.00	
01 2212 221 002 000	Staff Dev Fica	500.00	0.00	0.00	0.00	500.00	0.00	500.00	
01 2212 231 001 000	RETIREMENT	250.00	0.00	0.00	0.00	250.00	0.00	250.00	
01 2212 231 002 000	Staff Dev Retire	250.00	0.00	0.00	0.00	250.00	0.00	250.00	
01 2212 330 001 000	Purch Prof Ser Secon	1,500.00	40.00	900.00	60.00	600.00	0.00	600.00	

Expenditure Report by Op. Unit/Function

		General Fund						
Account Number	Account Description	Revised Budget	During Month	Expenditures to Date	% of Budget	Balance at EOM	Encumbrances	Unencumbered Balance
01 2212 330 002 000	Purch Prof Ser Elem	5,000.00	0.00	360.00	7.20	4,640.00	0.00	4,640.00
01 2212 580 001 000	Travel Secon	1,500.00	67.20	3,019.98	201.33	(1,519.98)	0.00	(1,519.98)
01 2212 580 002 000	Travel Elem	1,500.00	0.00	0.00	0.00	1,500.00	0.00	1,500.00
01 2212 610 001 000	Supplies Secon	2,000.00	0.00	132.50	6.63	1,867.50	0.00	1,867.50
01 2212 610 002 000	Supplies Elem	2,000.00	0.00	132.50	6.63	1,867.50	0.00	1,867.50
01 2212 810 001 000	Dues And Fees Secon	2,000.00	0.00	240.00	12.00	1,760.00	0.00	1,760.00
01 2212 810 002 000	Dues And Fees Elem	2,000.00	0.00	0.00	0.00	2,000.00	0.00	2,000.00
2212 STAFF		<u>25,000.00</u>	<u>107.20</u>	<u>4,784.98</u>	<u>19.14</u>	<u>20,215.02</u>	<u>0.00</u>	<u>20,215.02</u>
01 2214 111 000 000	SALARIES TEACHERS/PROFESSIONAL STAFF	5,100.00	0.00	0.00	0.00	5,100.00	0.00	5,100.00
01 2214 221 000 000	FICA TEACHERS/ADMIN	650.00	0.00	0.00	0.00	650.00	0.00	650.00
01 2214 231 000 000	RETIREMENT TEACHERS/ADMINS	650.00	0.00	0.00	0.00	650.00	0.00	650.00
01 2214 580 001 000	TRAVEL	150.00	0.00	0.00	0.00	150.00	0.00	150.00
01 2214 580 002 000	TRAVEL	150.00	0.00	0.00	0.00	150.00	0.00	150.00
01 2214 610 001 000	GENERAL SUPPLIES	375.00	0.00	0.00	0.00	375.00	0.00	375.00
01 2214 610 002 000	GENERAL SUPPLIES	375.00	0.00	0.00	0.00	375.00	0.00	375.00
01 2214 810 001 000	DUES AND FEES	1,425.00	0.00	0.00	0.00	1,425.00	0.00	1,425.00
01 2214 810 002 000	DUES AND FEES	1,425.00	0.00	0.00	0.00	1,425.00	0.00	1,425.00
2214 IMPLEMENTATION OF STANDARDS		<u>10,300.00</u>	<u>0.00</u>	<u>0.00</u>	<u>0.00</u>	<u>10,300.00</u>	<u>0.00</u>	<u>10,300.00</u>
01 2220 111 001 000	SALARIES TEACHERS LIBRARIAN SECON.	24,187.50	2,906.25	23,325.00	96.43	862.50	0.00	862.50
01 2220 111 002 000	SALARIES TEACHERS LIBRARIAN ELEM.	24,187.50	2,906.25	23,325.00	96.43	862.50	0.00	862.50
01 2220 211 001 000	Health Ins Secon	14,000.00	859.68	6,877.89	49.13	7,122.11	0.00	7,122.11
01 2220 211 002 000	Health Ins Elem	14,000.00	859.68	6,877.89	49.13	7,122.11	0.00	7,122.11
01 2220 221 001 000	Fica Secon	2,000.00	220.50	1,769.72	88.49	230.28	0.00	230.28
01 2220 221 002 000	Fica Elem	2,000.00	220.50	1,769.72	88.49	230.28	0.00	230.28
01 2220 231 001 000	Retire Secon	2,500.00	287.07	2,303.97	92.16	196.03	0.00	196.03
01 2220 231 002 000	Retire Elem	2,500.00	287.07	2,303.97	92.16	196.03	0.00	196.03
01 2220 320 001 000	Purchased Ser Secon	500.00	0.00	40.00	8.00	460.00	0.00	460.00
01 2220 320 002 000	Purchased Ser Elem	500.00	0.00	0.00	0.00	500.00	0.00	500.00
01 2220 431 001 000	Repair Secon	150.00	0.00	0.00	0.00	150.00	0.00	150.00
01 2220 431 002 000	Repair Elem	350.00	0.00	0.00	0.00	350.00	0.00	350.00
01 2220 610 001 000	Supplies Secon	500.00	0.00	136.64	27.33	363.36	0.00	363.36
01 2220 610 002 000	Supplies Elem	600.00	0.00	465.73	77.62	134.27	0.00	134.27
01 2220 640 001 000	Library Books Secon	4,500.00	334.81	2,146.40	47.70	2,353.60	0.00	2,353.60
01 2220 640 002 000	Library Books Elem	2,250.00	223.56	1,648.04	73.25	601.96	0.00	601.96
01 2220 641 000 000	EBOOKS	500.00	0.00	0.00	0.00	500.00	0.00	500.00
01 2220 641 001 000	Digital Mat./EBOOKS	250.00	0.00	0.00	0.00	250.00	0.00	250.00
01 2220 641 002 000	Digital Mat./EBOOKS	250.00	0.00	0.00	0.00	250.00	0.00	250.00
01 2220 643 001 000	WEB/CLOUD BASED SOFTWARE	0.00	0.00	0.00	0.00	0.00	0.00	0.00
01 2220 733 001 000	Equipment Secon	600.00	0.00	0.00	0.00	600.00	0.00	600.00
01 2220 733 002 000	Equipment Elem	600.00	0.00	0.00	0.00	600.00	0.00	600.00
01 2220 735 001 000	Computer Software	3,800.00	0.00	592.50	15.59	3,207.50	0.00	3,207.50
01 2220 735 002 000	Elem Software	2,500.00	0.00	592.50	23.70	1,907.50	0.00	1,907.50
01 2220 890 001 000	Other Mis Exp Secon	40.00	0.00	0.00	0.00	40.00	0.00	40.00
01 2220 890 002 000	Other Misc Exp Elem	100.00	0.00	0.00	0.00	100.00	0.00	100.00
2220 LIBRARY/MEDIA SERVICES		<u>103,365.00</u>	<u>9,105.37</u>	<u>74,174.97</u>	<u>71.76</u>	<u>29,190.03</u>	<u>0.00</u>	<u>29,190.03</u>
01 2310 340 000 000	SERVICES	750.00	42.00	2,542.55	339.01	(1,792.55)	0.00	(1,792.55)
01 2310 520 000 000	INSURANCE(Property, Liability)	15,500.00	0.00	0.00	0.00	15,500.00	0.00	15,500.00
01 2310 540 000 000	Advertising & Print	7,500.00	2,498.86	5,083.19	67.78	2,416.81	0.00	2,416.81
01 2310 580 000 000	Board Travel	2,000.00	0.00	0.00	0.00	2,000.00	0.00	2,000.00
01 2310 610 000 000	Supplies	3,500.00	0.00	1,470.20	42.01	2,029.80	0.00	2,029.80
01 2310 735 000 000	Software (E-Meetings)	3,000.00	0.00	2,600.00	86.67	400.00	0.00	400.00

Expenditure Report by Op. Unit/Function

		General Fund						
Account Number	Account Description	Revised Budget	During Month	Expenditures to Date	% of Budget	Balance at EOM	Encumbrances	Unencumbered Balance
01 2310 810 000 000	Dues And Fees	12,500.00	238.34	7,061.34	56.49	5,438.66	0.00	5,438.66
01 2310 890 000 000	Other Misc Exp	2,000.00	2,527.95	2,758.55	137.93	(758.55)	0.00	(758.55)
2310 BOARD OF EDUCATION		46,750.00	5,307.15	21,515.83	46.02	25,234.17	0.00	25,234.17
01 2320 105 000 000	SUPERINTENDENT SALARY	150,380.00	12,603.70	100,829.60	67.05	49,550.40	0.00	49,550.40
01 2320 110 000 000	Clerical	23,000.00	1,755.21	15,447.13	67.16	7,552.87	0.00	7,552.87
01 2320 130 000 000	OT-NON INSTRUCTIONAL	700.00	38.21	467.34	66.76	232.66	0.00	232.66
01 2320 210 000 000	GROUP INSURANCE-NON INSTRUCTIONAL	7,500.00	548.33	4,274.30	56.99	3,225.70	0.00	3,225.70
01 2320 215 000 000	Health Ins	30,000.00	2,402.05	19,216.40	64.05	10,783.60	0.00	10,783.60
01 2320 220 000 000	FICA-NON INSTRUCTIONAL	2,000.00	132.36	1,182.17	59.11	817.83	0.00	817.83
01 2320 225 000 000	Fica	12,000.00	954.62	7,636.96	63.64	4,363.04	0.00	4,363.04
01 2320 230 000 000	RETIREMENT- NON INSTRUCTIONAL	2,500.00	177.15	1,572.00	62.88	928.00	0.00	928.00
01 2320 235 000 000	RETIREMENT SUPT.	15,000.00	1,241.13	9,929.04	66.19	5,070.96	0.00	5,070.96
01 2320 280 000 000	NON INSTRUCTIONAL HSA	1,500.00	99.82	778.10	51.87	721.90	0.00	721.90
01 2320 580 000 000	Travel	2,500.00	0.00	196.00	7.84	2,304.00	0.00	2,304.00
01 2320 610 000 000	Supplies	500.00	0.00	0.00	0.00	500.00	0.00	500.00
01 2320 735 000 000	Software-North Star	2,000.00	0.00	1,800.00	90.00	200.00	0.00	200.00
01 2320 810 000 000	Dues And Fees	1,667.00	0.00	545.00	32.69	1,122.00	0.00	1,122.00
01 2320 890 000 000	Other Misc Exp	1,000.00	0.00	0.00	0.00	1,000.00	0.00	1,000.00
2320 EXECUTIVE ADMINISTRATION-SUPT		252,247.00	19,952.58	163,874.04	64.97	88,372.96	0.00	88,372.96
01 2330 317 000 000	LEGAL SERVICES	25,000.00	0.00	1,168.50	4.67	23,831.50	0.00	23,831.50
2330 DISTRICT LEGAL SERVICES		25,000.00	0.00	1,168.50	4.67	23,831.50	0.00	23,831.50
01 2410 110 001 000	Clerical Sal Secon	56,500.00	4,360.67	39,567.87	70.03	16,932.13	0.00	16,932.13
01 2410 110 002 000	Clerical Sal Elem	52,000.00	3,492.61	32,242.66	62.01	19,757.34	0.00	19,757.34
01 2410 111 001 000	Princ Sal Secon	100,000.00	8,333.33	66,666.64	66.67	33,333.36	0.00	33,333.36
01 2410 111 002 000	Prin Sal Elem	113,500.00	9,167.83	73,342.64	64.62	40,157.36	0.00	40,157.36
01 2410 120 001 000	SUBSTITUTE OR TEMPORARY SALARIES	1,000.00	141.31	828.36	82.84	171.64	0.00	171.64
01 2410 122 001 000	STUDENT AIDE	5,000.00	0.00	0.00	0.00	5,000.00	0.00	5,000.00
01 2410 130 001 000	OT-NON INSTRUCTIONAL	2,000.00	89.16	1,388.58	69.43	611.42	0.00	611.42
01 2410 130 002 000	OT-NON INSTRUCTIONAL	2,000.00	61.86	1,147.04	57.35	852.96	0.00	852.96
01 2410 151 001 000	ADDITIONAL COMP. TEACHERS/PROF. STAFF	24,047.00	478.13	3,825.04	15.91	20,221.96	0.00	20,221.96
01 2410 151 002 000	ADDITIONAL COMP. TEACHERS/PROF. STAFF	0.00	0.00	0.00	0.00	0.00	0.00	0.00
01 2410 210 001 000	GROUP INSURANCE-NON INSTRUCTIONAL	0.00	1,284.35	10,498.38	0.00	(10,498.38)	0.00	(10,498.38)
01 2410 210 002 000	GROUP INSURANCE-NON INSTRUCTIONAL	28,047.00	1,980.68	15,845.44	56.50	12,201.56	0.00	12,201.56
01 2410 211 001 000	Health Ins Secon	28,047.00	65.70	525.60	1.87	27,521.40	0.00	27,521.40
01 2410 211 002 000	Health Ins Elem	200.00	10.00	80.00	40.00	120.00	0.00	120.00
01 2410 220 001 000	FICA-NON INSTRUCTIONAL	4,500.00	339.89	3,109.55	69.10	1,390.45	0.00	1,390.45
01 2410 220 002 000	FICA-NON INSTRUCTIONAL	4,000.00	249.55	2,375.39	59.38	1,624.61	0.00	1,624.61
01 2410 221 001 000	Fica Secon	8,100.00	674.08	5,392.64	66.58	2,707.36	0.00	2,707.36
01 2410 221 002 000	Fica Elem	10,750.00	871.53	6,972.24	64.86	3,777.76	0.00	3,777.76
01 2410 230 001 000	RETIREMENT- NON INSTRUCTIONAL	6,000.00	439.54	4,045.50	67.43	1,954.50	0.00	1,954.50
01 2410 230 002 000	RETIREMENT- NON INSTRUCTIONAL	5,500.00	351.10	3,298.16	59.97	2,201.84	0.00	2,201.84
01 2410 231 001 000	RETIREMENT ADMIN SEC.	10,500.00	870.38	6,963.04	66.31	3,536.96	0.00	3,536.96
01 2410 231 002 000	RETIREMENT ADMIN ELEM.	11,000.00	905.58	7,244.64	65.86	3,755.36	0.00	3,755.36
01 2410 280 001 000	NON INSTRUCTIONAL HSA	3,500.00	233.67	1,910.40	54.58	1,589.60	0.00	1,589.60
01 2410 280 002 000	NON INSTRUCTIONAL HSA	5,000.00	360.55	2,884.40	57.69	2,115.60	0.00	2,115.60
01 2410 281 002 000	CASH IN LIEU/HSA	28,047.00	2,403.87	19,230.96	68.57	8,816.04	0.00	8,816.04
01 2410 580 001 000	Travel Secon	500.00	0.00	0.00	0.00	500.00	0.00	500.00
01 2410 580 002 000	Travel Elem	500.00	0.00	0.00	0.00	500.00	0.00	500.00

		General Fund						
Account Number	Account Description	Revised Budget	During Month	Expenditures to Date	% of Budget	Balance at EOM	Encumbrances	Unencumbered Balance
01 2410 610 001 000	Supplies Secon	1,150.00	0.00	0.00	0.00	1,150.00	0.00	1,150.00
01 2410 610 002 000	Supplies Elem	1,000.00	0.00	0.00	0.00	1,000.00	0.00	1,000.00
01 2410 733 001 000	Equipment Secon	50.00	0.00	0.00	0.00	50.00	0.00	50.00
01 2410 733 002 000	Equipment Elem	50.00	0.00	0.00	0.00	50.00	0.00	50.00
01 2410 810 001 000	Dues And Fees Secon	500.00	0.00	79.99	16.00	420.01	0.00	420.01
01 2410 810 002 000	Dues And Fees Elem	500.00	0.00	60.00	12.00	440.00	0.00	440.00
01 2410 890 001 000	Other Misc Exp Secon	500.00	0.00	0.00	0.00	500.00	0.00	500.00
01 2410 890 002 000	Other Misc Exp Elem	500.00	0.00	0.00	0.00	500.00	0.00	500.00
2410	OFFICE OF THE PRINCIPAL	514,488.00	37,165.37	309,525.16	60.16	204,962.84	0.00	204,962.84
01 2510 110 000 000	Clerical Salary	81,150.00	6,188.29	53,984.70	66.52	27,165.30	0.00	27,165.30
01 2510 130 000 000	OT-NON INSTRUCTIONAL	500.00	0.00	482.10	96.42	17.90	0.00	17.90
01 2510 150 000 000	ADDITIONAL COMP. NON INSTRUCTIONAL STAFF	11,000.00	848.31	6,786.48	61.70	4,213.52	0.00	4,213.52
01 2510 210 000 000	Health Ins	4,500.00	410.63	3,710.92	82.46	789.08	0.00	789.08
01 2510 220 000 000	Fica	6,750.00	511.86	4,466.99	66.18	2,283.01	0.00	2,283.01
01 2510 230 000 000	Retirement	8,100.00	611.26	5,380.09	66.42	2,719.91	0.00	2,719.91
01 2510 280 000 000	CASH IN LIEU/HSA	0.00	0.00	0.00	0.00	0.00	0.00	0.00
01 2510 293 000 000	Workman's Comp	40,000.00	0.00	0.00	0.00	40,000.00	0.00	40,000.00
01 2510 315 000 000	ACCOUNTING & AUDITING SERVICES	13,000.00	0.00	13,492.00	103.78	(492.00)	0.00	(492.00)
01 2510 382 001 000	Telephone Secon	6,000.00	278.79	2,867.41	47.79	3,132.59	0.00	3,132.59
01 2510 382 002 000	Telephone Elem	6,000.00	278.77	2,867.25	47.79	3,132.75	0.00	3,132.75
01 2510 431 000 000	Repair Maint Service	1,000.00	0.00	0.00	0.00	1,000.00	0.00	1,000.00
01 2510 443 000 000	Rental And Leases	2,000.00	0.00	1,840.00	92.00	160.00	0.00	160.00
01 2510 520 000 000	INSURANCE-WORKMAN'S COMP	0.00	0.00	0.00	0.00	0.00	0.00	0.00
01 2510 531 000 000	POSTAGE	6,000.00	204.87	497.08	8.28	5,502.92	0.00	5,502.92
01 2510 580 000 000	Travel	550.00	0.00	0.00	0.00	550.00	0.00	550.00
01 2510 610 000 000	Supplies	2,000.00	0.00	320.89	16.04	1,679.11	0.00	1,679.11
01 2510 733 000 000	Equipment	1,000.00	0.00	0.00	0.00	1,000.00	0.00	1,000.00
01 2510 734 000 000	Computer Hardware	1,000.00	0.00	0.00	0.00	1,000.00	0.00	1,000.00
01 2510 735 000 000	Computer Software	11,000.00	0.00	0.00	0.00	11,000.00	0.00	11,000.00
01 2510 810 000 000	REGISTRATION	250.00	0.00	40.00	16.00	210.00	0.00	210.00
01 2510 890 000 000	Other Misc Exp	250.00	0.00	0.00	0.00	250.00	0.00	250.00
2510	CLERICAL	202,050.00	9,332.78	96,735.91	47.88	105,314.09	0.00	105,314.09
01 2580 112 000 000	Tech Support Aides	6,000.00	0.00	1,038.88	17.31	4,961.12	0.00	4,961.12
01 2580 114 000 000	Tech Support Salary	80,000.00	6,250.00	54,687.20	68.36	25,312.80	0.00	25,312.80
01 2580 214 000 000	Tech Support Health Ins	1,000.00	34.57	301.28	30.13	698.72	0.00	698.72
01 2580 224 000 000	Tech Support Fica	6,500.00	477.51	4,178.15	64.28	2,321.85	0.00	2,321.85
01 2580 234 000 000	RETIREMENT-TECH	8,000.00	617.36	5,401.88	67.52	2,598.12	0.00	2,598.12
01 2580 432 000 000	TECH REPAIRS/MAINT.	2,500.00	0.00	0.00	0.00	2,500.00	0.00	2,500.00
01 2580 432 001 000	TECH REPAIRS & MAINTENANCE	1,000.00	0.00	1,150.00	115.00	(150.00)	0.00	(150.00)
01 2580 432 002 000	TECH REPAIRS & MAINTENANCE	1,000.00	0.00	1,150.00	115.00	(150.00)	0.00	(150.00)
01 2580 580 000 000	Tech Support Travel	500.00	0.00	0.00	0.00	500.00	0.00	500.00
01 2580 650 001 000	Computer Supplies	5,000.00	0.00	1,177.85	23.56	3,822.15	0.00	3,822.15
01 2580 650 002 000	Computer Supplies	5,000.00	0.00	704.61	14.09	4,295.39	0.00	4,295.39
01 2580 735 001 000	TECHNOLOGY SOFTWARE	10,000.00	0.00	0.00	0.00	10,000.00	0.00	10,000.00
01 2580 810 000 000	REGISTRATION	500.00	0.00	40.00	8.00	460.00	0.00	460.00
2580	Administrative Tech Services	127,000.00	7,379.44	69,829.85	54.98	57,170.15	0.00	57,170.15
01 2610 110 001 000	Cust Sal Secon	104,000.00	7,707.66	66,701.15	64.14	37,298.85	0.00	37,298.85
01 2610 110 002 000	Cust Sal Elem	78,000.00	5,811.00	54,081.19	69.33	23,918.81	0.00	23,918.81
01 2610 123 001 000	Sub/Summer Sal Secon	20,500.00	208.62	2,529.94	12.34	17,970.06	0.00	17,970.06
01 2610 123 002 000	Sub/Summer Sal Elem	19,500.00	0.00	1,196.84	6.14	18,303.16	0.00	18,303.16
01 2610 130 001 000	OT-NON INSTRUCTIONAL	1,500.00	0.00	28.13	1.88	1,471.87	0.00	1,471.87
01 2610 130 002 000	OT-NON INSTRUCTIONAL	1,500.00	60.90	1,867.23	124.48	(367.23)	0.00	(367.23)
01 2610 210 001 000	Health Ins Secon	47,500.00	2,098.75	17,069.85	35.94	30,430.15	0.00	30,430.15

Expenditure Report by Op. Unit/Function

		General Fund						
Account Number	Account Description	Revised Budget	During Month	Expenditures to Date	% of Budget	Balance at EOM	Encumbrances	Unencumbered Balance
01 2610 210 002 000	Health Ins Elem	32,000.00	2,123.07	18,418.08	57.56	13,581.92	0.00	13,581.92
01 2610 220 001 000	Fica Secon	9,750.00	579.35	5,031.10	51.60	4,718.90	0.00	4,718.90
01 2610 220 002 000	Fica Elem	5,700.00	415.43	3,959.53	69.47	1,740.47	0.00	1,740.47
01 2610 223 001 000	FICA-SUB SUBS	1,500.00	0.00	40.04	2.67	1,459.96	0.00	1,459.96
01 2610 223 002 000	FICA-SUB SUBS	1,250.00	0.00	40.03	3.20	1,209.97	0.00	1,209.97
01 2610 230 001 000	Retirement Secon	12,500.00	761.34	6,591.36	52.73	5,908.64	0.00	5,908.64
01 2610 230 002 000	Retirement Elem	7,500.00	558.52	5,384.36	71.79	2,115.64	0.00	2,115.64
01 2610 233 001 000	RETIREMENT-SUBS	50.00	0.00	0.00	0.00	50.00	0.00	50.00
01 2610 280 002 000	CASH IN LIEU NON INSTR/HSA	5,000.00	268.50	2,230.57	44.61	2,769.43	0.00	2,769.43
01 2610 410 001 000	Water Sewer Secon	4,000.00	373.89	2,950.40	73.76	1,049.60	0.00	1,049.60
01 2610 410 002 000	Water Sewer Elem	4,000.00	373.88	2,950.31	73.76	1,049.69	0.00	1,049.69
01 2610 520 001 000	INSURANCE(Property, Liability)	30,000.00	0.00	0.00	0.00	30,000.00	0.00	30,000.00
01 2610 520 002 000	INSURANCE(Property, Liability)	30,000.00	0.00	0.00	0.00	30,000.00	0.00	30,000.00
01 2610 610 001 000	Supplies Secon	17,500.00	615.23	9,257.82	52.90	8,242.18	0.00	8,242.18
01 2610 610 002 000	Supplies Elem	17,500.00	615.23	9,264.76	52.94	8,235.24	0.00	8,235.24
01 2610 621 001 000	Fuel Secon	55,000.00	5,024.44	37,378.44	67.96	17,621.56	0.00	17,621.56
01 2610 621 002 000	Fuel Elem	55,000.00	5,024.41	37,113.55	67.48	17,886.45	0.00	17,886.45
2610 CUSTODIAL		560,750.00	32,620.22	284,084.68	50.66	276,665.32	0.00	276,665.32
01 2620 110 000 000	Maintenance Sal	52,250.00	3,032.02	26,005.16	49.77	26,244.84	0.00	26,244.84
01 2620 210 000 000	Health Ins	5,500.00	2.40	19.20	0.35	5,480.80	0.00	5,480.80
01 2620 220 000 000	Fica	4,000.00	231.69	1,987.31	49.68	2,012.69	0.00	2,012.69
01 2620 230 000 000	Retirement	6,000.00	299.50	2,568.76	42.81	3,431.24	0.00	3,431.24
01 2620 420 001 000	CLEANING SERVICES/TRASH	6,500.00	490.50	3,924.00	60.37	2,576.00	0.00	2,576.00
01 2620 420 002 000	CLEANING SERVICES/TRASH	6,500.00	490.50	3,924.00	60.37	2,576.00	0.00	2,576.00
01 2620 431 001 000	Con/ser Repair Secon	45,000.00	340.93	18,103.60	40.23	26,896.40	0.00	26,896.40
01 2620 431 002 000	Cont/ser Repair Elem	55,000.00	250.92	4,533.25	8.24	50,466.75	0.00	50,466.75
01 2620 490 001 000	Other Purchased Property Services	0.00	0.00	166.50	0.00	(166.50)	0.00	(166.50)
01 2620 490 002 000	Other Purchased Property Services	0.00	0.00	166.50	0.00	(166.50)	0.00	(166.50)
01 2620 520 001 000	PROPERTY INS.	0.00	0.00	0.00	0.00	0.00	0.00	0.00
01 2620 520 002 000	PROPERTY INS.	0.00	0.00	0.00	0.00	0.00	0.00	0.00
01 2620 610 001 000	GENERAL SUPPLIES	20,000.00	2,166.48	10,269.40	51.35	9,730.60	0.00	9,730.60
01 2620 610 002 000	GENERAL SUPPLIES	20,000.00	1,658.85	4,438.06	22.19	15,561.94	0.00	15,561.94
01 2620 720 001 000	BUILDINGS IMPROVEMENT	0.00	0.00	0.00	0.00	0.00	0.00	0.00
01 2620 720 002 000	BUILDINGS IMPROVEMENT	0.00	0.00	0.00	0.00	0.00	0.00	0.00
01 2620 733 001 000	Equipment Secon	2,000.00	0.00	0.00	0.00	2,000.00	0.00	2,000.00
01 2620 733 002 000	Equipment Elem	2,000.00	0.00	0.00	0.00	2,000.00	0.00	2,000.00
01 2620 890 001 000	Other Exp Secon	200.00	0.00	36.00	18.00	164.00	0.00	164.00
01 2620 890 002 000	Other Exp Elem	200.00	0.00	36.00	18.00	164.00	0.00	164.00
2620 MAINTENANCE		225,150.00	8,963.79	76,177.74	33.83	148,972.26	0.00	148,972.26
01 2710 110 000 000	Transp Salaries	155,000.00	13,165.78	106,658.80	68.81	48,341.20	0.00	48,341.20
01 2710 123 000 000	SUB SALARIES	10,000.00	1,371.84	10,117.32	101.17	(117.32)	0.00	(117.32)
01 2710 210 000 000	Health Ins	8,000.00	692.26	4,945.00	61.81	3,055.00	0.00	3,055.00
01 2710 220 000 000	Fica	12,750.00	997.61	8,088.78	63.44	4,661.22	0.00	4,661.22
01 2710 223 000 000	FICA-SUB SUBS	1,550.00	104.90	773.44	49.90	776.56	0.00	776.56
01 2710 230 000 000	Retirement	10,000.00	820.65	6,556.14	65.56	3,443.86	0.00	3,443.86
01 2710 233 000 000	RETIREMENT-SUBS	200.00	79.05	643.66	321.83	(443.66)	0.00	(443.66)
01 2710 330 000 000	TESTING	2,000.00	0.00	1,110.00	55.50	890.00	0.00	890.00
01 2710 334 000 000	MILEAGE PAID-CONTRACTED	500.00	0.00	0.00	0.00	500.00	0.00	500.00
01 2710 340 000 000	Purch Ser(physicals)	2,500.00	0.00	1,169.00	46.76	1,331.00	0.00	1,331.00
01 2710 431 000 000	REPAIRS & MAINT.	25,000.00	0.00	0.00	0.00	25,000.00	0.00	25,000.00
01 2710 442 000 000	LEASE VEHICLES	6,000.00	0.00	0.00	0.00	6,000.00	0.00	6,000.00
01 2710 520 000 000	INSURANCE(Property, Liability)	20,000.00	0.00	0.00	0.00	20,000.00	0.00	20,000.00
01 2710 610 000 000	Tires And Parts	18,000.00	304.01	5,731.48	31.84	12,268.52	0.00	12,268.52
01 2710 626 000 000	Gas And Oil	54,000.00	4,157.77	30,936.19	57.29	23,063.81	0.00	23,063.81

Expenditure Report by Op. Unit/Function

Account Number		Account Description	Revised Budget	During Month	Expenditures to Date	% of Budget	Balance at EOM	Encumbrances	Unencumbered Balance
6403	IDEA PART B-SCHOOL AGE		0.00	0.00	0.00	0.00	0.00	0.00	0.00
01 6406 111 000 000	BASE 3-4 SPED INSTR		3,500.00	0.00	0.00	0.00	3,500.00	0.00	3,500.00
01 6406 211 000 000	BASE 3-4 SPED HEALTH		1,051.00	0.00	0.00	0.00	1,051.00	0.00	1,051.00
01 6406 221 000 000	BASE 3-4 SPED FICA		188.00	0.00	0.00	0.00	188.00	0.00	188.00
01 6406 231 000 000	BASE 3-4 SPED RETIR		244.00	0.00	0.00	0.00	244.00	0.00	244.00
01 6406 320 000 000	PROFESSIONAL ED SERVICES		2,529.00	0.00	0.00	0.00	2,529.00	0.00	2,529.00
6406	IDEA PRESCHOOL: 3-4		7,512.00	0.00	0.00	0.00	7,512.00	0.00	7,512.00
01 6408 591 002 000	SPED IDEA PRE-K		111,769.00	0.00	0.00	0.00	111,769.00	0.00	111,769.00
6408	IDEA Part B (611) Base & EP 0-21		111,769.00	0.00	0.00	0.00	111,769.00	0.00	111,769.00
01 6700 111 000 000	Vocational Wages		2,400.00	0.00	0.00	0.00	2,400.00	0.00	2,400.00
01 6700 211 000 000	Vocational Health		303.00	0.00	0.00	0.00	303.00	0.00	303.00
01 6700 221 000 000	Vocational FICA		183.00	0.00	0.00	0.00	183.00	0.00	183.00
01 6700 231 000 000	Vocational Retire		238.00	0.00	0.00	0.00	238.00	0.00	238.00
6700	VOCATIONAL		3,124.00	0.00	0.00	0.00	3,124.00	0.00	3,124.00
01 6992 111 000 000	REAP Salary		32,000.00	0.00	2,472.50	7.73	29,527.50	0.00	29,527.50
01 6992 211 000 000	REAP Health		11,500.00	0.00	905.23	7.87	10,594.77	0.00	10,594.77
01 6992 221 000 000	REAP Fica		2,500.00	0.00	175.29	7.01	2,324.71	0.00	2,324.71
01 6992 231 000 000	REAP Retirement		3,500.00	0.00	244.23	6.98	3,255.77	0.00	3,255.77
01 6992 281 000 000	TEACHERS/PRINCIPALS HSA		1,500.00	0.00	164.45	10.96	1,335.55	0.00	1,335.55
6992	REAP		51,000.00	0.00	3,961.70	7.77	47,038.30	0.00	47,038.30
01 6998 643 001 000	WEB/CLOUD BASED SOFTWARE		25,000.00	0.00	0.00	0.00	25,000.00	0.00	25,000.00
6998	ESSER III		25,000.00	0.00	0.00	0.00	25,000.00	0.00	25,000.00
01 8000 912 000 000	Lunch Fund		50,000.00	0.00	37,000.00	74.00	13,000.00	0.00	13,000.00
01 8000 913 001 000	Activity Transfer		30,000.00	0.00	0.00	0.00	30,000.00	0.00	30,000.00
8000	TRANSFERS (OUTGOING)		80,000.00	0.00	37,000.00	46.25	43,000.00	0.00	43,000.00
000	DISTRICT WIDE		8,682,225.00	617,968.29	4,883,347.66	56.25	3,798,877.34	0.00	3,798,877.34
01 1100 610 002 001	Grade 1 Materials		400.00	0.00	113.51	28.38	286.49	0.00	286.49
01 1100 640 002 001	Classroom Periodical		1,800.00	0.00	0.00	0.00	1,800.00	0.00	1,800.00
1100	SALARIES		2,200.00	0.00	113.51	5.16	2,086.49	0.00	2,086.49
001	FIRST GRADE		2,200.00	0.00	113.51	5.16	2,086.49	0.00	2,086.49
01 1100 610 002 002	Grade 2 Materials		400.00	0.00	1,895.68	473.92	(1,495.68)	0.00	(1,495.68)
01 1100 640 002 002	Classroom Periodical		1,750.00	0.00	171.31	9.79	1,578.69	0.00	1,578.69
1100	SALARIES		2,150.00	0.00	2,066.99	96.14	83.01	0.00	83.01
002	SECOND GRADE		2,150.00	0.00	2,066.99	96.14	83.01	0.00	83.01
01 1100 610 002 003	Grade 3 Materials		400.00	0.00	40.00	10.00	360.00	0.00	360.00
01 1100 640 002 003	Classroom Periodical		1,550.00	0.00	238.12	15.36	1,311.88	0.00	1,311.88
1100	SALARIES		1,950.00	0.00	278.12	14.26	1,671.88	0.00	1,671.88
003	THIRD GRADE		1,950.00	0.00	278.12	14.26	1,671.88	0.00	1,671.88
01 1100 610 002 004	Grade 4 Materials		400.00	0.00	0.00	0.00	400.00	0.00	400.00
01 1100 640 002 004	Classroom Periodical		650.00	0.00	335.72	51.65	314.28	0.00	314.28
1100	SALARIES		1,050.00	0.00	335.72	31.97	714.28	0.00	714.28
004	FOURTH GRADE		1,050.00	0.00	335.72	31.97	714.28	0.00	714.28
01 1100 610 002 005	Grade 5 Materials		400.00	0.00	0.00	0.00	400.00	0.00	400.00
01 1100 640 002 005	Classroom Periodical		550.00	0.00	344.66	62.67	205.34	0.00	205.34
1100	SALARIES		950.00	0.00	344.66	36.28	605.34	0.00	605.34
005	FIFTH GRADE		950.00	0.00	344.66	36.28	605.34	0.00	605.34
01 1100 610 002 006	Grade 6 Materials		400.00	0.00	344.66	86.17	55.34	0.00	55.34
01 1100 640 002 006	Classroom Periodical		300.00	0.00	0.00	0.00	300.00	0.00	300.00

Expenditure Report by Op. Unit/Function

Account Number		Account Description	Revised Budget	During Month	Expenditures to Date	% of Budget	Balance at EOM	Encumbrances	Unencumbered Balance
1100	SALARIES		700.00	0.00	344.66	49.24	355.34	0.00	355.34
006	SIXTH GRADE		700.00	0.00	344.66	49.24	355.34	0.00	355.34
01 1100 610 002 007	Kingrt Materials		300.00	0.00	0.00	0.00	300.00	0.00	300.00
01 1100 640 002 007	Classroom Periodical		800.00	0.00	0.00	0.00	800.00	0.00	800.00
1100	SALARIES		1,100.00	0.00	0.00	0.00	1,100.00	0.00	1,100.00
007	Kindergarten		1,100.00	0.00	0.00	0.00	1,100.00	0.00	1,100.00
01 1100 610 002 017	Elem Art Materials		501.00	0.00	0.00	0.00	501.00	0.00	501.00
1100	SALARIES		501.00	0.00	0.00	0.00	501.00	0.00	501.00
017	ELEM. ART		501.00	0.00	0.00	0.00	501.00	0.00	501.00
01 1100 610 001 018	Music Materials		1,000.00	159.92	1,935.47	193.55	(935.47)	0.00	(935.47)
01 1100 610 002 018	Music Materials		727.00	0.00	52.31	7.20	674.69	0.00	674.69
01 1100 733 001 018	Music Equipment		500.00	0.00	0.00	0.00	500.00	0.00	500.00
01 1100 733 002 018	Music Equipment		500.00	0.00	0.00	0.00	500.00	0.00	500.00
01 1100 810 001 018	FEES		831.00	0.00	744.00	89.53	87.00	0.00	87.00
1100	SALARIES		3,558.00	159.92	2,731.78	76.78	826.22	0.00	826.22
018	MUSIC		3,558.00	159.92	2,731.78	76.78	826.22	0.00	826.22
01 1100 610 002 019	Elem Pe Materials		200.00	0.00	0.00	0.00	200.00	0.00	200.00
01 1100 733 002 019	Equipment		300.00	0.00	0.00	0.00	300.00	0.00	300.00
1100	SALARIES		500.00	0.00	0.00	0.00	500.00	0.00	500.00
019	ELEM. PE		500.00	0.00	0.00	0.00	500.00	0.00	500.00
01 1100 610 001 020	Lang Arts Materials		500.00	0.00	8.96	1.79	491.04	0.00	491.04
01 1100 640 001 020	Classroom Periodical		600.00	0.00	326.67	54.45	273.33	0.00	273.33
01 1100 735 001 020	Computer Software		200.00	0.00	0.00	0.00	200.00	0.00	200.00
01 1100 810 001 020	Student Registration		900.00	0.00	0.00	0.00	900.00	0.00	900.00
1100	SALARIES		2,200.00	0.00	335.63	15.26	1,864.37	0.00	1,864.37
020	LANGUAGE ARTS		2,200.00	0.00	335.63	15.26	1,864.37	0.00	1,864.37
01 1100 610 001 021	Math Materials		200.00	0.00	516.82	258.41	(316.82)	0.00	(316.82)
1100	SALARIES		200.00	0.00	516.82	258.41	(316.82)	0.00	(316.82)
021	MATH		200.00	0.00	516.82	258.41	(316.82)	0.00	(316.82)
01 1100 431 001 022	REPAIRS & MAINTENANCE - Contracted		750.00	0.00	0.00	0.00	750.00	0.00	750.00
01 1100 610 001 022	Materials		5,000.00	0.00	420.02	8.40	4,579.98	0.00	4,579.98
01 1100 640 001 022	Classroom Periodical		350.00	0.00	340.99	97.43	9.01	0.00	9.01
01 1100 733 001 022	Equipment		3,000.00	0.00	0.00	0.00	3,000.00	0.00	3,000.00
01 1100 735 001 022	Computer Software		250.00	0.00	872.27	348.91	(622.27)	0.00	(622.27)
1100	SALARIES		9,350.00	0.00	1,633.28	17.47	7,716.72	0.00	7,716.72
022	SCIENCE		9,350.00	0.00	1,633.28	17.47	7,716.72	0.00	7,716.72
01 1100 610 001 023	Soc Stud Materials		150.00	0.00	5.79	3.86	144.21	0.00	144.21
01 1100 640 001 023	Classroom Periodical		320.00	0.00	0.00	0.00	320.00	0.00	320.00
1100	SALARIES		470.00	0.00	5.79	1.23	464.21	0.00	464.21
023	SOCIAL STUDIES		470.00	0.00	5.79	1.23	464.21	0.00	464.21
01 1100 431 001 025	REPAIRS & MAINTENANCE - Contracted		1,600.00	0.00	0.00	0.00	1,600.00	0.00	1,600.00
01 1100 580 001 025	Instructor Travel		1,700.00	0.00	0.00	0.00	1,700.00	0.00	1,700.00
01 1100 610 001 025	Instr Materials		4,000.00	485.07	2,539.92	63.50	1,460.08	0.00	1,460.08
01 1100 640 001 025	Expendable Wrbk		65.00	0.00	0.00	0.00	65.00	0.00	65.00
01 1100 733 001 025	Equipment Secon		125.00	0.00	0.00	0.00	125.00	0.00	125.00
01 1100 735 001 025	Comp Software Secon		500.00	0.00	0.00	0.00	500.00	0.00	500.00
01 1100 810 001 025	FEES		950.00	0.00	0.00	0.00	950.00	0.00	950.00

Expenditure Report by Op. Unit/Function

Account Number		Account Description	Revised Budget	During Month	Expenditures to Date	% of Budget	Balance at EOM	Encumbrances	Unencumbered Balance
1100	SALARIES		8,940.00	485.07	2,539.92	28.41	6,400.08	0.00	6,400.08
025	AGRICULTURE		8,940.00	485.07	2,539.92	28.41	6,400.08	0.00	6,400.08
01 1100 431 001 026	REPAIRS & MAINTENANCE - Contracted		200.00	0.00	0.00	0.00	200.00	0.00	200.00
01 1100 580 001 026	Instructor Travel		300.00	0.00	0.00	0.00	300.00	0.00	300.00
01 1100 610 001 026	Instr Materials		1,000.00	0.00	0.00	0.00	1,000.00	0.00	1,000.00
01 1100 640 001 026	Expendable Wrbk		1,000.00	0.00	0.00	0.00	1,000.00	0.00	1,000.00
01 1100 733 001 026	Equipment		100.00	0.00	0.00	0.00	100.00	0.00	100.00
01 1100 735 001 026	Comp Software		1,000.00	0.00	0.00	0.00	1,000.00	0.00	1,000.00
01 1100 810 001 026	FEES		1,400.00	0.00	399.00	28.50	1,001.00	0.00	1,001.00
1100	SALARIES		5,000.00	0.00	399.00	7.98	4,601.00	0.00	4,601.00
026	BUSINESS		5,000.00	0.00	399.00	7.98	4,601.00	0.00	4,601.00
01 1100 610 001 027	Secon Art Materials		1,800.00	0.00	504.61	28.03	1,295.39	0.00	1,295.39
1100	SALARIES		1,800.00	0.00	504.61	28.03	1,295.39	0.00	1,295.39
027	SECONDARY ART		1,800.00	0.00	504.61	28.03	1,295.39	0.00	1,295.39
01 1100 350 001 028	Other Purchased Services		0.00	0.00	0.00	0.00	0.00	0.00	0.00
01 1100 431 001 028	REPAIRS & MAINTENANCE - Contracted		2,500.00	124.00	1,964.00	78.56	536.00	0.00	536.00
01 1100 431 002 028	REPAIRS & MAINTENANCE - Contracted		500.00	0.00	0.00	0.00	500.00	0.00	500.00
01 1100 610 001 028	Instr Materials		1,000.00	1,041.27	1,427.23	142.72	(427.23)	0.00	(427.23)
01 1100 610 002 028	Instrument Materials		1,000.00	0.00	0.00	0.00	1,000.00	0.00	1,000.00
01 1100 733 001 028	Equipment		3,000.00	0.00	0.00	0.00	3,000.00	0.00	3,000.00
01 1100 733 002 028	Equipment		1,000.00	0.00	0.00	0.00	1,000.00	0.00	1,000.00
01 1100 810 001 028	Registration		500.00	0.00	235.00	47.00	265.00	0.00	265.00
01 1100 810 002 028	Student Registration		500.00	0.00	0.00	0.00	500.00	0.00	500.00
1100	SALARIES		10,000.00	1,165.27	3,626.23	36.26	6,373.77	0.00	6,373.77
028	BAND		10,000.00	1,165.27	3,626.23	36.26	6,373.77	0.00	6,373.77
01 1100 431 001 029	REPAIRS & MAINTENANCE - Contracted		500.00	0.00	0.00	0.00	500.00	0.00	500.00
01 1100 440 001 029	Secon Pe Rental		6,500.00	0.00	0.00	0.00	6,500.00	0.00	6,500.00
01 1100 610 001 029	Instr Materials		800.00	0.00	20.98	2.62	779.02	0.00	779.02
01 1100 733 001 029	Equipment		1,000.00	0.00	0.00	0.00	1,000.00	0.00	1,000.00
1100	SALARIES		8,800.00	0.00	20.98	0.24	8,779.02	0.00	8,779.02
029	SECONDARY PE		8,800.00	0.00	20.98	0.24	8,779.02	0.00	8,779.02
01 1100 610 001 030	FCS Instr Materials		500.00	0.00	0.00	0.00	500.00	0.00	500.00
1100	SALARIES		500.00	0.00	0.00	0.00	500.00	0.00	500.00
030	FCS		500.00	0.00	0.00	0.00	500.00	0.00	500.00
01 1100 431 001 031	REPAIRS & MAINTENANCE - Contracted		300.00	0.00	0.00	0.00	300.00	0.00	300.00
01 1100 580 001 031	Instructor Travel		250.00	0.00	0.00	0.00	250.00	0.00	250.00
01 1100 610 001 031	Instruc Materials		2,000.00	91.12	1,242.07	62.10	757.93	0.00	757.93
01 1100 733 001 031	Equipment		1,000.00	0.00	0.00	0.00	1,000.00	0.00	1,000.00
01 1100 735 001 031	Comp Software		300.00	0.00	0.00	0.00	300.00	0.00	300.00
01 1100 810 001 031	Instru Registration		1,080.00	0.00	0.00	0.00	1,080.00	0.00	1,080.00
1100	SALARIES		4,930.00	91.12	1,242.07	25.19	3,687.93	0.00	3,687.93
031	INDUSTRIAL ARTS		4,930.00	91.12	1,242.07	25.19	3,687.93	0.00	3,687.93
01 1100 610 001 032	Foreign Lang Mater		200.00	0.00	0.00	0.00	200.00	0.00	200.00
01 1100 640 001 032	Classroom Period		150.00	0.00	0.00	0.00	150.00	0.00	150.00
01 1100 810 001 032	REGISTRATION		50.00	90.00	90.00	180.00	(40.00)	0.00	(40.00)
1100	SALARIES		400.00	90.00	90.00	22.50	310.00	0.00	310.00

Expenditure Report by Op. Unit/Function

		General Fund						
Account Number	Account Description	Revised Budget	During Month	Expenditures to Date	% of Budget	Balance at EOM	Encumbrances	Unencumbered Balance
032	FOREIGN LANGUAGE	400.00	90.00	90.00	22.50	310.00	0.00	310.00
01 1100 610 001 033	Journalism Materials	300.00	0.00	0.00	0.00	300.00	0.00	300.00
01 1100 733 001 033	Journalism Equip	300.00	0.00	0.00	0.00	300.00	0.00	300.00
1100	SALARIES	600.00	0.00	0.00	0.00	600.00	0.00	600.00
033	JOURNALISM	600.00	0.00	0.00	0.00	600.00	0.00	600.00
01 2171 591 002 600	PT Therapy	0.00	0.00	0.00	0.00	0.00	0.00	0.00
2171	PHYSICAL THERAPY-SPED SCHOOL AGE	0.00	0.00	0.00	0.00	0.00	0.00	0.00
01 2172 591 002 600	PT SPED 3-5	0.00	0.00	0.00	0.00	0.00	0.00	0.00
2172	PHYSICAL THERAPY:SPED 3-5	0.00	0.00	0.00	0.00	0.00	0.00	0.00
600	PT Services	0.00	0.00	0.00	0.00	0.00	0.00	0.00
01 2161 320 001 601	PROFESSIONAL ED SERVICES	5,000.00	0.00	0.00	0.00	5,000.00	0.00	5,000.00
2161	OCCUPATIONAL THERAPY-SPED SCHOOL AGE	5,000.00	0.00	0.00	0.00	5,000.00	0.00	5,000.00
01 2162 591 002 601	OT SPED 3-5	0.00	0.00	0.00	0.00	0.00	0.00	0.00
2162	OCCUPATIONAL THERAPY-SPED 3-5	0.00	0.00	0.00	0.00	0.00	0.00	0.00
601	OT Services	5,000.00	0.00	0.00	0.00	5,000.00	0.00	5,000.00
01 2151 320 001 602	Speech Therapy Services	0.00	0.00	0.00	0.00	0.00	0.00	0.00
01 2151 591 001 602	Speech Therapy	40,000.00	3,749.15	34,792.52	86.98	5,207.48	0.00	5,207.48
01 2151 591 002 602	Speech Therapy Elem	160,000.00	10,871.64	100,947.70	63.09	59,052.30	0.00	59,052.30
2151	SPEECH PATH/AUDIOLOGY-SPED School Age	200,000.00	14,620.79	135,740.22	67.87	64,259.78	0.00	64,259.78
01 2152 591 002 602	PRE SCHL SPEECH (3-5)	5,000.00	1,968.53	10,439.26	208.79	(5,439.26)	0.00	(5,439.26)
2152	SPEECH PATH/AUDIOLOGY-SPED Ages 3-5	5,000.00	1,968.53	10,439.26	208.79	(5,439.26)	0.00	(5,439.26)
01 2153 591 002 602	SPEECH (0-2)	6,300.00	1,306.39	12,904.61	204.84	(6,604.61)	0.00	(6,604.61)
2153	SPEECH PATH/AUDIOLOGY-SPED Ages 0-2	6,300.00	1,306.39	12,904.61	204.84	(6,604.61)	0.00	(6,604.61)
602	Speech	211,300.00	17,895.71	159,084.09	75.29	52,215.91	0.00	52,215.91
01 1291 591 002 603	PRE SPED Supervision (3-5)	3,500.00	275.82	2,457.58	70.22	1,042.42	0.00	1,042.42
1291	SPED AGES 3-5	3,500.00	275.82	2,457.58	70.22	1,042.42	0.00	1,042.42
01 1292 591 002 603	Pre Sped Services (0-2)	3,500.00	275.82	2,457.58	70.22	1,042.42	0.00	1,042.42
1292	SPED AGES 0-2	3,500.00	275.82	2,457.58	70.22	1,042.42	0.00	1,042.42
603	Sped Super	7,000.00	551.64	4,915.16	70.22	2,084.84	0.00	2,084.84
01 1200 591 001 604	Deaf Ed	5,500.00	0.00	0.00	0.00	5,500.00	0.00	5,500.00
01 1200 591 002 604	DEAF ED	5,500.00	0.00	0.00	0.00	5,500.00	0.00	5,500.00
1200	SPEDICAL ED School Age	11,000.00	0.00	0.00	0.00	11,000.00	0.00	11,000.00
01 2151 591 001 604	ESU SERVICES-Deaf Ed Sec.	5,000.00	502.61	5,534.00	110.68	(534.00)	0.00	(534.00)
01 2151 591 002 604	Deaf Ed Sped Elem.	5,000.00	502.61	6,415.50	128.31	(1,415.50)	0.00	(1,415.50)
2151	SPEECH PATH/AUDIOLOGY-SPED School Age	10,000.00	1,005.22	11,949.50	119.50	(1,949.50)	0.00	(1,949.50)
01 2153 591 002 604	Pre Deaf Ed Services (0-2)	500.00	0.00	0.00	0.00	500.00	0.00	500.00
2153	SPEECH PATH/AUDIOLOGY-SPED Ages 0-2	500.00	0.00	0.00	0.00	500.00	0.00	500.00
604	Deaf Ed	21,500.00	1,005.22	11,949.50	55.58	9,550.50	0.00	9,550.50
01 2181 591 001 605	Vision	0.00	0.00	331.75	0.00	(331.75)	0.00	(331.75)
01 2181 591 002 605	VISION	4,750.00	438.14	3,220.94	67.81	1,529.06	0.00	1,529.06
2181	VISUALLY IMPAIRED:SPED SCHOOL AGE	4,750.00	438.14	3,552.69	74.79	1,197.31	0.00	1,197.31
605	Vision	4,750.00	438.14	3,552.69	74.79	1,197.31	0.00	1,197.31
01 2141 591 001 606	SCHOOL PSYCH	30,000.00	2,580.89	22,447.95	74.83	7,552.05	0.00	7,552.05
01 2141 591 002 606	Diagnostic Testing (School Psych)	30,000.00	2,580.89	22,447.95	74.83	7,552.05	0.00	7,552.05
2141	PSYCHOLOGICAL SERVICES: SPED SCHOOL AGE	60,000.00	5,161.78	44,895.90	74.83	15,104.10	0.00	15,104.10
01 2142 591 002 606	PSYCH SERVICES SPED 3-5	6,650.00	645.22	5,611.99	84.39	1,038.01	0.00	1,038.01

Expenditure Report by Op. Unit/Function

Account Number		Account Description	Revised Budget	During Month	Expenditures to Date	% of Budget	Balance at EOM	Encumbrances	Unencumbered Balance
2142		PSYCHOLOGICAL SERVICES: SPED 3-5	6,650.00	645.22	5,611.99	84.39	1,038.01	0.00	1,038.01
01 2143 591 002 606		PSYC SERVICES SPED 0-2	6,650.00	645.22	5,611.99	84.39	1,038.01	0.00	1,038.01
2143		PSYCHOLOGICAL SERVICES: SPED 0-2	6,650.00	645.22	5,611.99	84.39	1,038.01	0.00	1,038.01
606		D/E Psychological	73,300.00	6,452.22	56,119.88	76.56	17,180.12	0.00	17,180.12
01 2151 591 001 607		Audiology Secon	5,000.00	68.09	634.76	12.70	4,365.24	0.00	4,365.24
01 2151 591 002 607		Audiology Elem	15,000.00	68.09	634.76	4.23	14,365.24	0.00	14,365.24
2151		SPEECH PATH/AUDIOLOGY-SPED School Age	20,000.00	136.18	1,269.52	6.35	18,730.48	0.00	18,730.48
01 2152 591 002 607		AUDIOLOGY SPED 3-5	250.00	17.02	158.68	63.47	91.32	0.00	91.32
2152		SPEECH PATH/AUDIOLOGY-SPED Ages 3-5	250.00	17.02	158.68	63.47	91.32	0.00	91.32
01 2153 591 002 607		AUDIOLOGY SPED 0-2	250.00	17.02	158.68	63.47	91.32	0.00	91.32
2153		SPEECH PATH/AUDIOLOGY-SPED Ages 0-2	250.00	17.02	158.68	63.47	91.32	0.00	91.32
607		Audiology	20,500.00	170.22	1,586.88	7.74	18,913.12	0.00	18,913.12
01 1200 591 000 608		Vocational	2,500.00	116.92	1,104.07	44.16	1,395.93	0.00	1,395.93
1200		SPEDICAL ED School Age	2,500.00	116.92	1,104.07	44.16	1,395.93	0.00	1,395.93
608		VOCATIONAL	2,500.00	116.92	1,104.07	44.16	1,395.93	0.00	1,395.93
01		General	9,095,924.00	646,589.74	5,138,789.70	56.50	3,957,134.30	0.00	3,957,134.30

Account Number

Account Description

Expenditure Report by Op. Unit/Function

General Fund

	Revised Budget	During Month	Expenditures to Date	% of Budget	Balance at EOM	Encumbrances	Unencumbered Balance
Grand Total:	9,095,924.00	646,589.74	5,138,789.70	56.50	3,957,134.30	0.00	3,957,134.30

**Ravenna Public Schools
GENERAL FUND
Ending March 31st, 2025**

Beginning Balance: **\$815,007.19**

Receipts:

Tax Collection (Buffalo)	\$630,082.24
Tax Collection (Sherman)	\$11,608.53
State of NE Sped	\$155,350.00
State Apportionment	\$0.00
ALICAP WC Prem.	
Transportation	
ESU 10	\$300.00
Sale of Prop/Equip.	
Medicaid (MAC)	
State Aid	\$118,396.00
State of NE (MIPS)	
Other	\$385.92
Interest	\$133.75

Total Receipts: **\$916,256.44**

Disbursements:

Board Bills (Mar)	\$651,977.73
-------------------	--------------

\$651,977.73

Ending Balance: **\$1,079,285.90**

Cash on Hand: **\$1,079,285.90**

Outstanding checks	\$110,291.32
--------------------	--------------

Bank Balance:	\$1,189,577.22
----------------------	-----------------------

Investments: **\$1,289,868.27**

Accounted for as Follows:

General Fund

General Fund Checking	\$1,079,285.90
CD #xxx3375	\$0.00
CD # 70099 (9 mo)	\$1,289,868.27

Total Available: **\$2,369,154.17** **\$2,369,154.17**

Account Number	Account Description	Budget	Month to Date	Year to Date
8	Revenue			
01 1100 1000	District Taxes - Buffalo	3,514,679.00	23,118.55	1,686,879.54
01 1100 1100	District Taxes - Sherman	930,000.00	5,952.15	453,194.75
01 1115 1000	Carline-Buffalo	8,000.00	0.00	789.79
01 1115 1100	Carline - Sherman	2,000.00	0.00	227.04
01 1120 1000	Public Power Tax - Buffalo	100,000.00	0.00	0.00
01 1120 1100	Public Power Tax - Sherman	65,000.00	0.00	0.00
01 1125 1000	Motor Vehicle Taxes - Buffalo	210,000.00	14,560.82	120,929.80
01 1125 1100	Motor Vehicle Taxes - Sherman	40,000.00	4,240.91	22,036.35
01 1311	Tuition Individual	0.00	0.00	0.00
01 1313	Tuit Sp Ed Individ.	0.00	0.00	0.00
01 1315	DISTANCE LEARNING	0.00	0.00	7,320.00
01 1323	Tuit Sp Ed Oth Dist.	0.00	0.00	0.00
01 1410	Trans. Individual	0.00	0.00	0.00
01 1411	Trans Sp Ed Individ.	0.00	0.00	0.00
01 1421	Trans. Other Dist.	0.00	0.00	0.00
01 1423	Trans Sp Ed Oth Dist	0.00	0.00	2,357.50
01 1510	Interest On Invest.	45,000.00	133.75	8,797.51
01 1701	Bond Fund Transfer	0.00	0.00	0.00
01 1740	Fees	0.00	0.00	0.00
01 1742	PostSecondary Fees	0.00	0.00	0.00
01 1790	Driver's Ed	0.00	0.00	0.00
01 1800	KEARNEY FOUND YC	0.00	0.00	0.00
01 1900	AUTISM ACTION PARTNERSHIP	0.00	0.00	0.00
01 1910	RENTAL OF SCHOOL EQUIPMENT & FACILITIES	1,000.00	150.00	1,050.00
01 1911	Local License Fees	2,000.00	150.00	2,200.00
01 1920	CONTRIBUTIONS & DONATIONS	0.00	0.00	0.00
01 1921	Police Court Fines	0.00	0.00	0.00
01 1925	Tobacco Grant	0.00	0.00	0.00
01 1955	Postsecondary Receipts	0.00	0.00	0.00
01 2110 1000	Buffalo Co Fines-lic	25,000.00	2,311.01	13,159.24
01 2110 1100	Sherm Fines-license	5,000.00	259.51	1,582.39
01 2130 1000	Other County Receipt - Buffalo	0.00	0.00	0.00
01 2130 1100	Other County Receipts- Sherman	0.00	0.00	0.00
01 2140	Non-resident Tuition	0.00	0.00	0.00
01 2210	ESU Receipts	0.00	300.00	1,025.00
01 3110	State Aid	591,978.00	118,396.00	414,386.00
01 3120	Spec. Ed Programs	900,000.00	155,350.00	579,267.00
01 3125	Special Ed Transpor.	10,000.00	0.00	0.00
01 3130 1000	Homestead Exemption - Buffalo	0.00	12,854.34	12,854.34
01 3130 1100	Sherm Homestead Ex	0.00	1,155.96	1,155.96
01 3131	PROPERTY TAX CREDIT	0.00	577,087.52	752,648.71
01 3134	PERSONAL PROPERTY TAX CREDIT-RR & PSE	0.00	0.00	0.00
01 3170	State Vocational	0.00	0.00	0.00
01 3180 1000	Pro-rata Motor Veh.Buffalo	8,000.00	0.00	3,469.14
01 3180 1100	Sher Pro Rat Moto V	2,000.00	0.00	747.03
01 3400	State Apportionment	60,000.00	0.00	129,018.60
01 3500	Other State Categorical Programs	0.00	0.00	0.00

Account Number	Account Description	Budget	Month to Date	Year to Date
01 3512	DIST ED INCENTIVE	0.00	0.00	0.00
01 3535	High Abilt Learners	4,500.00	0.00	4,166.00
01 3550	School Tech Fund	0.00	0.00	0.00
01 3551	Career Education (CTE)	4,000.00	0.00	0.00
01 3552 000	School Safety & Security Act	0.00	0.00	0.00
01 3570	Teacher Evaluation	0.00	0.00	0.00
01 3599	Other State Categorical Programs	0.00	0.00	10,394.81
01 3990	Other State Funds	0.00	0.00	0.00
01 4100	Title 1 Carry Over	0.00	0.00	0.00
01 4105	UNIVERSAL SERVICE FUND (E-RATE)	0.00	0.00	0.00
01 4310 000	Title V, Part B, ESSA-REAP	30,000.00	0.00	39,350.00
01 4311	Title VI Past Year	0.00	0.00	0.00
01 4312	Title VI Current	0.00	0.00	0.00
01 4315	Title V	0.00	0.00	0.00
01 4325	Title IIA Class Size Reduction	0.00	0.00	0.00
01 4401	IDEA PRESCHOOL	0.00	0.00	0.00
01 4402	Preschool Travel	0.00	0.00	0.00
01 4403	Spec Ed Medicaid	0.00	0.00	0.00
01 4421	IDEA Part-B Base/EP 0-21	0.00	0.00	0.00
01 4422	IDEA Preschool ARP-Base 0-21	0.00	0.00	0.00
01 4423	IDEA Part B ARP Prop. Share	0.00	0.00	0.00
01 4505	Title 1 Current	80,000.00	0.00	67,302.00
01 4506	Title 1 NCLB	0.00	0.00	0.00
01 4509	TITLE II, PART A NCLB TCHR QULTY GRANTS	0.00	0.00	16,100.00
01 4511	REAP GRANT	0.00	0.00	0.00
01 4512	IDEA Base	0.00	0.00	0.00
01 4516	IDEA Pre-school Handicapp	1,000.00	0.00	2,683.00
01 4518	IDEA Part B (611) Base & EP	100,000.00	0.00	111,769.00
01 4519	IDEA E-P	0.00	0.00	0.00
01 4521	IDEA Part B Proportionate Share	0.00	0.00	2,059.00
01 4524	OTHER FEDERAL NON-CATEGORICAL RECEIPTS	0.00	0.00	0.00
01 4525	Fed. Vocational	0.00	0.00	0.00
01 4530	Other Federal Categ. Receipts	0.00	0.00	0.00
01 4580	EDUCATION JOB MONEY	0.00	0.00	0.00
01 4599	ARRA STATE AID	0.00	0.00	0.00
01 4708	Medicaid in Public School (MIPS)	5,000.00	0.00	2,384.12
01 4709	Medicaid Administrative Activities	7,500.00	0.00	3,015.84
01 4900	Other Fed. Non-cat	0.00	0.00	0.00
01 4969	Title IV, Part A	0.00	0.00	10,000.00
01 4996	CARES Act	0.00	0.00	0.00
01 4997	ESSER II	0.00	0.00	0.00
01 4998	ESSER III	0.00	0.00	57,687.00
01 5200	From Other Funds	0.00	0.00	0.00
01 5300	Sale Of Prop & Equip	0.00	0.00	945.00
01 5301	Insurance Adjustment	0.00	0.00	13,223.00
01 5690	Other Non-revenue	0.00	235.92	502,653.82
01 9000	Non-program Receipts	0.00	0.00	0.00
01 9004	Interfund from QCPUF	0.00	0.00	0.00

Revenue Detail

Account Number	Account Description	Budget	Month to Date	Year to Date
01 9100	NE ST REVENUE	0.00	0.00	0.00
01 9200	Interlocal Agreement	0.00	0.00	0.00
01	General	<u>6,751,657.00</u>	<u>916,256.44</u>	<u>5,058,828.28</u>
8	Revenue	<u>6,751,657.00</u>	<u>916,256.44</u>	<u>5,058,828.28</u>

PO Number	Invoice Number	Vendor Name	Invoice Date	Amount
Account Number		Detail Description		Amount
Checking Account ID	06	Fund Number 06	Lunch	
	14535650	CASH-WA DISTRIBUTING	03/04/2025	2,331.78
06 3100 630 000		FOOD		2,304.24
06 3100 610 000		GENERAL SUPPLIES		27.54
	14543915	CASH-WA DISTRIBUTING	03/11/2025	1,173.38
06 3100 630 000		FOOD		853.52
06 3100 610 000		GENERAL SUPPLIES		319.86
	14551454	CASH-WA DISTRIBUTING	03/18/2025	508.36
06 3100 630 000		FOOD		508.36
	14559195	CASH-WA DISTRIBUTING	03/25/2025	1,184.27
06 3100 630 000		FOOD		1,184.27
	CM3789534	CASH-WA DISTRIBUTING	03/27/2025	(137.92)
06 3100 630 000		FOOD		(137.92)
	P14549573	CASH-WA DISTRIBUTING	03/14/2025	151.86
06 3100 630 000		FOOD		151.86
	P14560660	CASH-WA DISTRIBUTING	03/25/2025	119.12
06 3100 630 000		FOOD		119.12
	S14558262	CASH-WA DISTRIBUTING	03/25/2025	473.11
06 3100 630 000		FOOD		473.11
Total	CASH-WA DISTRIBUTING			5,803.96
	1204713	HILAND DAIRY CO	03/03/2025	766.26
06 3100 630 000		FOOD		766.26
	1204714	HILAND DAIRY CO	03/03/2025	(254.13)
06 3100 630 000		FOOD		(254.13)
	1204828	HILAND DAIRY CO	03/10/2025	360.44
06 3100 630 000		FOOD		360.44
	1204948	HILAND DAIRY CO	03/17/2025	720.88
06 3100 630 000		FOOD		720.88
	1204949	HILAND DAIRY CO	03/17/2025	(106.45)
06 3100 630 000		FOOD		(106.45)
	1205071	HILAND DAIRY CO	03/24/2025	493.98
06 3100 630 000		FOOD		493.98
	1205193	HILAND DAIRY CO	03/31/2025	630.12
06 3100 630 000		FOOD		630.12
Total	HILAND DAIRY CO			2,611.10
	661149115	SYSCO LINCOLN	02/01/2025	14.52
06 3100 610 000		GENERAL SUPPLIES		14.52
	661209990	SYSCO LINCOLN	03/07/2025	2,154.82
06 3100 630 000		FOOD		2,115.81
06 3100 610 000		GENERAL SUPPLIES		39.01
	661220683	SYSCO LINCOLN	03/13/2025	1,538.62
06 3100 630 000		FOOD		1,421.65
06 3100 610 000		GENERAL SUPPLIES		116.97
	661232438	SYSCO LINCOLN	03/21/2025	294.10
06 3100 630 000		FOOD		294.10
	661244698	SYSCO LINCOLN	03/27/2025	2,265.94
06 3100 630 000		FOOD		2,033.92
06 3100 610 000		GENERAL SUPPLIES		232.02
Total	SYSCO LINCOLN			6,268.00
	317	University of Nebraska Lincoln, The	04/08/2025	380.00
06 3100 810 000 000		Registration		380.00
Total	University of Nebraska Lincoln, The			380.00

PO Number	Invoice Number	Vendor Name	Invoice Date	Amount
Account Number		Detail Description		
	3952518	US Foods - Grand Island	03/07/2025	1,698.04
06 3100 630 000		FOOD		<u>1,698.04</u>
Total	US Foods - Grand Island			<u>1,698.04</u>
Fund Number	06			<u>16,761.10</u>
Checking Account ID	06			<u>16,761.10</u>

Expenditure Report by Op. Unit/Function

Account Number	Account Description	Revised Budget	During Month	Expenditures to Date	% of Budget	Balance at EOM	Encumbrances	Unencumbered Balance
06	Lunch							
06 3100 610 000	GENERAL SUPPLIES	0.00	749.92	7,467.28	0.00	(7,467.28)	0.00	(7,467.28)
06 3100 630 000	FOOD	0.00	15,631.18	151,306.26	0.00	(151,306.26)	0.00	(151,306.26)
3100	FOOD SERVICES	0.00	16,381.10	158,773.54	0.00	(158,773.54)	0.00	(158,773.54)
		0.00	16,381.10	158,773.54	0.00	(158,773.54)	0.00	(158,773.54)
06 3100 110 000 000	Salary	0.00	8,647.85	76,057.11	0.00	(76,057.11)	0.00	(76,057.11)
06 3100 120 000 000	Sub Salaries	0.00	304.20	2,769.65	0.00	(2,769.65)	0.00	(2,769.65)
06 3100 130 000 000	Overtime Salaries	0.00	294.47	2,061.48	0.00	(2,061.48)	0.00	(2,061.48)
06 3100 210 000 000	Health Insurance	0.00	4,941.08	38,676.33	0.00	(38,676.33)	0.00	(38,676.33)
06 3100 220 000 000	Fica	0.00	653.80	5,760.02	0.00	(5,760.02)	0.00	(5,760.02)
06 3100 230 000 000	Retirement	0.00	694.10	6,034.74	0.00	(6,034.74)	0.00	(6,034.74)
06 3100 431 000 000	Repair	0.00	0.00	1,607.60	0.00	(1,607.60)	0.00	(1,607.60)
06 3100 733 000 000	Equipment	0.00	0.00	17,245.00	0.00	(17,245.00)	0.00	(17,245.00)
06 3100 810 000 000	Registration	0.00	380.00	380.00	0.00	(380.00)	0.00	(380.00)
06 3100 890 000 000	Other Supplies/Misc	0.00	0.00	87.60	0.00	(87.60)	0.00	(87.60)
3100	FOOD SERVICES	0.00	15,915.50	150,679.53	0.00	(150,679.53)	0.00	(150,679.53)
000	DISTRICT WIDE	0.00	15,915.50	150,679.53	0.00	(150,679.53)	0.00	(150,679.53)
06	Lunch	0.00	32,296.60	309,453.07	0.00	(309,453.07)	0.00	(309,453.07)

Account Number

Account Description

Expenditure Report by Op. Unit/Function

Lunch fund

	Revised Budget	During Month	Expenditures to Date	% of Budget	Balance at EOM	Encumbrances	Unencumbered Balance
Grand Total:	0.00	32,296.60	309,453.07	0.00	(309,453.07)	0.00	(309,453.07)

**Ravenna Public School
Lunch Fund Report
March 31st, 2025**

Beginning Balance: \$ 29,954.31

RECEIPTS:

Deposit \$ 24,442.66

Transfer from General Fund \$ -

Interest \$ 3.95

Total Receipts: \$ 24,446.61

DISBURSEMENTS:

Lunch Bills \$ 34,793.78

Outstanding Checks \$ 2,017.57

Total Disbursements: \$ 36,811.35

Book Balance \$ 19,607.14

Bank Balance \$ 21,624.71

Account Number	Account Description	Budget	Month to Date	Year to Date
8	Revenue			
06 1510	Interest	0.00	3.95	26.81
06 1611	Student Lunches	0.00	10,877.50	88,221.54
06 1612	Daily Sales-Breakfast	0.00	0.00	0.00
06 1613	Special Milk	0.00	0.00	0.00
06 1620	Daily Sales-Adult/A la Carte	0.00	676.70	7,406.88
06 1650	Daily Sales-Summer Food Programs	0.00	0.00	0.00
06 2100	State Reimbursement	0.00	0.00	0.00
06 2200	Breakfast	0.00	0.00	0.00
06 3150	STATE REIMBURSEMENT	0.00	0.00	1,409.53
06 4210	FEDERAL REIMB. NSLP	0.00	12,854.97	114,141.55
06 5000	Trans From Savings	0.00	0.00	0.00
06 5200	School Dist Contrib.	0.00	0.00	37,000.00
06 5690	Other Income	0.00	33.49	2.40
06 9000	Non Program Receipts	0.00	0.00	0.00
06 9005	Interfund loan from GF to LF	0.00	0.00	0.00
06	Lunch	0.00	24,446.61	248,208.71
8	Revenue	0.00	24,446.61	248,208.71



FRONT RUNNER FAB., INC.

P.O. Box 446

FULLERTON, NE 68638-0446

308-550-0151

10061

INVOICE

DATE: 4-1-25

SOLD TO

Russell D. G. Service

SHIP TO

P.O. # SHIPPED VIA TERMS SALESMAN F.O.B. OUR ORDER #

CHG

Date Shipped Quantity Shipped DESCRIPTION Unit Price Amount

Labor install 12 seasonal

2400

Special Building

see to pay
Schroeder
4-4-25

GREATER of \$5 or 1.5% of balance
charged to balances NOT RECEIVED

by

Thank You!

FRONT RUNNER FAB., INC.

P.O. BOX 446

FULLERTON NE. 68638

Statement

Date
4/1/2025

To:
Ravenna Public Schools 41750 Carthage Rd Ravenna, NE 68869

Amount Due	Amount Enc.
\$2,400.00	

Date	Transaction	Amount	Balance
02/28/2025	Balance forward		0.00
04/01/2025	INV #10061. Due 04/01/2025.	2,400.00	2,400.00

CURRENT	1-30 DAYS PAST DUE	31-60 DAYS PAST DUE	61-90 DAYS PAST DUE	OVER 90 DAYS PAST DUE	Amount Due
2,400.00	0.00	0.00	0.00	0.00	\$2,400.00

2425-740

Larsen Electric, Inc.

46913 774th Rd
Hazard, NE 68844
(308) 440-8582

)

INVOICE

BILL TO
Ravenna Public Schools
PO Box 8400
Ravenna, NE 68869

INVOICE 2098
DATE 04/06/2025

DATE	ACTIVITY	DESCRIPTION	QTY	RATE	AMOUNT
	T101 Time clock	T-101 Mechanical Time Clock	1	128.57	128.57
	Labor	Labor	0.50	85.00	42.50

Replace time clock for outdoor lighting. Thank you for your business!

BALANCE DUE

\$171.07

Pay Invoice

Larsen Electric, Inc.

46913 774th Rd
 Hazard, NE 68844
 (308) 440-8582

2425-741

INVOICE

BILL TO
 Ravenna Public Schools
 PO Box 8400
 Ravenna, NE 68869

INVOICE 2097
DATE 04/06/2025

DATE	ACTIVITY	DESCRIPTION	QTY	RATE	AMOUNT
	200A terminal box	200A terminal box	1	521.43	521.43
	100A terminal box	100 amp terminal box	1	201.64	201.64
	2" Schedule 80 PVC conduit	2" Schedule 80 PVC conduit	6	11.77	70.62
	2" PVC TA	2" PVC male terminal adaptor	2	1.96	3.92
	2" lock nut	2" lock nut	2	1.82	3.64
	2" plastic bushing	2" plastic bushing	2	0.79	1.58
	1" Hub	1" Hub	2	15.03	30.06
	.75" offset nipple	.75" offset nipple	1	5.50	5.50
	.5" offset nipple	.5" offset nipple	1	4.04	4.04
	70A 2 circuit NEMA 3R breaker panel	70A 2 circuit NEMA 3R breaker panel	1	82.86	82.86
	QO120 circuit breaker	QO120 circuit breaker	1	18.86	18.86
	.5" X .75" RB	.5" X .75" reducing bushing	1	7.58	7.58
	1" X .75" RB	1" x .75" Reducing bushing	1	9.97	9.97
	1-gang weather proof bell box	1-gang weather proof bell box	1	13.50	13.50
	1-gang weather proof X-Duty cover	1-gang weather proof Extra Duty device cover	1	21.37	21.37
	WR GFCI receptacle	Weather resistant GFCI receptacle	1	27.74	27.74
	#12 THHN stranded copper wire	#12 THHN stranded copper wire	4	0.39	1.56
	4x4x8 Treated post	4x4x8 Treated post	1	21.56	21.56
	.75" PVC TA	.75" PVC male terminal adaptor	1	0.71	0.71
	.75" lock nut	.75" lock nut	2	0.09	0.18
	.75" plastic bushing	.75" plastic bushing	1	0.26	0.26
	Labor	Labor	4.50	85.00	382.50

Football field wiring. Thank you for your business!

BALANCE DUE

\$1,431.08

Ravenna Public Schools

P.O. Box 8400
 41750 Carthage Rd.
 Ravenna, NE 68869
 Phone: 308.452.3249
 Fax: 308.452.3172

PURCHASE ORDER

Date: 04/06/25
 P.O. # 2425-741
 Bill To: PO Box 8400

Tax Exemption No. 05-627933

VENDOR

Larsen Electric, Inc.

SHIP TO

Ravenna Public Schools
 Attn: Dan Cyboron
 41750 Carthage Road
 Ravenna NE, 68869

BILL TO

Ravenna Public Schools
 Attn: Hilary Bolling
 P.O. Box 8400
 Ravenna NE, 68869

ITEM #	Description	QT	Unit Price	TOTAL
	200A terminal box	1	521.43	521.43
	100 Amp terminal box	1	201.64	201.64
	2" Schedule 80 PVC conduit	6	11.77	70.62
	2" PVC TA	2	1.96	3.92
	2" lock nut	2	1.82	3.64
	2" plastic bushing	2	0.79	1.58
	1" Hub	2	15.03	30.06
	.75" offset nipple	1	5.50	5.50
	.5" offset nipple	1	4.04	4.04
	70A 2 circuit NEMA 3R breaker panel	1	82.86	82.86
	QO120 circuit breaker	1	18.86	18.86
	.5"x.75" RB	1	7.58	7.58
	1"x.75" RB	1	9.97	9.97
	1 gang weather proof bell box	1	13.50	13.50
	1 gang weather proof x duty cover	1	21.37	21.37
	weather resistant GFCI receptacle	1	27.74	27.74
	12 THHN Stranded copper wire	4	0.39	1.56
	4x4x8 treated post	1	21.56	21.56
	.75" PVC TA	1	0.71	0.71
	.75" plastic bushing	1	0.26	0.26
	.75" lock nut	2	0.09	0.18
	labor	4.5	85.00	382.50
				0.00

SUBTOTAL \$1,431.08
 S & H \$0.00
 discount \$0.00
TOTAL \$1,431.08

Other Comments or Special Instructions

Karen E. Schneider 4-9-25

Authorized by Date

2425-746

INVOICE

PLEASE REMIT TO

RASMUSSEN MECHANICAL SERVICES
3211 NEBRASKA AVE.
COUNCIL BLUFFS, IA 51501
Phone: (712) 323-0541



INVOICE NUMBER	SRV120834
INVOICE DATE	3/7/2025
PO NUMBER	APPROVED
TOTAL DUE	\$3,759.00

BILL TO

RAVENNA PUBLIC SCHOOLS
PO BOX 8400
RAVENNA, NE 68869

LOCATION

RAVENNA PUBLIC SCHOOLS
41750 CARTHAGE ROAD
RAVENNA, NE 68869

Service Call 250207-0030

Customer Number	Called In By	Payment Terms
0000664	DAN CYBORON (308) 440-6084 Ext: 0000	NET 30

Description

Q2500945 - EXPANSION TANK REPLACEMENT

2/20/25 REPLACED THE EXPANSION TANK AND FITTINGS. DROPPED THE PRESSURE IN THE TANK DOWN TO 20 PSI AND CHECKED ALL JOINTS FOR LEAKS. ALL CHECKS WERE GOOD.

Subtotal	\$3,759.00
Tax	\$0.00
Total	\$3,759.00

2425-747

INVOICE

PLEASE REMIT TO

RASMUSSEN MECHANICAL SERVICES
3211 NEBRASKA AVE.
COUNCIL BLUFFS, IA 51501
Phone: (712) 323-0541



INVOICE NUMBER	SRV120843
INVOICE DATE	3/7/2025
PO NUMBER	APPROVED
TOTAL DUE	\$9,377.00

BILL TO

RAVENNA PUBLIC SCHOOLS
PO BOX 8400
RAVENNA, NE 68869

LOCATION

RAVENNA PUBLIC SCHOOLS
41750 CARTHAGE ROAD
RAVENNA, NE 68869

Service Call 250207-0032

Customer Number	Called In By	Payment Terms
0000664	DAN CYBORON (308) 440-6084 Ext: 0000	NET 30

Description

Q2500939 - THEATER AIR HANDLER REPAIRS

2/19/25 REPLACED THE BLOWER SHAFT IN THE UNIT. GOT IT ALL BACK TOGETHER AND ALIGNED SO THAT IT WAS NOT RUBBING ANYWHERE IN THE BLOWER HOUSING. TESTED OPERATION AND THE UNIT WAS HEATING AS IT SHOULD.

Subtotal	\$9,377.00
Tax	\$0.00
Total	\$9,377.00

		0% increase in wage	0.5% increase in wage	1% increase in wage	1.5% increase in wage	2% increase in wage	2.5% increase in wage	3% increase in wage	3.25% increase in wage	3.5% increase in wage	3.75% increase in wage	4% increase in wage
	2024-2025 est											
Kitchen												
Gross Wage	\$ 153,465.00	\$ 153,465.00	\$ 154,232.33	\$ 154,999.65	\$ 155,766.98	\$ 156,534.30	\$ 157,301.63	\$ 158,068.95	\$ 158,452.61	\$ 158,836.28	\$ 159,219.94	\$ 159,603.60
Soc Sec/med	\$ 11,740.07	\$ 11,740.07	\$ 11,798.77	\$ 11,857.47	\$ 11,916.17	\$ 11,974.87	\$ 12,033.57	\$ 12,092.27	\$ 12,121.62	\$ 12,150.98	\$ 12,180.33	\$ 12,209.68
Retirement	\$ 15,158.97	\$ 15,158.97	\$ 15,234.76	\$ 15,310.56	\$ 15,386.35	\$ 15,462.15	\$ 15,537.94	\$ 15,613.73	\$ 15,651.63	\$ 15,689.53	\$ 15,727.43	\$ 15,765.32
Insurance	\$ 55,057.68	\$ 58,551.00	\$ 58,551.00	\$ 58,551.00	\$ 58,551.00	\$ 58,551.00	\$ 58,551.00	\$ 58,551.00	\$ 58,551.00	\$ 58,551.00	\$ 58,551.00	\$ 58,551.00
Total	\$ 235,421.72	\$ 238,915.04	\$ 239,816.86	\$ 240,718.68	\$ 241,620.50	\$ 242,522.32	\$ 243,424.14	\$ 244,325.96	\$ 244,776.87	\$ 245,227.78	\$ 245,678.69	\$ 246,129.60
		\$ 3,493.32	\$ 4,395.14	\$ 5,296.96	\$ 6,198.78	\$ 7,100.60	\$ 8,002.42	\$ 8,904.24	\$ 9,355.15	\$ 9,806.06	\$ 10,256.97	\$ 10,707.88
Total Compensation %		101.48%	101.87%	102.25%	102.63%	103.02%	103.40%	103.78%	103.97%	104.17%	104.36%	104.55%
Custodial												
Gross Wage	\$ 228,826.00	\$ 228,826.00	\$ 229,970.13	\$ 231,114.26	\$ 232,258.39	\$ 233,402.52	\$ 234,546.65	\$ 235,690.78	\$ 236,262.85	\$ 236,834.91	\$ 237,406.98	\$ 237,979.04
Soc Sec/med	\$ 17,505.19	\$ 17,505.19	\$ 17,592.71	\$ 17,680.24	\$ 17,767.77	\$ 17,855.29	\$ 17,942.82	\$ 18,030.34	\$ 18,074.11	\$ 18,117.87	\$ 18,161.63	\$ 18,205.40
Retirement	\$ 22,602.97	\$ 22,602.97	\$ 22,715.99	\$ 22,829.00	\$ 22,942.02	\$ 23,055.03	\$ 23,168.05	\$ 23,281.06	\$ 23,337.57	\$ 23,394.08	\$ 23,450.59	\$ 23,507.09
Insurance	\$ 55,400.00	\$ 58,582.00	\$ 58,582.00	\$ 58,582.00	\$ 58,582.00	\$ 58,582.00	\$ 58,582.00	\$ 58,582.00	\$ 58,582.00	\$ 58,582.00	\$ 58,582.00	\$ 58,582.00
Total	\$ 324,334.16	\$ 327,516.16	\$ 328,860.83	\$ 330,205.51	\$ 331,550.18	\$ 332,894.85	\$ 334,239.52	\$ 335,584.19	\$ 336,256.52	\$ 336,928.86	\$ 337,601.19	\$ 338,273.53
		\$ 3,182.00	\$ 4,526.67	\$ 5,871.34	\$ 7,216.01	\$ 8,560.68	\$ 9,905.35	\$ 11,250.02	\$ 11,922.36	\$ 12,594.70	\$ 13,267.03	\$ 13,939.37
Total Compensation %		100.98%	101.40%	101.81%	102.22%	102.64%	103.05%	103.47%	103.68%	103.88%	104.09%	104.30%
Bus Drivers												
Gross Wage	\$ 184,522.00	\$ 184,522.00	\$ 185,444.61	\$ 186,367.22	\$ 187,289.83	\$ 188,212.44	\$ 189,135.05	\$ 190,057.66	\$ 190,518.97	\$ 190,980.27	\$ 191,441.58	\$ 191,902.88
Soc Sec/med	\$ 14,115.93	\$ 14,115.93	\$ 14,186.51	\$ 14,257.09	\$ 14,327.67	\$ 14,398.25	\$ 14,468.83	\$ 14,539.41	\$ 14,574.70	\$ 14,609.99	\$ 14,645.28	\$ 14,680.57
Retirement	\$ 11,702.45	\$ 11,702.45	\$ 11,760.96	\$ 11,819.47	\$ 11,877.99	\$ 11,936.50	\$ 11,995.01	\$ 12,053.52	\$ 12,082.78	\$ 12,112.04	\$ 12,141.29	\$ 12,170.55
Insurance	\$ 8,415.60	\$ 8,766.00	\$ 8,766.00	\$ 8,766.00	\$ 8,766.00	\$ 8,766.00	\$ 8,766.00	\$ 8,766.00	\$ 8,766.00	\$ 8,766.00	\$ 8,766.00	\$ 8,766.00
Total	\$ 218,755.98	\$ 219,106.38	\$ 220,158.08	\$ 221,209.79	\$ 222,261.49	\$ 223,313.19	\$ 224,364.89	\$ 225,416.59	\$ 225,942.45	\$ 226,468.30	\$ 226,994.15	\$ 227,520.00
		\$ 350.40	\$ 1,402.10	\$ 2,453.80	\$ 3,505.51	\$ 4,557.21	\$ 5,608.91	\$ 6,660.61	\$ 7,186.46	\$ 7,712.31	\$ 8,238.16	\$ 8,764.02
Total Compensation %		100.16%	100.64%	101.12%	101.60%	102.08%	102.56%	103.04%	103.29%	103.53%	103.77%	104.01%
Total for ALL		\$ 7,025.72	\$ 10,323.91	\$ 13,622.11	\$ 16,920.30	\$ 20,218.49	\$ 23,516.68	\$ 26,814.88	\$ 28,463.97	\$ 30,113.07	\$ 31,762.17	\$ 33,411.26
Nurse												
Gross Wage	\$ 55,132.00	\$ 55,132.00	\$ 55,407.66	\$ 55,683.32	\$ 55,958.98	\$ 56,234.64	\$ 56,510.30	\$ 56,785.96	\$ 56,923.79	\$ 57,061.62	\$ 57,199.45	\$ 57,337.28
Soc Sec/med	\$ 4,217.60	\$ 4,217.60	\$ 4,238.69	\$ 4,259.77	\$ 4,280.86	\$ 4,301.95	\$ 4,323.04	\$ 4,344.13	\$ 4,354.67	\$ 4,365.21	\$ 4,375.76	\$ 4,386.30
Retirement	\$ 5,445.83	\$ 5,445.83	\$ 5,473.06	\$ 5,500.29	\$ 5,527.52	\$ 5,554.75	\$ 5,581.97	\$ 5,609.20	\$ 5,622.82	\$ 5,636.43	\$ 5,650.05	\$ 5,663.66
Insurance	\$ 10,179.72	\$ 10,738.56	\$ 10,738.56	\$ 10,738.56	\$ 10,738.56	\$ 10,738.56	\$ 10,738.56	\$ 10,738.56	\$ 10,738.56	\$ 10,738.56	\$ 10,738.56	\$ 10,738.56
Total	\$ 74,975.15	\$ 75,533.99	\$ 75,857.96	\$ 76,181.94	\$ 76,505.92	\$ 76,829.90	\$ 77,153.87	\$ 77,477.85	\$ 77,639.84	\$ 77,801.83	\$ 77,963.82	\$ 78,125.80
		\$ 558.84	\$ 882.82	\$ 1,206.79	\$ 1,530.77	\$ 1,854.75	\$ 2,178.73	\$ 2,502.70	\$ 2,664.69	\$ 2,826.68	\$ 2,988.67	\$ 3,150.66
Total Compensation %		100.75%	101.18%	101.61%	102.04%	102.47%	102.91%	103.34%	103.55%	103.77%	103.99%	104.20%
Office												
Gross Wage	\$ 211,731.00	\$ 211,731.00	\$ 212,789.66	\$ 213,848.31	\$ 214,906.97	\$ 215,965.62	\$ 217,024.28	\$ 218,082.93	\$ 218,612.26	\$ 219,141.59	\$ 219,670.91	\$ 220,200.24
Soc Sec/med	\$ 16,197.42	\$ 16,197.42	\$ 16,278.41	\$ 16,359.40	\$ 16,440.38	\$ 16,521.37	\$ 16,602.36	\$ 16,683.34	\$ 16,723.84	\$ 16,764.33	\$ 16,804.82	\$ 16,845.32
Retirement	\$ 20,914.36	\$ 20,914.36	\$ 21,018.94	\$ 21,123.51	\$ 21,228.08	\$ 21,332.65	\$ 21,437.22	\$ 21,541.80	\$ 21,594.08	\$ 21,646.37	\$ 21,698.65	\$ 21,750.94
Insurance	\$ 66,273.24	\$ 69,911.52	\$ 67,592.08	\$ 66,273.10	\$ 66,273.10	\$ 69,911.52	\$ 69,911.52	\$ 69,911.52	\$ 69,911.52	\$ 69,911.52	\$ 69,911.52	\$ 69,911.52
Total	\$ 315,116.03	\$ 318,754.31	\$ 317,679.08	\$ 317,604.32	\$ 318,848.53	\$ 323,731.16	\$ 324,975.38	\$ 326,219.59	\$ 326,841.70	\$ 327,463.80	\$ 328,085.91	\$ 328,708.02
		\$ 3,638.28	\$ 2,563.05	\$ 2,488.29	\$ 3,732.50	\$ 8,615.14	\$ 9,859.35	\$ 11,103.56	\$ 11,725.67	\$ 12,347.78	\$ 10,650.44	\$ 13,591.99
Total Compensation %		101.15%	100.81%	100.79%	101.18%	102.73%	103.13%	103.52%	103.72%	103.92%	103.38%	104.31%
Grand Total ALL		\$ 11,222.84	\$ 13,769.78	\$ 17,317.19	\$ 22,183.57	\$ 30,688.38	\$ 35,554.76	\$ 40,421.14	\$ 42,854.34	\$ 45,287.53	\$ 45,401.28	\$ 50,153.91
Technology												
	2022-2023	2023-2024	2024-2025									
Gross Wage	\$ 70,000.00	\$ 72,500.00	\$ 75,000.00	3 year work agreement is up 8/31/2025								
Soc Sec/med	\$ 5,355.00	\$ 5,546.25	\$ 5,737.50									
Retirement	\$ 6,916.00	\$ 7,163.00	\$ 7,410.00									
Insurance	\$ 402.48	\$ 402.48	\$ 409.56									
Total	\$ 82,673.48	\$ 85,611.73	\$ 88,557.06									

Paras*	SPED expenditure not included in general fund expenditures or budget authority												
Gross Wage	\$ 264,683.00	\$ 264,683.00	\$ 266,006.42	\$ 267,329.83	\$ 268,653.25	\$ 269,976.66	\$ 271,300.08	\$ 272,623.49	\$ 273,285.20	\$ 273,946.91	\$ 274,608.61	\$ 275,270.32	
Soc Sec/med	\$ 20,248.25	\$ 20,248.25	\$ 20,349.49	\$ 20,450.73	\$ 20,551.97	\$ 20,653.21	\$ 20,754.46	\$ 20,855.70	\$ 20,906.32	\$ 20,956.94	\$ 21,007.56	\$ 21,058.18	
Retirement	\$ 26,144.86	\$ 26,144.86	\$ 26,275.58	\$ 26,406.31	\$ 26,537.03	\$ 26,667.75	\$ 26,798.48	\$ 26,929.20	\$ 26,994.57	\$ 27,059.93	\$ 27,125.29	\$ 27,190.65	
Insurance	\$ 40,627.15	\$ 52,961.60	\$ 52,961.60	\$ 52,961.60	\$ 52,961.60	\$ 52,961.60	\$ 52,961.60	\$ 52,961.60	\$ 52,961.60	\$ 52,961.60	\$ 52,961.60	\$ 52,961.60	
Total	\$ 351,703.26	\$ 364,037.71	\$ 365,593.09	\$ 367,148.47	\$ 368,703.85	\$ 370,259.23	\$ 371,814.61	\$ 373,369.99	\$ 374,147.68	\$ 374,925.37	\$ 375,703.06	\$ 376,480.75	
		\$ 12,334.45	\$ 13,889.83	\$ 15,445.21	\$ 17,000.59	\$ 18,555.97	\$ 20,111.35	\$ 21,666.73	\$ 22,444.42	\$ 23,222.11	\$ 23,999.80	\$ 24,777.49	
Total Compensation %		103.51%	103.95%	104.39%	104.83%	105.28%	105.72%	106.16%	106.38%	106.60%	106.82%	107.05%	

Board of Education Regular Meeting

High School Library
P.O. Box 8400
Ravenna, NE 68869-8400

Monday, March 10, 2025 7:00 PM

Kelly Bock: Present
Misti Fiddelke: Present
Micah Miigerl: Present
Ryan Osten: Present
Dawn Standage: Present
Mike Voelker: Present

1. Call to Order and Roll Call - Open Meeting Law
2. Excuse Absent Board Members
3. The Pledge of Allegiance
4. Recitation of School Mission Statement: ***Preparing Students Today to Succeed Tomorrow: Family-Community-School***
5. Recitation of Board Mission Statement: ***Providing collaborative leadership to prepare students today to succeed tomorrow.***
6. Approval of Agenda
Motion to approve the agenda passed with a motion by Ryan Osten and a second by Mike Voelker.
7. Financial Report
8. Consent Agenda
Motion to approve the consent agenda passed with a motion by Mike Voelker and a second by Ryan Osten.
 - 8.1. Discuss, consider, and take all necessary action to minutes
 - 8.2. Discuss, consider, and take all necessary action to bills
 - 8.3. Notice of Meeting Publication: The notice for this board meeting was published in the March 5th Edition of *The Ravenna News*

8.4. Discuss, consider, and take all action necessary to the resignation of Ms. Jennifer Hanna, middle school science teacher

8.5. Discuss, consider, and take all action necessary to the resignation of Mrs. Hannah Turek

9. Blue Jay Celebration of Success - Junior High Girls Wrestling - Mrs. Yendra & Mrs. Rasmussen

10. Artist of the Month - Kayla Burr

11. Request to Address the Board and Correspondence

12. Information and Action Items

12.1. Discuss, consider, and take all action necessary to Ravenna Public School Board Policy 5022

Motion to adopt policy 5022 as presented and to rescind all previous versions of this policy passed with a motion by Micah Miigerl and a second by Ryan Osten.

12.2. Discuss, consider, and take all action necessary to the 2025-26 Ravenna Public Schools Calendar

Motion to approve the 2025-26 school calendar as presented passed with a motion by Mike Voelker and a second by Kelly Bock.

12.3. Discuss, consider, and take all action necessary to student laptop computer refresh - Dave Huryta

Motion to approve the purchase of 9-12 laptop computers in an amount to not exceed \$134,000 from the Depreciation Fund passed with a motion by Micah Miigerl and a second by Mike Voelker.

13. Discussion Items

13.1. Discuss, consider, and take all action necessary to the revision of the school district's teacher evaluation instrument

13.2. Discuss, consider, and take all action necessary to the review and purchase of the new elementary language arts curriculum

13.3. Discuss, consider, and take all action necessary to classified staff compensation for the 2025-26 school year

13.4. Discuss, consider, and take all action necessary to the girls high school wrestling program

13.5. Discuss, consider, and take all action necessary to one-act directors' compensation on the 2025-26 extra duty schedule

14. Elementary Principal's Report

15. Secondary Principal's Report

16. Superintendent's Report

17. Board Report

18. Positive Comments

Thanks to the Ravenna Public School Staff, (especially Dave Huryta & Stacie Loeffelholz), the students, and the members of the community, for all of their efforts in supporting the bond project campaign over the last couple of months. -Ryan Osten

19. Adjournment

Motion to adjourn at 9:32 PM passed with a motion by Ryan Osten and a second by Micah Miigerl.

Board of Education Regular Meeting

High School Library
P.O. Box 8400
Ravenna, NE 68869-8400

Monday, March 24, 2025 7:00 PM

1. Call to Order and Roll Call - Open Meeting Law

2. Excuse Absent Board Members

Motion to excuse absent board member, Mr. Micah Miigerl, passed with a motion by Ryan Osten and a second by Mike Voelker.

3. The Pledge of Allegiance

4. Recitation of School Mission Statement: ***Preparing Students Today to Succeed Tomorrow: Family-Community-School***

5. Recitation of Board Mission Statement: ***Providing collaborative leadership to prepare students today to succeed tomorrow.***

6. Approval of Agenda

Motion to approve the agenda passed with a motion by Mike Voelker and a second by Ryan Osten.

7. Consent Agenda

Motion to approve the consent agenda passed with a motion by Ryan Osten and a second by Mike Voelker.

7.1. Discuss, consider, and take all necessary action to minutes

7.2. Notice of Meeting Publication: The notice for this board meeting was published in the March 19th Edition of *The Ravenna News*

8. Request to Address the Board and Correspondence

9. Information and Action Items

9.1. Discuss, consider, and take all action necessary to the Ravenna Public Schools Bond Election Results and election bill

Motion to approve payment of the election bill from the Buffalo County Election Commissioner's Office passed with a motion by Mike Voelker and a second by Kelly Bock.

9.2. Discuss, consider, and take all action necessary to bond issuance in conjunction with building project (Guest Speaker - Tobin Buchanan)

No action taken.

9.3. Discuss, consider, and take all action necessary to the architect's contract for the RPS Bond Project

Motion to approve contract with Jacob Sertich for architectural services passed with a motion by Dawn Standage and a second by Ryan Osten.

9.4. Discuss, consider, and take all action necessary to plan design for the RPS Bond Project (Guest Speaker - Mr. Jacob Sertich)

No action taken.

9.5. Discuss, consider, and take all action necessary to football field/track lighting

No action taken.

10. Superintendent's Report

11. Board Report

12. Positive Comments

13. Adjournment

Surplus Library Books

Title	Author
Arachnid The Spider King	Adam Blade
The Education of Little Tree	Forrest Carter
Hannah Montana Win or Lose	Heather Alexander
Sugar Plums to the Rescue	Whoopi Goldberg
Lunchbox and the Aliens	Bryan W. Fields
Willow Run	Patricia Reilly Giff
Shen of the Sea	Arthur Bowie Chrisman
The Gawgon and the Boy	Lloyd Alexander
The Case of Camp Pom-Pom	Heather Alexander
The Hero of Ticonderoga	Gail Gauthier
The Soul of the Sawyer Dog	Lynn Hall
Goblins on the Prowl	Bruce Coville
Stone Fox	John Reynolds Gardiner
Flying Solo	Ralph Fletcher
Pinky Eye	Eleanor Estes
Hockey Dreams	Gil Conrad
Cupid Doesn't Flip Hamburgers	Dadey/Jones
Terror at the Zoo	Peg Kehret
Sahara Special	Esme Raji Codell
Claws	Mike and Rachel Grinti
The Roar	Emma Clayton
The 13th Floor: A Ghost Story	Sid Fleischman
Dolphin Freedom	Wayne Grover
Lily to the Rescue	Bruce W. Cameron
Movie for Dogs	Lois Duncan
Into the Blue	Ben M. Baglio
Gregor the Overlander	Suzanne Collins
Child of the Wolves	Elizabeth Hall
Diamond Willow	Helen Frost
Among the Hidden	Margaret Peterson Haddix
Birdwing	Rafe Martin
The Dream Stealer	Sid Fleischman
Jim Ugly	Sid Fleischman
Mrs. Lilly is Silly	Dan Gutman
The Incredible Journey	Sheila Burnford
Double Dog Dare	Jamie Gilson
Ginger Pye	Eleanor Estes
Brendan Buckley's Universe and Everything In It	Sundee Frazier
Ruined	Paula Morris
Distant Waves	Suzanne Weyn
Lost and Found	Anne Schraff
Dragon Keeper	Carole Wilkinson
Forget Me Not	Coleen Murtagh Paratore
The Mysterious Matter of I.M. Fine	Diane Stanley
Call Me Ruth	Marilyn Sachs
Lord of the Deep Graham Salisbury	Graham Salisbury
No Dogs Allowed!	Bill Wallace

Dinosaur Detectives	Judith Bauer Stamper
Bartleby of the Mighty Mississippi	Phyllis Shalant
The Search for Belle Prater	Ruth White
Even More Short & Shivery	Robert D. San Souci
Snot Stew	Bill Wallace
Rascal	Sterling North
The Great Wall of Lucy Wu	Wendy Wan-Long Shang
Skull Island	Lesley Sims
Help! Somebody Get Me Out of Fourth Gradel	Henry Winkler
The Mysterious Matter of I.M. Fine	Diane Stanley
Pick of the Litter	Bill Wallace
Powerpuff Professor	Amy Keating Rogers
The Big One-Oh	Dean Pitchford
Donuthead	Sue Stauffacher
Frankly Frannie: Doggy Day Care	AJ Stern
Stat: Home Court	Amar'e Stoudemire
Winter Thunder	Mari Sandoz
In Care of Cassie Tucker	Ivy Ruckman
Brand-New Emily	Ginger Rue
My Secret Life as a Ping-Pong Wizard	Henry Winkler
Niagara Falls or Does It?	Henry Winkler
Day of the Iguana	Henry Winkler
Holy Enchilada	Henry Winkler
My Dog's a Scaredy-Cat	Henry Winkler
The Curtain Went Up, My Pants Fell Down	Henry Winkler
Moby Dog	Alexander Steele
The Trumpet of the Swan	E.B. White
Milkweed	Jerry Spinelli
The Dragon's Eye	Dugald A. Steer
The Castle Corona	Sharon Creech
Harriet the Spy	Louise Fitzhugh
Joey Pigza Swallowed the Key	Jack Gantos
Maxi's Secret	Lynn Plourde
The Horsecatcher	Mari Sandoz
Stargirl	Jerry Spinelli
Breadcrumbs	Anne Ursu
Crash	Jerry Spinelli
Love, Ruby Lavender	Deborah Wiles
The Silent Stranger	Janet Shaw
Mia	Laurence Yep
Graveyard Shift	Chris Westwood
Listening for Lions	Gloria Whelan
Goosed!	Bill Wallace
Beauty	Bill Wallace
Dogs Don't Tell Jokes	Louis Sachar
Song of the Sparrow	Lisa Ann Sandell
Lyddie	Katherine Paterson
Stay Alive	Rodman Philbrick
Song of the Summer King	Jess E. Owen

Children of the Mind	Orson Scott Card
Premonitions	Jude Watson
Molly Marches On	Valerie Tripp
The Hobbit	J.R.R. Tolkien
The Weekend Was Murder!	Joan Lowery Nixon
Black Beauty	Anna Sewell
Memory Boy	Will Weaver
Frankenstein	Mary Shelley
Miriam's Well	Lois Ruby
JoJo & Bow Bow Take the Stage	JoJo Siwa
Disappearance	Jude Watson
Treasure Island	Robert Louis Stevenson
The Silent Storm	Sherry Garland
I Got a D in Salami	Henry Winkler
The Black Pearl	Scott O'Dell
Jacob Have I Loved	Katherine Paterson
Stay! Keeper's Story	Lois Lowry
Perloo The Bold	Avi
The Ballad of Lucy Whipple	Karen Cushman
Captain's Command	Anna Myers
Cornelia and the Audacious Escapades of the Somerset	Lesley M. M. Blume
Midnight Magic	Avi
Nightmare Academy Monster Hunters	Dean Lorey
The Tail of Emily Windsap	Liz Kessler
Little Big League	Ronald Kidd
Number the Stars (2)	Lois Lowry
Jaguar	Roland Smith
Spying on Miss Muller	Eve Bunting
The Chocolate Touch	Patrick Skene Catling
Dinotopia: Windchaser	Scott Ciencin
Nellie Bishop	Clara Gillow Clark
The Landry News	Andrew Clements
EverWorld: Entertain the End	K.A. Applegate
Tuck Everlasting (2)	Natalie Babbitt
The Rise and Fall of the Kate Empire	Kirsten Larsen
A Message from the Match Girl	Janet Taylor Lisle
Pennyroyal Academy	M.A. Larson
Lostman's River	Cynthia DeFelice
Gregor and the Prophecy of Bane	Suzanne Collins
Chicken Boy	Frances O'Roark Dowell
The Whipping Boy	Sid Fleischman
Things Hoped For	Andrew Clements
Football Genius	Tim Green
The Mailbox	Audrey Shafer
Ella Enchanted	Gail Carson Levine
Animorphs: The Beginning	K.A. Applegate
Animorphs: The Revelation	K.A. Applegate
Animorphs: The Test	K.A. Applegate
Animorphs: The Other	K.A. Applegate

Animorphs: The Weakness	K.A. Applegate
Animorphs: The Prophecy	K.A. Applegate
Animorphs: The Sickness	K.A. Applegate
Animorphs: The Experience	K.A. Applegate
Animorphs: The Threat	K.A. Applegate
Animorphs: The Android	K.A. Applegate
Animorphs: The Secret	K.A. Applegate
Animorphs: The Stranger	K.A. Applegate
Animorphs: The Capture	K.A. Applegate
Animorphs: The Predator	K.A. Applegate
Animorphs: The Message	K.A. Applegate
Animorphs: The Visitor	K.A. Applegate
Animorphs: The Separation	K.A. Applegate
Animorphs: The Conspiracy	K.A. Applegate
Animorphs: The Reunion	K.A. Applegate
Animorphs: The Sickness	K.A. Applegate
Animorphs: The Prophecy	K.A. Applegate
Animorphs: The Illusion	K.A. Applegate
Animorphs: The Separation	K.A. Applegate
Animorphs: The Visitor	K.A. Applegate
Animorphs: The Invasion	K.A. Applegate
Animorphs: The Invasion	K.A. Applegate
Animorphs: Elfangor's Secret	K.A. Applegate
Collection of Storytime Favorites	Various Authors
I'm Not Who You Think I am	Peg Kehret
Danger at the Fair	Peg Kehret
Horror at the Haunted House	Peg Kehret
Melonhead	Katy Kelly
The Cat Burglar	Tessa Krailing
Dachshund in Danger!	Ben M. Baglio
Flash Forward	Chris Archer
Short & Sweet Ranch	Nadine Davies
Dovey Coe	Frances O'Roark Dowell
A Week in the Woods	Andrew Clements
Trouble in Pembroke	Mary Casanova
Shadow Spinner	Susan Fletcher
The Summer of Riley	Eve Bunting
Winter according to Humphrey	Betty G. Birney
Jefferson's Sons	Kimberln Brubaker Bradley
Invasion of the Insects	Ada Hopper
Muttketeer!	Bill Crider
From Bad to Cursed	Katie Alender
Souder	William H. Armstrong
In the Stone Circle	Elizabeth Cody Kimmel
The Birthday Room	Kein Henkes
Inside Out & Back Again	Thanhha Lai
Molly Moon's Incredible Book of Hypnotism	Georgia Byng
Tangerine	Edward Bloor
Beast Quest: Zepha the Monster Squid	Adam Blade

Beast Quest: Epos the Winged Flame	Adam Blade
Stolen Children	Peg Kehret
Stealing Thunder	Mary Casanova
The Doll in the Garden	Mary Downing Hahn
The School Story	Andrew Clements
One-Eyed Cat	Paula Fox
The Beastly Arms	Patrick Jennings
River Thunder	Will Hobbs
Jericho	Janet Hickman
The Last Newspaper Boy In America	Sue Corbett
Lion Boy	Zizou Corder
The Anybodies	N.E. Bode
The Fledgling	Jane Langton
Gooney Bird Greene	Lois Lowry
Pippi Longstocking	Astrid Lindgren
The New Pig In Town	Coco La Rue
Penny From Heaven	Jennifer L. Holm
Jake Drake, Bully Buster	Andrew Clements
Far North	Will Hobbs
Ghost Canoe	Will Hobbs
Touching Spirit Bear	Ben Mikaelson
Fantastic Beasts and Where to Find Them	J.K. Rowling
A Horse Called Wonder	Joanna Campbell
Ramona and Her Mother	Beverly Cleary
Ramona Quimby Age 8	Beverly Cleary
Strider (2)	Beverly Cleary
Henry and the Clubhouse	Beverly Cleary
Ramona the Pest	Beverly Cleary
Ramona the Brave	Beverly Cleary
Olive's Ocean	Kevin Henkes
Hannah Montana: Don't Bet on It	Ann Lloyd
Icefire	Chris D'Lacey
Drama Queen	Lara Bergen
The New You	Kathleen Leverich
The Great Big Paw Print	Poppy Green
Full Tilt	Neal Shusterman
The Secret of Platform 13	Eva Ibbotson
Winter Camp	Kirkpatrick Hill
Zach's Lie	Roland Smith
The Breadwinner	Deborah Ellis
The People of Sparks	Jeanne Duprau
The Star of Kazan	Eva Ibbotson
The Cat Who Went to Heaven	Elizabeth Coatsworth
Skylark	Patricia McLaughlin
Sara, Plain and Tall	Patricia McLaughlin
Shimmer	Alyson Noel
The Last Man's Reward	David Patneaude
Cages	Peg Kehret
Ashes of Roses	Mary Jane Auch

Tales of a Fourth Grade Nothing	Judy Blume
Then Again, Maybe I Won't	Judy Blume
Otherwise Known as Sheila the Great	Judy Blume
Dolphin Tale 2	Gabrielle Reyes
No Such Thing As Dragons	Phillip Reeve
Aerican Chillers	Johnathan Rand
Caddie Woodlawn	Carol Ryrie Brink
Robinson Crusoe	Pierce Brosnan
The Midwife's Apprentice	Karen Cushman
Accept No Substitutions	Stan & Jan Berenstain
Sophie the Hero	Lara Bergen
The Berenstain Bear Scouts and the Sci-Fi Pizza	Stan & Jan Berenstain
I've Got a Secret	Lara Bergen
The Dog Who Thought He Was Santa	Bill Wallace
Red Dirt Jessie	Anna Myers
The Friendship Doll	Kirby Larson
Winner's Walk	Nancy Ruth Patterson
The Hunt for the Seventh	Christine Morton-Shaw
I Know Who Likes You	Doug Cooney
Franny Parker	Hannah Roberts McKinnon
It's Like This, Cat	Emily Neville
Miss Spitfire: Reaching Helen Keller	Sarah Miller
Radiance	Alyson Noel
Nothing Wrong with a Three-Legged Dog	Graham McNamee
Ghosthunters and the Totally Moldy Baroness	Cornelia Funke
Rock N Roll Dog	Martha Freeman
A Crooked Kind of Perfect	Linda Urban
Wild Survival: Crocodile Rescue	Melissa Cristina Marquez
Marty McQuire	Kate Messner
Wander	Susan Hart Lindquist
The Mystery at Miss Abigail's	Lois Gladys Leppard
Marcus Vega Doesn't Speak Spanish	Pablo Cartaya
Misy of Chincoteague	Marguerite Henry
The Good Liar	Gregory Maguire
The Tale of Peter Rabbit	Beatrix Potter
Night of the Howling Dogs	Graham Salisbury
The Secret of Laurel Oaks	Lois Ruby
What My Sister Remembered	Marilyn Sachs
Jake the Fake Keeps it Real	Craig Robinson
The Case of the Killer Bugs	Jay Montavon
Miles' Song	Alice McGill
Orphan Train Children: Will's Choice	Joan Lowey Nixon
Young Indiana Jones and the Ghostly Riders	William McCay
Alaska	Frank Lauria
The Haunting of Gabriel Ashe	Dan Poblocki
Eggs	Jerry Spinelli
Truth is a Bright Star: A Hopi Adventure	Joan Price
The Magic Thief	Sarah Prineas
A Dog's Porpoise	M.C. Ross

Maniac Magee
Lily's Ghosts
Breaking Rank
Don't Call Me Toad!
Choosing Up Sides
The Land of Forgotten Girls
The Boy Who Save Baseball
Fever 1793
Woof
Hannah Montana: On the Road

Jerry Spinelli
Laura Ruby
Kristen D. Randle
Mary Francis Shura
John H. Ritter
Erin Entrada Kelly
John H. Ritter
Laurie Halse Anderson
Spencer Quinn
Kitty Richards

Ravenna FFA Chapter
Ravenna, Nebraska



Macey

RAMCO

RAMCO







2 Gallon

ActiveAQUA™
HYDRO CULTURE

GROW FLOW

Flood & Drain Expansion Kit
6-Pack

Black & Decker®
VALVE REFACER

WORK HEAD
MOTOR

VOLTS AC/DC
AMPS



WHEEL HEAD
MOTOR

VOLTS AC/DC
AMPS



USE GRINDING
HEELS SUITABLE
FOR 5500 RPM



CAT. NO.

TYPE

SER. NO.

THE BLACK & DECKER MFG. CO. TDW503





RAVENNA

R MIG 215 MPI
DLN
CTRIC

220

220



...cklets
...urt of liquid.
... los ahogarse.
... los niños alejados de los
... que solamente tengan
... poco de líquido.
... can't pour water down it
... it's heavy.
... the water into the can,
... it's important and it's
... of water.





12/19/00
1G842AA

Husq

CLASSIC MOTOR













Junior High Girls Wrestling

Year One





Roster

- 6th grade/mat maid: Kymber Sundermeier
- 7th grade: Haylee Larsen
- 8th grade: Brinley Palser, Addison Huryta, Ava Wroblewski, Charlotte Skaggs, Ana Huryta, Emma Wenzke
- High School: Grace Kroll, Lillie Johnson, Zoey Morrow
- Recent Interest-Paisley Musil, Makenna Treffer

Interest for next year varsity: 6-8 students verbal confirmation

Weight Classes

Haylee Larsen: 104-106

Brinley Palser: 108-110

Addison Huryta: 122-125

Ava Wroblewski: 126-129

Charlotte Skaggs: 156-160

Ana Huryta: 160-162

Emma Wenzke: 175-178

Wrestling Levels

Beginners (0 years experience): Addison Huryta, Charlotte Skaggs, Ana Huryta, Emma Wenze

Intermediate (1+ years experience): Haylee Larsen

Good (2+ years experience): Brinley Palser, Ava Wroblewski

Excellent (3+ years experience, youth wrestling): none

Season 1 Statistics

1st places: 10

2nd places: 10

3rd places: 11

4th places: 3

Example Practice Plan

Focus: Takedowns and securing the half

Dynamic Warmup: Jog 2 min, arm circles, high knees

butt kicks, line progression (4 min.)

Steeple Shots + Frog Jumps (4 min.)

Spin Drill (2 min.)

Drilling: Stance & Motion (1 min x 3) Single Legs, Double Legs (10 reps each) (15 min.)

Washout: Sumo Game 2 rounds (5 min.)

Technique: Review: Doubles, Singles, Climb the Ladder-put in the half w/ wrist New: Chicken Wing, Barb Wire (25 min.)

Drill: Top and Bottom Position-Referees (15 min.)

Washout: Army Crawls, Bear Crawls, Crab Walks (5 min.)

Conditioning: 7's x 3, pushups and bridges to roll out x 12, Russian Twists + Dead Bugs x 3 (15 min.)

Stretching as a Team

Notes to Share:

Youth Wrestling

PreK-2nd grade: 7 girls

3rd-6th grade: 2 girls

PUBLIC PARTICIPATION

INSTRUCTIONS FOR MEMBERS OF THE PUBLIC WHO WISH TO SPEAK:
This is the portion of the meeting when members of the public may speak to the board about matters of public concern.

- **Getting Started:** When you have been recognized, please stand and state your name.
- **Time Limit:** The board will generally allow a total of 30 minutes for the presentation of all public comments. Individuals may speak only one time, and must limit comments to around 5 minutes. If there are more than 6 individuals who wish to address the board, the 30 minutes will be divided equally between the number of speakers. These time limits may be changed by a majority vote of the board members in attendance to extend the time for a specific item or speaker.
- **Personnel or Student Topic:** If you are planning to speak about a personnel or a student matter involving an individual, please understand that the district has a complaint policy and/or procedures to resolve such complaints and concerns. The Board requests that you follow the policy and procedures before addressing these matters with the Board. Board members will generally not respond to any questions you ask or comments about individual staff members or students.
- **General Rules:** This is a public meeting for the conduct of business. Comments from the audience while others are speaking will not be tolerated. Lewd, obscene, profane, slanderous, threatening and hostile conduct or statements and fighting words (words whose mere utterance entails a call to violence) will not be tolerated.
- **No Action by the Board:** The board will not act on any matter unless it is on the published agenda.

TEACHER'S CONTRACT

For Class II, III, & VI Schools and Class I Schools with a Superintendent

THIS CONTRACT made by and between the School District of Ravenna, District No. 69, in the County of Buffalo, in the State of Nebraska, hereinafter referred to as the District, and Madison Gross, a legally qualified teacher, hereinafter referred to as Teacher.

WITNESSETH: That the Board of Education of the District hereby agrees to employ the Teacher above named in the schools of the District for a school year, which shall begin on or about August 8th, 2025 and end on or about May 20th, 2026, and shall consist of 182 days of service and that the Teacher hereby agrees to accept such employment at a salary of \$38,500.00 (pending Superintendent review) and under the following conditions.

FIRST: The salary of the Teacher shall be payable in twelve equal installments. The first installment shall be payable on the 20th day of September, 2025, and the remaining installments shall be payable on the 20th day of each month thereafter.

SECOND: The teacher hereby agrees to be governed by the policies of the Board of Education of the District and that the teaching duties to be performed by him/her under this contract shall be subject to assignment of the Superintendent of the District with the approval of the Board of Education of the District; and further agrees to devote full time, during days of school to his/her position in all respects, to diligently and faithfully perform the assigned duties as Teacher to the best of his/her professional ability.

THIRD: In addition to the teaching duties set forth herein, the Teacher may be assigned such "extra duty" assignments as defined from time to time by the parties of this agreement which shall be upon such terms and conditions and at such additional stated rate of compensation as the Teacher and the District may from time to time agree upon.

FOURTH: This contract may be canceled or amended by a majority of the members of the school board during the school year for any of the following reasons: (a) upon cancellation, termination, revocation or suspension of the teacher's certificate by the State Board of Education; (b) breach of any of the material provisions of this contract; (c) for any reason set forth in this contract; (d) incompetency; (e) neglect of duty; (f) unprofessional conduct; (g) insubordination; (h) immorality, or (i) physical or mental incapacity. Cancellation or amendment under this contract shall be governed by the provisions of 79-12,110, R.R.S. (1982 Supp.)

FIFTH: That upon termination of this contract for just cause, or upon the release of the Teacher from this contract, the compensation paid or to be paid hereunder shall be an amount which bears the same ratio to the yearly salary herein specified as the number of days of service to the date of such termination bears to 182 days of service. Any unearned fractional portion of an installment paid but not earned prior to termination of the contract shall be refunded by the Teacher.

SIXTH: There shall be no penalty for release or resignation by the Teacher from this contract; provided no resignation shall become effective until the close of the school year unless accepted by the Board of Education of the District and the Board shall fix the time at which the resignation is to take effect.

SEVENTH: This contract shall conform to the regulations governing deductions from the above stated compensation with reference to Withholding Tax, Social Security and Teachers Retirement. Other deductions may be withheld as agreed to by the parties to this contract.

EIGHTH: The Teacher hereby affirms that he/she is not under contract with another School Board or Board of Education within this State covering a part or all of the same time of performance as is contemplated by this agreement. The Teacher further affirms that at the beginning of the term of this contract he/she holds or will hold a valid Nebraska Teaching Certificate. It is understood and agreed that this contract is not valid until the Teacher's Certificate, as herein listed, is registered in the office of the Superintendent of Schools in this County and that the Teacher shall not be compensated for any services performed prior to the date of registration of this certificate.

NINTH: Terms and conditions set forth in this agreement shall be subject to such wages and conditions of employment as may, from time to time, be mutually agreed upon by and between the Board and teachers or a duly recognized collective bargaining agent for said teachers, and said agreement, when reduced to writing, and executed by the parties, shall be deemed to be included herein by reference and shall become a part hereof.

TENTH: Hereafter, this contract may be continued by a separate, annual written "Renewal Agreement" which shall incorporate all the provisions hereof by reference, except as stated on such Renewal Agreement. Renewal Agreements or renewal contracts must be executed by the Teacher and delivered to the Superintendent of Schools or the Secretary of the Board of Education of the District within fifteen (15) calendar days of receipt thereof from the district. Said Renewal Agreement or renewal contract shall not be offered to the Teacher prior to March 15th. Contract renewal, amendment, termination or cancellation shall also be subject to the requirements of Sections 79-12,111 through 79-12,114 R.R.S. (1982 Supp) and any other applicable state statutes.

ELEVENTH: The failure to return a signed copy of the contract or renewal agreement to the Superintendent of Schools or Secretary of the Board of Education of the district on or before January 13th, 2025 shall constitute a rejection by the teacher of the offer of employment.

TWELFTH: Other Contract Terms:

BA A0 1.00 (pending Superintendent review)

Contract is contingent upon the passing of content test, praxis and obtaining an Alternative Teaching Certificate

Executed this 14th day of April, 2025, Madison Gross Teacher

School District of Ravenna, District #69, County of Buffalo, State of Nebraska

Executed this 14th day of April, 2025

President: _____

Secretary: _____

RESOLUTION AUTHORIZING THE ISSUANCE, SALE AND DELIVERY OF GENERAL OBLIGATION BONDS IN AN AGGREGATE PRINCIPAL AMOUNT NOT TO EXCEED \$5,500,000; PRESCRIBING THE FORM OF THE BONDS; FIXING IN PART AND PROVIDING FOR THE FIXING IN PART OF THE TERMS OF THE BONDS; PROVIDING FOR THE LEVY AND COLLECTION OF TAXES TO PAY THE PRINCIPAL OF AND INTEREST ON THE BONDS; AND RELATED MATTERS.

BE IT RESOLVED BY THE BOARD OF EDUCATION OF BUFFALO COUNTY SCHOOL DISTRICT 0069 (RAVENNA PUBLIC SCHOOLS) IN THE STATE OF NEBRASKA:

Section 1. The Board of Education (the “**Board**”) of Buffalo County School District 0069 (Ravenna Public Schools) in the State of Nebraska (the “**District**”) hereby finds and determines as follows:

(a) The District is duly organized as a Class III school district under Sections 79-102 and 79-407, Reissue Revised Statutes of Nebraska, as amended, maintaining both elementary and high school grades under the direction of a single board of education.

(b) Pursuant to Chapter 10, Article 7, Reissue Revised Statutes of Nebraska, as amended (the “**Act**”), the Board has the authority, upon a majority vote of electors voting at a special election held March 11, 2025 (the “**Election**”) to pay the costs of constructing additions, renovations and improvements to the District’s existing school buildings and facilities, and providing necessary equipment and apparatus for such buildings and facilities (the “**Project**”); with such bonds to be issued in one or more series, at such time or times, to bear interest at such rate or rates, to be sold at such prices and to become due at such time or times as may be fixed by, or determined at the direction of, the Board.

(c) Pursuant to a resolution adopted by the Board, at the Election, there was submitted to the electors of the District, and the electors passed, a proposition (the “**Proposition**”) for the issuance of bonds in an amount not to exceed \$5,500,000 to provide funds to pay the costs of the Project and related costs and to levy an annual tax sufficient to pay the principal of and interest on such bonds as the same become due.

(d) Notice of the Election was published as provided by law, the Election was conducted as provided by law and the results of the Election were as follows:

Ballots cast in favor of bonds and tax	519
Ballots cast against bonds and tax	214

(e) The Board has duly canvassed the returns of the Election and hereby further finds and determines that a majority of all the qualified electors voting on the Proposition voted in favor of the issuance of such bonds and the levy and collection of taxes to pay the same.

(f) The District has not issued any of the bonds authorized at the Election.

(g) It is necessary, desirable, advisable and in the best interest of the District to authorize the issuance, sale and delivery of a portion of the bonds authorized at the Election pursuant to the Act in an aggregate stated principal amount not to exceed \$5,500,000 for the purposes of paying a portion of the costs of the Project and the costs of issuing such bonds. Such bonds may be issued in multiple series on different dates.

(f) All conditions, acts, and things required by law to exist or to be done precedent to the issuance of such bonds do exist and have been done in due form and time as required by law.

Section 2. (a) For the purpose of paying (1) a portion of the costs of the Project and (2) the costs of issuing bonds as described herein, the issuance, sale and delivery of general obligation school bonds of the District, in one or more series, is hereby authorized and directed in an aggregate stated principal amount not to exceed \$5,500,000 (the “**Bonds**”). The Bonds shall be issued in fully registered form in the denomination of \$5,000 or any integral multiple thereof, not exceeding the amount maturing in any one year, and shall be numbered from R-1 upward in the order of their issuance.

(b) The Superintendent and President of the Board (each, an “**Authorized Officer**”) are each hereby authorized and directed, in the exercise of their independent judgment and absolute discretion, to hereafter, from time to time, specify, set, designate, determine, establish and appoint, as the case may be, and in each case in accordance with and subject to the provisions of this Resolution, for each series of the Bonds, (1) the date of original issue of the Bonds, (2) the aggregate stated principal amount of each series of the Bonds to be issued (which shall in no event exceed the stated principal amount of \$5,500,000 in the aggregate), (3) the principal payment dates for the Bonds and the principal amount of Bonds to mature on each of such dates, (4) the date of final maturity of each series of Bonds, which shall in no event be later than during the twentieth year after the date of original issue, (5) the date or dates upon which each series of the Bonds shall be sold, (6) the rate or rates of interest to be carried by each maturity of each series of the Bonds (which shall in no event result in a true interest cost exceeding 7.50% per annum for a series of the Bonds) and any original issue premium or discount, (7) the method by which such rate or rates of interest shall be calculated and the interest payment dates and record date for the Bonds, (8) the date on which the Bonds will be subject to optional redemption, which in no case shall be later than the fifth anniversary of the date of original issue of each series of Bonds, (9) the amount and due date of each sinking fund installment for Bonds that are issued as term Bonds, (10) all of the other terms of the Bonds not otherwise determined or fixed by the provisions of this Resolution, (11) the underwriting discount, not to exceed 1.00%, the price at which the Bonds shall be sold, and the identity of the underwriting firm purchasing the Bonds, as the original purchaser, (the “**Purchaser**”) in consultation with the District’s municipal advisor, (12) the form, contents, terms and provisions of the Bond Purchase Agreement and Registrar Agreement (each as hereinafter defined), (13) whether one or more series, and certain maturities, of the Bonds (such bonds referred to herein as the “**Insured Bonds**”) is to be insured by a bond insurance provider (the “**Bond Insurer**”) as determined pursuant to section 15 of this Resolution and the terms and provisions related to the Bonds and any such bond insurance policy, and (14) the form and contents of any closing and other documentation executed and delivered by the District in connection with the authorization, issuance, sale and delivery of the Bonds.

(c) Payments of interest due on the Bonds prior to maturity or earlier redemption shall be made by the Registrar (hereinafter defined) by mailing a check or draft in the amount due for such interest on each interest payment date to the registered owner of each Bond, as of the record date for such interest payment date, to such owner’s registered address as shown on the books of registration required to be maintained pursuant to **Section 5**. Payment of the principal or redemption price of and interest on any Bond at maturity or earlier redemption shall be made upon presentation and surrender of such Bond as the same shall become due and payable at maturity, upon redemption or otherwise, in lawful money of the United States of America at the office of the Registrar. Notwithstanding the foregoing, Bonds issued in book-entry form shall be paid in accordance with **Section 2(d)**.

(d) The Bonds shall be executed on behalf of the District by the manual or facsimile signatures of the President and Secretary. The Bonds are authorized to initially be issued in book-entry form only using the services of The Depository Trust Company (the “**Depository**”), with one typewritten bond per maturity being issued to the Depository. In such connection such officers are authorized to execute and

deliver a letter of understanding and representation (the “**Representation Letter**”) in the form required by the Depository, for and on behalf of the District, which shall thereafter govern matters with respect to registration, transfer, payment and redemption of the Bonds. Upon the issuance of the Bonds in book entry-form, the following provisions shall apply:

(1) The District and the Registrar shall have no responsibility or obligation to any broker-dealer, bank or other financial institution for which the Depository holds Bonds as securities depository (each, a “**Bond Participant**”) or to any person who is an actual purchaser of a Bond from a Bond Participant while the Bonds are in book-entry form (each, a “**Beneficial Owner**”) with respect to the following:

(A) the accuracy of the records of the Depository, any nominees of the Depository or any Bond Participant with respect to any ownership interest in the Bonds;

(B) the delivery to any Bond Participant, any Beneficial Owner or any other person, other than the Depository, of any notice with respect to the Bonds, including any notice of redemption; or

(C) the payment to any Bond Participant, any Beneficial Owner or any other person, other than the Depository, of any amount with respect to the Bonds. The Registrar shall make payments with respect to the Bonds only to or upon the order of the Depository or its nominee and all such payments shall be valid and effective fully to satisfy and discharge the obligations with respect to such Bonds to the extent of the sum or sums so paid. No person other than the Depository shall receive an authenticated Bond.

(2) Upon receipt by the Registrar of written notice from the Depository to the effect that the Depository is unable or unwilling to discharge its responsibilities, the Registrar shall issue, transfer and exchange Bonds requested by the Depository in appropriate amounts. Whenever the Depository requests the District and the Registrar to do so, the District and the Registrar will cooperate with the Depository in taking appropriate action after reasonable notice (A) to arrange, with the prior written consent of the District, for a substitute depository willing and able upon reasonable and customary terms to maintain custody of the Bonds or (B) to make available Bonds registered in whatever name or names the Beneficial Owners transferring or exchanging such Bonds shall designate.

(3) Subject to any operational requirements of the Depository, if the District determines that it is desirable that certificates representing the Bonds be delivered to the Beneficial Owners of the Bonds and so notifies the Registrar in writing, the Registrar shall so notify the Depository, whereupon the Depository will notify the Bond Participants of the availability through the Depository of certificates representing the Bonds. In such event, the District and the Registrar shall issue, transfer or exchange certificates representing the Bonds as requested by the Depository in appropriate amounts and in authorized denominations.

(4) Notwithstanding any other provision of this Resolution to the contrary, so long as any Bond is registered in the name of the Depository or any nominee thereof, all payments with respect to such Bond and all notices with respect to such Bond shall be made and given, respectively, to the Depository as provided in the Representation Letter.

(5) Registered ownership of the Bonds may be transferred on the books of registration maintained by the Registrar, and the Bonds may be delivered in physical form to the following:

(A) any successor securities depository or its nominee;

(B) any persons, upon (i) the resignation of the Depository from its functions as depository or (ii) termination of the use of the Depository pursuant to this **Section 2**.

(6) In the event of any partial redemption of a Bond, unless and until such partially redeemed Bond has been replaced in accordance with the provisions of this **Section 2**, the books and records of the Registrar shall govern and establish the principal amount of such Bond as is then outstanding and all of the Bonds issued to the Depository or its nominee shall contain a legend to such effect.

If for any reason the Depository resigns and is not replaced, the District shall immediately provide a supply of printed bond certificates, duly executed by the manual or facsimile signatures of the President and Secretary, for issuance upon transfers from the Depository and subsequent transfers or in the event of partial redemption. In the event that such supply of bonds shall be insufficient to meet the requirements of the District and Registrar for issuance of replacement bonds upon transfer or partial redemption, the District agrees to order printed an additional supply of bonds and to direct their execution by the manual or facsimile signature of its then duly qualified and acting President and Secretary. In case any officer whose signature or facsimile thereof shall appear on any Bond shall cease to be such officer before the delivery of such Bond (including any bonds delivered to the Registrar for issuance upon transfer), such signature or such facsimile signature shall nevertheless be valid and sufficient for all purposes the same as if such officer or officers had remained in office until the delivery of such Bond. No Bond shall be valid or obligatory for any purpose or entitled to any security or benefit under this Resolution unless and until the Certificate of Authentication thereon shall have been duly executed by the Registrar. Certificates of Authentication on different Bonds need not be signed by the same representative. The executed Certificate of Authentication on each Bond shall be conclusive evidence that it has been authenticated and delivered under this Resolution.

(e) Any Bond issued upon transfer or exchange thereof shall be dated as of the date of original issue of such Bond or the interest payment date six months preceding the interest payment date next following the date of registration thereof in the office of the Registrar, as shall be appropriate, unless such date of registration shall be an interest payment date, in which case they shall be dated as of such date of registration; provided, however, that if, as shown by the records of the Registrar, interest on such Bond shall be in default, the Bond issued in lieu thereof may be dated as of the date to which interest has been paid in full on such surrendered Bond; and provided further, that if the date of registration shall be prior to the first interest payment date, such Bond shall be dated as of the date of original issue thereof. The Bonds shall bear interest from the date of original issue thereof.

(f) When any Bond shall have been duly called for redemption and payment thereof duly made or provided for, interest thereon shall cease from and after the date specified for the redemption thereof.

(g) Both the principal of and interest on the Bonds shall be payable at the office of the Registrar in any coin or currency of the United States of America which at the time of such payment is legal tender for public and private debts.

(h) If the date for payment of the principal of or interest on the Bonds shall be a Saturday, Sunday, legal holiday or a day on which banking institutions in the city where the principal corporate trust office of the Registrar is located are authorized by law or executive order to close, then the date for such payment shall be the next succeeding day which is not a Saturday, Sunday, legal holiday or a day on which such banking institutions are authorized to close, and payment on such day shall have the same force and effect as if made on the nominal date of payment.

(i) An Authorized Officer, in her or his discretion, may authorize the printing of CUSIP identification numbers on the Bonds. In the event such numbers are imprinted on the Bonds, no such number shall constitute a part of the contract evidenced by the particular Bond upon which it is imprinted, and no liability shall be attached to the District, or to any officer or agent thereof, including the Registrar, by reason of such numbers or any use made thereof, including any use thereof made by the District, any such officer, the Registrar, or by reason of any inaccuracy, error or omission with respect thereto or in such use.

(j) The Bonds, registration provisions, form of authentication and form of assignment pertaining thereto shall be substantially in the forms set forth below with such changes as may be determined upon by an Authorized Officer and such other necessary or appropriate variations, omissions and insertions as are incidental to numbering, denominations, interest rate or rates, registration provisions, redemption provisions and other details thereof or as are otherwise permitted or required by law or this Resolution.

(k) In the event that payments of interest due on the Bonds on an interest payment date are not timely made, such interest shall cease to be payable to the registered owners as of the record date for such interest payment date and shall be payable to the registered owners of the Bonds as of a special date of record for payment of such defaulted interest as shall be designated by the Registrar whenever money for the purpose of paying such defaulted interest becomes available.

(l) The Bonds shall be in substantially the following form:

[FORM OF BONDS]

UNITED STATES OF AMERICA
STATE OF NEBRASKA
COUNTY OF BUFFALO

GENERAL OBLIGATION BOND, SERIES 2025
OF BUFFALO COUNTY SCHOOL DISTRICT 0069
(RAVENNA PUBLIC SCHOOLS)

No. R- _____ \$
Interest Rate Maturity Date Date of Original Issue CUSIP
% , 20__ , 2025

Registered Owner: Cede & Co.
13-2555119

Principal Amount:

KNOW ALL PERSONS BY THESE PRESENTS: That Buffalo County School District 0069, in the State of Nebraska, hereby acknowledges itself to owe and for value received promises to pay to the registered owner specified above, or registered assigns, the principal amount specified above in lawful money of the United States of America on the date of maturity specified above with interest thereon to maturity (or earlier redemption) from the date of original issue shown above or most recent Interest Payment Date, whichever is later, at the rate per annum specified above, payable on _____, 20__ and semiannually thereafter on _____ and _____ of each year (each, an "Interest Payment Date"). Said interest shall be computed on the basis of a 360-day year consisting of twelve 30-day months. The principal of this bond, together with unpaid accrued interest due at maturity or upon earlier redemption, is payable upon presentation and surrender of this bond at the principal corporate trust office of _____, the Paying Agent and Registrar in _____, Nebraska. Interest on this bond due prior to maturity or earlier redemption will be paid on each Interest Payment Date by a check or draft mailed on such Interest Payment Date by the Paying Agent and Registrar to the registered owner of this bond, as shown on the books of record maintained by the Paying Agent and Registrar, at the close of business on the fifteenth day immediately preceding the Interest Payment Date, to such owner's address as shown on such books and records. Any interest not so timely paid shall cease to be payable to the person entitled thereto as of the record date such interest was payable and shall be payable to the person who is the registered owner of this bond (or of one or more predecessor bonds hereto) on such special record date for payment of such defaulted interest as shall be fixed by the Paying Agent and Registrar whenever monies for such purpose become available. For the prompt payment of this bond, both principal and interest, as the same become due, the full faith, credit and resources of said District are hereby irrevocably pledged.

This bond is one of an issue of fully registered bonds of the total principal amount of _____ Dollars (\$ _____), of even date and like tenor herewith, except as to date of maturity and rate of interest and denomination, which were issued by said District for the purpose of paying a portion of the costs of to pay the costs of constructing additions, renovations and improvements to the District's existing school buildings and facilities, and providing necessary equipment and apparatus for such buildings and facilities under the authority of and in full compliance with the constitution and laws of the State of Nebraska, and pursuant to an election duly held in the District on March 11, 2025, and a resolution duly passed (the "Resolution") and proceedings duly and legally had by the President and Board of the District.

Any or all of the bonds are subject to redemption at the option of the District prior to the stated maturities thereof, in whole or in part, at any time on or after _____, 20__, at par plus the interest

accrued on the principal amount being redeemed to the date fixed for redemption. Notice of redemption shall be given by mail to the registered owner of any bond to be redeemed in the manner specified in the Resolution authorizing said issue of bonds. Individual bonds shall be redeemed in part but only in the amount of \$5,000 or integral multiples thereof.

This bond is transferable by the registered owner or such owner's attorney duly authorized in writing at the principal corporate trust office of the Paying Agent and Registrar in _____, Nebraska, upon surrender and cancellation of this bond, and thereupon a new bond or bonds of the same aggregate principal amount, interest rate and maturity will be issued to the transferee as provided in the Resolution authorizing said issue of bonds, subject to the limitations therein prescribed. The District, the Paying Agent and Registrar and any other person may treat the person in whose name this bond is registered as the absolute owner hereof for the purpose of receiving payment due hereunder and for all purposes and shall not be affected by any notice to the contrary, whether this bond be overdue or not.

If the date for payment of the principal of or interest on this bond shall be a Saturday, Sunday, legal holiday or a day on which banking institutions in the Board of Education where the principal corporate trust office of the Paying Agent and Registrar is located are authorized by law or executive order to close, then the date for such payment shall be the next succeeding day which is not a Saturday, Sunday, legal holiday or a day on which such banking institutions are authorized to close, and payment on such date shall have the same force and effect as if made on the nominal date of payment.

AS PROVIDED IN THE RESOLUTION REFERRED TO HEREIN, UNTIL THE TERMINATION OF THE SYSTEM OF BOOK-ENTRY-ONLY TRANSFERS THROUGH THE DEPOSITORY TRUST COMPANY, NEW YORK, NEW YORK (TOGETHER WITH ANY SUCCESSOR SECURITIES DEPOSITORY APPOINTED PURSUANT TO THE RESOLUTION, "DTC"), AND NOTWITHSTANDING ANY OTHER PROVISIONS OF THE RESOLUTION TO THE CONTRARY, A PORTION OF THE PRINCIPAL AMOUNT OF THIS BOND MAY BE PAID OR REDEEMED WITHOUT SURRENDER HEREOF TO THE REGISTRAR. DTC OR A NOMINEE, TRANSFEREE OR ASSIGNEE OF DTC OF THIS BOND MAY NOT RELY UPON THE PRINCIPAL AMOUNT INDICATED HEREON AS THE PRINCIPAL AMOUNT HEREOF OUTSTANDING AND UNPAID. THE PRINCIPAL AMOUNT HEREOF OUTSTANDING AND UNPAID SHALL FOR ALL PURPOSES BE THE AMOUNT DETERMINED IN THE MANNER PROVIDED IN THE RESOLUTION.

UNLESS THIS BOND IS PRESENTED BY AN AUTHORIZED OFFICER OF DTC (A) TO THE REGISTRAR FOR REGISTRATION OF TRANSFER OR EXCHANGE OR (B) TO THE REGISTRAR FOR PAYMENT OF PRINCIPAL, AND ANY BOND ISSUED IN REPLACEMENT HEREOF OR SUBSTITUTION HEREFOR IS REGISTERED IN THE NAME OF DTC AND ANY PAYMENT IS MADE TO DTC OR ITS NOMINEE, ANY TRANSFER, PLEDGE OR OTHER USE HEREOF FOR VALUE OR OTHERWISE BY OR TO ANY PERSON IS WRONGFUL BECAUSE ONLY THE REGISTERED OWNER HEREOF, DTC OR ITS NOMINEE, HAS AN INTEREST HEREIN.

IT IS HEREBY CERTIFIED AND WARRANTED that all conditions, acts and things required by law to exist or to be done precedent to and in the issuance of this bond did exist, did happen, and were done and performed in regular and due form and time as required by law, and that the indebtedness of the District, including this bond, does not exceed any limitation imposed by law. The District agrees that it shall cause to be made annually, in addition to all other taxes, a special levy of taxes for the purpose of paying and sufficient to pay in full the principal of and interest on this bond and the bonds of this issue as and when such principal and interest respectively become due.

This bond shall not be valid and binding on the District until authenticated by the Paying Agent and Registrar.

IN WITNESS WHEREOF, the Board of Education of the District has caused this bond to be executed on behalf of the District with the facsimile signatures of the President and the Secretary of said Board, all as of the date of original issue shown above.

BUFFALO COUNTY SCHOOL DISTRICT
0069 (RAVENNA PUBLIC SCHOOLS), IN THE
STATE OF NEBRASKA

ATTEST:

(facsimile signature)
President

(facsimile signature)
Secretary

CERTIFICATE OF AUTHENTICATION

This bond is one of the bonds authorized by resolution of the Board of Education of Buffalo County School District 0069, in the State of Nebraska, as described in the foregoing bond.

_____, NEBRASKA
Paying Agent and Registrar

By _____
Authorized Signature

[STATEMENT OF INSURANCE TO BE ADDED IF BOND INSURANCE IS PURCHASED]

(FORM OF ASSIGNMENT)

FOR VALUE RECEIVED, the undersigned hereby sells, assigns and transfers unto

Print or Type Name, Address and Social Security Number
or other Taxpayer Identification Number of Transferee

the within Bond and all rights thereunder, and hereby irrevocably constitutes and appoints _____ agent to transfer the within Bond on the Bond Register kept by the Paying Agent for the registration thereof, with full power of substitution in the premises.

Dated: _____

NOTICE: The signature to this assignment must correspond with the name of the Registered Owner as it appears upon the face of the within Bond in every particular.

Medallion Signature Guarantee:

Section 3. The Board hereby represents, covenants, and warrants that it shall, for so long as any Bond remains outstanding, annually provide for the levy and collection of a tax in addition to all other taxes upon all of the taxable property in the District sufficient in rate and amount to pay the principal or redemption price of and interest on the Bonds as the same becomes due and payable.

Section 4. The Authorized Officers are each hereby authorized to designate a paying agent and registrar for the bonds to serve as the (a) paying agent for the payment of principal of and interest on the Bonds and (b) bond registrar with respect to the registration, transfer and exchange of Bonds (the “**Registrar**”). The District is authorized to enter into the Bond Registrar and Paying Agent Agreement (the “**Registrar Agreement**”) dated the date of its execution and delivery for each series of Bonds between the District and the Paying Agent in substantially the form determined by an Authorized Officer in accordance with the provisions of **Section 2(b)** (a copy of which shall be filed in the records of the District). An Authorized Officer is authorized to execute the Registrar Agreement with such changes therein as such official deems appropriate, for and on behalf of and as the act and deed of the District.

The District will at all times maintain a Paying Agent meeting the qualifications herein described for the performance of the duties hereunder. The District reserves the right to appoint a successor Paying Agent by (1) filing with the bank or trust company then performing such function a certified copy of the proceedings giving notice of the termination of such bank or trust company and appointing a successor, and (2) causing notice to be given by first class mail to each registered owner. No resignation or removal of the Paying Agent shall become effective until a successor has been appointed and has accepted the duties of the Paying Agent.

Each Paying Agent appointed hereunder shall at all times be a commercial banking association or corporation or trust company organized and in good standing and doing business under the laws of the United States of America or of the State of Nebraska, authorized under such laws to exercise trust powers and subject to supervision or examination by federal or state regulatory authority.

The Paying Agent shall be paid the usual fees and expenses for its services in connection therewith.

Section 5. As long as any of the Bonds remain outstanding, the District shall maintain and keep at the office of the Registrar an office or agency for the payment of the principal or redemption price of and interest on the Bonds, and for the registration and transfer of the Bonds, and shall also keep at such office of the Registrar books for such registration and transfer.

Upon surrender for transfer of any fully registered Bond at the office of the Registrar with a written instrument of transfer satisfactory to the Registrar, duly executed by the registered owner or its duly authorized attorney, and upon payment of any tax, fee or other governmental charge required to be paid with respect to such transfer, the District shall execute and the Registrar shall authenticate and deliver, in the name of the designated transferee(s), one or more fully registered Bonds of any authorized denominations and of a like aggregate principal amount, interest rate and maturity.

Except as the right of exchange may be limited by an Authorized Officer, Bonds may, upon surrender thereof at the office of the Registrar, at the option of the registered owner thereof, be exchanged for an equal aggregate principal amount of Bonds of the same maturity and interest rate of any authorized denominations.

In all cases in which the privilege of exchanging Bonds or transferring Bonds is exercised, the District shall execute and the Registrar shall deliver Bonds in accordance with the provisions of this Resolution. For every such exchange or transfer of Bonds, whether temporary or definitive, the District or the Registrar may make a charge sufficient to reimburse it for any tax, fee or other governmental charge

required to be paid with respect to such exchange or transfer, which sum(s) shall be paid by the person requesting such exchange or transfer as a condition precedent to the exercise of the privilege of making such exchange or transfer. The District shall not be obligated to make any such exchange or transfer of Bonds during the 15 days next preceding the date of the first publication or the mailing (if there is no publication) of notice of redemption in the case of a proposed redemption of Bonds. The District and the Registrar shall not be required to make any transfer or exchange of any Bonds called for redemption.

As to any Bond, the person in whose name the same shall be registered shall be deemed and regarded as the absolute owner thereof for all purposes, and the payment of or on account of the principal or redemption price of and the interest on any such Bond shall be made only to or upon the order of the registered owner thereof or its legal representative. All such payments shall be valid and effectual to satisfy and discharge the liability upon such Bond, including the interest thereon, to the extent of the sum(s) so paid.

Section 6. (a) An Authorized Officer is hereby authorized to enter into a Bond Purchase Agreement between the District and the Purchaser under which the District agrees to sell the Bonds to the Purchaser, upon the terms and conditions set forth therein and with such changes therein as shall be approved by an Authorized Officer, which officer is hereby authorized to execute the Bond Purchase Agreement for and on behalf of the District, such officer's signature thereon being conclusive evidence of his or her approval thereof (the "**Bond Purchase Agreement**"). An Authorized Officer shall be responsible for delivery of the Bonds and for all other ministerial acts relating to the Bonds. Each Authorized Officer and all other officers of the Board are hereby authorized to take all actions subsequent to the sale of the Bonds in accordance with the provisions of this Resolution as may be required for the delivery of the Bonds to the Purchaser thereof. An Authorized Officer is also hereby authorized to approve such documents and certificates as determined appropriate and necessary if the bonds are sold in a private placement without use of the Depository. Such officials are hereby authorized to execute such orders, certificates, receipts and other documents as may be necessary or desirable for delivery and to receive the purchase price for the Bonds.

(b) The proceeds received from the sale of the Bonds, including the accrued interest thereon, if any, on the Bonds from the date of original issuance thereof to the date of delivery and payment therefor, shall be received by an Authorized Officer, who shall deposit the proceeds thereof into the "Construction Fund," which is hereby established and created. Amounts on deposit in the "Construction Fund" shall be expended from time to time in order to pay costs and expenses incurred by the District in connection with the Project, which may include costs of issuance of the Bonds.

Section 7. The District's obligations under this Resolution shall be fully discharged and satisfied as to any Bond authorized and issued hereunder, and such Bond shall no longer be deemed outstanding hereunder when payment of the principal or redemption price thereof and accrued interest thereon to the date of maturity or redemption (a) shall have been made, or caused to have been made, in accordance with the terms thereof; or (b) shall have been provided for by depositing with the Registrar, or in escrow with a national or state bank having trust powers in trust solely for such payment of such Bond (1) sufficient money to make such payments; or (2) direct general obligations of, or obligations the principal of and interest on which are unconditionally guaranteed by, the United States of America (herein referred to as "**Government Obligations**"), in such amounts and with such maturities as to principal and interest as will insure the availability of sufficient money to make such payments, and such Bond shall thereupon cease to draw interest from the date fixed for its redemption or maturity and, except for the purposes of such payment, shall no longer be entitled to the benefits of this Resolution; provided that with respect to any Bond called or to be called for redemption prior to the stated maturity thereof, notice of redemption shall have been duly given. If money or Government Obligations shall have been deposited in accordance with the terms hereof with the Registrar or escrow agent in trust for that purpose sufficient to pay the principal

or redemption price of or interest on any Bond to the date of maturity or redemption, all liability of the District for such payment shall forthwith cease, determine and be completely discharged, and such Bond shall no longer be considered outstanding.

Section 8. The preparation, use, distribution and delivery of a Preliminary Official Statement and an Official Statement or other offering materials of the District in such forms and of such contents as an Authorized Officer shall, in the exercise of her or his independent judgment and absolute discretion determine to be necessary, proper, appropriate, advisable or desirable in order to effectuate the issuance, sale and delivery of the Bonds is hereby in all respects, authorized, directed, adopted, specified, accepted, ratified, approved and confirmed. An Authorized Officer shall deem any such offering materials as final for purposes of Rule 15c2-12 promulgated under the Securities and Exchange Act of 1934, as amended.

Section 9. The District hereby (a) authorizes and directs that an Authorized Officer execute and deliver, on the date of issue of the Bonds, a continuing disclosure undertaking (the “Continuing Disclosure Undertaking”) in such form as shall be satisfactory to the District and in compliance with Rule 15c2-12 of the Securities and Exchange Commission, and (b) covenants and agrees that it will comply with and carry out all of the provisions of the Continuing Disclosure Undertaking. Notwithstanding any other provision of this Resolution, failure of the District to comply with the Continuing Disclosure Undertaking shall not be considered an event of default hereunder; however, any Participating Underwriter (as such term is defined in the Continuing Disclosure Undertaking) or any Beneficial Owner or any Registered Owner of a Bond (as such terms are defined in the Continuing Disclosure Undertaking) may take such actions as may be necessary and appropriate, including seeking mandamus or specific performance by court order, to cause the District to comply with its obligations under this section.

Section 10. All actions heretofore taken by an Authorized Officer and all other officers, officials, employees and agents of the District, including without limitation the expenditure of funds and the selection, appointment and employment of bond counsel and financial advisors and agents, in connection with issuance and sale of the Bonds, together with all other actions taken in connection with any of the matters which are the subject hereof, are in all respects authorized, adopted, specified, accepted, ratified, approved and confirmed.

Section 11. Without in any way limiting the power, authority or discretion elsewhere herein granted or delegated, the Board hereby (a) authorizes and directs each Authorized Officer and all other officers, officials, employees and agents of the District to carry out or cause to be carried out, and to perform such obligations of the District and such other actions as they, or any of them, in consultation with bond counsel, the Purchaser of the Bonds and its or their counsel, shall consider necessary, advisable, desirable or appropriate in connection with this Resolution, any Preliminary Official Statement and any Official Statement and other offering materials of the District used in connection with issuance, sale and delivery of the Bonds, including without limitation and whenever appropriate the execution and delivery thereof and of all other related documents, instruments, certifications and opinions, and (b) delegates, authorizes and directs each Authorized Officer the right, power and authority to exercise her or his independent judgment and absolute discretion in (1) determining and finalizing all other terms and provisions to be carried by the Bonds not specifically set forth in this Resolution and (2) the taking of all actions and the making of all arrangements necessary, proper, appropriate, advisable or desirable in order to effectuate the issuance, sale and delivery of the Bonds. The execution and delivery by an Authorized Officer or by any such other officers, officials, employees or agents of the District of any such documents, instruments, certifications and opinions, or the doing by them of any act in connection with any of the matters which are the subject of this Resolution, shall constitute conclusive evidence of both the District’s and their approval of the terms, provisions and contents thereof and of all changes, modifications, amendments, revisions and alterations made therein and shall conclusively establish their absolute, unconditional and irrevocable authority with

respect thereto from the District and the authorization, approval and ratification by the District of the documents, instruments, certifications and opinions so executed and the actions so taken.

Section 12. (a) The District covenants and agrees that (1) it will comply with all applicable provisions of the Internal Revenue Code of 1986, as amended (the “Code”), including Sections 103 and 141 through 150, necessary to maintain the exclusion from gross income for federal income tax purposes of the interest on the Bonds, and (2) it will not use or permit the use of any proceeds of the Bonds or any other funds of the District, nor take or permit any other action, or fail to take any action, which would adversely affect the exclusion from gross income of the interest on the Bonds. The District will also adopt such other resolutions and take such other actions as may be necessary to comply with the Code and with other applicable future laws, in order to ensure that the interest on the Bonds will remain excluded from gross income for federal income tax purposes, to the extent any such actions can be taken by the District.

(b) The District covenants that (1) it will comply with all requirements of Section 148 of the Code to the extent applicable to the Bonds, (2) it will use the proceeds of the Bonds as soon as practicable and with all reasonable dispatch for the purposes for which the Bonds are issued, and (3) it will not invest or directly or indirectly use or permit the use of any proceeds of the Bonds or any other funds of the District in any manner, or take or omit to take any action, that would cause any Bond to be an “arbitrage bond” within the meaning of Section 148(a) of the Code. An Authorized Officer is hereby authorized to make any certifications, covenants and designations with respect to status of the Bonds under Section 265 of the Code as he or she deems appropriate.

(c) The District covenants that it will pay or provide for the payment from time to time of all arbitrage rebate to the United States of America pursuant to Section 148(f) of the Code and any United States Treasury Regulations applicable to the Bonds from time to time. This covenant shall survive payment in full or defeasance of the Bonds. The District specifically covenants to pay or cause to be paid to the United States of America, the required amounts of arbitrage rebate at the times and in the amounts specified in the Federal Tax Certificate executed and delivered by the District in connection with the issuance of the Bonds (the “Tax Certificate”). The Tax Certificate may be amended or replaced if, in the opinion of nationally recognized bond counsel, such amendment or replacement will not adversely affect the exclusion from gross income for federal income tax purposes of the interest on any Bond.

(d) The District covenants that it will not use any portion of the proceeds of the Bonds, including any investment income earned on such proceeds, directly or indirectly, (1) in a manner that would cause the Bonds to be “private activity bonds” within the meaning of Section 141(a) of the Code, or (2) to make or finance a loan to any non-governmental entity.

Section 13. Rebate Account. To ensure proper compliance with the tax covenants contained in **Section 12**, the District shall establish and an Authorized Officer shall maintain one or more accounts separate from any other fund or account established and maintained hereunder appropriately designated as the 2021 Rebate Account. All money at any time deposited in any Rebate Account in accordance with the provisions of a Tax Certificate shall be held for the account of the District in trust for payment to the federal government of the United States of America, and neither the District nor any registered owner of any Bond shall have any rights in or claim to such money. All amounts deposited into or on deposit in any Rebate Account shall be governed hereby and by the related Tax Certificate. The District shall invest all amounts held in any Rebate Account in accordance with the related Tax Certificate. Money shall not be transferred from a Rebate Account except in accordance with the related Tax Certificate.

Section 14. The Secretary is directed to make and certify transcripts of the proceedings of the District precedent to the issuance of such Bonds, a copy of which shall be delivered to the original purchaser of the Bonds.

Section 15. The Authorized Officers are authorized to enter into an insurance policy (the “Bond Insurance Policy”) issued by the Bond Insurer guaranteeing the scheduled payment of the principal of and interest on the Insured Bonds. If any terms or provisions governing the Bonds are required by a Bond Insurer as a condition of issuing the Bond Insurance Policy with respect to any Insured Bonds, the Authorized Officers are hereby authorized to provide covenants and agreements to satisfy such requirements of the Bond Insurer in a supplemental certificate signed by each of the Superintendent of the District and President of the Board (the “**Bond Insurance Provisions**”). Such Bond Insurance Provisions shall govern the terms of the applicable Insured Bonds, notwithstanding any other provision of this Resolution to the contrary.

Section 16. Without limiting the generality of Section 15, and without specifying the identity of any Bond Insurer, the following Bond Insurance Provisions shall be applicable to any bonds designated as Insured Bonds when the Bond Insurer is Assured Guaranty, Inc.:

(a) As used in this Section 16, “**Insurer**” shall be defined as follows: “Assured Guaranty, Inc., a New York stock insurance company, or any successor thereto or assignee thereof”. “**Policy**” shall be defined as follows: “the insurance policy issued by the Insurer guaranteeing the scheduled payment of principal of and interest on the Bonds when due”. Other capitalized terms used in this Section 16 but not otherwise defined shall have the meanings ascribed to them elsewhere in this Resolution.

(b) The Insurer shall be deemed to be the sole holder of Bonds designated as Insured Bonds for the purpose of exercising any voting right or privilege or giving any consent or direction or taking any other action that the holders of the Insured Bonds are entitled to take pursuant to the Bond Resolution pertaining to (i) defaults and remedies and (ii) the duties and obligations of the Registrar. In furtherance thereof and as a term of this Bond Resolution and each Insured Bond, the Registrar and each holder of the Insured Bonds appoint the Insurer as their agent and attorney-in-fact with respect to the Insured Bonds and agree that the Insurer may at any time during the continuation of any proceeding by or against the District under the United States Bankruptcy Code or any other applicable bankruptcy, insolvency, receivership, rehabilitation or similar law (an “**Insolvency Proceeding**”) direct all matters relating to such Insolvency Proceeding, including without limitation, (A) all matters relating to any claim or enforcement proceeding in connection with an Insolvency Proceeding (a “**Claim**”), (B) the direction of any appeal of any order relating to any Claim, (C) the posting of any surety, supersedeas or performance bond pending any such appeal, and (D) the right to vote to accept or reject any plan of adjustment. In addition, the Registrar and each holder of the Insured Bonds delegate and assign to the Insurer, to the fullest extent permitted by law, the rights of the Registrar and each holder of the Insured Bonds in the conduct of any Insolvency Proceeding, including, without limitation, all rights of any party to an adversary proceeding or action with respect to any court order issued in connection with any such Insolvency Proceeding. Remedies granted to the holders shall expressly include mandamus.

(c) The maturity of the Insured Bonds shall not be accelerated without the consent of the Insurer and in the event the maturity of the Insured Bonds is accelerated, the Insurer may elect, in its sole discretion, to pay accelerated principal and interest accrued, on such principal to the date of acceleration (to the extent unpaid by the District) and the Registrar shall be required to accept such amounts. Upon payment of such accelerated principal and interest accrued to the acceleration date as provided above, the Insurer’s obligations under the Policy with respect to such Insured Bonds shall be fully discharged.

(d) No grace period for a covenant default shall exceed 30 days or be extended for more than 60 days, without the prior written consent of the Insurer. No grace period shall be permitted for payment defaults.

(e) The Insurer is a third party beneficiary to this Bond Resolution.

(f) Any amendment, supplement, modification to, or waiver of, the Bond Resolution or any other transaction document, including any underlying security agreement (each a “**Related Document**”), that requires the consent of holders or adversely affects the rights and interests of the Insurer shall be subject to the prior written consent of the Insurer.

(g) The rights granted to the Insurer under the Bond Resolution or any other Related Document to request, consent to or direct any action are rights granted to the Insurer in consideration of its issuance of the Policy. Any exercise by the Insurer of such rights is merely an exercise of the Insurer’s contractual rights and shall not be construed or deemed to be taken for the benefit, or on behalf, of the holders and such action does not evidence any position of the Insurer, affirmative or negative, as to whether the consent of the holders or any other person is required in addition to the consent of the Insurer.

(h) Only (1) cash, (2) non-callable direct obligations of the United States of America (“**Treasuries**”), (3) evidences of ownership of proportionate interests in future interest and principal payments on Treasuries held by a bank or trust company as custodian, under which the owner of the investment is the real party in interest and has the right to proceed directly and individually against the obligor and the underlying Treasuries are not available to any person claiming through the custodian or to whom the custodian may be obligated, (4) subject to the prior written consent of the Insurer, pre-refunded municipal obligations rated “AAA” and “Aaa” by S&P and Moody’s, respectively, or (5) subject to the prior written consent of the Insurer, securities eligible for “AAA” defeasance under then existing criteria of S&P or any combination thereof, shall be used to effect defeasance of the Insured Bonds unless the Insurer otherwise approves.

To accomplish defeasance of the Insured Bonds, the District shall cause to be delivered (i) a report of an independent firm of nationally recognized certified public accountants or such other accountant as shall be acceptable to the Insurer (“**Accountant**”) verifying the sufficiency of the escrow established to pay the Insured Bonds in full on the maturity or redemption date (“**Verification**”), (ii) an Escrow Deposit Agreement (which shall be acceptable in form and substance to the Insurer), (iii) an opinion of nationally recognized bond counsel to the effect that the Insured Bonds are no longer “Outstanding” under the Bond Resolution and (iv) a certificate of discharge of the Registrar with respect to the Insured Bonds; each Verification and defeasance opinion shall be acceptable in form and substance, and addressed, to the District, the Registrar and the Insurer. The Insurer shall be provided with final drafts of the above-referenced documentation not less than five business days prior to the funding of the escrow.

Insured Bonds shall be deemed “Outstanding” under the Bond Resolution unless and until they are in fact paid and retired or the above criteria are met.

(i) Amounts paid by the Insurer under the Policy shall not be deemed paid for purposes of the Bond Resolution and the Insured Bonds relating to such payments shall remain Outstanding and continue to be due and owing until paid by the District in accordance with the Bond Resolution. The Bond Resolution shall not be discharged unless all amounts due or to become due to the Insurer have been paid in full or duly provided for.

(j) Claims Upon the Policy and Payments by and to the Insurer.

If, on the third Business Day prior to the related scheduled interest payment date or principal payment date (“**Payment Date**”) there is not on deposit with the Registrar, after making all transfers and deposits required under the Bond Resolution, moneys sufficient to pay the principal of and interest on the Insured Bonds due on such Payment Date, the Registrar shall give notice to the Insurer and to its designated agent (if any) (the “**Insurer’s Fiscal Agent**”) by telephone or teletype of the amount of such deficiency by 12:00 noon, New York City time, on such Business Day. If, on the second Business Day prior to the related Payment Date, there continues to be a deficiency in the amount available to pay the principal of and interest on the Insured Bonds due on such Payment Date, the Registrar shall make a claim under the Policy and give notice to the Insurer and the Insurer’s Fiscal Agent (if any) by telephone of the amount of such deficiency, and the allocation of such deficiency between the amount required to pay interest on the Insured Bonds and the amount required to pay principal of the Insured Bonds, confirmed in writing to the Insurer and the Insurer’s Fiscal Agent by 12:00 noon, New York City time, on such second Business Day by filling in the form of Notice of Claim and Certificate delivered with the Policy.

The Registrar shall designate any portion of payment of principal on Insured Bonds paid by the Insurer, whether by virtue of mandatory sinking fund redemption, maturity or other advancement of maturity, on its books as a reduction in the principal amount of Insured Bonds registered to the then current holder of the Insured Bonds, whether DTC or its nominee or otherwise, and shall issue a replacement Bond to the Insurer, registered in the name of Assured Guaranty, Inc., in a principal amount equal to the amount of principal so paid (without regard to authorized denominations); provided that the Registrar’s failure to so designate any payment or issue any replacement Bond shall have no effect on the amount of principal or interest payable by the District on any Bond or the subrogation rights of the Insurer.

The Registrar shall keep a complete and accurate record of all funds deposited by the Insurer into the Policy Payments Account (defined below) and the allocation of such funds to payment of interest on and principal of any Insured Bond. The Insurer shall have the right to inspect such records at reasonable times upon reasonable notice to the Registrar.

Upon payment of a claim under the Policy, the Registrar shall establish a separate special purpose trust account for the benefit of holders of the Insured Bonds referred to herein as the “**Policy Payments Account**” and over which the Registrar shall have exclusive control and sole right of withdrawal. The Registrar shall receive any amount paid under the Policy in trust on behalf of holders of the Insured Bonds and shall deposit any such amount in the Policy Payments Account and distribute such amount only for purposes of making the payments for which a claim was made. Such amounts shall be disbursed by the Registrar to holders of the Insured Bonds in the same manner as principal and interest payments are to be made with respect to the Insured Bonds under the sections hereof regarding payment of Insured Bonds. It shall not be necessary for such payments to be made by checks or wire transfers separate from the check or wire transfer used to pay debt service with other funds available to make such payments. Notwithstanding anything in the Indenture to the contrary, the District agrees to pay to the Insurer (i) a sum equal to the total of all amounts paid by the Insurer under the Policy (the “**Insurer Advances**”); and (ii) interest on such Insurer Advances from the date paid by the Insurer until payment thereof in full, payable to the Insurer at the Late Payment Rate per annum (collectively, the “**Insurer Reimbursement Amounts**”). “**Late Payment Rate**” means the lesser of (a) the greater of (i) the per annum rate of interest, publicly announced from time to time by JPMorgan Chase Bank at its principal office in The City of New York, as its prime or base lending rate (any change in such rate of interest to be effective on the date such change is announced by JPMorgan Chase Bank) plus 3%, and (ii) the then applicable highest rate of interest

on the Insured Bonds and (b) the maximum rate permissible under applicable usury or similar laws limiting interest rates. The Late Payment Rate shall be computed on the basis of the actual number of days elapsed over a year of 360 days. The District hereby covenants and agrees that the Insurer Reimbursement Amounts are secured by a lien on and pledge of the Revenues and payable from such Revenues on a parity with debt service due on the Insured Bonds.

Funds held in the Policy Payments Account shall not be invested by the Registrar and may not be applied to satisfy any costs, expenses or liabilities of the Registrar. Any funds remaining in the Policy Payments Account following a Payment Date shall promptly be remitted to the Insurer.

(k) The Insurer shall, to the extent it makes any payment of principal of or interest on the Insured Bonds, become subrogated to the rights of the recipients of such payments in accordance with the terms of the Policy (which subrogation rights shall also include the rights of any such recipients in connection with any Insolvency Proceeding). Each obligation of the District to the Insurer under the Related Documents shall survive discharge or termination of such Related Documents.

(l) The District shall pay or reimburse the Insurer any and all charges, fees, costs and expenses that the Insurer may reasonably pay or incur in connection with (i) the administration, enforcement, defense or preservation of any rights or security in any Related Document; (ii) the pursuit of any remedies under the Bond Resolution or any other Related Document or otherwise afforded by law or equity, (iii) any amendment, waiver or other action with respect to, or related to, the Bond Resolution or any other Related Document whether or not executed or completed, or (iv) any litigation or other dispute in connection with the Bond Resolution or any other Related Document or the transactions contemplated thereby, other than costs resulting from the failure of the Insurer to honor its obligations under the Policy. The Insurer reserves the right to charge a reasonable fee as a condition to executing any amendment, waiver or consent proposed in respect of the Bond Resolution or any other Related Document.

(m) The Insurer shall be entitled to pay principal or interest on the Insured Bonds that shall become Due for Payment but shall be unpaid by reason of Nonpayment by the District (as such terms are defined in the Policy) and any amounts due on the Insured Bonds as a result of acceleration of the maturity thereof in accordance with the Bond Resolution, whether or not the Insurer has received a Notice of Nonpayment (as such terms are defined in the Policy) or a claim upon the Policy.

(n) The notice address of the Insurer is: Assured Guaranty, Inc., 1633 Broadway, New York, New York 10019, Attention: Managing Director – Surveillance, Re: Policy No. _____, Telephone: (212) 974-0100; Telecopier: (212) 339-3556. In each case in which notice or other communication refers to an Event of Default, then a copy of such notice or other communication shall also be sent to the attention of the General Counsel and shall be marked to indicate “URGENT MATERIAL ENCLOSED.”

(o) The Insurer shall be provided with the following information by the District or the Registrar, as the case may be:

(i) Annual audited financial statements within 180 days after the end of the District’s fiscal year (together with a certification of the District that it is not aware of any default or Event of Default under the Bond Resolution), and the District’s annual budget within 30 days after the approval thereof together with such other information, data or reports as the Insurer shall reasonably request from time to time;

- (ii) Notice of any draw upon the Reserve Fund within two Business Days after knowledge thereof other than (i) withdrawals of amounts in excess of the Maximum Required Reserve and (ii) withdrawals in connection with a refunding of Insured Bonds;
- (iii) Notice of any default known to the Registrar or District within five Business Days after knowledge thereof;
- (iv) Prior notice of the advance refunding or redemption of any of the Insured Bonds, including the principal amount, maturities and CUSIP numbers thereof;
- (v) Notice of the resignation or removal of the Registrar and the appointment of, and acceptance of duties by, any successor thereto;
- (vi) Notice of the commencement of any Insolvency Proceeding;
- (vii) Notice of the making of any claim in connection with any Insolvency Proceeding seeking the avoidance as a preferential transfer of any payment of principal of, or interest on, the Insured Bonds;
- (viii) A full original transcript of all proceedings relating to the execution of any amendment, supplement, or waiver to the Related Documents; and
- (ix) All reports, notices and correspondence to be delivered to holders of the Insured Bonds under the terms of the Related Documents.

In addition, to the extent that the District has entered into a continuing disclosure agreement, covenant or undertaking with respect to the Insured Bonds, all information furnished pursuant to such agreements shall also be provided to the Insurer, simultaneously with the furnishing of such information.

(p) The Insurer shall have the right to receive such additional information as it may reasonably request.

(q) The District will permit the Insurer to discuss the affairs, finances and accounts of the District or any information the Insurer may reasonably request regarding the security for the Insured Bonds with appropriate officers of the District and will use commercially reasonable efforts to enable the Insurer to have access to the facilities, books and records of the District on any business day upon reasonable prior notice.

(r) The Registrar shall notify the Insurer of any failure of the District to provide notices, certificates and other information under the transaction documents.

(s) In determining whether any amendment, consent, waiver or other action to be taken, or any failure to take action, under the Bond Resolution would adversely affect the security for the Insured Bonds or the rights of the holders of the Insured Bonds, the Registrar shall consider the effect of any such amendment, consent, waiver, action or inaction as if there were no Policy.

(t) No contract shall be entered into or any action taken by which the rights of the Insurer or security for or sources of payment of the Insured Bonds may be impaired or prejudiced in any material respect except upon obtaining the prior written consent of the Insurer.

Section 17. (a) If any one or more of the provisions of this Resolution should be determined by a court of competent jurisdiction to be contrary to law, then such provisions shall be deemed severable from the remaining provisions of this Resolution and the invalidity thereof shall in no way affect the validity of the other provisions of this Resolution or of the Bonds and the registered owners of the Bonds shall retain all the rights and benefits accorded to them under this Resolution and under any applicable provisions of law.

(b) If any provision of this Resolution shall be held or deemed to be or shall, in fact, be inoperative or unenforceable or invalid in any particular case in any jurisdiction or jurisdictions, or in all cases because it conflicts with any constitution or statute or rule of public policy, or for any other reason, such circumstances shall not have the effect of rendering the provision in question inoperative or unenforceable or invalid in any other case or circumstance, or of rendering any other provision or provisions herein contained inoperative or unenforceable or invalid to any extent whatever.

Section 18. All documents, agreements, certificates, and instruments related to the Bonds shall be valid, binding, and enforceable against the District when executed and delivered by means of (i) an original manual signature; (ii) a faxed, scanned, or photocopied manual signature, or (iii) any other electronic signature permitted by electronic signatures laws, including any relevant provisions of the Uniform Commercial Code, in each case to the extent applicable. Each faxed, scanned, or photocopied manual signature, or other electronic signature, shall for all purposes have the same validity, legal effect, and admissibility in evidence as an original manual signature. Each document, agreement, certificate, and instrument related to the Bonds may be executed in any number of counterparts, each of which shall be deemed to be an original, but such counterparts shall, together, constitute one and the same document, agreement, certificate, or instrument, as applicable.

Section 19. This Resolution shall take effect and be in force from and after its passage as provided by law.

PASSED AND ADOPTED: April 14, 2025.

**BUFFALO COUNTY SCHOOL DISTRICT 0069
(RAVENNA PUBLIC SCHOOLS), IN THE
STATE OF NEBRASKA**

ATTEST:

By: _____
President

By: _____
Secretary

Classroom Observation

First Name Last Name

0 years experience Ravenna Elem.

Observation Date:

02/26/2025

Standard 1: Uses Content Knowledge and Perspectives Aligned with Appropriate Instruction

Indicator 1.2 - The teacher cognitively engages students in the content.

- No opportunity to observe
- 0 - The teacher does not cognitively engage students in the content.
- 1 - The teacher seldom cognitively engages students in the content.
- 2
- 3 - The teacher occasionally cognitively engages students in the content less than half of the time, or with fewer than half of the students.
- 4
- 5 - The teacher often cognitively engages students in the content more than half of the time, or with more than half of the students.
- 6
- 7 - The teacher almost always cognitively engages students in the content and engages almost all the students.

0: • Does not use cognitive engagement strategies* to promote thinking about the content

- Students are not cognitively engaged in the content
- ECE - Does not provide opportunities to learn new skills or content; Does not encourage extension of discovery/play

- 1:**
- Ineffectively uses one or more potentially weak cognitive engagement strategies* to promote thinking about the content
 - Only cognitively engages one student at a time
 - ECE - Seldom reviews content; Seldom encourages extension of discovery/play; Few learners are cognitively immersed in learning activities/centers

- 3:**
- Uses appropriate cognitive engagement strategies* but not effectively
 - Misses opportunities for thinking about the content
 - Some students are cognitively engaged
 - Many students are minimally cognitively engaged
 - ECE - Occasionally reviews content; Occasionally encourages extension of discovery/play; Some learners interacting with content cognitively some of the time; Some learners are cognitively immersed in learning activities/centers

- 5:**
- Uses appropriate cognitive engagement strategies* effectively most of the time
 - Uses specific processing structures with students with some success
 - Most students are cognitively engaged much of the time
 - Recognizes if some students are not cognitively engaged, and tries alternate strategies to increase or maintain students' thinking about content
 - ECE - Often reviews and may spiral content; Often encourages extension of discovery/play; Many learners interact with content cognitively much of the time; Many learners are cognitively immersed in learning activities/centers

- 7:**
- Effectively uses cognitive engagement strategies* to promote thinking about the content almost all the time
 - Almost all students are cognitively engaged almost all the time
 - Uses specific processing structures with students with high success
 - Rapidly recognizes if some students are not cognitively engaged, and uses alternate strategies successfully to increase their thinking about content
 - Supports students in monitoring their own levels of cognitive engagement and in employing personal strategies to increase their engagement
 - ECE - Reviews frequently and spirals content; Consistently encourages extension of discovery/play; Almost all learners are cognitively immersed in learning activities/centers

* Cognitive engagement strategies may include advanced organizers, K-W-L charts, share-out, shoulder-partner, connecting instruction/activities with students' lives, showing relevance, using authentic examples, presenting a puzzling problem, and inviting responses from all students.

Remote Learning (RL) Environments

- The teacher provides asynchronous lectures that can include videos/multimedia to convey needed content knowledge.
- During synchronous work, nearly all students are actively engaged in discussing the content or actively working to complete a product that requires them to think about the learning.

Note: There are three distinct types of engagement in the classroom - cognitive, affective, and behavioral. This indicator addresses cognitive engagement only. The other forms of engagement are addressed in Indicators 5.1 and 5.2.

Comments

Standard 4: Teaches for Critical Thinking

Indicator 4.1 - The teacher uses instructional strategies that lead students to problem-solving and critical thinking.

No opportunity to observe

0 - The teacher does not use instructional strategies to promote student problem-solving or critical thinking skills.

1 - The teacher seldom uses instructional strategies that require students to problem-solve and think critically.

2

3 - The teacher occasionally uses instructional strategies that require students to problem-solve and think critically less than half of the time, or with fewer than half of the students.

4

5 - The teacher often uses instructional strategies that require students to problem-solve and think critically more than half of the time, or with more than half of the students.

6

7 - The teacher almost always uses instructional strategies that engage almost all students in learning activities to promote problem-solving and critical thinking continuously through almost all the lesson.

0:

- Students are not involved in problem-solving or critical thinking

1:

- Seldom uses questions that demand more than basic recall or mere opinion
- Almost always responds to own questions without wait time for student response
- Uses routine applications of known procedures, or highly guided or constrained tasks

- 3:**
- Occasionally uses instructional strategies that require some students to reason, problem-solve, and think critically (e.g., to assess or develop an informed argument, weigh credibility of evidence, justify or evaluate thinking, use cause-and-effect charts)
 - Uses some higher-order questions with skill (e.g., "how do you know?" or "why do others come to a different conclusion?") , but is not consistent
 - May provide opportunities for higher-order thinking (e.g., compare, analyze, infer, evaluate, explain, justify) without appropriate follow-through
 - Mostly uses routine applications of known procedures
 - May provide too much or too little scaffolding for problem solving
- 5:**
- Often uses instructional strategies that require most students to reason, problem-solve, and think critically
 - Models critical thinking and steps necessary to problem-solve for students, but misses some opportunities
 - May allow students to problem-solve independently instead of providing step-by-step instructions
 - Implements meaningful learning experiences that require most students to apply disciplinary knowledge to real-world problems
- 7:**
- If time allows, progresses fluently through multiple instructional strategies that require almost all students to think critically and problem-solve
 - Consistently requires students to explain or justify their thinking, problem-solve, formulate questions, predict, be creative, or make informed decisions
 - Almost all students consistently engage in individual or collaborative critical thinking and problem-solving, analysis, synthesis, interpretation, and creation of original products
 - Strongly models critical thinking

NOTE: In ECE, critical thinking may involve allowing learners to use materials in unique ways, looking at problems in different ways, generating their own ideas, or actively discovering, investigating, exploring, constructing, and creating. Also, critical thinking may involve letting learners take risks, experimenting, making mistakes, and letting learners lead and then following their lead.

RL Environments

- The teacher consistently requires students to explain/justify their thinking, practice problem-solving skills, formulate questions, predict outcomes, be creative, and/or make informed decisions.
- The teacher provides students with guidance and resources on how to show evidence of critical thinking or decision making.
- The teacher evaluates learning activities to ensure that students are engaged in critical thinking and/or problem-solving skills.

Comments

Standard 5: Creates a Positive Classroom Learning Environment

Indicator 5.1 - The teacher uses motivation strategies that affectively engage students.

No opportunity to observe

0 - The teacher does not use motivation strategies that affectively engage students.

1 - The teacher seldom uses motivation strategies that affectively engage students.

2

3 - The teacher occasionally uses motivation strategies that affectively engage students less than half of the time, or with fewer than half of the students.

4

5 - The teacher often uses motivation strategies that affectively engage students more than half of the time, or with more than half of the students.

6

7 - The teacher almost always uses motivation strategies that affectively engage almost all of the students.

- 0:**
- No evidence of motivation strategies* in use
 - ECE - Centers do not engage learners

- 1:**
- Uses a few motivation strategies* with limited success
 - Uses motivation strategies* in ways that undermine long-term motivation (e.g., sarcasm, threats)
 - Uses gimmicks that distract rather than engage students
 - Students may express boredom or frustration
 - ECE - Centers seldom engage learners or engage few learners; Learners seldom have opportunities to make choices and work independently

- 3:**
- Uses motivation strategies* with some success
 - Some students appear moderately motivated some of the time
 - Some students express positive emotions (e.g., interest, excitement, amusement, pride) for the learning activity some of the time
 - Lesson occasionally drags

- ECE - Centers engage some learners some of the time; Learners occasionally have opportunities to make choices and work independently

- 5:**
- Uses multiple motivation strategies* with much success
 - Most students appear motivated most of the time
 - Most students express positive emotions (e.g., interest, excitement, amusement, pride) for the learning activity most of the time
 - Some students may be unmotivated, but many are motivated
 - ECE - Centers engage most learners much of the time; Learners often have opportunities to make choices and work independently

- 7:**
- Uses multiple motivation strategies* with great success
 - Adjusts and refines use of motivation strategies* based on effectiveness
 - Almost all students appear highly motivated almost all of the time
 - Almost all students express positive emotions (e.g., interest, excitement, amusement, pride) for the learning activity almost all of the time
 - Students may be engaged in self-directed learning
 - ECE - Centers are fully engaging so that learners want to play; Lessons are developmentally appropriate, quick, and relevant; Teacher is enthusiastic

* This indicator emphasizes intrinsic motivation more than external motivation. Research-based motivation strategies may include using interesting materials, providing attractive choice (autonomy), praise (avoiding criticism), pointing out progress, communicating enthusiasm for the content, setting and achieving goals, promoting self-efficacy, and communicating that success is due to effort (not ability). In ECE, setting up centers is foundational and central to the lesson plan. Centers should motivate and affectively engage learners.

RL Environments – For this indicator, it is important to note that whole-class lectures may not keep students motivationally engaged.

- The teacher motivates students by selecting interesting topics, choosing topics that are applicable, allowing for student choice, encouraging students to set goals, and working with small groups and individuals.
- The teacher promotes student confidence by providing detailed feedback to each student.

Note: This indicator refers to positive emotions toward the content or lesson activities. Indicator 5.3b is about positive emotions toward the teacher.

Note: There are three distinct types of engagement in the classroom - cognitive, affective, and behavioral. This indicator addresses affective engagement only. The other forms of engagement are addressed in Indicators 1.2 and 5.2.

Comments

Indicator 5.2 - The teacher manages time, space, transitions, and activities.

No opportunity to observe

0 - The teacher does not manage time, space, transitions, and activities well.

1 - The teacher seldom manages time, space, transitions, and activities well. Time is not used efficiently for most students.

2

3 - The teacher occasionally manages time, space, transitions, and activities well less than half of the time, or with fewer than half of the students.

4

5 - The teacher often manages time, space, transitions, and activities well more than half of the time, or with more than half of the students.

6

7 - The teacher almost always organizes, allocates, and manages time, space, transitions, and activities well. Manages class so fluidly that management is invisible with almost all the students.

- 0:**
- No procedures for transitioning or managing time efficiently
 - Most students are on task less than 10% of the time
 - ECE - Learners are not involved in learning activities; No apparent procedures or expectations
- 1:**
- A few students are on task
 - Class time is centered on learning less than 20% of the time
 - Does not redirect students who are off-task, or has to stop frequently to redirect because students are unsure of directions
 - Back frequently turned to students; unaware of student behavior
 - Students have to wait for teacher because of poor management or planning
 - Seldom uses strategies* for managing time, space, and transitions
 - Directions unclear
 - Transitions are too long or not relevant
 - Teacher talks about transition, but then does not make transition
 - ECE - Many learners wandering the room; Few learners are involved in classroom routines
- 3:**
- Some students are on task
 - Class time is centered on learning about 35-50% of the time
 - Teacher manages time rather than students (i.e., is inflexible in scheduling)
 - Sometimes uses strategies* for managing time, space, and transitions
 - Does not fully minimize distractions or interruptions

- Teacher may change directions too often
- ECE - Some learners wandering the room; Some learners are involved in classroom routines

- 5:
- Most students are on task most of the time and appear to know classroom routines
 - Class time is centered on learning about 65-80% of the time
 - Students know what to do when the bell rings
 - Mostly uses strategies* for managing time, space, and transitions
 - Only minor redirects are needed
 - Transitions between instruction, demonstration, guided practice, and independent practice are fairly smooth
 - ECE - Most learners are involved in classroom routines; Learning occurs during most transitions (e.g., not standing in line doing nothing)

- 7:
- Almost all students are on task.
 - Class time is centered on learning more than 90% of the time
 - Strong evidence that students already know classroom routines and transitions
 - Students appear to be self-directed
 - Always uses strategies* for managing time, space, and transitions
 - Students collaborate on the effective management of time, space, transitions, and activities
 - ECE - Adequate amount of quality materials in room (e.g., realistic, developmentally appropriate); Visual schedules are present and actively used; Transitions are well organized (e.g., with lights, cues, movement, music); Learning occurs during transitions; Learners are busy and active; Learners are involved in routines. Room is warm, inviting, and organized.

* Strategies may include having effective seating structures, having sufficient materials in the room, clearly communicating procedures for entering or finishing work, and clearly communicating behavioral expectations.

Note: There are three distinct types of engagement in the classroom - cognitive, affective, and behavioral. This indicator addresses behavioral engagement only. The other forms of engagement are addressed in Indicators 1.2 and 5.1.

Comments

Standard 7: Uses Student Assessment Data to Analyze and Modify Instruction

Indicator 7.4 - The teacher monitors the effect of instruction on the whole class and individual learning.

NOTE: Must take corrective action, if needed and appropriate, to score above a 2.

No opportunity to observe

0 - The teacher does not check the effect of instruction on the whole class or individual learning.

1 - The teacher seldom conducts formative, on-the-spot assessment of learning for the whole class or individual students and does not take needed corrective action.

2

3 - The teacher occasionally conducts formative, on-the-spot assessment of learning for the whole class and individual students and takes corrective action as needed, less than half of the time, or for fewer than half of the students.

4

5 - The teacher often conducts formative, on-the-spot assessment of learning for the whole class and individual students and takes corrective action as needed more than half of the time, or for more than half of the students.

6

7 - The teacher almost always conducts formative, on-the-spot assessment of learning and takes corrective action as needed for both the whole class and almost all individual students.

- 0:
- Does not assess whether students have achieved the lesson objective
 - Does not engage in on-the-spot assessment

- 1:
- Seldom monitors learning progress
 - May superficially use question and answer as assessment
 - Minimal follow-up or checking for understanding
 - Monitors learning somewhat, but does not take corrective action

- 3:
- Occasionally quickly assesses understanding of some students before moving on to the next learning activity
 - Occasionally uses techniques to monitor learning progress (e.g., observing classroom interactions or student work, questioning, thumbs up, fist-to-five, white boarding, exit slips)
 - May monitor progress of the class as a whole
 - If needed and appropriate, some corrective action is taken

- 5:
- Often monitors learning progress of most students
 - Monitors the whole class and many individuals
 - May use multiple checks for understanding
 - Often adjusts instruction using students' responses to questions and discussions, correcting misconceptions, or monitoring other feedback
 - Takes corrective action as needed and appropriate for the class as a whole and most individual students

- 7:
- Systematically monitors learning progress
 - Continuously monitors progress in attaining instructional objectives for the whole class and for each student
 - On-the-spot assessment is seamless throughout instruction
 - Strong, appropriate corrective action is taken to ensure learning of almost all students

In ECE, the same look-fors are applicable across grade levels, but the method of assessment may place greater reliance on informal teacher observation, portfolios, data tracking sheets, and anecdotal notes. In addition, evaluators may want to focus on percentage of time rather than percentage of students. Teachers often cannot assess all three-year-olds at once, although some activities may provide quick checks for understanding among all learners. Assessment should be developmentally appropriate, may involve scaffolding, and be tailored to individual learner's zone of proximal development.

RL Environments

- The teacher consistently gathers data from each student to determine the current level of understanding and then adjusts instruction to help each student progress towards mastery.
- The teacher communicates with every student to ensure understanding of the learning target, the current level of achievement, and what is left to learn or complete in order to reach mastery.
- The teacher employs strategies to monitor individual mastery in asynchronous learning.
- The teacher provides detailed feedback to each student to promote growth.

Comments

Standard 8: Develops Professional Practices

Indicator 8.3 - The teacher observes, promotes, and supports professional rights, responsibilities, and ethical practices.

No opportunity to observe

Comments

General Comments

Classroom Observation

First Name Last Name

0 years experience Ravenna Elem.

Observation Date:

02/26/2025

Standard 1: Uses Content Knowledge and Perspectives Aligned with Appropriate Instruction

Indicator 1.2 - The teacher cognitively engages students in the content.

- No opportunity to observe
- 0 - The teacher does not cognitively engage students in the content.
- 1 - The teacher seldom cognitively engages students in the content.
- 2
- 3 - The teacher occasionally cognitively engages students in the content less than half of the time, or with fewer than half of the students.
- 4
- 5 - The teacher often cognitively engages students in the content more than half of the time, or with more than half of the students.
- 6
- 7 - The teacher almost always cognitively engages students in the content and engages almost all the students.

Comments

Standard 4: Teaches for Critical Thinking

Indicator 4.1 - The teacher uses instructional strategies that lead students to problem-solving and critical thinking.

- No opportunity to observe
- 0 - The teacher does not use instructional strategies to promote student problem-solving or critical thinking skills.
- 1 - The teacher seldom uses instructional strategies that require students to problem-solve and think critically.
- 2
- 3 - The teacher occasionally uses instructional strategies that require students to problem-solve and think critically less than half of the time, or with fewer than half of the students.
- 4
- 5 - The teacher often uses instructional strategies that require students to problem-solve and think critically more than half of the time, or with more than half of the students.
- 6
- 7 - The teacher almost always uses instructional strategies that engage almost all students in learning activities to promote problem-solving and critical thinking continuously through almost all the lesson.

Comments

Standard 5: Creates a Positive Classroom Learning Environment

Indicator 5.1 - The teacher uses motivation strategies that affectively engage students.

- No opportunity to observe
- 0 - The teacher does not use motivation strategies that affectively engage students.
- 1 - The teacher seldom uses motivation strategies that affectively engage students.
- 2
- 3 - The teacher occasionally uses motivation strategies that affectively engage students less than half of the time, or with fewer than half of the students.
- 4
- 5 - The teacher often uses motivation strategies that affectively engage students more than half of the time, or with more than half of the students.
- 6
- 7 - The teacher almost always uses motivation strategies that affectively engage almost all of the students.

Comments

Indicator 5.2 - The teacher manages time, space, transitions, and activities.

- No opportunity to observe
- 0 - The teacher does not manage time, space, transitions, and activities well.
- 1 - The teacher seldom manages time, space, transitions, and activities well. Time is not used efficiently for most students.

2

3 - The teacher occasionally manages time, space, transitions, and activities well less than half of the time, or with fewer than half of the students.

4

5 - The teacher often manages time, space, transitions, and activities well more than half of the time, or with more than half of the students.

6

7 - The teacher almost always organizes, allocates, and manages time, space, transitions, and activities well. Manages class so fluidly that management is invisible with almost all the students.

Comments

Standard 7: Uses Student Assessment Data to Analyze and Modify Instruction

Indicator 7.4 - The teacher monitors the effect of instruction on the whole class and individual learning.

NOTE: Must take corrective action, if needed and appropriate, to score above a 2.

No opportunity to observe

0 - The teacher does not check the effect of instruction on the whole class or individual learning.

1 - The teacher seldom conducts formative, on-the-spot assessment of learning for the whole class or individual students and does not take needed corrective action.

2

3 - The teacher occasionally conducts formative, on-the-spot assessment of learning for the whole class and individual students and takes corrective action as needed, less than half of the time, or for fewer than half of the students.

4

5 - The teacher often conducts formative, on-the-spot assessment of learning for the whole class and individual students and takes corrective action as needed more than half of the time, or for more than half of the students.

6

7 - The teacher almost always conducts formative, on-the-spot assessment of learning and takes corrective action as needed for both the whole class and almost all individual students.

Comments

Standard 8: Develops Professional Practices

Indicator 8.3 - The teacher observes, promotes, and supports professional rights, responsibilities, and ethical practices.

No opportunity to observe

Comments

General Comments



15 E Midland Ave St 502
Paramus, NJ, 07652-2938

Claudine Kennicutt
Ravenna School District 69
PO Box 8400
Ravenna, NE 68869-8400

Quote Number: Q-133510
Quote Creation Date: 1/21/2025
Quote Expiration Date: 9/30/2025

Ravenna School District 69 myView ELA K-6
Price Quote Summary

Solution	Base Amount	Free Amount	Total
Elementary Separate	\$5,400.00	\$0.00	\$5,400.00
myPerspectives English Language Arts	\$6,794.00	\$718.00	\$6,794.00
myPerspectives Professional Development	\$1,550.00	\$750.00	\$1,550.00
myView Literacy	\$55,944.00	\$40,175.00	\$55,944.00
myView Literacy Professional Development	\$2,300.00	\$0.00	\$2,300.00
Secondary Separate	\$900.00	\$0.00	\$900.00
SuccessMaker	\$2,300.00	\$0.00	\$2,300.00
Solution Subtotal:	\$75,188.00	\$41,643.00	\$75,188.00

Shipping and Handling:	\$5,520.79
Total:	\$80,708.79



15 E Midland Ave St 502
Paramus, NJ, 07652-2938

Price Quote Detail

Elementary Separate

Elementary Separate - Grade K

ISBN	Description	Price	Free Qty	Charged Qty	Free Amount	Total Charged
9781418393625	LITERACY SCREENER AND DIAGNOSTIC ASSESSMENT DIGITAL 6-YEAR LICENSE GRADEK	\$30.00	0	30	\$0.00	\$900.00
Elementary Separate - Grade K - Subtotal:					\$0.00	\$900.00

Elementary Separate - Grade 1

ISBN	Description	Price	Free Qty	Charged Qty	Free Amount	Total Charged
9781418393632	LITERACY SCREENER AND DIAGNOSTIC ASSESSMENT DIGITAL 6-YEAR LICENSE GRADE1	\$30.00	0	30	\$0.00	\$900.00
Elementary Separate - Grade 1 - Subtotal:					\$0.00	\$900.00

Elementary Separate - Grade 2

ISBN	Description	Price	Free Qty	Charged Qty	Free Amount	Total Charged
9781418393649	LITERACY SCREENER AND DIAGNOSTIC ASSESSMENT DIGITAL 6-YEAR LICENSE GRADE2	\$30.00	0	30	\$0.00	\$900.00
Elementary Separate - Grade 2 - Subtotal:					\$0.00	\$900.00

Elementary Separate - Grade 3

ISBN	Description	Price	Free Qty	Charged Qty	Free Amount	Total Charged
9781418393656	LITERACY SCREENER AND DIAGNOSTIC ASSESSMENT DIGITAL 6-YEAR LICENSE GRADE3	\$30.00	0	30	\$0.00	\$900.00
Elementary Separate - Grade 3 - Subtotal:					\$0.00	\$900.00

Elementary Separate - Grade 4

ISBN	Description	Price	Free Qty	Charged Qty	Free Amount	Total Charged
9781418393663	LITERACY SCREENER AND DIAGNOSTIC ASSESSMENT DIGITAL 6-YEAR LICENSE GRADE4	\$30.00	0	30	\$0.00	\$900.00
Elementary Separate - Grade 4 - Subtotal:					\$0.00	\$900.00

Elementary Separate - Grade 5

ISBN	Description	Price	Free Qty	Charged Qty	Free Amount	Total Charged
9781418393670	LITERACY SCREENER AND DIAGNOSTIC ASSESSMENT DIGITAL 6-YEAR LICENSE GRADES	\$30.00	0	30	\$0.00	\$900.00
Elementary Separate - Grade 5 - Subtotal:					\$0.00	\$900.00

myPerspectives English Language Arts

myPerspective English Language Arts ©2022 - Novels

ISBN	Description	Price	Free Qty	Charged Qty	Free Amount	Total Charged
0000123691	MYPERSPECTIVES NOVEL ENTITLEMENT	\$12.00	30	0	\$360.00	\$0.00
myPerspective English Language Arts ©2022 - Novels - Subtotal:					\$360.00	\$0.00

Grade 6 - Consumable + SuccessMaker

ISBN	Description	Price	Free Qty	Charged Qty	Free Amount	Total Charged
9798213016802	MYPERSPECTIVES 2025 CONSUMABLE STUDENT EDITION + 6-YEAR SUCCESSMAKER + 6-YEAR LICENSE GRADE 6	\$220.50	0	30	\$0.00	\$6,615.00
Grade 6 - Consumable + SuccessMaker - Subtotal:					\$0.00	\$6,615.00

Grade 6 - SE/TE

ISBN	Description	Price	Free Qty	Charged Qty	Free Amount	Total Charged
9781428516533	MYPERSPECTIVES 2025 TEACHER EDITION GRADE 6	\$179.00	2	1	\$358.00	\$179.00
Grade 6 - SE/TE - Subtotal:					\$358.00	\$179.00

myPerspectives Professional Development

myPerspectives Professional Development - myPerspectives ©2025 Professional Learning Offerings

ISBN	Description	Price	Free Qty	Charged Qty	Free Amount	Total Charged
0000126537	VIRTUAL MYPERSPECTIVES @2025 IMPLEMENTATION ESSENTIALS (3 HRS) PREPAID	\$1,550.00	0	1	\$0.00	\$1,550.00
0000126550	VIRTUAL MYPERSPECTIVES @2025 PROGRAM ACTIVATION PREPAID	\$750.00	1	0	\$750.00	\$0.00
myPerspectives Professional Development - myPerspectives ©2025 Professional Learning Offerings - Subtotal:					\$750.00	\$1,550.00



15 E Midland Ave St 502
Paramus, NJ, 07652-2938

myView Literacy

myView Literacy © 2025 - Grade K

ISBN	Description	Price	Free Qty	Charged Qty	Free Amount	Total Charged
9798213025071	MVWLIT25 SKILLS PRACTICE BOOK GRADE K	\$21.00	0	2	\$0.00	\$42.00
9798213038354	MYVIEW LITERACY 2025 PREMIUM STANDARD 6-YEAR CONSUMABLE WITH 6-YEAR DIGITAL + 6-YEAR SUCCESSMAKER GRADE K	\$242.00	0	30	\$0.00	\$7,260.00
9780328993901	MYVIEW LITERACY 2020 MYFOCUS INTERVENTION TEACHING GUIDE LEVEL A	\$356.00	2	0	\$712.00	\$0.00
9798213020458	MYVIEW LITERACY 2025 TEACHER EDITION PACKAGE GRADE K	\$2,022.00	2	1	\$4,044.00	\$2,022.00
9798213020588	MYVIEW LITERACY 2025 BIG BOOK PACKAGE GRADE K	\$1,298.00	2	0	\$2,596.00	\$0.00
9798213020595	MYVIEW LITERACY 2025 FOUNDATIONAL SKILLS KIT GRADE K	\$1,462.00	2	0	\$2,924.00	\$0.00
myView Literacy © 2025 - Grade K - Subtotal:					\$10,276.00	\$9,324.00

myView Literacy © 2025 - Grade 1

ISBN	Description	Price	Free Qty	Charged Qty	Free Amount	Total Charged
9798213025088	MVWLIT25 SKILLS PRACTICE BOOK GRADE 1	\$21.00	0	2	\$0.00	\$42.00
9798213038361	MYVIEW LITERACY 2025 PREMIUM STANDARD 6-YEAR CONSUMABLE WITH 6-YEAR DIGITAL + 6-YEAR SUCCESSMAKER GRADE 1	\$242.00	0	30	\$0.00	\$7,260.00
9798213020601	MYVIEW LITERACY 2025 FOUNDATIONAL SKILLS KIT GRADE 1	\$1,332.50	2	0	\$2,665.00	\$0.00
9798213020465	MYVIEW LITERACY 2025 TEACHER EDITION PACKAGE GRADE 1	\$2,022.00	2	1	\$4,044.00	\$2,022.00
9780328991402	MYVIEW LITERACY 2020 SONGS & POEMS BIG BOOK GRADE 1	\$103.50	2	0	\$207.00	\$0.00
9780134934358	MYVIEW LITERACY 2020 MYFOCUS INTERVENTION PACKAGE LEVEL B	\$500.00	2	0	\$1,000.00	\$0.00
myView Literacy © 2025 - Grade 1 - Subtotal:					\$7,916.00	\$9,324.00

myView Literacy © 2025 - Grade 2

ISBN	Description	Price	Free Qty	Charged Qty	Free Amount	Total Charged
9798213038378	MYVIEW LITERACY 2025 PREMIUM STANDARD 6-YEAR CONSUMABLE WITH 6-YEAR DIGITAL + 6-YEAR SUCCESSMAKER GRADE 2	\$242.00	0	30	\$0.00	\$7,260.00

ISBN	Description	Price	Free Qty	Charged Qty	Free Amount	Total Charged
9798213025095	MVWLIT25 SKILLS PRACTICE BOOK GRADE 2	\$21.00	0	2	\$0.00	\$42.00
9798213020618	MYVIEW LITERACY 2025 FOUNDATIONAL SKILLS KIT GRADE 2	\$903.50	2	0	\$1,807.00	\$0.00
9780134934365	MYVIEW LITERACY 2020 MYFOCUS INTERVENTION PACKAGE LEVEL C	\$500.00	2	0	\$1,000.00	\$0.00
9798213020472	MYVIEW LITERACY 2025 TEACHER EDITION PACKAGE GRADE 2	\$2,022.00	2	1	\$4,044.00	\$2,022.00
myView Literacy © 2025 - Grade 2 - Subtotal:					\$6,851.00	\$9,324.00

myView Literacy © 2025 - Grade 3

ISBN	Description	Price	Free Qty	Charged Qty	Free Amount	Total Charged
9798213038385	MYVIEW LITERACY 2025 PREMIUM STANDARD 6-YEAR CONSUMABLE WITH 6-YEAR DIGITAL + 6-YEAR SUCCESSMAKER GRADE 3	\$242.00	0	30	\$0.00	\$7,260.00
9798213025101	MVWLIT25 SKILLS PRACTICE BOOK GRADE 3	\$21.00	0	2	\$0.00	\$42.00
9798213020489	MYVIEW LITERACY 2025 TEACHER EDITION PACKAGE GRADE 3	\$2,022.00	2	1	\$4,044.00	\$2,022.00
9780134934372	MYVIEW LITERACY 2020 MYFOCUS INTERVENTION PACKAGE LEVEL D	\$500.00	2	0	\$1,000.00	\$0.00
myView Literacy © 2025 - Grade 3 - Subtotal:					\$5,044.00	\$9,324.00

myView Literacy © 2025 - Grade 4

ISBN	Description	Price	Free Qty	Charged Qty	Free Amount	Total Charged
9798213025118	MVWLIT25 SKILLS PRACTICE BOOK GRADE 4	\$21.00	0	2	\$0.00	\$42.00
9798213038392	MYVIEW LITERACY 2025 PREMIUM STANDARD 6-YEAR CONSUMABLE WITH 6-YEAR DIGITAL + 6-YEAR SUCCESSMAKER GRADE 4	\$242.00	0	30	\$0.00	\$7,260.00
9798213020496	MYVIEW LITERACY 2025 TEACHER EDITION PACKAGE GRADE 4	\$2,022.00	2	1	\$4,044.00	\$2,022.00
9780134934396	MYVIEW LITERACY 2020 MYFOCUS INTERVENTION PACKAGE LEVEL E	\$500.00	2	0	\$1,000.00	\$0.00
myView Literacy © 2025 - Grade 4 - Subtotal:					\$5,044.00	\$9,324.00

myView Literacy © 2025 - Grade 5

ISBN	Description	Price	Free Qty	Charged Qty	Free Amount	Total Charged
9798213038408	MYVIEW LITERACY 2025 PREMIUM STANDARD 6-YEAR CONSUMABLE WITH 6-YEAR DIGITAL + 6-YEAR SUCCESSMAKER GRADE 5	\$242.00	0	30	\$0.00	\$7,260.00
9798213025125	MVWLIT25 SKILLS PRACTICE BOOK GRADE 5	\$21.00	0	2	\$0.00	\$42.00
9798213020502	MYVIEW LITERACY 2025 TEACHER EDITION PACKAGE GRADE 5	\$2,022.00	2	1	\$4,044.00	\$2,022.00
9780134934402	MYVIEW LITERACY 2020 MYFOCUS INTERVENTION PACKAGE LEVEL F	\$500.00	2	0	\$1,000.00	\$0.00
myView Literacy © 2025 - Grade 5 - Subtotal:					\$5,044.00	\$9,324.00

myView Literacy Professional Development

myView Literacy Professional Development - myView Literacy ©2025 Professional Learning Offerings

ISBN	Description	Price	Free Qty	Charged Qty	Free Amount	Total Charged
0000126505	VIRTUAL MYVIEW LITERACY 2025 IMPLEMENTATION ESSENTIALS (3 HRS) PREPAID	\$1,550.00	0	1	\$0.00	\$1,550.00
0000126532	VIRTUAL MYVIEW LITERACY 2025 PROGRAM ACTIVATION PREPAID	\$750.00	0	1	\$0.00	\$750.00
myView Literacy Professional Development - myView Literacy ©2025 Professional Learning Offerings - Subtotal:					\$0.00	\$2,300.00

Secondary Separate

Secondary Separate - Grade 6

ISBN	Description	Price	Free Qty	Charged Qty	Free Amount	Total Charged
9781418393687	LITERACY SCREENER AND DIAGNOSTIC ASSESSMENT DIGITAL 6-YEAR LICENSE GRADE6	\$30.00	0	30	\$0.00	\$900.00
Secondary Separate - Grade 6 - Subtotal:					\$0.00	\$900.00

SuccessMaker

SuccessMaker - SuccessMaker Professional Learning

ISBN	Description	Price	Free Qty	Charged Qty	Free Amount	Total Charged
0000125108	VIRTUAL SUCCESSMAKER IMPLEMENTATION ESSENTIAL 3-HOURS	\$1,550.00	0	1	\$0.00	\$1,550.00
0000125117	VIRTUAL SUCCESSMAKER INITIAL TRAINING 2-HOUR	\$750.00	0	1	\$0.00	\$750.00
SuccessMaker - SuccessMaker Professional Learning - Subtotal:					\$0.00	\$2,300.00



15 E Midland Ave St 502
Paramus, NJ, 07652-2938

Solution Subtotal:	\$41,643.00	\$75,188.00
Shipping and Handling:		\$5,520.79
Total:		\$80,708.79

Optional Products

ISBN	DESCRIPTION	Price	Total Quantity	Base Amount	Total Charged
9798213402315	MVLIT25 LANGUAGE AWARENESS HANDBOOK GRADE 1	\$118.50	2	\$237.00	\$237.00
9798213020632	MYVIEW LITERACY 2025 BUILDING KNOWLEDGE LIBRARY COLLECTION GRADE 1	\$1,641.00	2	\$3,282.00	\$3,282.00
9798213446067	MYVIEW LITERACY 2025 SKILLS PRACTICE BOOK 6-YEAR SUBSCRIPTION GRADE 1	\$85.50	30	\$2,565.00	\$2,565.00
9798213402322	MVLIT25 LANGUAGE AWARENESS HANDBOOK GRADE 2	\$118.50	2	\$237.00	\$237.00
9798213020649	MYVIEW LITERACY 2025 BUILDING KNOWLEDGE LIBRARY COLLECTION GRADE 2	\$1,363.00	2	\$2,726.00	\$2,726.00
9798213446074	MYVIEW LITERACY 2025 SKILLS PRACTICE BOOK 6-YEAR SUBSCRIPTION GRADE 2	\$85.50	30	\$2,565.00	\$2,565.00
9798213402339	MVLIT25 LANGUAGE AWARENESS HANDBOOK GRADE 3	\$118.50	2	\$237.00	\$237.00
9798213020656	MYVIEW LITERACY 2025 BUILDING KNOWLEDGE LIBRARY COLLECTION GRADE 3	\$1,335.00	2	\$2,670.00	\$2,670.00
9798213446081	MYVIEW LITERACY 2025 SKILLS PRACTICE BOOK 6-YEAR SUBSCRIPTION GRADE 3	\$85.50	30	\$2,565.00	\$2,565.00
9798213402346	MVLIT25 LANGUAGE AWARENESS HANDBOOK GRADE 4	\$118.50	2	\$237.00	\$237.00
9798213020663	MYVIEW LITERACY 2025 BUILDING KNOWLEDGE LIBRARY COLLECTION GRADE 4	\$1,418.50	2	\$2,837.00	\$2,837.00
9798213446098	MYVIEW LITERACY 2025 SKILLS PRACTICE BOOK 6-YEAR SUBSCRIPTION GRADE 4	\$85.50	30	\$2,565.00	\$2,565.00
9798213402353	MVLIT25 LANGUAGE AWARENESS HANDBOOK GRADE 5	\$118.50	2	\$237.00	\$237.00
9798213020670	MYVIEW LITERACY 2025 BUILDING KNOWLEDGE LIBRARY COLLECTION GRADE 5	\$1,418.50	2	\$2,837.00	\$2,837.00
9798213446104	MYVIEW LITERACY 2025 SKILLS PRACTICE BOOK 6-YEAR SUBSCRIPTION GRADE 5	\$85.50	30	\$2,565.00	\$2,565.00
9798213402308	MVLIT25 LANGUAGE AWARENESS HANDBOOK GRADE K	\$118.50	2	\$237.00	\$237.00
9798213020625	MYVIEW LITERACY 2025 BUILDING KNOWLEDGE LIBRARY COLLECTION GRADE K	\$1,335.00	2	\$2,670.00	\$2,670.00
9798213446050	MYVIEW LITERACY 2025 SKILLS PRACTICE BOOK 6-YEAR SUBSCRIPTION GRADE K	\$85.50	30	\$2,565.00	\$2,565.00



15 E Midland Ave St 502
Paramus, NJ, 07652-2938

Savvas Learning Company LLC Terms and Conditions

To place your order please submit a copy of this price quote with your Purchase Order, include the Quote Number on your Purchase Order, and include any other required documentation. You may send the order documents using an electronic form or by mail. Please submit your PO and price quote via one of the following methods:

Online:

<https://support.savvas.com/support/s/customerserviceus>

Mail: PO Box 6820, Chandler, AZ 85246

Savvas does not accept Credit Card information via postal mail, facsimile, or email. Credit Card information will only be accepted via phone, eCommerce, or my Savvas Orders. For questions regarding your order please call Customer Service: 1-800-848-9500.

Price quote: This is a price quote for the customer's convenience only, and not an offer to contract. All quotes are subject to review and final acceptance by an authorized representative of Savvas at its offices. Savvas reserves the right to correct typographical, computational or other errors. Savvas' standard payment terms are net 30 days unless otherwise specified. All pricing is in US Dollars unless otherwise specified. Pricing calculations use multiple decimal places to determine the most accurate extended pricing but are represented in standard currency format.

Shipping & handling charges (where applicable) are shown on the quote. S&H rates quoted are for standard ground transportation and may not reflect account contracted rates. If expedited shipping is requested, actual charges may be higher. For orders picked up at the Savvas warehouse by the customer or a third party carrier contracted by the customer, a 2% handling charge will be applied to shippable items. The 2% charge will appear on the customer proposal and invoice as a S&H charge.

Taxes: All pricing in this quote is exclusive of any applicable sales, use or other similar taxes or duties. The customer is responsible for any such taxes or duties that may apply; if the customer is tax exempt, evidence of such tax exemption must be provided. Estimated tax may be provided solely for customer convenience. The amount indicated is only an estimate and is intended to be helpful for budgeting purposes. The actual amount of sales tax assessed at the time of invoicing may be more or less.

Platforms: Savvas, and any third party for which Savvas serves as the sales agent or distributor, reserve the right to change and/or update technology platforms, including possible edition updates to customers during the term of access. Customers will be notified of any change prior to the beginning of the new school year.

Damaged & Defective Products: If a print product, or the print component of a blended (print & digital) product, is received in damaged or defective condition, Savvas will issue a credit or replacement at no charge to the customer if the customer promptly (no later than 120 days) returns the damaged or defective product. Customers must report missing product immediately upon receipt.

Return Policy: Returns (other than damaged or defective products) are subject to the following conditions: (a) materials must be returned to Savvas at the customer's expense in new, unused condition, suitable for resale by Savvas (note that any barcoding, stickering, stamping or similar marking on any print materials renders them unsuitable for resale); (b) materials must be returned within six (6) months from the date of purchase; (c) the customer must obtain a Return Materials Authorization ("RMA") from Savvas prior to returning the materials, and must ship the materials back to Savvas within thirty days of receiving the RMA; (d) all materials sold in a set or package must be returned complete as originally sold; and (e) any materials provided by Savvas to the customer on a no-charge basis in consideration of the customer's purchase must be returned in proportion to the purchased materials that are being returned for a credit. A restocking fee of 3% may be applied to credits over \$1,000. Savvas' return policy does not apply to science lab kits or trade publication novels, which are sold on a non-returnable basis.

Consumable Worktexts: Subsequent year consumable worktexts will ship each year on the anniversary of the original order date for the duration of their license. Worktexts will ship to the location listed on the original order. Quantities for each grade level and title will remain consistent each year. Changes to quantities of titles previously ordered, shipping location changes, or any other changes to consumable worktext shipments must be made 4 weeks prior to shipment date. (the anniversary of the original order date unless changed). Changes can be made on the Subscription Worktext Site: <https://worktext-subscriptions.savvas.com>

Annual subscriptions for iLit and Successmaker Only: Savvas' iLit and Successmaker products (and no others) automatically renew on the anniversary date of the original purchase and will be invoiced accordingly unless otherwise specified.

Technical support services are included with purchase of Savvas digital products.

Online help:

<https://support.savvas.com/support/s/k12-curriculum-support-form>

phone: 1-800-848-9500

Professional Services: All paid services must be delivered within twelve (12) months of the order date of those services. Any unused services expire at the end of such twelve (12) month period, unless otherwise specified in contract terms. Any cancellation made with less than 72 hours' notice will result in a cancellation fee equal to the full price of the event. MySavvasTraining is included with purchase of products (<https://mysavvastraining.com>).

	2024-2025 est	0% increase in wage	0.5% increase in wage	1% increase in wage	1.5% increase in wage	2% increase in wage	2.5% increase in wage	3% increase in wage	3.25% increase in wage	3.5% increase in wage	3.75% increase in wage	4% increase in wage
Kitchen												
Gross Wage	\$ 153,465.00	\$ 153,465.00	\$ 154,232.33	\$ 154,999.65	\$ 155,766.98	\$ 156,534.30	\$ 157,301.63	\$ 158,068.95	\$ 158,452.61	\$ 158,836.28	\$ 159,219.94	\$ 159,603.60
Soc Sec/med	\$ 11,740.07	\$ 11,740.07	\$ 11,798.77	\$ 11,857.47	\$ 11,916.17	\$ 11,974.87	\$ 12,033.57	\$ 12,092.27	\$ 12,121.62	\$ 12,150.98	\$ 12,180.33	\$ 12,209.68
Retirement	\$ 15,158.97	\$ 15,158.97	\$ 15,234.76	\$ 15,310.56	\$ 15,386.35	\$ 15,462.15	\$ 15,537.94	\$ 15,613.73	\$ 15,651.63	\$ 15,689.53	\$ 15,727.43	\$ 15,765.32
Insurance	\$ 55,057.68	\$ 58,551.00	\$ 58,551.00	\$ 58,551.00	\$ 58,551.00	\$ 58,551.00	\$ 58,551.00	\$ 58,551.00	\$ 58,551.00	\$ 58,551.00	\$ 58,551.00	\$ 58,551.00
Total	\$ 235,421.72	\$ 238,915.04	\$ 239,816.86	\$ 240,718.68	\$ 241,620.50	\$ 242,522.32	\$ 243,424.14	\$ 244,325.96	\$ 244,776.87	\$ 245,227.78	\$ 245,678.69	\$ 246,129.60
Total Compensation %		101.48%	101.87%	102.25%	102.63%	103.02%	103.40%	103.78%	103.97%	104.17%	104.36%	104.55%
Custodial												
Gross Wage	\$ 228,826.00	\$ 228,826.00	\$ 229,970.13	\$ 231,114.26	\$ 232,258.39	\$ 233,402.52	\$ 234,546.65	\$ 235,690.78	\$ 236,262.85	\$ 236,834.91	\$ 237,406.98	\$ 237,979.04
Soc Sec/med	\$ 17,505.19	\$ 17,505.19	\$ 17,592.71	\$ 17,680.24	\$ 17,767.77	\$ 17,855.29	\$ 17,942.82	\$ 18,030.34	\$ 18,074.11	\$ 18,117.87	\$ 18,161.63	\$ 18,205.40
Retirement	\$ 22,602.97	\$ 22,602.97	\$ 22,715.99	\$ 22,829.00	\$ 22,942.02	\$ 23,055.03	\$ 23,168.05	\$ 23,281.06	\$ 23,337.57	\$ 23,394.08	\$ 23,450.59	\$ 23,507.09
Insurance	\$ 55,400.00	\$ 58,582.00	\$ 58,582.00	\$ 58,582.00	\$ 58,582.00	\$ 58,582.00	\$ 58,582.00	\$ 58,582.00	\$ 58,582.00	\$ 58,582.00	\$ 58,582.00	\$ 58,582.00
Total	\$ 324,334.16	\$ 327,516.16	\$ 328,860.83	\$ 330,205.51	\$ 331,550.18	\$ 332,894.85	\$ 334,239.52	\$ 335,584.19	\$ 336,256.52	\$ 336,928.86	\$ 337,601.19	\$ 338,273.53
Total Compensation %		100.98%	101.40%	101.81%	102.22%	102.64%	103.05%	103.47%	103.68%	103.88%	104.09%	104.30%
Bus Drivers												
Gross Wage	\$ 184,522.00	\$ 184,522.00	\$ 185,444.61	\$ 186,367.22	\$ 187,289.83	\$ 188,212.44	\$ 189,135.05	\$ 190,057.66	\$ 190,518.97	\$ 190,980.27	\$ 191,441.58	\$ 191,902.88
Soc Sec/med	\$ 14,115.93	\$ 14,115.93	\$ 14,186.51	\$ 14,257.09	\$ 14,327.67	\$ 14,398.25	\$ 14,468.83	\$ 14,539.41	\$ 14,574.70	\$ 14,609.99	\$ 14,645.28	\$ 14,680.57
Retirement	\$ 11,702.45	\$ 11,702.45	\$ 11,760.96	\$ 11,819.47	\$ 11,877.99	\$ 11,936.50	\$ 11,995.01	\$ 12,053.52	\$ 12,082.78	\$ 12,112.04	\$ 12,141.29	\$ 12,170.55
Insurance	\$ 8,415.60	\$ 8,766.00	\$ 8,766.00	\$ 8,766.00	\$ 8,766.00	\$ 8,766.00	\$ 8,766.00	\$ 8,766.00	\$ 8,766.00	\$ 8,766.00	\$ 8,766.00	\$ 8,766.00
Total	\$ 218,755.98	\$ 219,106.38	\$ 220,158.08	\$ 221,209.79	\$ 222,261.49	\$ 223,313.19	\$ 224,364.89	\$ 225,416.59	\$ 225,942.45	\$ 226,468.30	\$ 226,994.15	\$ 227,520.00
Total Compensation %		100.16%	100.64%	101.12%	101.60%	102.08%	102.56%	103.04%	103.29%	103.53%	103.77%	104.01%
Total for ALL	\$ 7,025.72	\$ 10,323.91	\$ 13,622.11	\$ 16,920.30	\$ 20,218.49	\$ 23,516.68	\$ 26,814.88	\$ 28,463.97	\$ 30,113.07	\$ 31,762.17	\$ 33,411.26	
Nurse												
Gross Wage	\$ 55,132.00	\$ 55,132.00	\$ 55,407.66	\$ 55,683.32	\$ 55,958.98	\$ 56,234.64	\$ 56,510.30	\$ 56,785.96	\$ 56,923.79	\$ 57,061.62	\$ 57,199.45	\$ 57,337.28
Soc Sec/med	\$ 4,217.60	\$ 4,217.60	\$ 4,238.69	\$ 4,259.77	\$ 4,280.86	\$ 4,301.95	\$ 4,323.04	\$ 4,344.13	\$ 4,354.67	\$ 4,365.21	\$ 4,375.76	\$ 4,386.30
Retirement	\$ 5,445.83	\$ 5,445.83	\$ 5,473.06	\$ 5,500.29	\$ 5,527.52	\$ 5,554.75	\$ 5,581.97	\$ 5,609.20	\$ 5,622.82	\$ 5,636.43	\$ 5,650.05	\$ 5,663.66
Insurance	\$ 10,179.72	\$ 10,738.56	\$ 10,738.56	\$ 10,738.56	\$ 10,738.56	\$ 10,738.56	\$ 10,738.56	\$ 10,738.56	\$ 10,738.56	\$ 10,738.56	\$ 10,738.56	\$ 10,738.56
Total	\$ 74,975.15	\$ 75,533.99	\$ 75,857.96	\$ 76,181.94	\$ 76,505.92	\$ 76,829.90	\$ 77,153.87	\$ 77,477.85	\$ 77,639.84	\$ 77,801.83	\$ 77,963.82	\$ 78,125.80
Total Compensation %		100.75%	101.18%	101.61%	102.04%	102.47%	102.91%	103.34%	103.55%	103.77%	103.99%	104.20%
Office												
Gross Wage	\$ 211,731.00	\$ 211,731.00	\$ 212,789.66	\$ 213,848.31	\$ 214,906.97	\$ 215,965.62	\$ 217,024.28	\$ 218,082.93	\$ 218,612.26	\$ 219,141.59	\$ 219,670.91	\$ 220,200.24
Soc Sec/med	\$ 16,197.42	\$ 16,197.42	\$ 16,278.41	\$ 16,359.40	\$ 16,440.38	\$ 16,521.37	\$ 16,602.36	\$ 16,683.34	\$ 16,723.84	\$ 16,764.33	\$ 16,804.82	\$ 16,845.32
Retirement	\$ 20,914.36	\$ 20,914.36	\$ 21,018.94	\$ 21,123.51	\$ 21,228.08	\$ 21,332.65	\$ 21,437.22	\$ 21,541.80	\$ 21,594.08	\$ 21,646.37	\$ 21,698.65	\$ 21,750.94
Insurance	\$ 66,273.24	\$ 69,911.52	\$ 67,592.08	\$ 66,273.10	\$ 66,273.10	\$ 69,911.52	\$ 69,911.52	\$ 69,911.52	\$ 69,911.52	\$ 69,911.52	\$ 67,592.08	\$ 69,911.52
Total	\$ 315,116.03	\$ 318,754.31	\$ 317,679.08	\$ 317,604.32	\$ 318,848.53	\$ 323,731.16	\$ 324,975.38	\$ 326,219.59	\$ 326,841.70	\$ 327,463.80	\$ 325,766.47	\$ 328,708.02
Total Compensation %		101.15%	100.81%	100.79%	101.18%	102.73%	103.13%	103.52%	103.72%	103.92%	103.38%	104.31%
Grand Total ALL	\$ 11,222.84	\$ 13,769.78	\$ 17,317.19	\$ 22,183.57	\$ 30,688.38	\$ 35,554.76	\$ 40,421.14	\$ 42,854.34	\$ 45,287.53	\$ 45,401.28	\$ 45,401.28	\$ 50,153.91
Technology												
	2022-2023	2023-2024	2024-2025									
Gross Wage	\$ 70,000.00	\$ 72,500.00	\$ 75,000.00									
Soc Sec/med	\$ 5,355.00	\$ 5,546.25	\$ 5,737.50	3 year work agreement is up 8/31/2025								
Retirement	\$ 6,916.00	\$ 7,163.00	\$ 7,410.00									
Insurance	\$ 402.48	\$ 402.48	\$ 409.56									
Total	\$ 82,673.48	\$ 85,611.73	\$ 88,557.06									

Paras*	SPED expenditure not included in general fund expenditures or budget authority												
Gross Wage	\$ 264,683.00	\$ 264,683.00	\$ 266,006.42	\$ 267,329.83	\$ 268,653.25	\$ 269,976.66	\$ 271,300.08	\$ 272,623.49	\$ 273,285.20	\$ 273,946.91	\$ 274,608.61	\$ 275,270.32	
Soc Sec/med	\$ 20,248.25	\$ 20,248.25	\$ 20,349.49	\$ 20,450.73	\$ 20,551.97	\$ 20,653.21	\$ 20,754.46	\$ 20,855.70	\$ 20,906.32	\$ 20,956.94	\$ 21,007.56	\$ 21,058.18	
Retirement	\$ 26,144.86	\$ 26,144.86	\$ 26,275.58	\$ 26,406.31	\$ 26,537.03	\$ 26,667.75	\$ 26,798.48	\$ 26,929.20	\$ 26,994.57	\$ 27,059.93	\$ 27,125.29	\$ 27,190.65	
Insurance	\$ 40,627.15	\$ 52,961.60	\$ 52,961.60	\$ 52,961.60	\$ 52,961.60	\$ 52,961.60	\$ 52,961.60	\$ 52,961.60	\$ 52,961.60	\$ 52,961.60	\$ 52,961.60	\$ 52,961.60	
Total	\$ 351,703.26	\$ 364,037.71	\$ 365,593.09	\$ 367,148.47	\$ 368,703.85	\$ 370,259.23	\$ 371,814.61	\$ 373,369.99	\$ 374,147.68	\$ 374,925.37	\$ 375,703.06	\$ 376,480.75	
		\$ 12,334.45	\$ 13,889.83	\$ 15,445.21	\$ 17,000.59	\$ 18,555.97	\$ 20,111.35	\$ 21,666.73	\$ 22,444.42	\$ 23,222.11	\$ 23,999.80	\$ 24,777.49	
Total Compensation %		103.51%	103.95%	104.39%	104.83%	105.28%	105.72%	106.16%	106.38%	106.60%	106.82%	107.05%	

Nutrition Services Wage Survey 2024-25

School Name	Starting Wage	Highest Wage Reported
Keya Paha	\$14.20	\$14.20
Arcadia	\$12.00	\$12.00
Shickley	\$16.00	\$16.00
Cody-Kilgore	\$15.00	\$16.19
Mullen	\$15.00	\$24.60
Callaway	\$16.00	\$16.00
St. Edward	\$12.80	\$12.00
Elgin	\$15.75	\$15.75
Stuart	\$16.97	\$16.97
Emerson-Hubbard	\$15.91	\$18.62
Riverside	\$14.00	\$16.81
Randolph	\$15.55	\$17.65
Lyons-Decatur	\$10.00	\$15.00
Loup City	\$10.64	\$10.64
Arapahoe	\$15.00	\$16.40
Neligh-Oakdale	\$13.50	\$14.50
Central Valley	\$16.00	\$21.42
Johnson-Brock	\$16.44	\$16.44
Southern	\$17.00	\$19.00
Cross County	\$18.00	\$23.00
Summerland	\$16.90	\$16.90
Cedar Bluffs	\$14.86	\$20.76
Doniphan-Trumball	\$14.23	\$16.25
Elmwood-Murdock	\$14.00	\$16.07
Ord	\$13.00	\$16.25
St. Paul	\$12.73	\$15.57
Arlington	\$14.04	\$19.51
Minden	\$17.00	\$22.55
Central City	\$14.00	\$14.00
Falls City	\$14.08	\$16.00
Fairbury	\$15.00	\$19.76
District 145 - Waverly	\$15.84	\$22.38
Ralston Public Schools	\$17.45	\$17.45

Average	\$14.81	\$17.17
Ravenna	\$13.52	\$15.34
Difference from Average	\$1.29	\$1.83

Student Count
90
126
154
157
165
180
183
200
201
223
251
252
305
317
321
333
339
359
374
380
438
469
478
519
587
652
709
781
815
902
908
2134
3409

12 School Average of Schools Nearest in Size to Ravenna

Lyons-Decatur	\$10.00	\$15.00	305
Loup City	\$10.64	\$10.64	317
Arapahoe	\$15.00	\$16.40	321
Neligh-Oakdale	\$13.50	\$14.50	333
Central Valley	\$16.00	\$21.42	339
Johnson-Brock	\$16.44	\$16.44	359
Southern	\$17.00	\$19.00	374
Cross County	\$18.00	\$23.00	380
Summerland	\$16.90	\$16.90	438
Cedar Bluffs	\$14.86	\$20.76	469
Doniphan-Trumball	\$14.23	\$16.25	478
Elmwood-Murdock	\$14.00	\$16.07	519

Average	\$14.71	\$17.20
Ravenna	\$13.52	\$15.34
Difference from Average	\$1.19	\$1.86



Nebraska Public Power District

Always there when you need us

120 Chadron St
Box 551
Chadron, NE 69337-0551
1-877-ASK-NPPD (1-877-275-6773)

TO:
 Ravenna Public School

 Ravenna, NE 68869

Date	04/03/25
Customer Acct #	
SAP/Serv/Work Order #	
Customer PO #	

ATTENTION: PLEASE DO NOT PAY FROM THIS INVOICE.
ESTIMATE ONLY

Quantity	Description	Unit Cost	Amount
	Materials & Supplies		\$ 2,383.37
	Labor		\$ 4,581.02
	Subsistence/Travel		\$ -
	Vehicle Expense		\$ 2,222.00
	Mobile Equipment		\$ -
	Misc Charges		\$ -
	Subtotal		\$ 9,186.39
Accounting Use Only		State SalesTax	If Applicable
		City SalesTax	If Applicable
	Total		\$ 9,186.39

Issued by:

Quote

Date: March 2025

Ravenna High School

Sourcewell

Master Project: 199030, Contract Number: 041123-MSL, Expiration: 06/16/2027

Category: Sports lighting with related supplies and services

All purchase orders should note the following:
Sourcewell purchase – contract number: 041123-MSL

Quoted Price– Materials and Installation

Musco's Light-Structure System™ as described below and delivered to the job site:

Football Stadium - \$267,000.00

(360'x160', 30-foot candles, LSS, 25-year warranty, Lighting on home Bleachers)

ADDER: Show-Light® \$10,000.00

Sales tax, and Bonding are not included.

Pricing furnished is effective for 60 days unless otherwise noted and is considered confidential.

System Description –Factory-built, wired, aimed, and tested lighting system includes:

- Remote electrical component enclosures
- Pole length wire harnesses
- Factory-aimed and assembled luminaires
- UL listed as a complete system

Control-Link® Control and Monitoring System

- Control and monitoring cabinet
- Remote on/off control
- Monitoring with 24/7 customer support
- Onsite dimming (high/med/low)

Show-Light® Special Effects Package (ADDER)

- Touchscreen for onsite control of theatrical effects
- Pre-programmed theatrical lighting effects applied to facility lighting design
- 4 minutes of light show programming set to customer-supplied and licensed music
- Onsite dimming (high/med/low/blackout)

Environmental Light Control – control for neighbors and the environment

- Reduction of spill light and glare by 50% or more

Always Ready to Play – control assuring the results you expect

- Reduction of energy and maintenance costs by 40% up to 85% over typical 1500W HID equipment
- Product assurance and warranty program that includes materials and onsite labor, eliminating 100% of your maintenance costs for **25 years** on (4) 70' Musco poles.



Quote

Date: March 2025

Ravenna High School

Payment Terms

Musco's Credit Department will provide payment terms.

Email or fax a copy of the Purchase Order to Musco Sports Lighting, LLC: Musco's Credit Department will provide payment terms.

Musco Sports Lighting, LLC

Fax: 800-374-6402

Email: musco.contracts@musco.com

Delivery Timing

8 - 12 weeks for delivery of materials to the job site from the time of order, submittal approval, and confirmation of order details including voltage, phase, and pole locations.

Due to the built-in custom light control per luminaire, pole locations need to be confirmed prior to production. Changes to pole locations after the product is sent to production could result in additional charges.

Notes

- Shipment of the entire project together to one location
- Based on 480 Volt 3 Phase electrical system requirement (*can be changed*)
- Structural code and wind speed = 2018 IBC, 115MPH Wind Zone and exposure: C
- The owner is responsible for getting electrical power to the site, coordination with the utility, and any power company fees
- This is assuming power is adequate and readily available
- **Based on Standard soil conditions – rock, bottomless, wet or unsuitable soil may require additional engineering, special installation methods and additional cost**
- Confirmation of pole locations prior to production
- Musco is the General Contractor
- Sales representative will be present

Thank you for considering our team for your sports lighting needs. Please contact me with any questions.

Brad Thompson

Musco Sales Representative

Musco Sports Lighting, LLC

Phone: 641.660.9554

E-mail: Brad.Thompson@musco.com

Project #214457



Inspection							
Inspector	Date	Time	Company	Inst. year	Age	Class	Latitude
AN	3/14/2025	7:59:25 AM	Ravana Public S	1960	65	Class 3	41.03006363
AN	3/14/2025	8:02:12 AM	Ravana Public S	1960	65	Class 3	41.02954102
AN	3/14/2025	8:04:06 AM	Ravana Public S	1999	26	Class 3	41.02954102

Pole data

Longitude	Span [ft]	Circumference [in]	Height [ft]	Species	Preservative
-98.92117310	348	44	60	South. yellow pine	Creosote full length
-98.92063141	348	44	60	South. yellow pine	Creosote full length
-98.92117310	348	44	60	South. yellow pine	Penta. full length

Environment			Defects		
Temperature [°F]	Soil type	Soil condition	Pole inclination [ft]	Sum diam. knots [in]	Depth surf. decay [in]
	Normal	Dry			0.50
	Normal	Dry			0.75
	Normal	Dry			

Mech. dam. depth [in]	Defects	General			Measurement 1			
		Count	Serial	ID	Force	Moisture	Strength [PSI]	Analysis
		2	PX05-0	PX046164	152	20	4885	
		2	PX05-0	PX046166	96	35	3426	
		2	PX05-0	PX046168	160	22	6130	

Polux measurements

Measurement 2

Result	ID	Force	Moisture	Strength [PSI]	Analysis	Result	Nominal [PSI]
Green	PX046163	120	28	4264		Orange	7200
Red	PX046165	117	28	3846		Orange	7200
Green	PX046167	160	35	6040		Green	7200

Result					Remarks	
Residual strength [PSI] (without defects)	Ratio	Residual strength [PSI] (with defects)	Ratio	Inspector result		
	4967	69 %	4574	64 %	Red	
	4393	61 %	3566	50 %	Red	
	6085	85 %	6085	85 %	Green	

Pictures

ENSLEY ELECTRICAL SERVICES

P.O. Box 5822
Grand Island, NE 68802
308-382-8432

April, 11, 2025

RE: Ravenna Public Schools Football Field Lighting
Ravenna, NE

Scope of Work:

- Remove existing sports lighting fixtures and poles and haul off.
- Install (4) Musco Sports Lighting Poles and associated fixtures.
- Directional Bore new conduit and wiring to each pole.
- Install new branch circuit breakers in existing panel for Musco System
- Included in pricing: Materials, labor, and equipment for the above scope of work.
- Install conduit and cable for Show Lighting
- Musco Poles, Fixtures, and Show-Light adder
- Bonding is Provided

Project Cost Using Musco Sports Lighting System: \$264,000.00

Requested Pricing from SLG Lighting as of 4/11/2025 did not receive a quote

Not Included:

Utility Fees (Existing Panel Is Adequately Sized for New Sports Lighting)
Taxes (Will need Tax Exempt Paperwork from School District)

Respectfully Submitted

Ensley Electrical Services

Greg Hanna



Date 04/14/2025

Attention: Ken Schroeder Ravenna Public Schools

Reference: Football Field Lighting

We propose to provide the necessary materials, labor, equipment, and tools to perform the electrical scope of work on the football field lighting as described in this proposal for the sum of:

Base Bid Musco <i>(and 00/100 US Dollars)</i>	\$280,027.00
<u>Alternate</u>	
Ephesus Lighting (similar to Musco)	\$265,535.00
Aeon Lighting (direct bury steel pole)	\$163,174.00
Wood Pole option (don't have quotes yet)	

Please reference our attached Clarifications, Inclusions, Exclusions, Terms and Conditions for additional information. We appreciate the opportunity to work with your team on this project.

If you have any questions or need any additional information, please do not hesitate to contact me.

Bruce Hueftle
Senior Estimator
IES Commercial Inc.
120 South Lincoln
Holdrege, NE 68949
P: (308) 995-4462
F: (308) 995-8771
C: (308) 991-8542
bruce.hueftle@iesci.net
www.iesci.net



Clarifications, Inclusions, and Exclusions

Clarifications

1. Pricing based on the following documents: Site visit and lighting layout/specifications by lighting representatives
2. Work to be done during normal business hours.
3. This price is based on previously discussed construction schedule of TBD (or mutually agreed upon) and excludes costs stemming from deviations from the schedule at bid time.
4. This quote is based on copper and aluminum COMEX pricing at \$4.51/lb and 1" IMC is \$259.47 per 100'. Quote subject to change at the time of purchase on these materials. Any and all escalations on materials due to price increases and tariff taxes are excluded. [The proposal price shall be adjusted to take into account any increase in cost resulting from a change in the laws of the country \(including the introduction of new laws and the repeal or modification of existing laws and/or tariffs\) or in the judicial or official governmental interpretation or implementation of such laws, made after the proposal date, which adversely affect IES in the performance of obligations under the contract.](#)
5. Sufficient storage space will be provided at no cost to IES to store material and equipment.
6. If performance and payment Bond is required add 1% to base bid.
7. Pricing firm on the date of proposal only.
8. This quote is conditioned upon the use of a contract acceptable to IES.
9. IES reserves the right to modify or negotiate the final contract.
10. New Poles will be in new locations behind the track
11. Lighting will be LED lights

Inclusions

1. Sales tax at a rate of exempt.
2. Electrical permits and fees.
3. All trenching for electrical under normal digging conditions (Removal of boulders, concrete, or any other unforeseen materials other than dirt not included).
4. Boring from existing pole locations to a new locations
5. Quazite boxes at existing poles locations to splice conductors
6. MUSCO Lighting has concrete in-bedded pole base. The balance of the pole slips over the top
7. Demo/removals of existing poles to the east side of the football field.



Exclusions

1. Utility Company, Electrical Service Provider, and Telephone Service Provider's fees and charges.
2. Consequential damages, direct damages, indirect damages, liquidated damages, or economic loss of any kind.
3. Energized Electrical Hot work.
4. Demolition.
5. Dewatering.
6. Landscaping.
7. Cutting and Patching of concrete, asphalt, gypsum board, and all other surfaces.
8. All formed concrete.
9. Painting.
10. Handling or disposing of hazardous materials.
11. Final cleaning for owner occupation. We will clean up our construction materials per our normal practice and dispose of waste to construction containers or trash facilities provided by others.
12. All roof patching and repairs.
13. Certified payrolls, prevailing wages, and/or Davis-Bacon wages (unless a federal project).
14. Any damage to the track and or football field. We will lay planks (mats) over each but the weight of our equipment may damage.

Terms and Conditions:

1. Our pricing reflects sufficient allotment of time for installation of electrical systems, before placement of but not limited to concrete slabs, wall or ceiling covering.
2. All equipment furnished by the owner or other contractors must be supplied with all necessary accessories (i.e.-fuses, lamps, thermal overloads, circuit breakers, etc...), supplied in a timely manner, and comply with all required codes.
3. This proposal is based upon a material and workmanship warranty of one year
4. Written notification of acceptance of this proposal prior to any contractual performance by IES.
5. IES will not indemnify, defend, hold harmless the owner, general contractor, or other parties for their negligence.
6. This proposal excludes the assumption of risk of nonpayment to the general contractor.
7. This proposal excludes scheduled overtime due to delays in work caused by other trades.
8. Under no circumstances shall Bidder be liable for consequential damages arising from this work.



9. Payments shall be made each thirty days as the work progresses. The entire amount of the contract shall be paid within thirty days after completion.
10. Service and Finance Charges are applicable on past due accounts at the rate of 1 ½ percent per month on amounts thirty (30) days past due, which is equal to an annual percentage rate of 18 percent. Such charges are shown as "service charges".
11. Any alteration or deviation from the above specifications involving extra cost of material and/or labor will only be executed upon written orders for same and will become an extra charge over the sum mentioned in this contract. All agreements must be made in writing.
12. The contractual agreement from acceptance of this Proposal is to be based on the AIA Document A401-2017 Standard Form of Agreement Between Contractor and Subcontractor. All terms and conditions of this Proposal are to be incorporated by reference in such Agreement. "It is IES policy not to accept consequential damages, indirect damages, or liability for economic loss of any kind." IES reserves the right to modify or negotiate these terms from our contracts.
13. To the extent IES's scope of work is delayed or otherwise impacted due to events outside of IES's control, including but not limited to Acts of God, epidemics, pandemics and/or global health emergencies, illness of Contractor's workforce, global supply chain issues, restrictions on activities or travel by any local, county, state or federal governmental order and/or unavailability of labor, materials, supplies, parts or other products due to such events, IES will be entitled to an adjustment in the contract schedule and potentially contract pricing should any schedule adjustment or impact on materials and equipment availability impact IES's costs to perform its scope as originally bid
14. **Note: This Proposal may be withdrawn by us if not accepted within 7 days of proposal date.**

Ravenna High School Football

Ravenna, NE

Lighting System

Pole/Fixture Summary						
Pole ID	Pole Height	Mtg Height	Fixture Qty	Luminaire Type	Load	Circuit
F1-F2	70'	70'	6	TLC-LED-1200	7.02 kW	A
		55'	1	TLC-LED-550	0.54 kW	A
		16'	2	TLC-BT-575	1.15 kW	A
F3-F4	70'	70'	6	TLC-LED-1200	7.02 kW	A
		16'	2	TLC-BT-575	1.15 kW	A
4			34		33.76 kW	

Circuit Summary			
Circuit	Description	Load	Fixture Qty
A	Football	33.76 kW	34

Fixture Type Summary							
Type	Source	Wattage	Lumens	L90	L80	L70	Quantity
TLC-BT-575	LED 5700K - 75 CRI	575W	52,000	>120,000	>120,000	>120,000	8
TLC-LED-1200	LED 5700K - 75 CRI	1170W	150,000	>120,000	>120,000	>120,000	24
TLC-LED-550	LED 5700K - 75 CRI	540W	67,000	>120,000	>120,000	>120,000	2

Single Luminaire Amperage Draw Chart								
Driver Specifications (.90 min power factor)	Line Amperage Per Luminaire (max draw)							
	208 (60)	220 (60)	240 (60)	277 (60)	347 (60)	380 (60)	480 (60)	
Single Phase Voltage								
TLC-LED-1200	6.9	6.5	6.0	5.2	4.2	3.8	3.0	
TLC-BT-575	3.3	3.2	2.9	2.5	2.0	1.8	1.5	
TLC-LED-550	3.2	3.0	2.8	2.4	1.9	1.8	1.4	

Light Level Summary

Calculation Grid Summary								
Grid Name	Calculation Metric	Illumination Ave					Circuits	Fixture Qty
		Ave	Min	Max	Max/Min	Ave/Min		
150' Glare @ 5ft.	Max Candela (by Fixture)	367.2969	0.00	959.64	-	-	A	34
150' Spill @ 3ft.	Horizontal Illuminance	0.0037	0.00	0.02	-	-	A	34
150' Spill @ 5ft.	Max Vertical Illuminance Metric	0.0094	0.00	0.05	-	-	A	34
8-Man Football	Horizontal Illuminance	35.58	34	38	1.13	1.05	A	34
Bleacher	Horizontal	17.36	7	25	3.49	2.46	A	34
Field	Horizontal	34.98	28	39	1.40	1.25	A	34
Residential Property Line Glare @ 5ft.	Max Candela (by Fixture)	1740.0367	21.10	5049.61	239.348	82.477	A	34
Residential Property Line Spill @ 3ft.	Horizontal Illuminance	0.0449	0.00	0.33	957.039	131.617	A	34
Residential Property Line Spill @ 5ft.	Max Vertical Illuminance Metric	0.0832	0.00	0.47	838.738	147.022	A	34
Track	Horizontal Illuminance	15.24	5	28	5.87	3.15	A	34

From Hometown to Professional

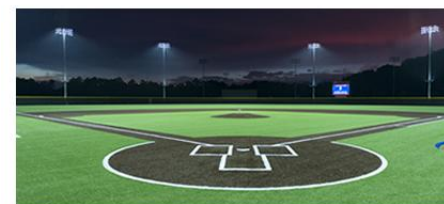

We Make It Happen.

Not to be reproduced in whole or part without the written consent of Musco Sports Lighting, LLC. ©1981, 2025 Musco Sports Lighting, LLC.

Equipment List For Areas Shown								
Pole				Luminaires				
QTY	LOCATION	SIZE	GRADE ELEVATION	ABOVE GRADE LEVEL	LUMINAIRE TYPE	QTY/POLE	THIS GRID	OTHER GRIDS
2	F1-F2	70'	-	70'	TLC-LED-1200	6	6	0
				55'	TLC-LED-550	1	1	0
				15.5'	TLC-BT-575	2	2	0
2	F3-F4	70'	-	70'	TLC-LED-1200	6	6	0
				15.5'	TLC-BT-575	2	2	0
4	Totals					34	34	0

*Above Grade level relative to the field

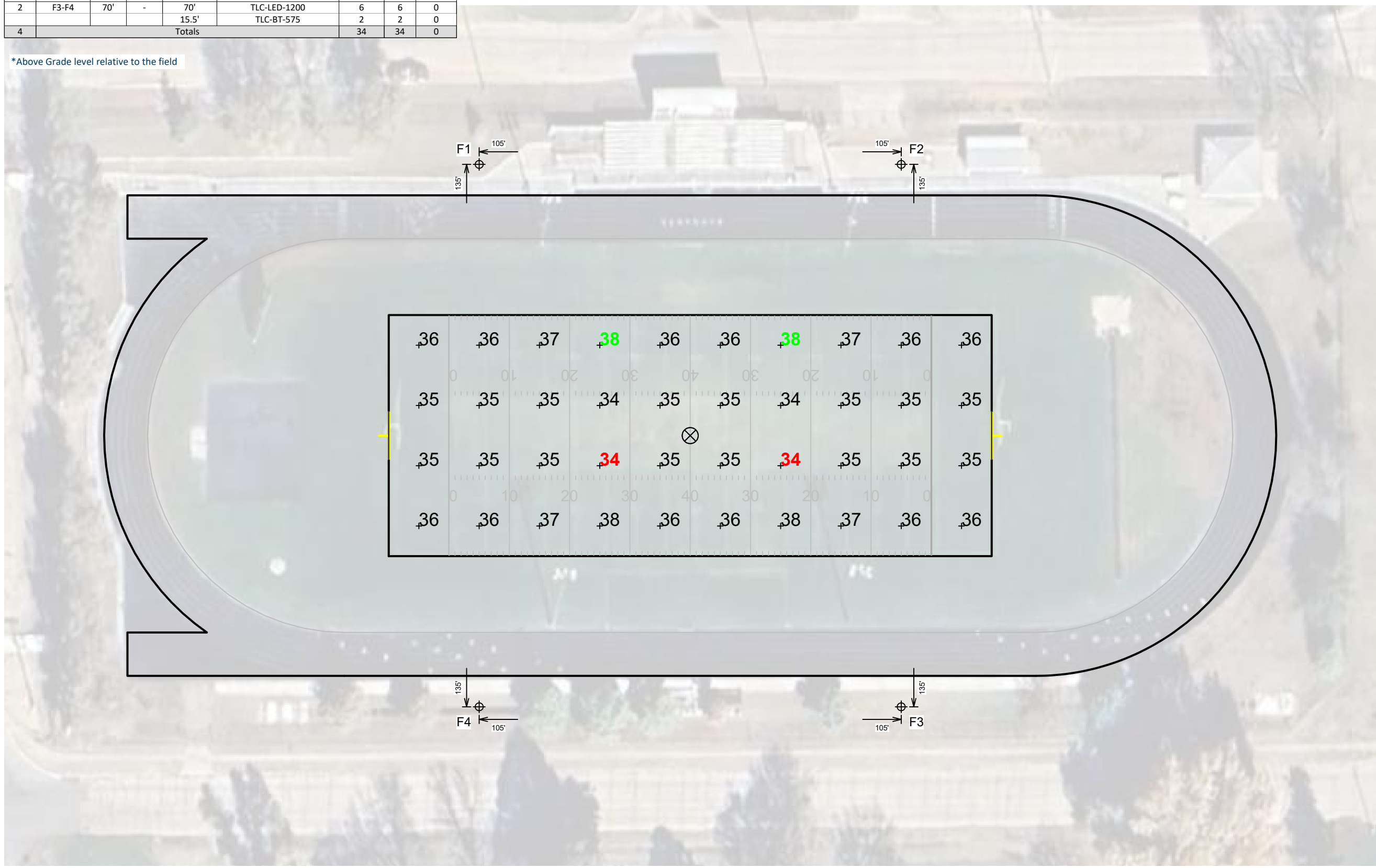

Ravenna High School Football

Ravenna, NE

Grid Summary	
Name:	8-Man Football
Size:	300' x 120'
Spacing:	30.0' x 30.0'
Height:	3.0' above grade

Illumination Summary	
MAINTAINED HORIZONTAL FOOTCANDLES	
Entire Grid	
Guaranteed Average:	30
Scan Average:	35.58
Maximum:	38
Minimum:	34
Avg/Min:	1.05
Guaranteed Max/Min:	2.5
Max/Min:	1.13
UG (adjacent pts):	1.13
CU:	0.31
No. of Points:	40
LUMINAIRE INFORMATION	
Applied Circuits:	A
No. of Luminaires:	34
Total Load:	33.76 kW

Guaranteed Performance: The ILLUMINATION described above is guaranteed per your Musco Warranty document and includes a 0.95 dirt depreciation factor.

Field Measurements: Individual field measurements may vary from computer-calculated predictions and should be taken in accordance with IESNA RP-6-15.

Electrical System Requirements: Refer to Amperage Draw Chart and/or the "Musco Control System Summary" for electrical sizing.

Installation Requirements: Results assume ± 3% nominal voltage at line side of the driver and structures located within 3 feet (1m) of design locations.

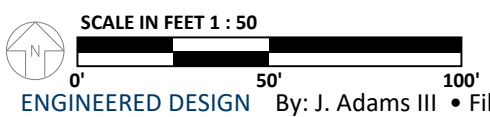

ENGINEERED DESIGN By: J. Adams III • File #214457A • 02-Apr-25

Pole location(s) ⊕ dimensions are relative to 0,0 reference point(s) ⊗



We Make It Happen.

Not to be reproduced in whole or part without the written consent of Musco Sports Lighting, LLC. ©1981, 2025 Musco Sports Lighting, LLC.

ILLUMINATION SUMMARY

Equipment List For Areas Shown								
Pole				Luminaires				
QTY	LOCATION	SIZE	GRADE ELEVATION	ABOVE GRADE LEVEL	LUMINAIRE TYPE	QTY/POLE	THIS GRID	OTHER GRIDS
2	F1-F2	70'	-	70'	TLC-LED-1200	6	6	0
				55'	TLC-LED-550	1	1	0
				15.5'	TLC-BT-575	2	2	0
2	F3-F4	70'	-	70'	TLC-LED-1200	6	6	0
				15.5'	TLC-BT-575	2	2	0
4	Totals					34	34	0

*Above Grade level relative to the field

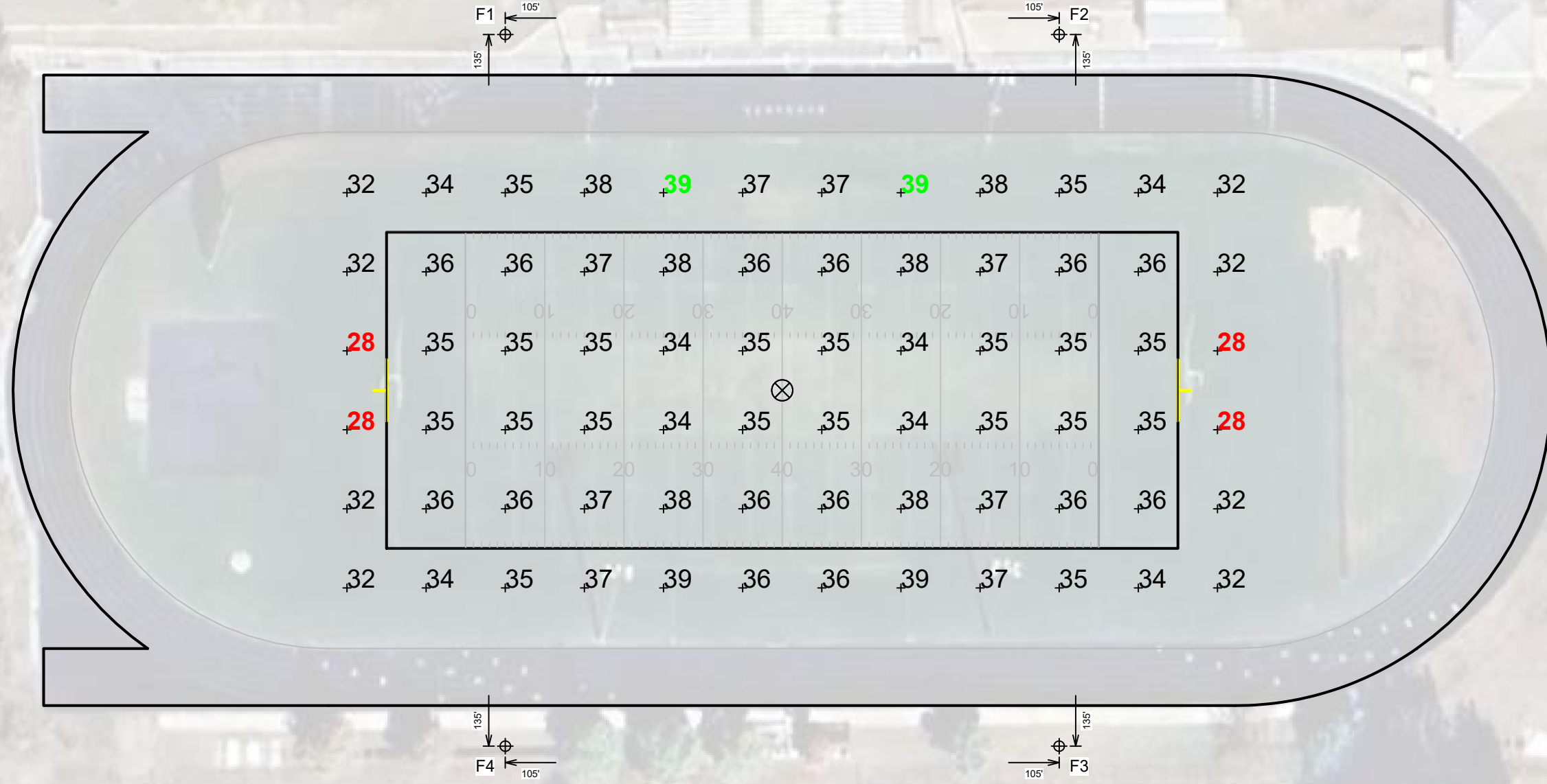

Ravenna High School Football

Ravenna, NE

Grid Summary	
Name:	Field
Size:	300' x 120'
Spacing:	30.0' x 30.0'
Height:	3.0' above grade

Illumination Summary	
MAINTAINED HORIZONTAL FOOTCANDLES	
Entire Grid	
Scan Average:	34.98
Maximum:	39
Minimum:	28
Avg/Min:	1.25
Max/Min:	1.40
UG (adjacent pts):	1.24
CU:	0.54
No. of Points:	72
LUMINAIRE INFORMATION	
Applied Circuits:	A
No. of Luminaires:	34
Total Load:	33.76 kW

Guaranteed Performance: The ILLUMINATION described above is guaranteed per your Musco Warranty document and includes a 0.95 dirt depreciation factor.

Field Measurements: Individual field measurements may vary from computer-calculated predictions and should be taken in accordance with IESNA RP-6-15.

Electrical System Requirements: Refer to Amperage Draw Chart and/or the "Musco Control System Summary" for electrical sizing.

Installation Requirements: Results assume ± 3% nominal voltage at line side of the driver and structures located within 3 feet (1m) of design locations.

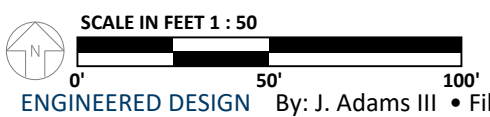

ENGINEERED DESIGN By: J. Adams III • File #214457A • 02-Apr-25

Pole location(s) ⊕ dimensions are relative to 0,0 reference point(s) ⊗



We Make It Happen.

Not to be reproduced in whole or part without the written consent of Musco Sports Lighting, LLC. ©1981, 2025 Musco Sports Lighting, LLC.

ILLUMINATION SUMMARY

Equipment List For Areas Shown								
Pole				Luminaires				
QTY	LOCATION	SIZE	GRADE ELEVATION	ABOVE GRADE LEVEL	LUMINAIRE TYPE	QTY/POLE	THIS GRID	OTHER GRIDS
2	F1-F2	70'	-	70'	TLC-LED-1200	6	6	0
				55'	TLC-LED-550	1	1	0
				15.5'	TLC-BT-575	2	2	0
2	F3-F4	70'	-	70'	TLC-LED-1200	6	6	0
				15.5'	TLC-BT-575	2	2	0
4	Totals					34	34	0

*Above Grade level relative to the field

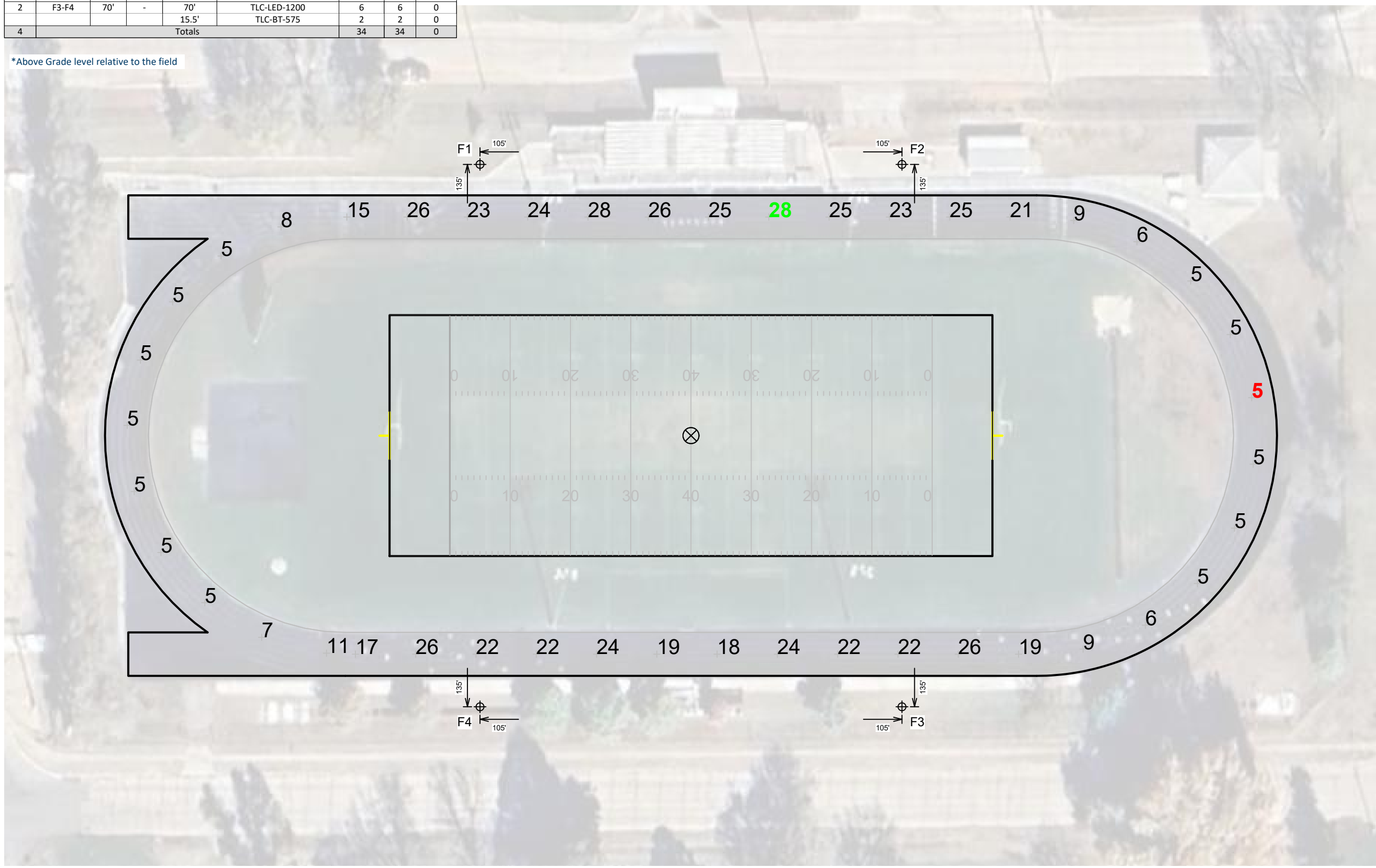

Ravenna High School Football

Grid Summary	
Name:	Track
Size:	Irregular
Spacing:	30.0' x 30.0'
Height:	3.0' above grade

Illumination Summary	
MAINTAINED HORIZONTAL FOOTCANDLES	
Entire Grid	
Scan Average:	15.24
Maximum:	28
Minimum:	5
Avg/Min:	3.15
Max/Min:	5.87
UG (adjacent pts):	0.00
CU:	0.14
No. of Points:	44
LUMINAIRE INFORMATION	
Applied Circuits:	A
No. of Luminaires:	34
Total Load:	33.76 kW

Guaranteed Performance: The ILLUMINATION described above is guaranteed per your Musco Warranty document and includes a 0.95 dirt depreciation factor.

Field Measurements: Individual field measurements may vary from computer-calculated predictions and should be taken in accordance with IESNA RP-6-15.

Electrical System Requirements: Refer to Amperage Draw Chart and/or the "Musco Control System Summary" for electrical sizing.

Installation Requirements: Results assume ± 3% nominal voltage at line side of the driver and structures located within 3 feet (1m) of design locations.

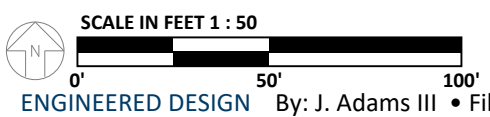

ENGINEERED DESIGN By: J. Adams III • File #214457A • 02-Apr-25

Pole location(s) ⊕ dimensions are relative to 0,0 reference point(s) ⊗



We Make It Happen.

Not to be reproduced in whole or part without the written consent of Musco Sports Lighting, LLC. ©1981, 2025 Musco Sports Lighting, LLC.

ILLUMINATION SUMMARY

Equipment List For Areas Shown								
Pole				Luminaires				
QTY	LOCATION	SIZE	GRADE ELEVATION	ABOVE GRADE LEVEL	LUMINAIRE TYPE	QTY/POLE	THIS GRID	OTHER GRIDS
2	F1-F2	70'	-	70'	TLC-LED-1200	6	6	0
				55'	TLC-LED-550	1	1	0
				15.5'	TLC-BT-575	2	2	0
2	F3-F4	70'	-	70'	TLC-LED-1200	6	6	0
				15.5'	TLC-BT-575	2	2	0
4	Totals					34	34	0

*Above Grade level relative to the field

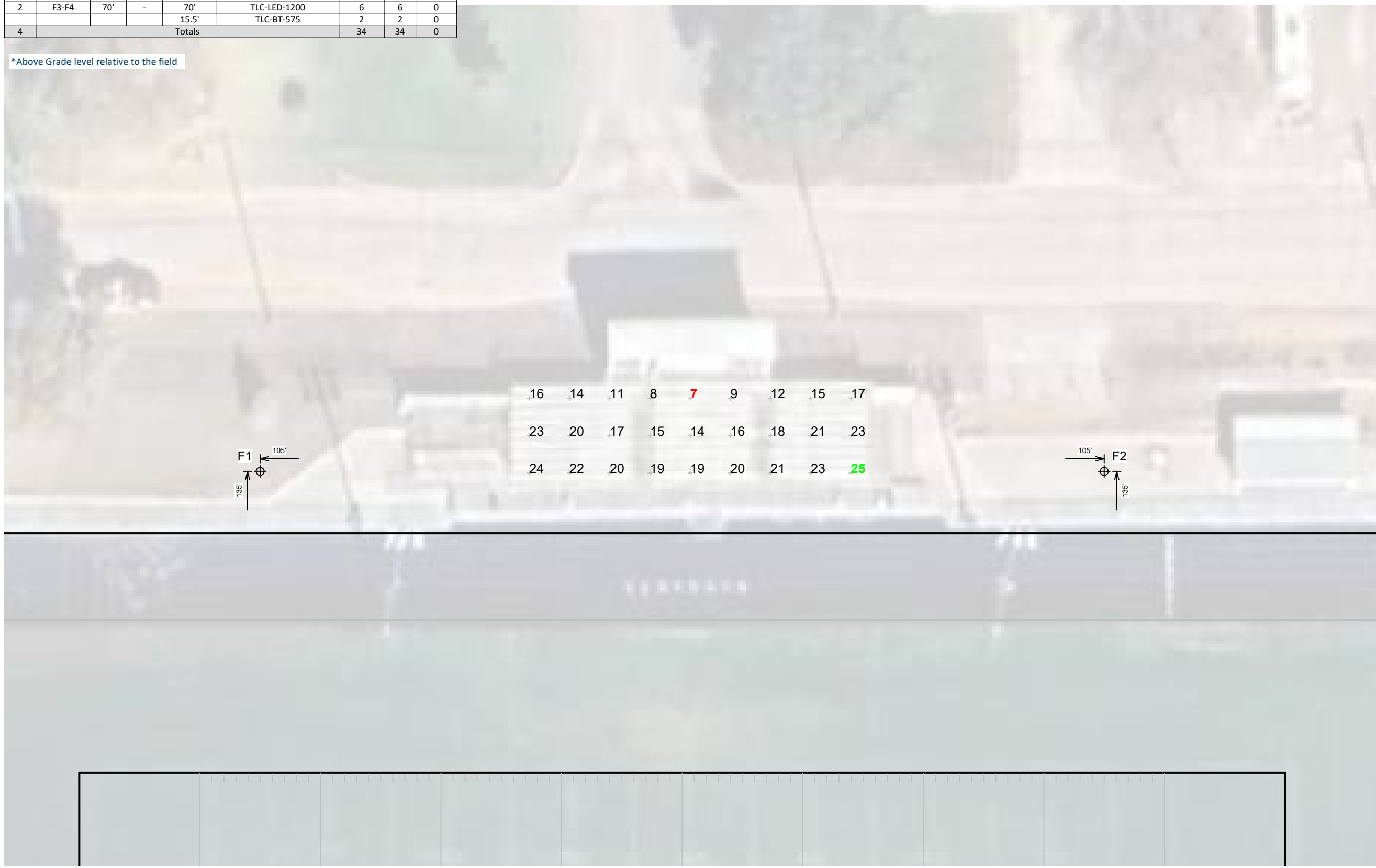

16	14	11	8	7	9	12	15	17
23	20	17	15	14	16	18	21	23
24	22	20	19	19	20	21	23	25

Ravenna High School Football

Ravenna, NE

Grid Summary	
Name:	Bleacher
Size:	Irregular
Spacing:	10.0' x 10.0'

Illumination Summary	
MAINTAINED HORIZONTAL FOOTCANDLES	
Entire Grid	
Scan Average:	17.36
Maximum:	25
Minimum:	7
Avg/Min:	2.46
Max/Min:	3.49
UG (adjacent pts):	1.97
CU:	0.01
No. of Points:	27
LUMINAIRE INFORMATION	
Applied Circuits:	A
No. of Luminaires:	34
Total Load:	33.76 kW

Guaranteed Performance: The ILLUMINATION described above is guaranteed per your Musco Warranty document and includes a 0.95 dirt depreciation factor.

Field Measurements: Individual field measurements may vary from computer-calculated predictions and should be taken in accordance with IESNA RP-6-15.

Electrical System Requirements: Refer to Amperage Draw Chart and/or the "Musco Control System Summary" for electrical sizing.

Installation Requirements: Results assume ± 3% nominal voltage at line side of the driver and structures located within 3 feet (1m) of design locations.

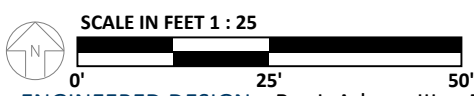

ENGINEERED DESIGN By: J. Adams III • File #214457A • 02-Apr-25

Pole location(s) ⊕ dimensions are relative to 0,0 reference point(s) ⊗



We Make It Happen.

Not to be reproduced in whole or part without the written consent of Musco Sports Lighting, LLC. ©1981, 2025 Musco Sports Lighting, LLC.

ILLUMINATION SUMMARY

Equipment List For Areas Shown								
Pole				Luminaires				
QTY	LOCATION	SIZE	GRADE ELEVATION	ABOVE GRADE LEVEL	LUMINAIRE TYPE	QTY/POLE	THIS GRID	OTHER GRIDS
2	F1-F2	70'	-	70'	TLC-LED-1200	6	6	0
				55'	TLC-LED-550	1	1	0
				15.5'	TLC-BT-575	2	2	0
2	F3-F4	70'	-	70'	TLC-LED-1200	6	6	0
				15.5'	TLC-BT-575	2	2	0
4	Totals					34	34	0

*Above Grade level relative to the field

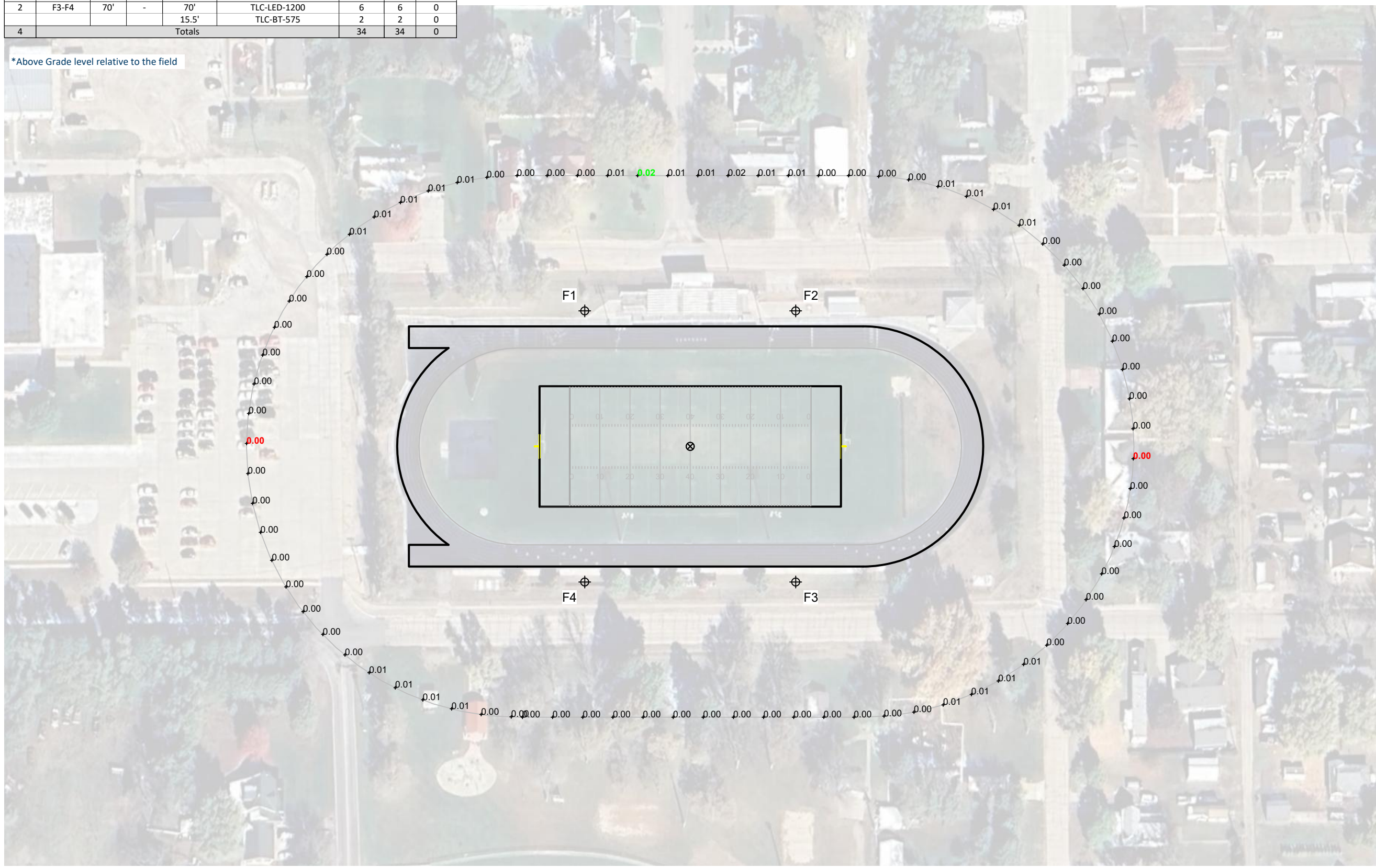

Ravenna High School Football

Ravenna, NE

Grid Summary	
Name:	150' Spill @ 3ft.
Spacing:	30.0'
Height:	3.0' above grade

Illumination Summary	
	INITIAL HORIZONTAL FOOTCANDLES
	Entire Grid
Scan Average:	0.0037
Maximum:	0.02
Minimum:	0.00
CU:	0.00
No. of Points:	80
LUMINAIRE INFORMATION	
Applied Circuits:	A
No. of Luminaires:	34
Total Load:	33.76 kW

Guaranteed Performance: The ILLUMINATION described above is guaranteed per your Musco Warranty document.

Field Measurements: Individual field measurements may vary from computer-calculated predictions and should be taken in accordance with IESNA RP-6-15.

Electrical System Requirements: Refer to Amperage Draw Chart and/or the "Musco Control System Summary" for electrical sizing.

Installation Requirements: Results assume ± 3% nominal voltage at line side of the driver and structures located within 3 feet (1m) of design locations.

SCALE IN FEET 1 : 100

 ENGINEERED DESIGN By: J. Adams III • File #214457A • 02-Apr-25

Pole location(s) ⊕ dimensions are relative to 0,0 reference point(s) ⊗



We Make It Happen.

Not to be reproduced in whole or part without the written consent of Musco Sports Lighting, LLC. ©1981, 2025 Musco Sports Lighting, LLC.

ILLUMINATION SUMMARY

Equipment List For Areas Shown								
Pole				Luminaires				
QTY	LOCATION	SIZE	GRADE ELEVATION	ABOVE GRADE LEVEL	LUMINAIRE TYPE	QTY/POLE	THIS GRID	OTHER GRIDS
2	F1-F2	70'	-	70'	TLC-LED-1200	6	6	0
				55'	TLC-LED-550	1	1	0
				15.5'	TLC-BT-575	2	2	0
2	F3-F4	70'	-	70'	TLC-LED-1200	6	6	0
				15.5'	TLC-BT-575	2	2	0
4	Totals					34	34	0

*Above Grade level relative to the field

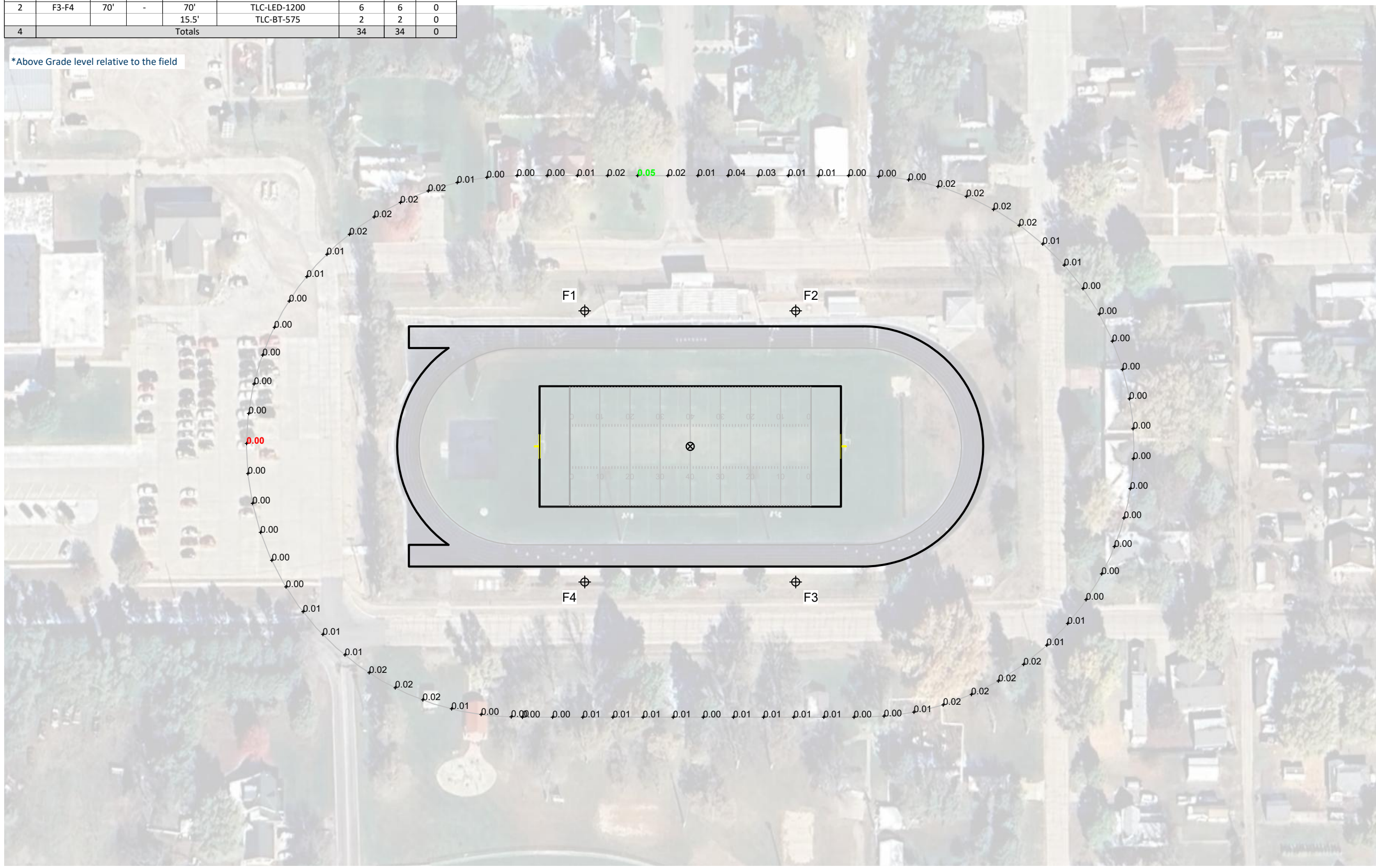

Ravenna High School Football

Grid Summary	
Name:	150' Spill @ 5ft.
Spacing:	30.0'
Height:	5.0' above grade

Illumination Summary	
	INITIAL MAX VERTICAL FOOTCANDLES
Entire Grid	
Scan Average:	0.0094
Maximum:	0.05
Minimum:	0.00
CU:	0.00
No. of Points:	80
LUMINAIRE INFORMATION	
Applied Circuits:	A
No. of Luminaires:	34
Total Load:	33.76 kW

Guaranteed Performance: The ILLUMINATION described above is guaranteed per your Musco Warranty document.

Field Measurements: Individual field measurements may vary from computer-calculated predictions and should be taken in accordance with IESNA RP-6-15.

Electrical System Requirements: Refer to Amperage Draw Chart and/or the "Musco Control System Summary" for electrical sizing.

Installation Requirements: Results assume ± 3% nominal voltage at line side of the driver and structures located within 3 feet (1m) of design locations.

SCALE IN FEET 1 : 100
 0' 100' 200'
 ENGINEERED DESIGN By: J. Adams III • File #214457A • 02-Apr-25

Pole location(s) ⊕ dimensions are relative to 0,0 reference point(s) ⊗



We Make It Happen.

Not to be reproduced in whole or part without the written consent of Musco Sports Lighting, LLC. ©1981, 2025 Musco Sports Lighting, LLC.

ILLUMINATION SUMMARY

Equipment List For Areas Shown								
Pole				Luminaires				
QTY	LOCATION	SIZE	GRADE ELEVATION	ABOVE GRADE LEVEL	LUMINAIRE TYPE	QTY/POLE	THIS GRID	OTHER GRIDS
2	F1-F2	70'	-	70'	TLC-LED-1200	6	6	0
				55'	TLC-LED-550	1	1	0
				15.5'	TLC-BT-575	2	2	0
2	F3-F4	70'	-	70'	TLC-LED-1200	6	6	0
				15.5'	TLC-BT-575	2	2	0
4	Totals					34	34	0

*Above Grade level relative to the field

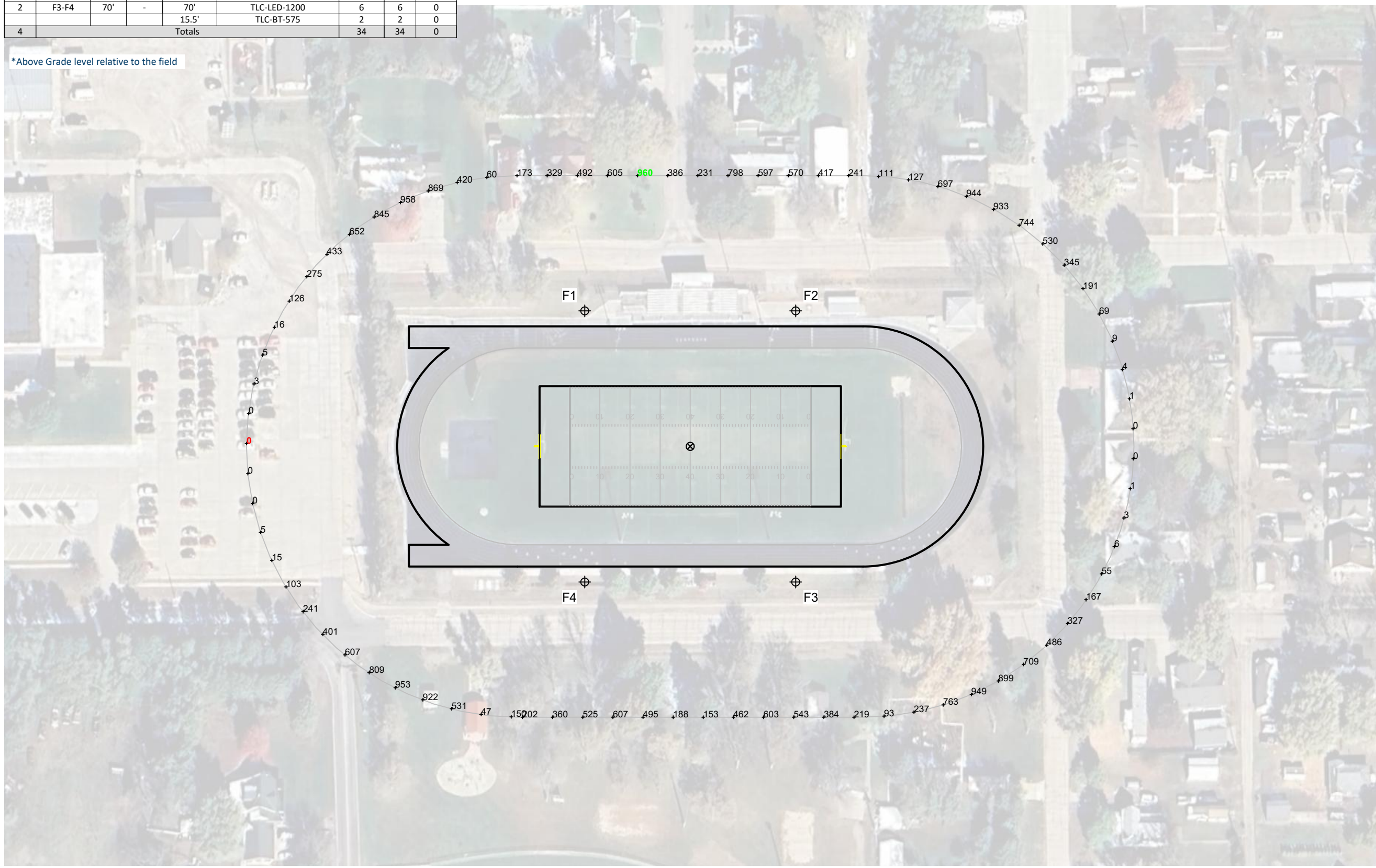

Ravenna High School Football

Ravenna, NE

Grid Summary	
Name:	150' Glare @ 5ft.
Spacing:	30.0'
Height:	5.0' above grade

Illumination Summary	
	INITIAL CANDELA (PER LIGHTBANK)
	Entire Grid
Scan Average:	367.2969
Maximum:	959.64
Minimum:	0.00
CU:	0.00
No. of Points:	80
LUMINAIRE INFORMATION	
Applied Circuits:	A
No. of Luminaires:	34
Total Load:	33.76 kW

Guaranteed Performance: The ILLUMINATION described above is guaranteed per your Musco Warranty document.

Field Measurements: Individual field measurements may vary from computer-calculated predictions and should be taken in accordance with IESNA RP-6-15.

Electrical System Requirements: Refer to Amperage Draw Chart and/or the "Musco Control System Summary" for electrical sizing.

Installation Requirements: Results assume ± 3% nominal voltage at line side of the driver and structures located within 3 feet (1m) of design locations.

Pole location(s) ⊕ dimensions are relative to 0,0 reference point(s) ⊗



We Make It Happen.

Not to be reproduced in whole or part without the written consent of Musco Sports Lighting, LLC. ©1981, 2025 Musco Sports Lighting, LLC.

ILLUMINATION SUMMARY

Equipment List For Areas Shown								
Pole				Luminaires				
QTY	LOCATION	SIZE	GRADE ELEVATION	ABOVE GRADE LEVEL	LUMINAIRE TYPE	QTY/POLE	THIS GRID	OTHER GRIDS
2	F1-F2	70'	-	70'	TLC-LED-1200	6	6	0
				55'	TLC-LED-550	1	1	0
				15.5'	TLC-BT-575	2	2	0
2	F3-F4	70'	-	70'	TLC-LED-1200	6	6	0
				15.5'	TLC-BT-575	2	2	0
4	Totals					34	34	0

*Above Grade level relative to the field

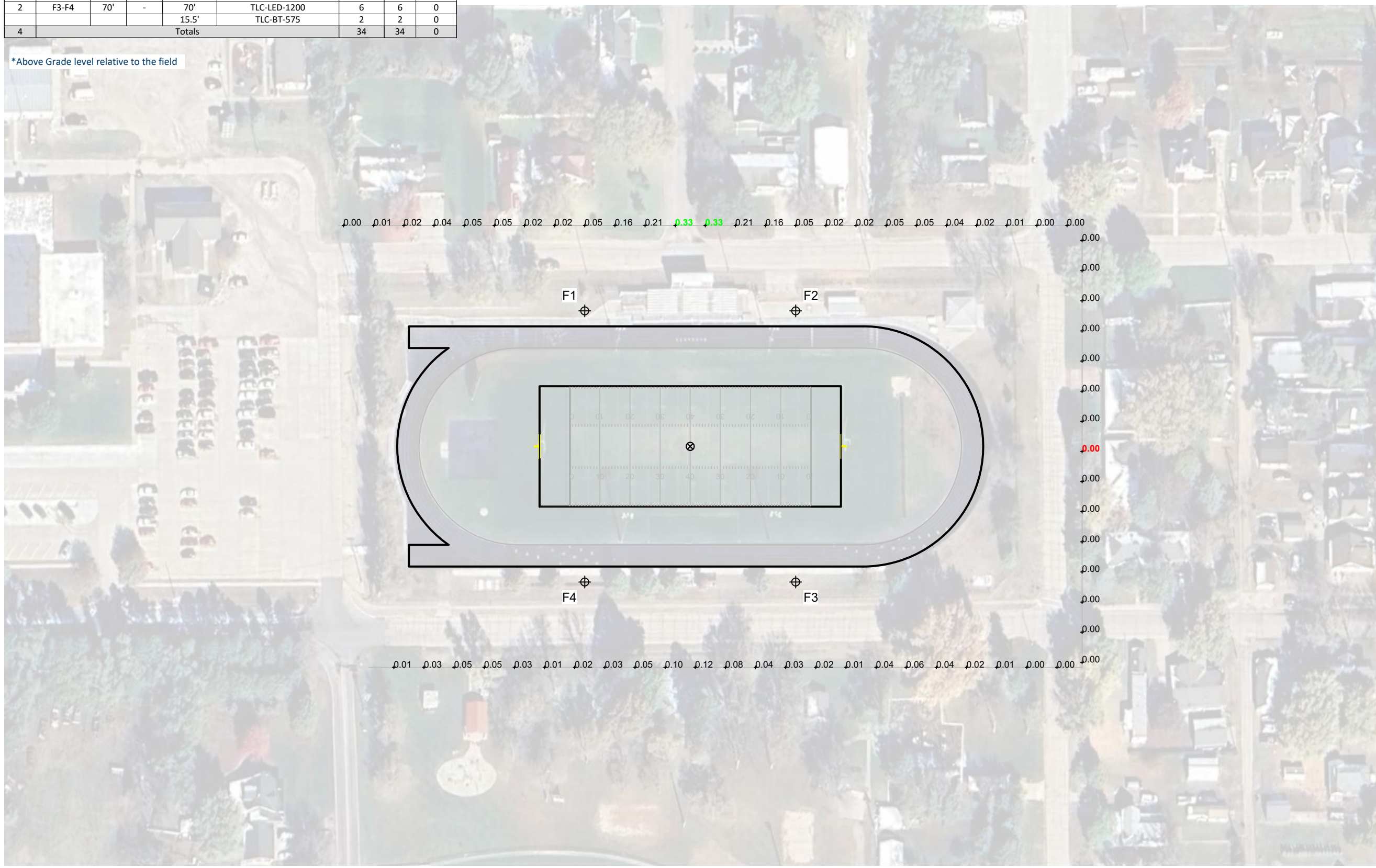

Ravenna High School Football

Ravenna, NE	
Grid Summary	
Name: Residential Property Line Spill @ 3ft.	
Spacing: 30.0'	
Height: 3.0' above grade	

Illumination Summary	
	INITIAL HORIZONTAL FOOTCANDLES
	Entire Grid
Scan Average:	0.0449
Maximum:	0.33
Minimum:	0.00
CU:	0.00
No. of Points:	63
LUMINAIRE INFORMATION	
Applied Circuits:	A
No. of Luminaires:	34
Total Load:	33.76 kW

Guaranteed Performance: The ILLUMINATION described above is guaranteed per your Musco Warranty document.

Field Measurements: Individual field measurements may vary from computer-calculated predictions and should be taken in accordance with IESNA RP-6-15.

Electrical System Requirements: Refer to Amperage Draw Chart and/or the "Musco Control System Summary" for electrical sizing.

Installation Requirements: Results assume ± 3% nominal voltage at line side of the driver and structures located within 3 feet (1m) of design locations.



Equipment List For Areas Shown								
Pole				Luminaires				
QTY	LOCATION	SIZE	GRADE ELEVATION	ABOVE GRADE LEVEL	LUMINAIRE TYPE	QTY/POLE	THIS GRID	OTHER GRIDS
2	F1-F2	70'	-	70'	TLC-LED-1200	6	6	0
				55'	TLC-LED-550	1	1	0
				15.5'	TLC-BT-575	2	2	0
2	F3-F4	70'	-	70'	TLC-LED-1200	6	6	0
				15.5'	TLC-BT-575	2	2	0
4	Totals					34	34	0

*Above Grade level relative to the field

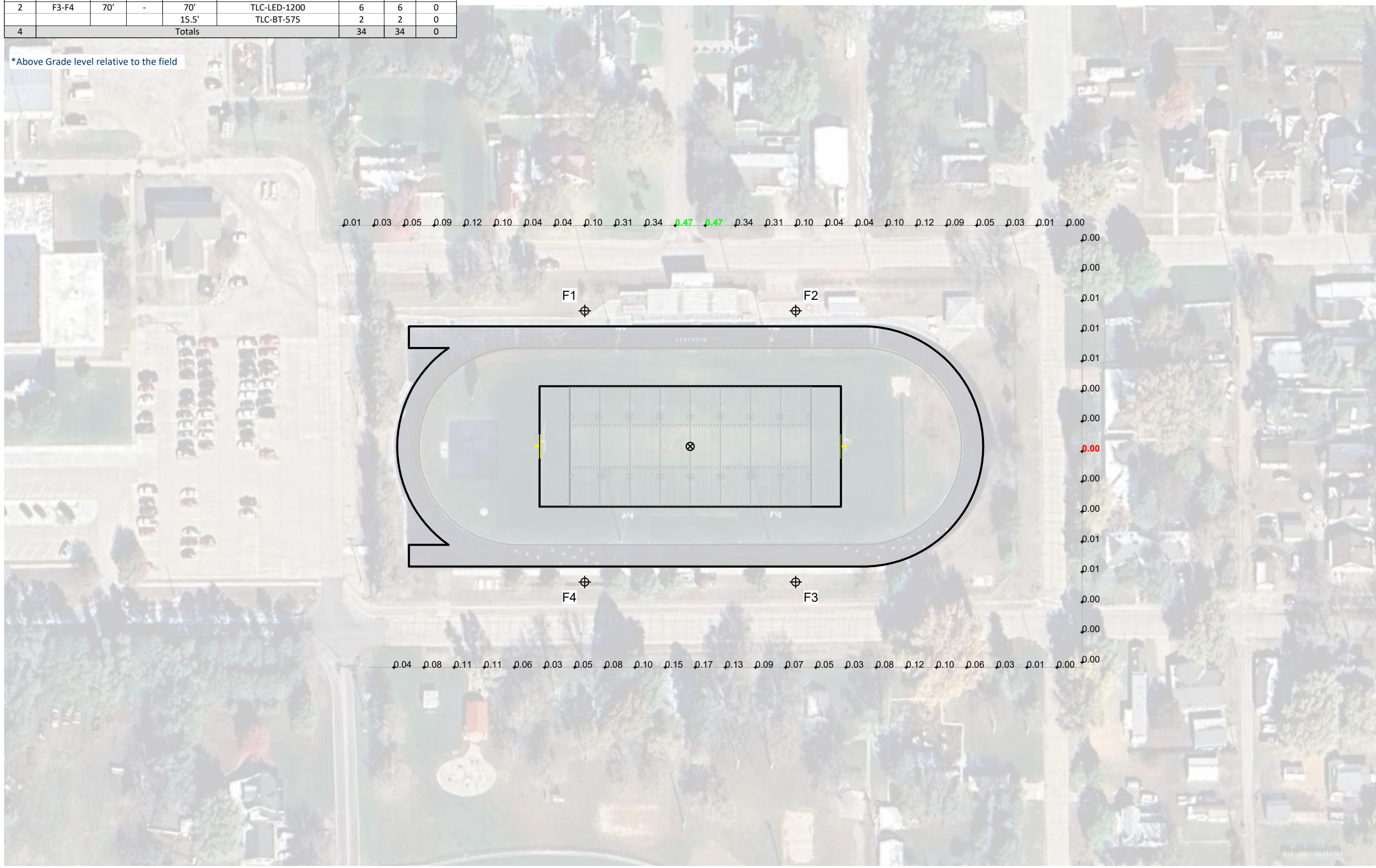

Ravenna High School Football

Ravenna, NE

Grid Summary	
Name:	Residential Property Line Spill @ 5ft.
Spacing:	30.0'
Height:	5.0' above grade

Illumination Summary	
	INITIAL MAX VERTICAL FOOTCANDLES
	Entire Grid
Scan Average:	0.0832
Maximum:	0.47
Minimum:	0.00
CU:	0.00
No. of Points:	63
LUMINAIRE INFORMATION	
Applied Circuits:	A
No. of Luminaires:	34
Total Load:	33.76 kW

Guaranteed Performance: The ILLUMINATION described above is guaranteed per your Musco Warranty document.

Field Measurements: Individual field measurements may vary from computer-calculated predictions and should be taken in accordance with IESNA RP-6-15.

Electrical System Requirements: Refer to Amperage Draw Chart and/or the "Musco Control System Summary" for electrical sizing.

Installation Requirements: Results assume ± 3% nominal voltage at line side of the driver and structures located within 3 feet (1m) of design locations.



Equipment List For Areas Shown								
Pole				Luminaires				
QTY	LOCATION	SIZE	GRADE ELEVATION	ABOVE GRADE LEVEL	LUMINAIRE TYPE	QTY/POLE	THIS GRID	OTHER GRIDS
2	F1-F2	70'	-	70'	TLC-LED-1200	6	6	0
				55'	TLC-LED-550	1	1	0
				15.5'	TLC-BT-575	2	2	0
2	F3-F4	70'	-	70'	TLC-LED-1200	6	6	0
				15.5'	TLC-BT-575	2	2	0
4	Totals					34	34	0

*Above Grade level relative to the field

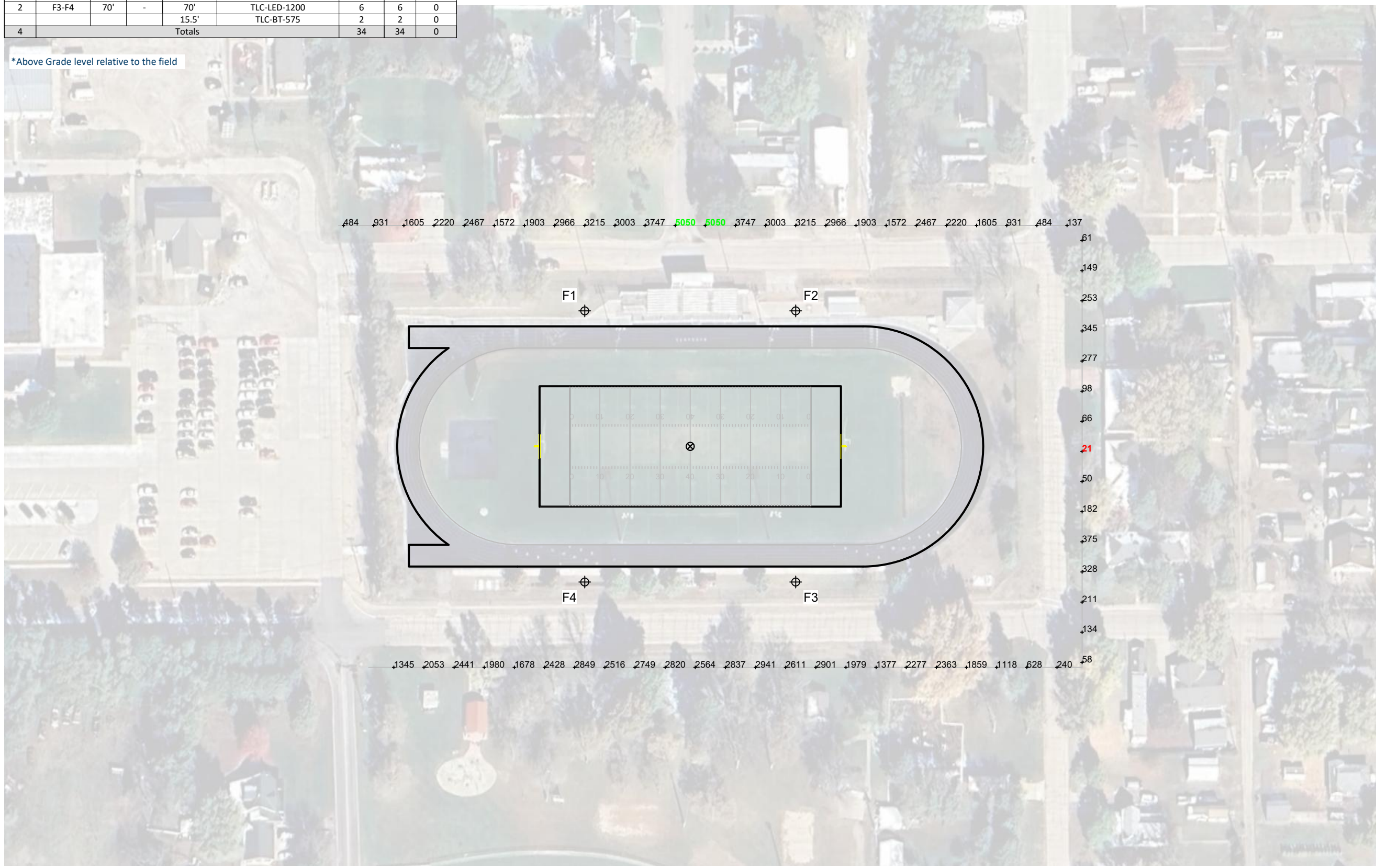

Ravenna High School Football

Ravenna, NE

Grid Summary	
Name:	Residential Property Line Glare @ 5ft.
Spacing:	30.0'
Height:	5.0' above grade

Illumination Summary	
	INITIAL CANDELA (PER LIGHTBANK)
Entire Grid	
Scan Average:	1740.0367
Maximum:	5049.61
Minimum:	21.10
CU:	0.00
No. of Points:	63
LUMINAIRE INFORMATION	
Applied Circuits:	A
No. of Luminaires:	34
Total Load:	33.76 kW

Guaranteed Performance: The ILLUMINATION described above is guaranteed per your Musco Warranty document.

Field Measurements: Individual field measurements may vary from computer-calculated predictions and should be taken in accordance with IESNA RP-6-15.

Electrical System Requirements: Refer to Amperage Draw Chart and/or the "Musco Control System Summary" for electrical sizing.

Installation Requirements: Results assume ± 3% nominal voltage at line side of the driver and structures located within 3 feet (1m) of design locations.



Ravenna High School Football

Ravenna, NE

Equipment Layout

INCLUDES:
 · Football
 · Track

Electrical System Requirements: Refer to Amperage Draw Chart and/or the "Musco Control System Summary" for electrical sizing.

Installation Requirements: Results assume ± 3% nominal voltage at line side of the driver and structures located within 3 feet (1m) of design locations.

Equipment List For Areas Shown

QTY	LOCATION	SIZE	Pole		Luminaires	
			GRADE ELEVATION	ABOVE GRADE LEVEL	LUMINAIRE TYPE	QTY/POLE
2	F1-F2	70'	-	70'	TLC-LED-1200	6
					TLC-LED-550	1
					TLC-BT-575	2
2	F3-F4	70'	-	70'	TLC-LED-1200	6
					TLC-BT-575	2
4	Totals					34

Single Luminaire Amperage Draw Chart

Driver Specifications (.90 min power factor)	Line Amperage Per Luminaire (max draw)						
	208 (60)	220 (60)	240 (60)	277 (60)	347 (60)	380 (60)	480 (60)
Single Phase Voltage	6.9	6.5	6.0	5.2	4.2	3.8	3.0
TLC-LED-1200	3.3	3.2	2.9	2.5	2.0	1.8	1.5
TLC-BT-575	3.2	3.0	2.8	2.4	1.9	1.8	1.4

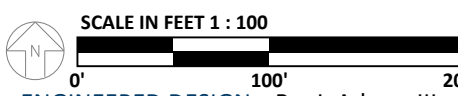
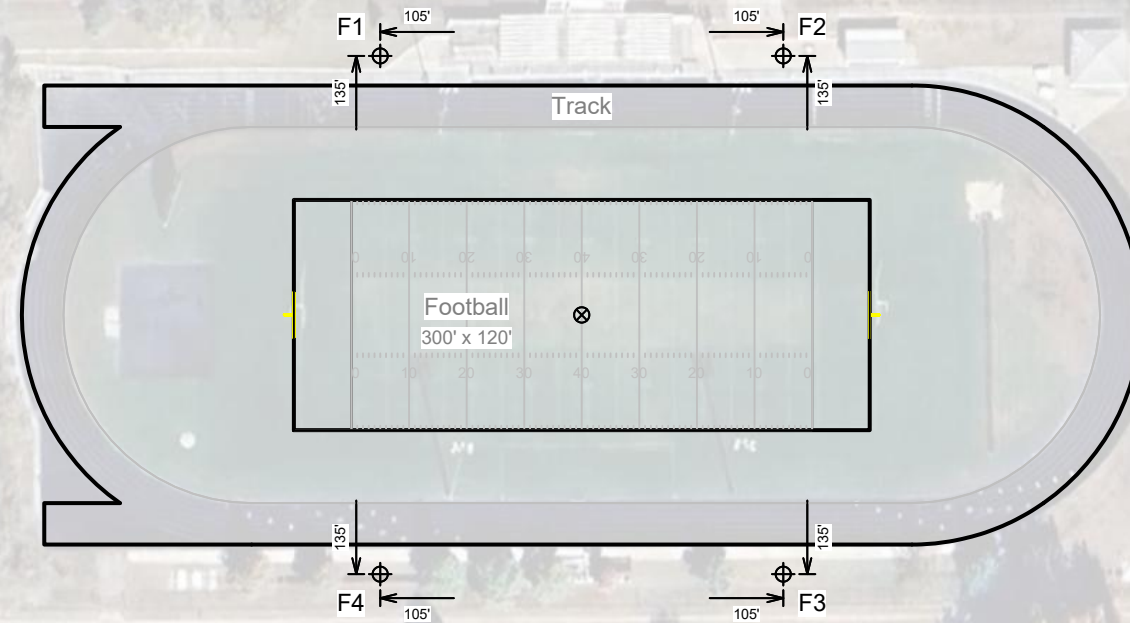

ENGINEERED DESIGN By: J. Adams III • File #214457A • 02-Apr-25

Pole location(s) ⊕ dimensions are relative to 0,0 reference point(s) ⊗



We Make It Happen.

Not to be reproduced in whole or part without the written consent of Musco Sports Lighting, LLC. ©1981, 2025 Musco Sports Lighting, LLC.

EQUIPMENT LAYOUT

PRELIMINARY FOUNDATION AND POLE ASSEMBLY DRAWING

TABLE 1: POLE ASSEMBLY

POLE ID	POLE HEIGHT ft (m)	# OF LUMINAIRES	ASSEMBLED POLE WEIGHT ³ lb (kg)
F1	70 (21.3)	9	2059 (934)
F2	70 (21.3)	9	2059 (934)
F3	70 (21.3)	8	1990 (903)
F4	70 (21.3)	8	1990 (903)

Pole Assembly Notes:

1. Steel pole should overlap concrete base and be seated tight with 1 1/2 ton come-alongs (contractor provided).
2. Align weldmarks on steel sections before assembling.
3. Assembled pole weight includes steel sections, crossarms, luminaires, and electrical components enclosures. If pole has stamped structural design then use pole weight (listed as vertical force) on stamped structural design document.
4. Section overlap must be pulled together until tight. Overlap measurement should be +/- 6 in (150 mm).
5. This document is not intended for use as an assembly instruction. See *Installation Instructions: Light-Structure System™ Lighting System* for complete assembly procedure.

TABLE 2: FOUNDATION DETAILS

POLE ID	CONCRETE BASE WEIGHT lb(kg)	BURIAL INFORMATION ^{3,4}		CONCRETE BACKFILL ^{1,2} yd ³ (m ³)	CUT BASE	LIGHTNING GROUND ⁵	
		G in (mm)	H ft (m)			TYPE	SUPPLEMENTAL INSTRUCTION
F1	2740 (1243)	30 (762)	12 (3.7)	1.5 (1.1)	NO	INTEGRATED ⁶	N/A
F2	2740 (1243)	30 (762)	12 (3.7)	1.5 (1.1)	NO	INTEGRATED ⁶	N/A
F3	2740 (1243)	30 (762)	12 (3.7)	1.5 (1.1)	NO	INTEGRATED ⁶	N/A
F4	2740 (1243)	30 (762)	12 (3.7)	1.5 (1.1)	NO	INTEGRATED ⁶	N/A

Foundation Notes:

1. Concrete backfill is calculated to 2 ft (0.6m) below grade (no overage included). Top 2 ft (0.6m) to be class 5 soil compacted to 95% density of surrounding undisturbed soil unless otherwise specified in stamped structural design.
2. Concrete backfill required 3000 lb/in² (20 MPa) minimum.
3. Foundation design per 2018 IBC, 115 mph, exposure category C, variation STD (Risk Category II).
4. Assumes IBC class 5 soils.
5. Standard bases include integrated lightning protection. If bases are cut, supplemental lightning protection is required. Contact Musco for materials and instruction.
6. Lightning protection is a manufacturer installed concrete encased electrode and connector. Ground connection is made when concrete base is installed and footing is poured. No additional steps required.

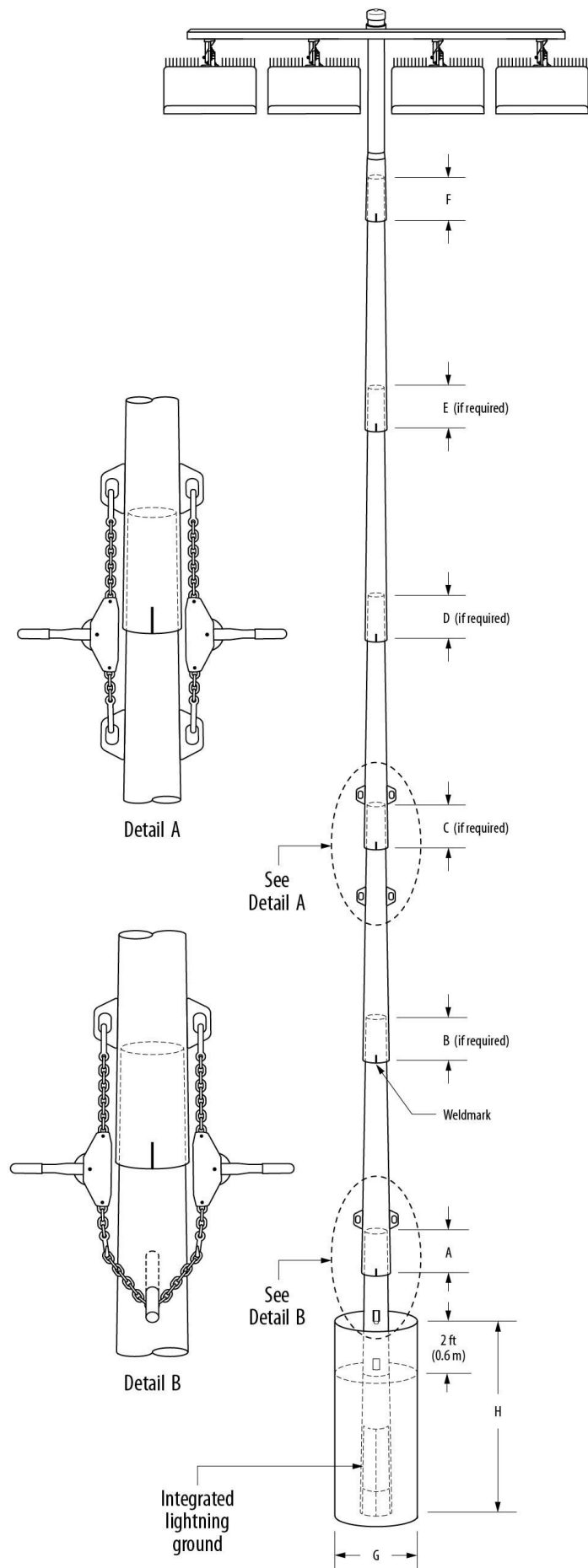

R60-62-00-en04-01_B

Ravenna High School Football - Ravenna, NE, USA

Date: 04/03/2025 Scale: Not to Scale

Representative: Brad Thompson Page: 1 of 1

Project: 214457 PRELIMINARY

Project		Catalog #		Type	
Prepared by		Notes		Date	



Ephesus

LUMASPORT 8 - Integral

CCT Tunable or Fixed-Color White LED Sports & Entertainment Luminaire

Typical Applications

Ball Fields • Pro Arenas • University & Collegiate Arenas
University & Collegiate Stadiums • Multi-Event & Convention Centers
Gymnasiums & Field Houses

Product Certification



Interactive Menu

- Ordering Information [page 3](#)
- Dimensional and Mounting Details [page 4](#)
- Performance Data [page 8](#)
- Electrical Performance Data [page 8](#)
- Ordering Information for Accessories [page 9](#)
- Accessory Dimensions and Part Details [page 10](#)
- Example System Topology [page 13](#)

Top Product Features

- Streamlined design ideal for one-to-one integral ballast retrofit systems speeding up and simplifying installation.
- Pre-aiming capability reduces installation time and ensures aiming precision.
- Industry leading light source reliability with Chip-on-Board LEDs with an efficacy up to 174 lumens per Watt.
- Award winning glare and cutoff control via patented Hybrid Reflector and TIR Optical System.
- Available in fixed CCT options of 4000K to 5700K and a tunable CCT range option of 3500K to 6500K to meet varying lighting demands.
- Top Mounted Yoke, Bottom Mounted Yoke, Pendant Mount and Slip Fitter Mounting options for flexibility in applications.
- Power redundancy insures system reliability.
- Wired DMX and Wireless AirMesh control protocols allow for system alerts, scheduling, and on-demand control of static and dynamic lighting scenes.
- Options to meet Trade Agreements Act requirements.

Lumasport 8 Tunable CCT Range

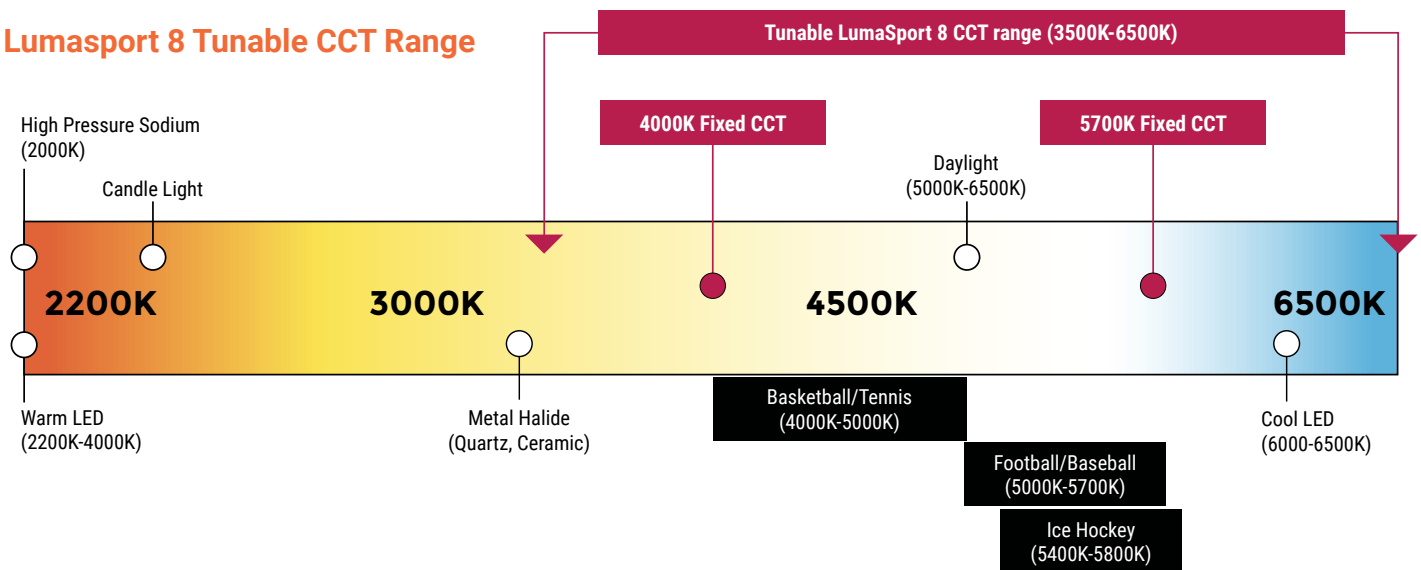

Mounting Configuration Examples



2QTY LUMASPORT 8 - INTEGRAL LUMINAIRE
SHOWN USING THE TOP MOUNT YOKE (TY)



2QTY LUMASPORT 8 - INTEGRAL LUMINAIRE
SHOWN USING THE BOTTOM MOUNT YOKE (BY)
ON A EPHEBUS CATWALK BRACKET (EPH-LS-CAT-N-2-U-B)



1QTY LUMASPORT 8 - INTEGRAL LUMINAIRE
SHOWN USING THE PENDANT MOUNT (RP)



1QTY LUMASPORT 8 - INTEGRAL LUMINAIRE
SHOWN USING SLIP FITTER MOUNTING BRACKET AND SLIP FITTER ACCESSORY (SLPFTR)
SLIP FITTER (SLPFTR) MOUNTING ACCESSORY SOLD SEPARATELY

Order Information

NOTE: A complete fixture order requires a selection entry for **Brand, Family, Model, Power Configuration, Color, CCT, CRI, Optic, Light Head Cable (DC), Voltage, Control, Mount Configuration, Power Cable (AC), Options, Packaging, & Special Option.**

SAMPLE ORDER NUMBER: EPH-LS-08-0680N-BLK-57-80-2S-C00-LV-AM-BY-A04-HEG-BP-ST

Brand	Family	Model	Power Configuration	Color	CCT	CRI	Optic	Light Head Interface (DC)
Brand ¹	Family	Model	Power Configuration	Color ²	CCT ³	CRI ⁴	Optic ^{5,6}	Light Head Interface (DC) ⁷
EPH = Ephesus, Standard TAA=Trade Agreements Act ¹	LS = Lumasport	08 = 8 Optics	0320N = 320W Integral Power 0530N = 530W Integral Power 0680N = 680W Integral Power	BLK = Black WHT = White	40 = 4000K 57 = 5700K PRO ³ = CCT Color Tuning	70 = 70 CRI 80 = 80 CRI 85 = 85 CRI	1S ⁵ = NEMA 3 17.5 33.3 2S = NEMA 3 21.9 40.2 3S = NEMA 3 25.4 45.7 4S = NEMA 4 36.0 64.4 5S = NEMA 5 46.6 82.6 7F = NEMA 7 72.5 131.0	C00 = Direct Connection
Notes: (1) Only product configurations with this designated prefix are built to be compliant with the Trade Agreements Act of 1979 (TAA). Please refer to DOMESTIC PREFERENCES website for more information. Components shipped separately may be separately analyzed under domestic preference requirements.				Notes: (2) Not coastal rated. Contact Ephesus for coastal fixture options.	Notes: (3) PRO only available with 530N	Notes: (4) 85 only available with PRO CCT	Notes: (5) Optic = NEMA TYPE; BEAM ANGLE; FIELD ANGLE. (6) Aiming angles for 680N power configuration and 1S optics between 30-90 Degrees.	Notes: (7) The driver assembly is integrated directly into the luminaire

Voltage	Control	Mount Configuration	Power Cable (AC)	Options	Packaging	Special Option
Voltage	Control ⁸	Mounting Configuration ^{9,10,11}	Power Cable (AC) ¹²	Options ^{13,14,15}	Packaging	Special Option
LV = Low Voltage HV = High Voltage	NC = No Control AM = Wireless AirMesh LB = Wired DMX	TY = Top Mounted Yoke BY = Bottom Mount Yoke, Catwalk Standard RP ¹⁰ = Pendant Mount SM ¹¹ = Slip Fitter mount	A00 = No Cable A04 = 4ft Cable, Standard A10 = 10ft Cable A20 = 20ft Cable BH3 = 3 Pin Connector on AC, 3ft Standard Cable	HEG = No Visor High Efficiency Glass Lens VHE ¹³ = Visor High Efficiency Glass Lens CV1 ¹⁴ = 1 Louver Cutoff Visor CV2 ¹⁴ = 2 Louver Cutoff Visor CV5 ¹⁴ = 5 Louver Cutoff Visor	BP = Bulk Pack	ST = Standard
	Notes: (8) PRO CCT not offered with NC = No Control	Notes: (9) Contact Ephesus for Slipfitter Mounting options. (10) RP = Pendant Mount not available in 0680N = 680N Integral Power configuration. (11) SM = Slip Fitter mount tilt range of 20-90 Slip Fitter mounting bracket is shipped separately from the light head. Slip Fitter (SLPFTR) Mounting Accessory Sold Separately.	Notes: (12) AC Cable connecting the luminaire to the electrical power source.	Notes: (13) VHE visor color only available in silver. (14) CV1, CV2, CV5 visor color only available in black. (15) CV1, CV2, CV5 will not be available on the PRO CCT		

DesignLights Consortium® Qualified. Refer to www.designlights.org Qualified Products List under Family Models for details

CCT PRO Tuning Operating Range

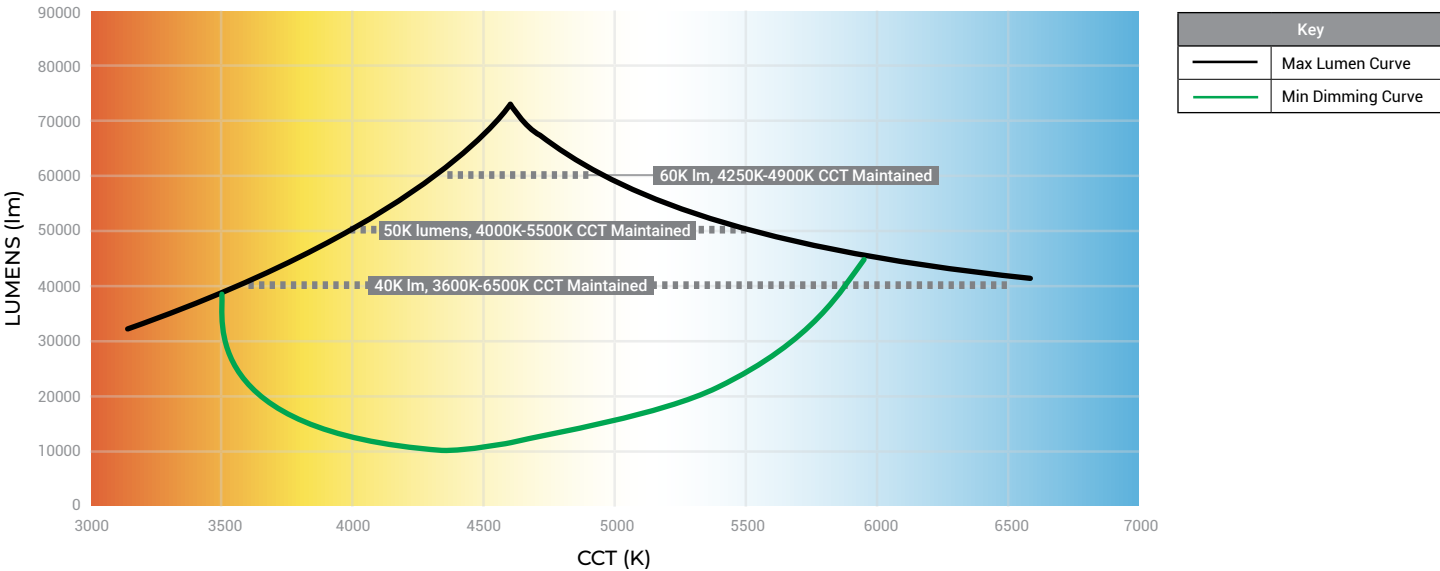

Dimensional and Mounting Details

MOUNTING CONFIGURATION: TOP MOUNT YOKE

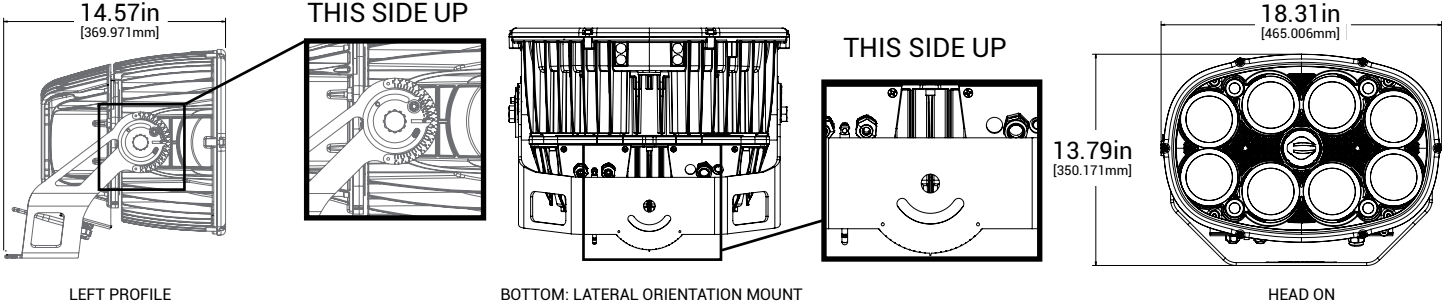

MOUNTING CONFIGURATION: BOTTOM MOUNT YOKE

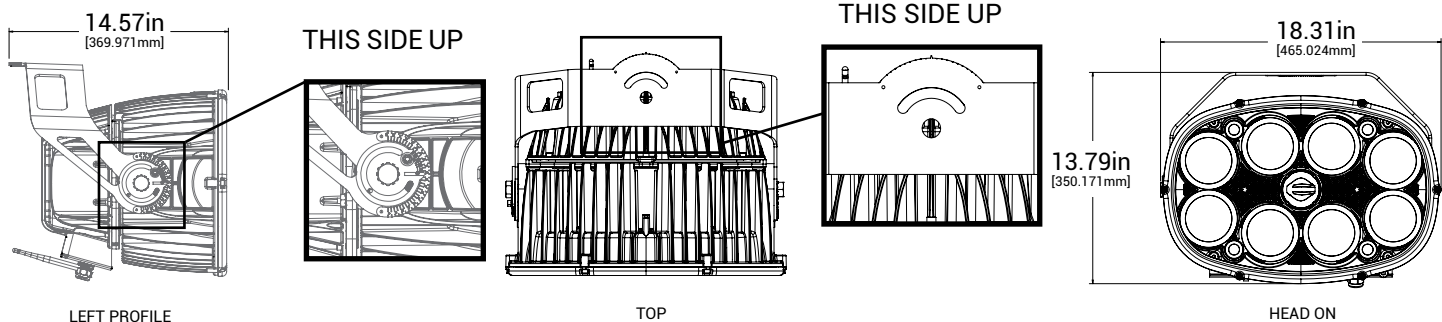

MOUNTING CONFIGURATION: PENDANT MOUNT

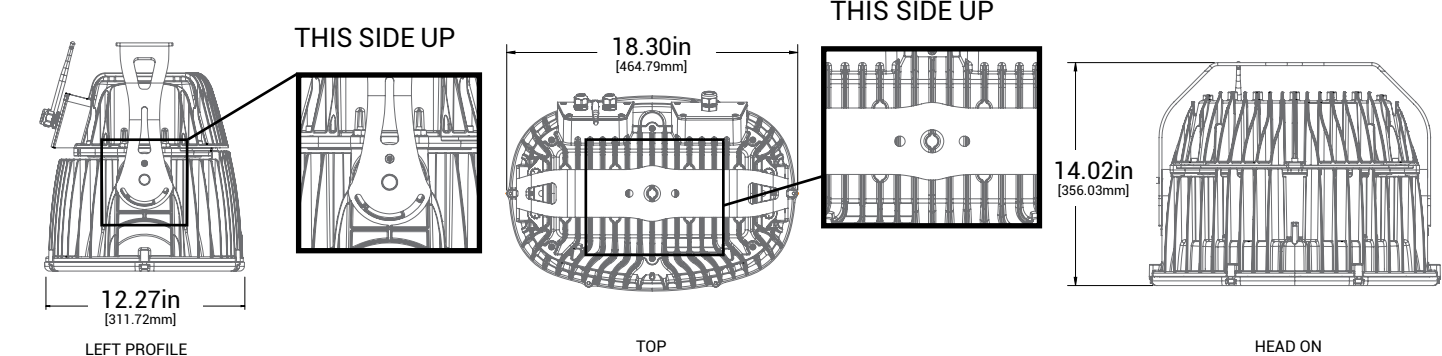

MOUNTING CONFIGURATION: SLIP FITTER MOUNT

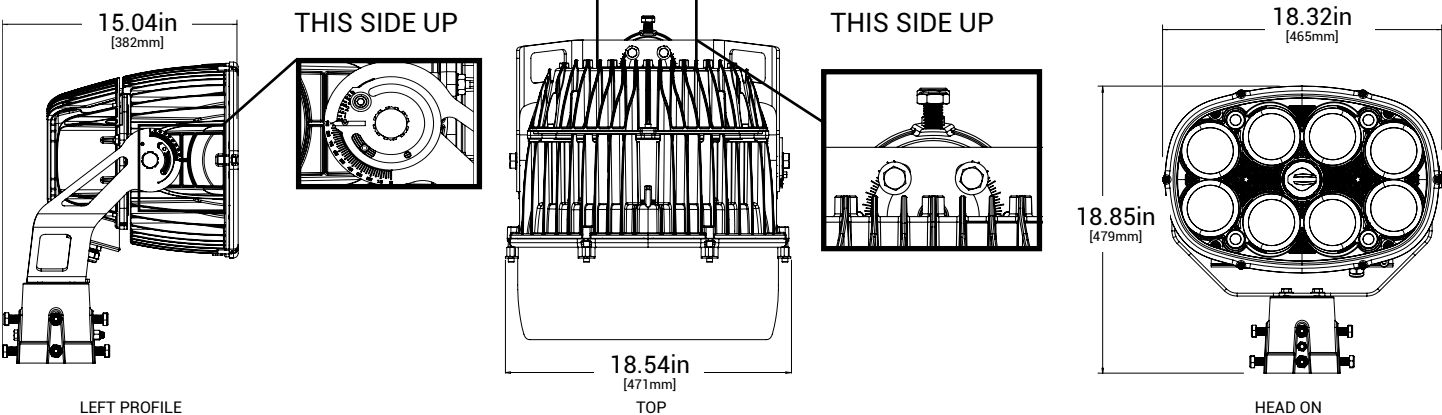

	320W		530W		680W	
Usage	Indoor	0-90 Degrees	Indoor	0-90 Degrees	N/A	N/A
	Outdoor	20-90 Degrees	Outdoor	20-90 Degrees	Outdoor	20-90 Degrees; 30-90 Degrees for 1S optic
Mounting options (1.5G Rated)	Top mount yoke, Bottom Mount Yoke, Pendant Mount, Slip Fitter Mount		Top mount yoke, Bottom Mount Yoke, Pendant Mount, Slip Fitter Mount		Top mount yoke, Bottom Mount Yoke, Slip Fitter Mount	

INCORRECT ORIENTATIONS

680W configurations can not be aimed downward below 20°
 680W 1S configurations can not be aimed downward below 30°
 All configurations can not be aimed downward below 20° outdoors or in wet locations

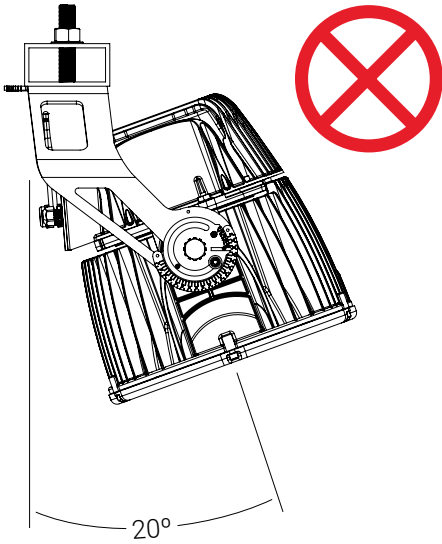

Uplight not allowed. Please contact Ephesus Sports Lighting for uplighting solutions.

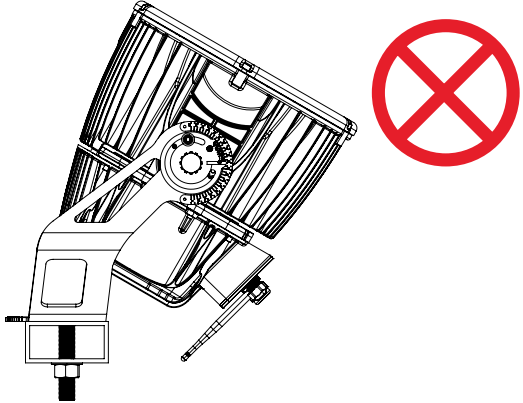

All configurations can not be inverted with junction box on top

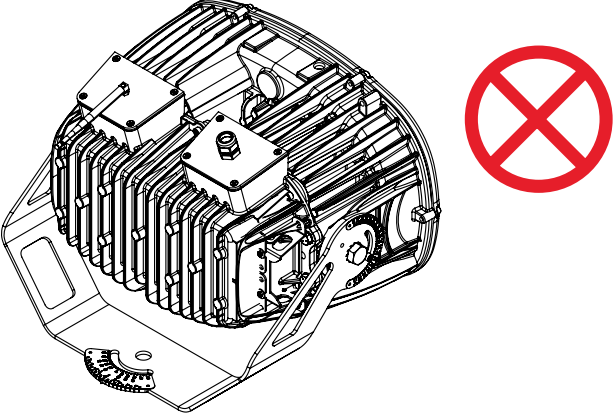

680W configurations can not be used with the Pendant Mount

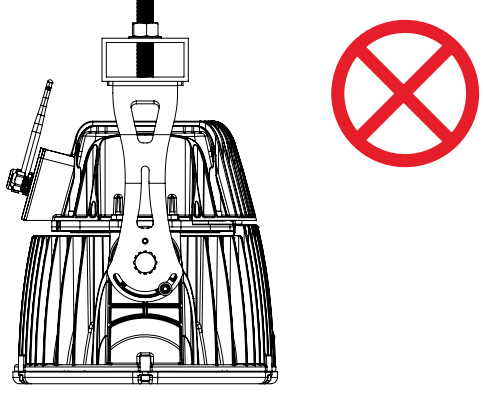

All configurations can not be side mounted

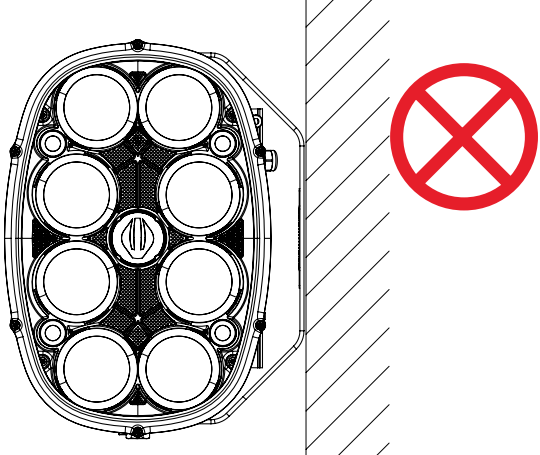

VHE Visor Option Dimensional Details

MOUNTING CONFIGURATION: BOTTOM MOUNT YOKE

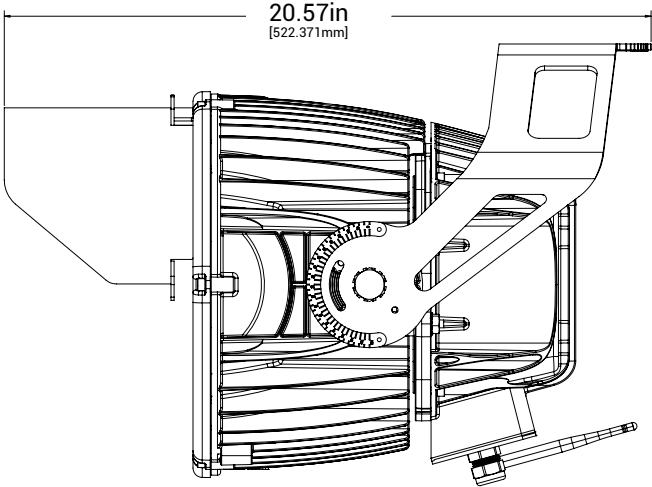

LEFT PROFILE: VISOR

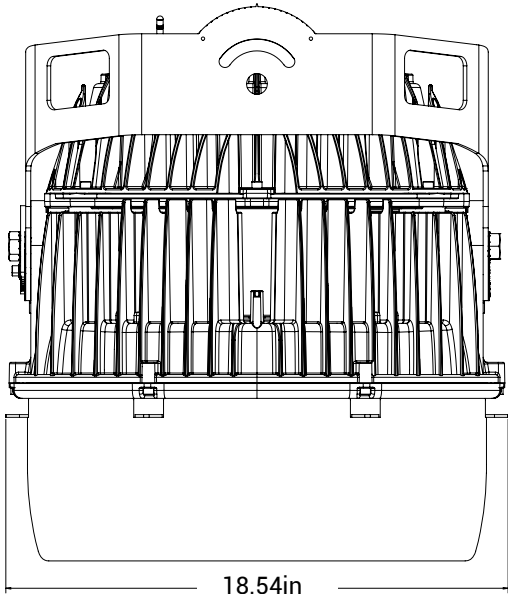

TOP: VISOR

NOTES:

The addition of a visor adds 4lbs of material to the luminaire weight.

MOUNTING CONFIGURATION: TOP MOUNT YOKE

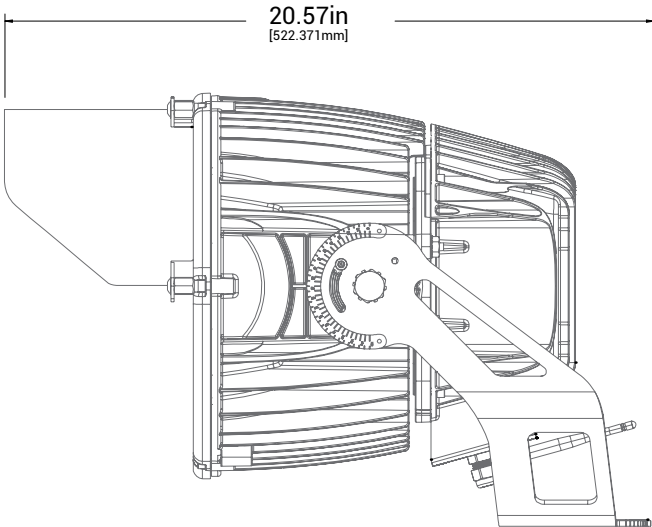

LEFT PROFILE: VISOR

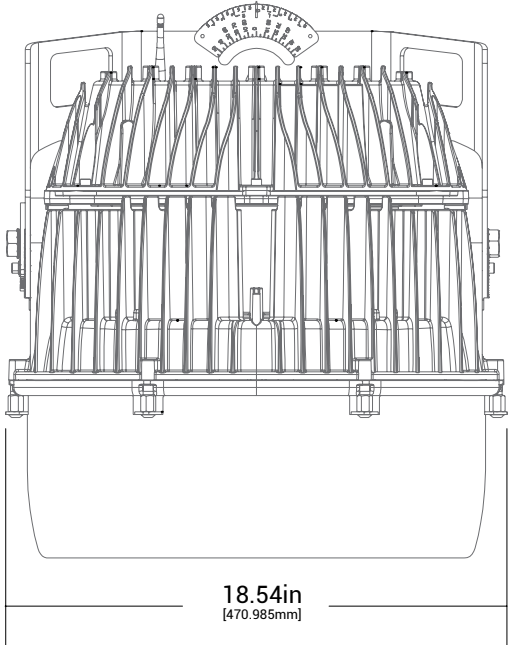

TOP: VISOR

CV1, CV2, CV5 Cutoff Visor Options*

*CV1, CV2, CV5 will not be available on the PRO CCT

CV1

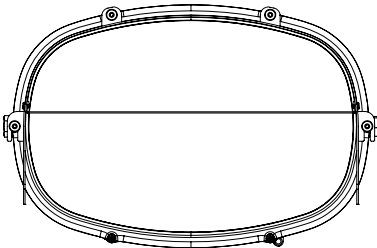

CV2

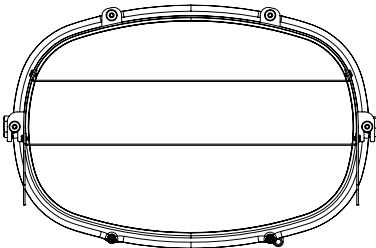

CV5

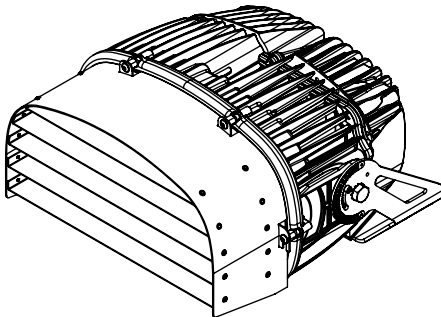
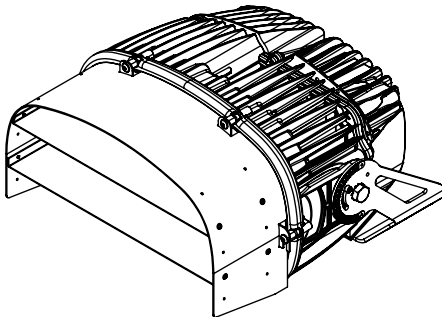
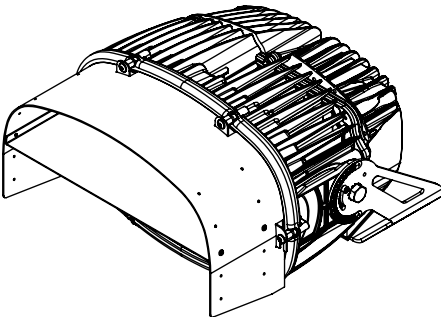
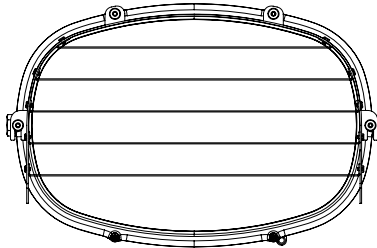

CV1, CV2, CV5 Cutoff Visor Option Dimensional Details

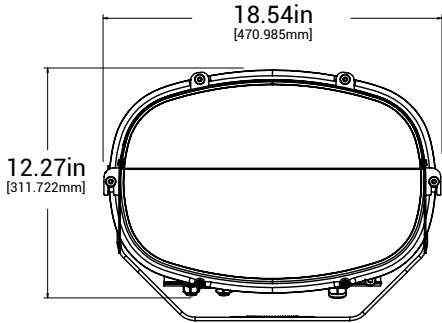
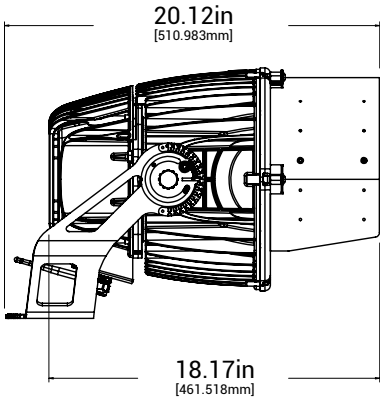
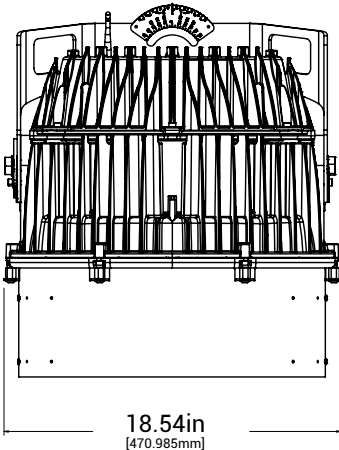

Performance Data¹

	LUMASPORT 8 (320W)	LUMASPORT 8 (530W)	LUMASPORT 8 (680W)
Lumen Output Range	51,000 - 60,000 lm	78,000 - 90,000 lm	93,000 - 111,000 lm
Lumen Output (PRO Version at 85CRI)¹⁰	N/A	56,596	N/A
Nominal Power²	355W	578W	724W
Input Voltage (Low Voltage)	120-277VAC	120-277VAC	120-277VAC
Input Voltage (High Voltage)	347-480VAC	347-480VAC	347-480VAC
Efficacy Range	149 - 174 lm/W	140 - 162 lm/W	128 - 159 lm/W
CRI³	70, 80	70, 80, 85 ¹¹	70, 80
TLCI⁴	up to 75	up to 75	up to 75
CCT Range	4000K, 5700K	4000K, 5700K	4000K, 5700K
CCT Tunable Range (PRO Version at 85CRI)	N/A	3500K - 6500K	N/A
Distribution (NEMA)	3-7	3-7	3-7
Dimming Range	DIM TO OFF, 10%-100%	DIM TO OFF, 10%-100%	DIM TO OFF, 10%-100%
Operating Temperature Range	-40°C to +40°C	-40°C to +40°C	-40°C to +40°C
Usage	INDOOR, OUTDOOR	INDOOR, OUTDOOR	OUTDOOR
Mounting Options (1.5G RATED)	TOP MOUNT YOKE, BOTTOM MOUNT YOKE, PENDANT MOUNT, SLIP FITTER MOUNT	TOP MOUNT YOKE, BOTTOM MOUNT YOKE, PENDANT MOUNT, SLIP FITTER MOUNT	TOP MOUNT YOKE, BOTTOM MOUNT YOKE, SLIP FITTER MOUNT
Electrical Certifications	FCC, UL8750, UL1598, DLC Standard (NANQSV)	FCC, UL8750, UL1598, DLC Standard (NANQSV)	FCC, UL8750, UL1598, DLC Standard (NANQSV)
Environmental Certifications	IP66	IP66	IP66
Vibration	ANSI C136.31-2010 1.5G	ANSI C136.31-2010 1.5G	ANSI C136.31-2010 1.5G
Surge	10kV	10kV	10kV
Effective Projected Area (EPA)	1.93 (sq. ft.)	1.93 (sq. ft.)	1.93 (sq. ft.)
Effective Projected Area (EPA) with Visor (VHE, CV1, CV2, CV5)⁸	2.2 - 2.4 (sq. ft.)	2.2 - 2.4 (sq. ft.)	2.2 - 2.4 (sq. ft.)
Approximate Weight⁹	57 LBS	57 LBS	57 LBS
Approximate Weight with Visor (VHE, CV1, CV2, CV5)⁹	61 LBS	61 LBS	61 LBS

NOTES:

- (1) Specifications are subject to change without notice.
- (2) Values are +/- 4% when fixture is operated at 25°C ambient
- (3) Values are +/- 2%
- (4) Values are +/- 3 points.
- (5) When driver box is mounted in upright position.
- (6) Luminaire meets NEMA4X Certification
- (7) LumaSport 8 with Visors (VHE, CV1, CV2, CV5) qualifies for ANSI C136, 31-2010 1.5G
- (8) EPA may vary depending on the aiming angle of the fixture.
- (9) Weight may vary depending on mounting bracket, VHE Visor option, and luminaire configuration.
- (10) Based of 3S Optic, 85 CRI, 5000 CCT
- (11) 85 CRI is only available in PRO model

Electrical Performance Data

Product	Voltage level	Input voltage range (Vac)	Nominal input power(W)	Input Current(A)	Power factor (@ max load)	THDi(@ max load)%	Inrush period (ms)	Peak Inrush (A)
EPH-LS-08-0320N-XXX-LV	(-LV-) Low voltage	120	357	2.97	0.99	4.79	0.28	133
		277	349	1.28	0.98	7.66	0.27	311
EPH-LS-08-0320N-XXX-HV	(-HV-) High voltage	347	359	1.04	0.99	7.02	0.41	92
		480	358	0.76	0.98	9.20	0.41	129
EPH-LS-08-0530N-XXX-LV	(-LV-) Low voltage	120	591	6.81	0.99	5.61	0.40	188
		277	573	2.84	0.97	11.60	0.38	440
EPH-LS-08-0530N-XXX-HV	(-HV-) High voltage	347	576	2.40	0.99	8.16	0.58	130
		480	573	1.69	0.98	10.17	0.58	182
EPH-LS-08-0530N-XXX-PRO-85-LV	(-LV-) Low voltage	120	598	4.99	0.99	4.70	0.40	188
		277	586	2.12	0.97	7.70	0.38	440
EPH-LS-08-0530N-XXX-PRO-85-HV	(-HV-) High voltage	347	594	1.71	0.99	8.10	0.58	130
		480	588	1.23	0.97	10.50	0.58	182
EPH-LS-08-0680N-XXX-LV	(-LV-) Low voltage	120	744	8.50	0.99	5.69	0.40	188
		277	716	3.50	0.98	11.32	0.38	440
EPH-LS-08-0680N-XXX-HV	(-HV-) High voltage	347	722	2.99	0.99	6.86	0.58	130
		480	716	2.11	0.98	9.16	0.58	182

NOTE: All values measured at 25°C ambient conditions

Ordering Information for Accessories

NOTE: A complete accessory order requires a selection entry for **Brand, Accessory, Option**.

SAMPLE ORDER NUMBER: **EPH-HRDM34-025**

Brand	Accessory	Option	Intended Use
EPH = Ephesus	EXTPLT = Extension Plate ¹	025 = .25in 050 = .5in 200 = 2.0in	Extension Plate Kit to mount to structures .25in, .5in, or 2.00in thick. Designed to be used with the LUMASPORT 8 - Local, LUMASPORT 8 - Integral, LUMADAPT 8, LUMASPORT 8 PRISM - Local luminaires only.
	DVGBRD = Diving Board ²		Diving Board to mount to 2in x 4in steel cross arms. Designed to be used with the LUMASPORT 16 - Local, LUMASPORT 8 - Local, LUMASPORT 8 - Integral, LUMADAPT 8, LUMASPORT 8 PRISM - Local luminaires only.
	HRDM58 = Mounting Hardware 5/8in diameter	050 = .375in - .50in Range of Clamping Thickness ³ 200 = 2in Clamping Thickness ³	HRDM58-050: .375-.50in clamping thickness, Use for Extension Plate (EXTPLT) or other flat surfaces drilled for 5/8in hardware HRDM58-200: 2.00in clamping thickness, use for 2in x 4in Cross arms that are drilled for 5/8in hardware
	HRDM34 = Mounting Hardware 3/4in diameter	025 = .25in ⁴ 075 = .75in ⁴ 200 = 2in ⁴	HRDM34-025: .25-.50in clamping thickness, use for diving board (DVGBRD) or other flat surfaces drilled for 3/4in hardware HRDM34-075: .50-.75in clamping thickness, flat surfaces drilled for 3/4in hardware HRDM34-200: 2.00in clamping thickness, use for 2in x 4in Cross arms that are drilled for 3/4in hardware
	Notes: (1) Additional mounting fastener hardware kit needed to attach a fixture to the EXTPLT = Extension Plate (2) Additional mounting fastener hardware kit needed to attach a fixture to the DVGBRD = Diving Board	Notes: (3) Option only available for use with HRDM58 (4) Option only available for use with HRDM34	

Extension Plate (EXTPLT) Dimension and Part Details:

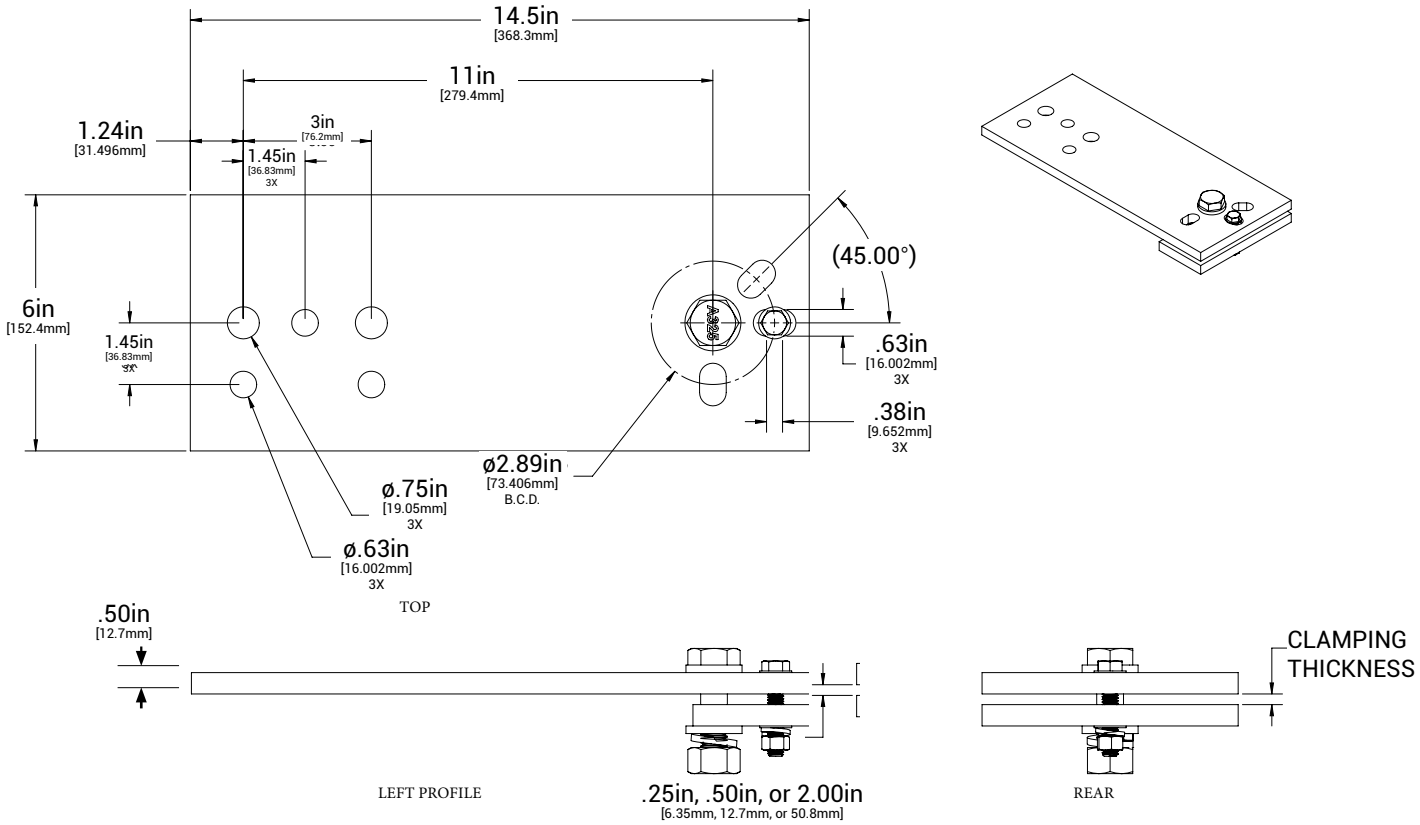

Extension Plate Data

MODEL #	WEIGHT (LBS)
EXTPLT	14.63
EXTPLT + HRDM58-050	15.28

Extension Plate Kit Parts

DESCRIPTION	QUANTITY
Extension Plate	1
Washer Plate	1
5/8in Hex Bolt	1
5/8in Washer	2
5/8in-11 Hex Nut	1
5/8in Split Washer	1
3/8in Washer	2
3/8in Hex Bolt	1
3/8in Split Washer	1
3/8in-16 Hex Nut	1

Diving Board (DVGBRD) Dimension and Part Details:

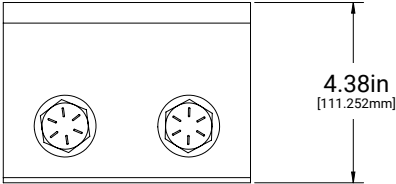
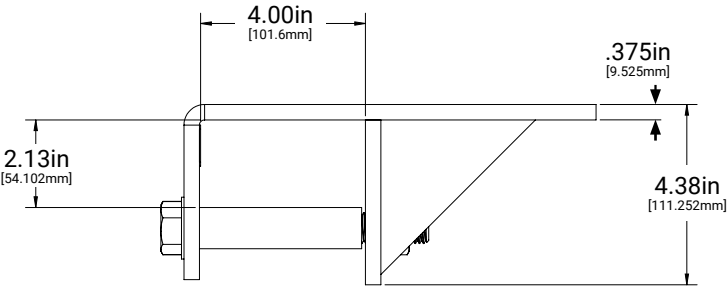
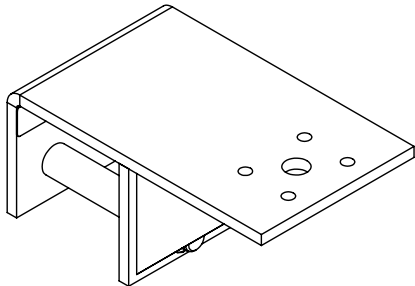
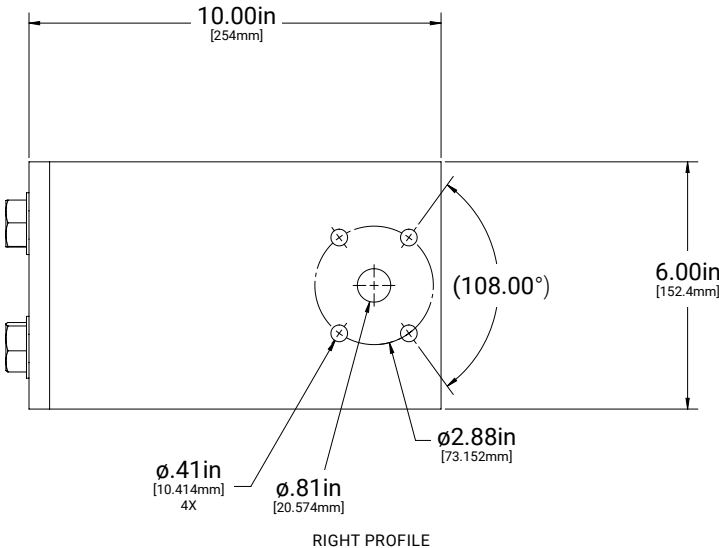

Diving Board Data

MODEL #	WEIGHT (LBS)
DVGBRD	15.1
DVGBRD + HRDM34-025	16.1

Diving Board Parts

DESCRIPTION	QUANTITY
Welded Bracket	1
Bolt Sleeve	2
3/4in-10 X 6in Structural Hex Bolt, Hot Dip Galvanized	2
3/4in Steel Flat Washer, Hot Dip Galvanized	2
3/4in Ext Tooth Washer, Steel, Magni-565 Grey Polycoat	2
3/4in-10 Structural Steel Hex Nut, Hot Dip Galvanized	2
Stainless Shim	1

HRDM58 Dimension and Part Details:

HRDM58-050:
 .375-.500in clamping thickness, Use for Extension Plate (EXTPLT) or other flat surfaces drilled for 5/8in hardware

HRDM58-200:
 2.00in clamping thickness, use for 2in x 4in Cross arms that are drilled for 5/8in hardware

HRDM58 Data

MODEL #	WEIGHT (LBS)
HRDM58-050	.65
HRDM58-200	.84

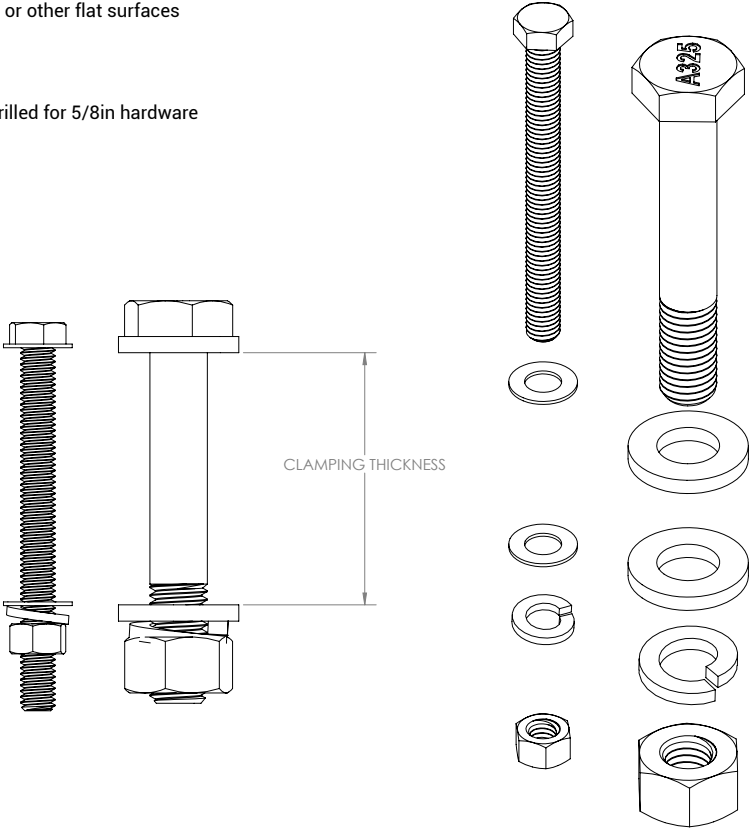

HRDM34 Dimension and Part Details:

HRDM34-025:
 .25-.50in clamping thickness, use for diving board (DVGBRD) or other flat surfaces drilled for 3/4in hardware

HRDM34-075:
 .50-.75in clamping thickness, flat surfaces drilled for 3/4in hardware

HRDM34-200:
 2.00in clamping thickness, use for 2in x 4in Cross arms that are drilled for 3/4in hardware

HRDM34 Data

MODEL #	WEIGHT (LBS)
HRDM34-025	1
HRDM34-075	1.5
HRDM34-200	2

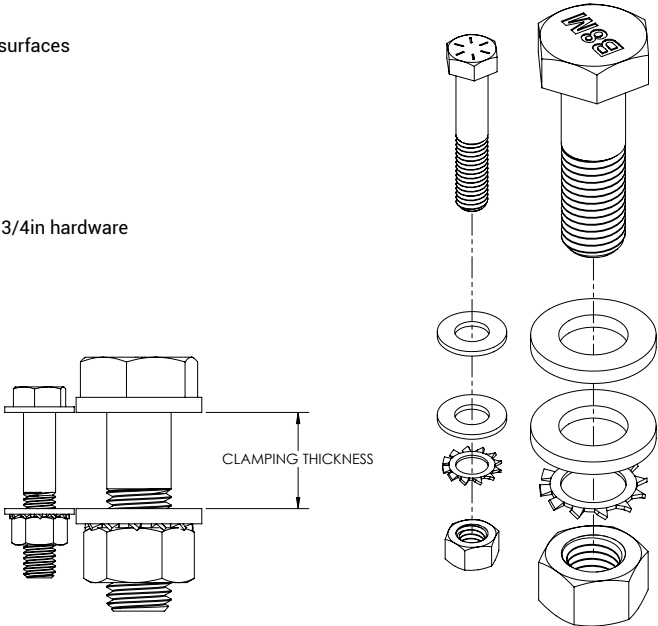

Example System Topology (Wireless AirMesh Controls)

Example system topology showing the LUMASPORT 8 Integral System in a Wireless AirMesh Control Installation. Note: Laptop and mobile device not included. A cellular network connection requires a cellular carrier network plan.

REMOTE ACCESS

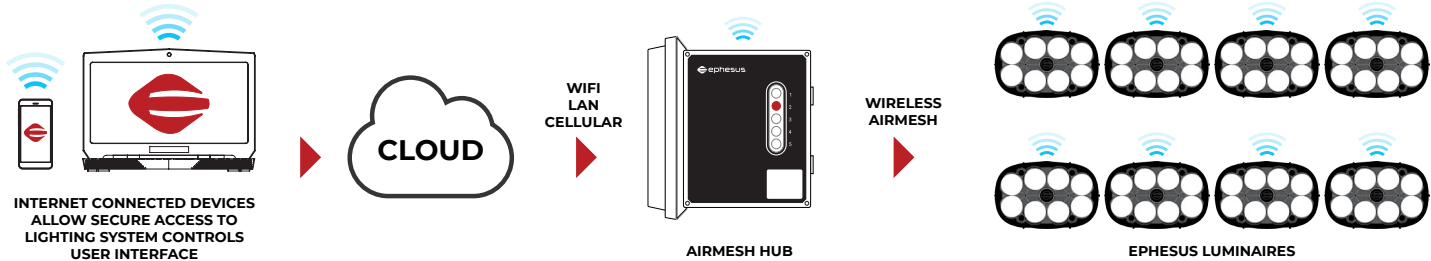

ON SITE ACCESS

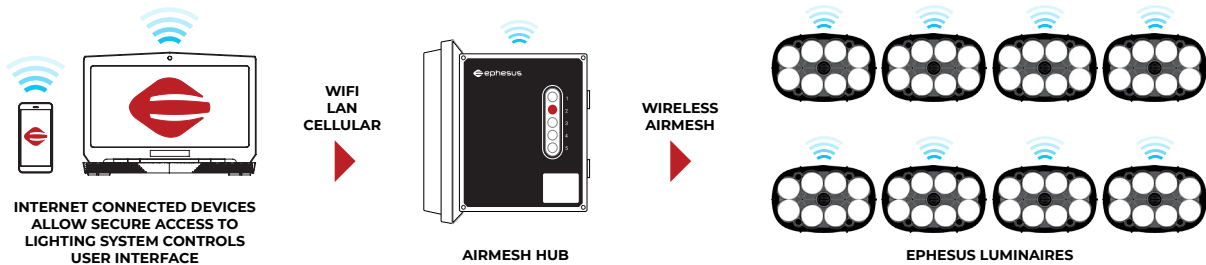

Example System Topology (Wired DMX Controls)

Example system topology showing the LUMASPORT 8 Integral System in a commonly used wired DMX Control Installation. Refer to the specifications and limitations of your wired DMX control device before installing this configuration.

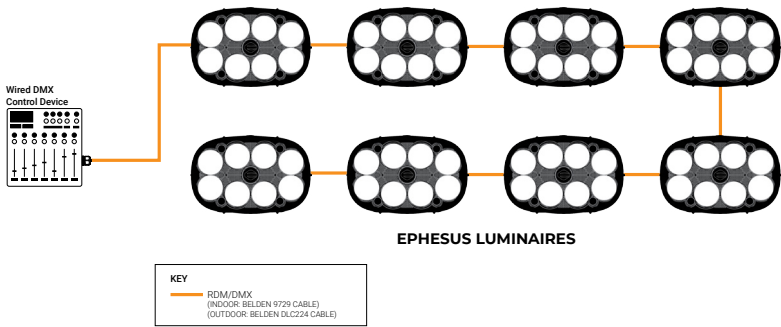

Luminaire Schedule					
Symbol	Qty	Label	Arrangement	Total Lamp Lumens	LLF
⊕	32	HL-APS-750WD-50K-N4, PC Lens,	SINGLE	113880	0.950

Calculation Summary							
Label	CalcType	Units	Avg	Max	Min	Avg/Min	Max/Min
Football Field	Illuminance	Fc	38.53	57	28	1.38	2.04



HL-APS-750WD-50K



Luminaire Location Summary						
LumNo	Label	Orient	Tilt	X	Y	Z
1	HL-APS-750WD-50K-N4, PC Lens,	316.931	68.281	257	296	50
2	HL-APS-750WD-50K-N4, PC Lens,	247.38	61.103	257	296	50
3	HL-APS-750WD-50K-N4, PC Lens,	257.521	68.125	257	296	50
4	HL-APS-750WD-50K-N4, PC Lens,	270.458	68.134	257	296	50
5	HL-APS-750WD-50K-N4, PC Lens,	283.808	67.565	257	296	50
6	HL-APS-750WD-50K-N4, PC Lens,	296.761	69.054	257	296	50
7	HL-APS-750WD-50K-N4, PC Lens,	308.598	71.029	257	296	50
8	HL-APS-750WD-50K-N4, PC Lens,	262.983	69.046	257	296	50
9	HL-APS-750WD-50K-N4, PC Lens,	225.682	67.104	461	299	50
10	HL-APS-750WD-50K-N4, PC Lens,	234.273	70.348	461	299	50
11	HL-APS-750WD-50K-N4, PC Lens,	246.801	69.905	461	299	50
12	HL-APS-750WD-50K-N4, PC Lens,	296.301	62.642	461	299	50
13	HL-APS-750WD-50K-N4, PC Lens,	285.101	68.976	461	299	50
14	HL-APS-750WD-50K-N4, PC Lens,	220.98	69.069	461	299	50
15	HL-APS-750WD-50K-N4, PC Lens,	272.603	65.497	461	299	50
16	HL-APS-750WD-50K-N4, PC Lens,	258.038	67.415	461	299	50

Luminaire Location Summary						
LumNo	Label	Orient	Tilt	X	Y	Z
17	HL-APS-750WD-50K-N4, PC Lens,	141.882	58.691	291	73	50
18	HL-APS-750WD-50K-N4, PC Lens,	127.569	62.968	291	73	50
19	HL-APS-750WD-50K-N4, PC Lens,	110.344	62.119	291	73	50
20	HL-APS-750WD-50K-N4, PC Lens,	35.776	59.057	291	73	50
21	HL-APS-750WD-50K-N4, PC Lens,	47.802	63.623	291	73	50
22	HL-APS-750WD-50K-N4, PC Lens,	67.681	63.948	291	73	50
23	HL-APS-750WD-50K-N4, PC Lens,	81.439	61.898	291	73	50
24	HL-APS-750WD-50K-N4, PC Lens,	133.472	64.682	291	73	50
25	HL-APS-750WD-50K-N4, PC Lens,	35.87	57.93	439	72	50
26	HL-APS-750WD-50K-N4, PC Lens,	61.821	68.456	439	72	50
27	HL-APS-750WD-50K-N4, PC Lens,	145.528	58.269	439	72	50
28	HL-APS-750WD-50K-N4, PC Lens,	129.369	63.545	439	72	50
29	HL-APS-750WD-50K-N4, PC Lens,	113.199	61.207	439	72	50
30	HL-APS-750WD-50K-N4, PC Lens,	90	58.498	439	72	50
31	HL-APS-750WD-50K-N4, PC Lens,	69.905	60.086	439	72	50
32	HL-APS-750WD-50K-N4, PC Lens,	48.764	65.015	439	72	50



Ravenna FB

AEON™ PNR SERIES

What makes the AEON™ LED Sports Light your Lighting Solution of Choice?

Fully Encased Luminaire Protects Sensitive Electronic Components against any Outside Elements

Neutral Color reflects all Wavelengths of External Light

AEON Luminaire Specific Designed Proprietary LED Drivers



Proprietary Glare-Free Illumination: UGR <19 with Controlled Intensity and Uniformity

- Available in NEMA: 3, 4, & 6 Beam Spreads
- High Color Rendition: CRI >85+
- Up to 170+ Delivered LpW
- Designed for 4K / HDTV Broadcasting

Neighborhood-Friendly No Light Spillage or Sky Glow



NEXGEN PRODUCTS

Corrosion Resistant Stainless Steel Hardware

Comes Standard with Prewired Double-Sheathed Quick-Connect Cord

Standard Included: Instant On/Off and Continuous Dimming

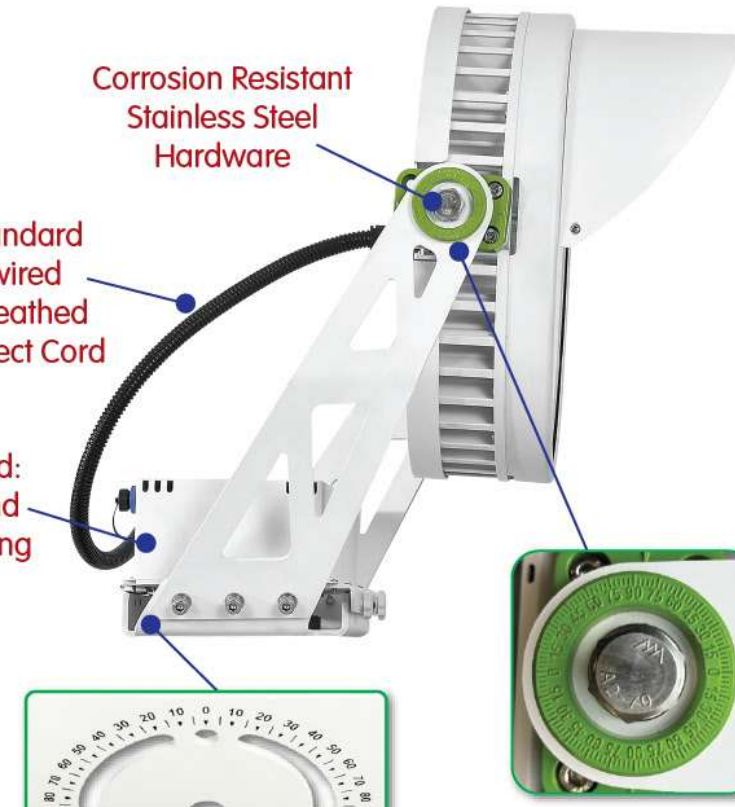

Meets/Exceeds National & International Standards



Patented Cross-Vent Convection Design

Easy Quick Connect Wiring System for Controls

Multi-Voltage Options
100-277VAC / 347-480VAC

Comes Standard with 3.3 ft (1m) Stainless Steel Safety Cable

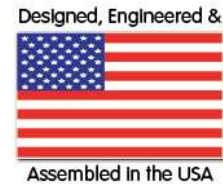

Outstanding Features:

- Incredibly High (95%+) Total Efficiency and with the Highest Efficacy in its own Class: Up to 170+ Delivered LpW. Greater Light, Fewer Luminaires.
- Heavy-Duty, Lightweight and Durable Die-Cast Design for High Wear Resistance: Withstands Harsh, Extreme Outdoor Conditions and Corrosive Environments.
- Fully Encased Luminaire with Patented Cross-Vent Convection Design: Protects Sensitive LED Package and Electronic Components against any Outside Elements.
- Rugged, Weather-Tight Design, IP67 Rated for Wet Location.
- Incredibly Long-Life Span of over 100,000 Hours.
- Operational Flexibility: Adaptable to Various Intelligent Lighting Controls - Wired or Wireless.
- Solid-State Design: No Moving Parts. Ideal for High Vibration Areas (ANSI C136.31, 3G Rated). Simple, Reliable, and Affordable, Maintenance-Free Design.
- High Color Rendition showing True Colors: CRI >85.
- Advanced Functionality and User Friendly with Quick Connect System.
- User Friendly Features: Lenses, Modules and Drivers are Field-Changeable. Saves Time, Labor and Money for a Quick and Easy Installation Process

HYLITE™
LED Lighting

NEXGEN
PRODUCTS

Available in Two Popular Lumen Packages with Various NEMA Beam Spreads to suit a Variety of Sports Lighting Applications

- 170+ LpW
- IP67
- Glare-Free, UGR <19

AEON™
PNR SERIES

With Enhanced Glare-Free Illumination, the AEON PNR Series Sports Light Provides Crisp Illumination, avoiding any Visual Discomfort. AEON's Proprietary Optics produce the Ideal Light Distribution for Variety of Sports Lighting applications, while saving you up to 75% in Energy use compared to Traditional HID Lighting.

Engineered with State-of-the-Art technology for Efficiency, Glare Control, and Uniformity, the AEON PNR Series Sports Light features Instant On/Off, Dimming, Full Controllability, High Energy Efficiency and Flicker-Free Lighting.

The AEON AEON PNR Series Sports Light delivers Simple, Smart and Easy-to-use Sports Lighting Solutions that provide Advanced Functionality, Versatility and Operational Efficiency.

2 Popular Lumen Packages to Suit a Variety of Indoor and Outdoor Applications:

500W: 91,300 Lumens

750W: 113,880 Lumens



SAVE UP TO
75%
ON YOUR
ENERGY COSTS



Illuminating facts about High Performance AEON™ LED PNR Series Sports Light - Better for your Eyes, Better for the Planet.

What makes the AEON™ LED Sports Light your Lighting Solution of Choice?

The Ultimate Sports Light for Versatility

- The Most Powerful Sports Light Luminaire with Highest Reliability Level: Incredibly High 95% Total Efficiency and with Highest Efficacy in its own Class: Up to 170 Delivered LpW. More Light with Fewer Luminaires.
- Heavy-Duty, Lightweight and Durable Die-Cast Design for High Wear Resistance: Withstands Harsh, Extreme Outdoor Conditions and Corrosive Environments.
- Proprietary Thermal Efficient Design with Passive Cooling Maximizes Heat Dissipation for Longer Life of the Luminaire. Designed for Greater Life Expectancy in Warmer Climates.
- Patented Revolutionary Aerodynamic Design for Minimal Wind Resistance.
- State-of-the-Art, Aesthetically Pleasant Compact Design with No Exposed Electronics or Wiring. Rugged, Weather-tight Design, IP67 (NEMA 4X) Rated for Wet location.
- Available with Optional Tempered Glass Lens for additional Safety and UV Protection.
- Patented Cross-Vent Convection Design for Longer Life of LED Package and Electronic Components.
- Adjustable in 7.5° Increments: 0-90° Orient and 270° Tilt Angle.
- Proprietary Glare-Free Illumination: No Uncomfortable Sensation. UGR <19.
- Precise, Custom-engineered Optics with Controlled Intensity and Uniformity: Maintains Consistent Delivered Foot Candles over Luminaire's Life.
- High Color Rendition showing True Colors: CRI >85+.
- Proprietary Design offers Uniform and Constant Light Levels throughout the Life of the Luminaire with Minimal Lumen Depreciation.
- Avoids Light Pollution and Trespass: Optical Accuracy. Directs Light precisely where needed without Spill.
- Advance Technology for Luminaire Longevity: Integrated Power Supply Operates at Lower Temperature and at incredible 95% Efficiency.
- Technology within the Luminaire: No Outside Exposure to any Sensitive Electronic Components.
- Ultra-Low EMI eliminates Electrical Interference with surrounding Electronic Systems.



98%
RECYCLABLE
NO
LEAD, MERCURY, TOXIC
GASES OR HEAVY METALS



Additional Options available:

- Full RGB Colors and DMX Controls
- Extended Warranty
- Complete Package with Poles, Cross-Arms & Platforms

Designed, Engineered &



Assembled in the USA

AEON Model	Watts	Delivered Lumens	HID Equivalent	Energy Savings*	Current Draw (mA)						Net Weight	EPA (Sq. Ft.)
					120V	208V	240V	277V	347V	480V		
HL-APS-500WD	500W	91,300	2000W	75%	4386	2530	2193	2006	1601	1157	43 lbs. (19.5 Kg.)	2.25
HL-APS-500WD-TG											48 lbs. (22 Kg.)	
HL-APS-750WD	750W	113,880	3000W	75%	6579	3796	3289	3008	2402	1736	46 lbs. (21 Kg.)	2.25
HL-APS-750WD-TG											52 lbs. (23.4 Kg.)	

TG = With Tempered Glass Lens

* Does not include Ballast Loss, Maintenance, Replacement Lamp Savings and Disposal Costs which amount to an additional Savings of 30~50%!

2 Popular Lumen Packages to Suit a Variety of Indoor and Outdoor Applications

NEXGEN PRODUCTS

2-for-1 Replacement. More Light Less Luminaires

AEON™ Proprietary Glare-Free LED Optics

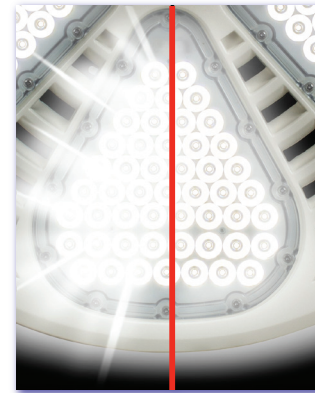

Standard LED Optics

- Rugged, Durable and Compact Luminaire stands up to the most demanding Elements and is Excellent for use in Hot & Humid Climates and Suitable for use in Corrosive Environments.
- UV Stabilized Electrostatic Finish and Stainless Steel Hardware to withstand Extreme Outdoor Conditions.
- Neighborhood-Friendly: No Spillage or Sky Glow.
- Incredibly Long-Life Span of over 100,000 Hours.
- Save Labor Cost Significantly: Quick & Easy Installation Process.
- Simple, Reliable, and Affordable, Maintenance-free Design.
- Advanced Functionality and User Friendly with Quick Connect System.
- Solid-State: No Moving Parts. Ideal for High Vibration Areas (ANSI C136.31, 3G Rated).
- Standard Included: Instant On/Off, Continuous Dimming, Prewired Sheathed Cord, and 3.3 ft. (1M) Stainless Steel Safety Cable.
- Multi-Voltage: Available in 120-277VAC and 347-480VAC.
- 6kV (Line-Line) and 10kA/20kV (Line-Ground) Surge Protection against Over Voltage, Short Circuit, and Over Temperature.
- Suitable for Ambient Temperatures: -40°F~+122°F (-40°C~+50°C).
- RoHS Compliant: No Lead, Mercury, Toxic Gases or any Hazardous Materials. Facilitates LEED® points.
- Environmentally Friendly: 98% Recyclable.
- Low Total Cost of Ownership. Shortest Payback Period and a High ROI.
- Meets/Exceeds National and International Standards



Multi-Voltage Options

120-277VAC / 347-480VAC

SAVE UP TO **75%** ON YOUR ENERGY COSTS

Shown with Optional Tempered Glass Lens



98% RECYCLABLE



NO LEAD, MERCURY, TOXIC GASES OR HEAVY METALS

As part of the company's continuous product improvement program, HyLite reserves the right to change materials or modify the design of its product without notification. All Specifications subject to change without notice. All values are design and/or typical values when measured under laboratory conditions. Actual Values depend upon the ambient temperature of the installation location. Please consult factory for your specific requirements.

APS-500 and APS-750W Dimensions with Polycarbonate Lens

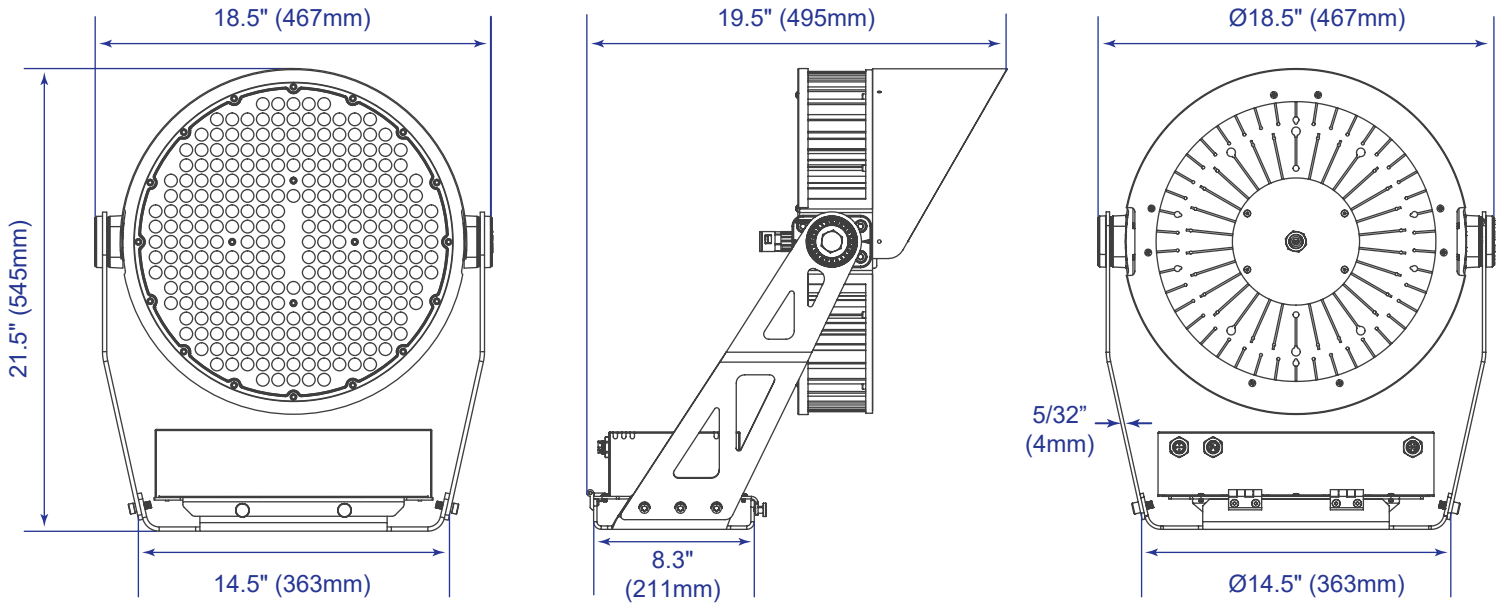

APS-500 and APS-750W Dimensions with Tempered Glass Lens

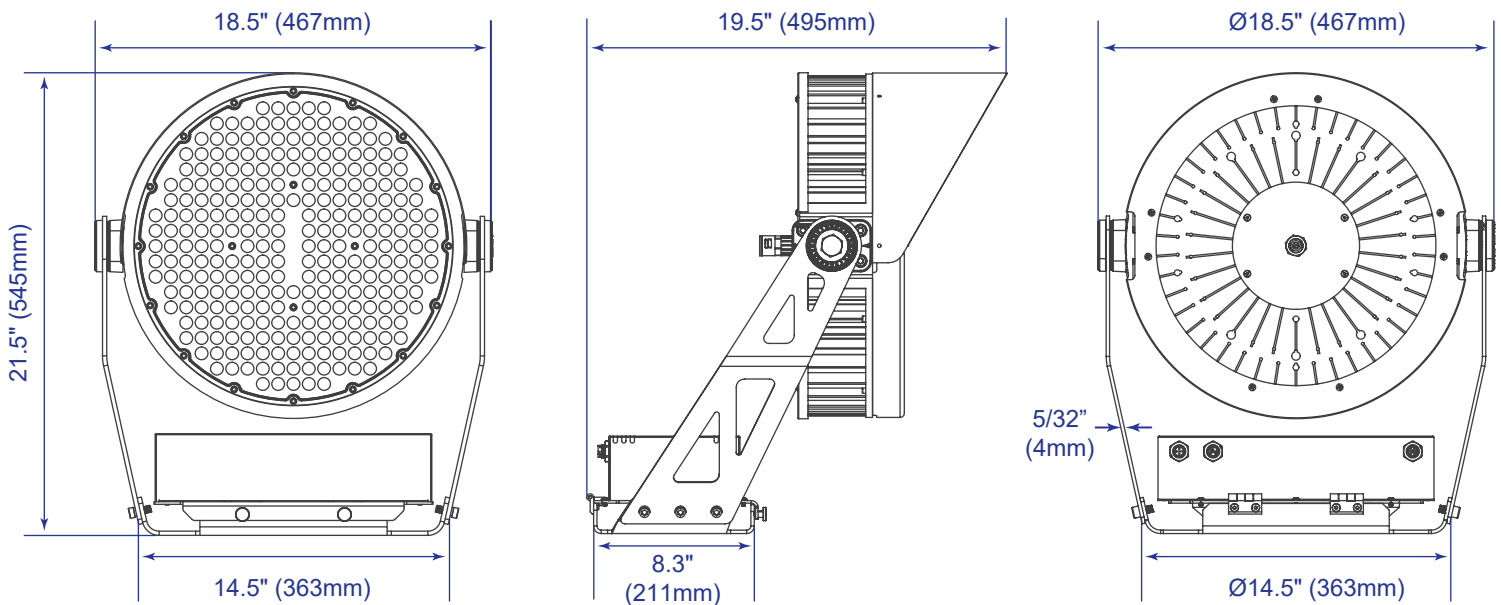

Ordering Nomenclature:

HL	—	APS	—	500WD	—	50K	—	N4	—	277V	—	WH	—	TG
COMPANY		SERIES		WATTS		CCT		NEMA SPREAD		VOLTAGE		COLOR		OPTIONS
				500WD 750WD		40K = 4000K 50K = 5000K 57K = 5700K		3 4 6		277V = 120V-277V 480V = 347V-480V		WH = White BZ = Bronze GY = Gray BK = Black	See Options, below	

Options:

- TG Tempered Glass
- PCK-7 Photo Control Receptacle Kit Only (Photocell not included)

Important Note:

Standard CCT: 5000K
Other CCT'S available as "Special Order" only and with Longer Lead Times

Important Note:

Standard Color: Signal White. Other Colors available as "Special Orders" only and with Longer Lead Times

AEON PNR-Series Installation Manual

Warning: Before beginning Installation, please ensure that you have verified the Safety of Existing Power Distribution Systems.



- Prior to Installation, an Analysis must be Performed to Verify Site Power Meets these Requirements. The Electrical Power must be Clean and have Stable Voltage, Current and Undistorted Waveforms. If the Power **DOES NOT** meet this Criteria, Waveform Correction Technology should be used to Condition the Power. The Surge Protection alone is not adequate. AEON™ will not be liable for damage to Luminaires due to Poor Power Quality. Failure to Follow this Warning may lead to Luminaire Damage and/or Failure and will Void All Warranties.
- The AEON™ LED Luminaires are only installed on their own, independent Circuit. They must not be shared on the same Circuit which also uses other Heavy Equipment or any HID Luminaires. Failure to Follow this Warning may lead to Luminaire Damage and/or Failure and will Void All Warranties.

Hylite is providing this information to the general public only. Please note that all products contained herein are either Trademarked, Copyrighted, and/or have Patents or Patents Pending. Any use of these Designs is Strictly Prohibited. Hylite LED, LLC. Protects its Proprietary Information Vigorously in the Courts of the United States of America.



Table of Contents

Safety Warnings	2-3
Specifications.....	3
Required Materials & Tools for Mounting.....	4
Mounting Hardware	4
Mounting Bracket	5
Tenon Adaptor.....	5
Tilt and Orient Angles.....	6
Standard & Inverted Mounting.....	6-8
Universal Round & Square Pole Adaptor.....	9
Round and Square Pole Mounting.....	10
Tenon Mounting.....	11
Yoke Mounting & Safety Cable Installation.....	12
Photo-Control Mounting.....	12
Labeling & Wiring Connections.....	13-16
Wireless Lighting Controller.....	14
Aiming and Adjustments	17-18
Care & Maintenance	19

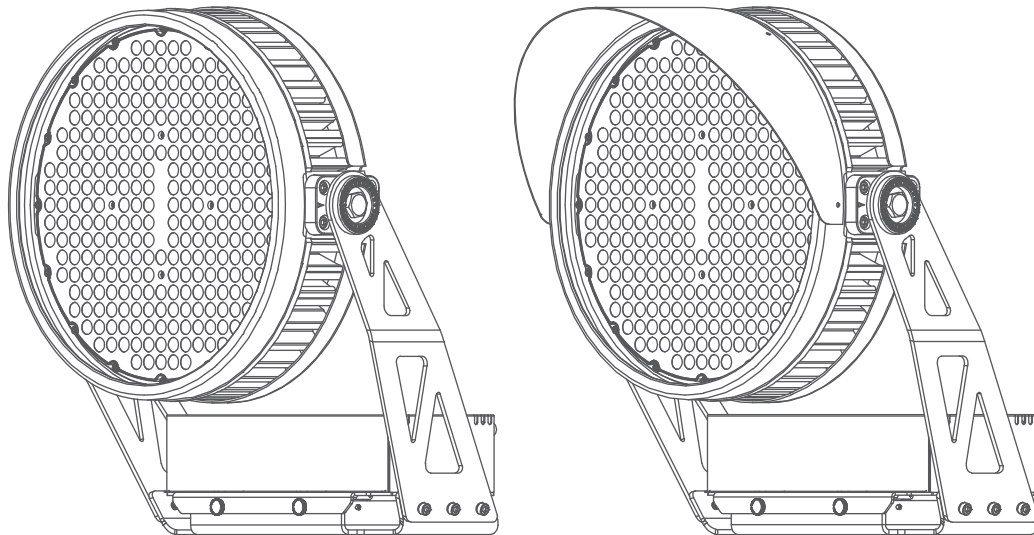

NO
LEAD, MERCURY,
HEAVY METALS
OR TOXIC GASES



This Manual applies to the following Models:

Sports Light: HL-APS-500WD and HL-APS-750WD

Flood Light: HL-APF-500WD and HL-APF-750WD

Note: Flood Light comes without Visor/Glare Shield and Laser Pointer

Thank you for purchasing the AEON™ and for investing in the future of Eco-Friendly products. By selecting AEON™, you have chosen a High-Quality, Eco-Friendly product that is Designed for Years of Dependable Performance. Properly cared for, the AEON™ will give you an extended Life of Trouble-Free Performance. We trust you will experience years of Reliable Service from it. Please store this Installation Manual, for future reference.

This Guide explains the steps necessary to install AEON™. This guide is for reference only and is intended for Certified Electricians who are familiar with the Construction and Operation of the Product and the Hazards Involved. This Guide does not purport to cover all details or variations in Equipment nor to provide every possible Contingency to meet in connection with Installation, Operation, or Maintenance. Should further information be desired, or should particular problems arise which are not covered sufficiently for the Owner's purposes, this matter should be referred to Hylite LED, LLC.



For Your Own Protection Read, Understand and Strictly Observe These Safety Rules and All Instructions Before Attempting to Assemble, Install or Operate This Product!



AEON™ will not accept any Responsibility for Injury, Damage, or Loss which may occur due to Improper or Careless Handling, Incorrect Installation, Operation, or Maintenance of its Products.

Warning - Important Safety Instructions. Risk of Serious Personal Injury, Fire and/or Electric Shock

Read and Understand the detailed Installation Instructions before installing the AEON™ LED Luminaire. When using Electrical Equipment, basic Safety Precautions **MUST** always be followed including the following:

- Risk of Fire or Electric Shock. The AEON™ Installation requires knowledge of Luminaires Electrical Systems. All Inspections, Installation, Servicing or Removal of this product **MUST** be performed by a Certified Electrician only and in accordance with ALL the Applicable National (NEC), State and Local Electrical Codes and Ordinances. Failure to do so may result in a Serious Personal Injury. If not Qualified, **DO NOT** attempt Installation. Contact a Licensed Electrician.
- Disable, Disconnect or Turn-off Power to the Luminaire before Inspection, Installation, Servicing or Removal. **NEVER** Disconnect the Terminals until the Power is switched "OFF". Failure to do so will create a Hazardous and Fatal Working Environment. Verify the Safety of Existing Power Distribution System before beginning Installation. Failure to follow Operating Instructions May Lead to Property Damage, Severe Injury or Death. Always Connect Ground Lead to Luminaire in accordance with National Electrical Codes and Local Electrical Codes and Ordinances where applicable. Failure to do so may result in Serious Personal Injury. Install and use the Luminaires **only** in Environments for which the product is Specifically Marked.
- Install this Luminaire where the Supply Voltage of the Luminaire does not exceed as specified on the AEON™ LED Luminaire. Verify that Supply Wiring Voltage matches Power Supply Voltage by comparing it with the Power Supply Label. Improper Voltage matching can result in Performance Degradation and/or Physical Damage.
- If a NEMA® Photo Control is installed refer to NEMA® Receptacle manufacturer for Wiring Instructions.
- Luminaire Wiring, Power Supply, or other Electrical Parts may be Damaged when Drilling for Installation. Inspect Wiring and Components for Damage before Turning on Power. Proper Grounding is essentially required for Safety.
- If Mounting Bolts are completely removed in the field they should be Hand Threaded (prior to use of Power Tools) to ensure proper engagement of the Thread when reinstalling. Failure to Pre-start threads may result in Cross-threading or Stripping of the Bolts during Reinstallation.
- **DO NOT** Damage or Cut the Wire Insulation during Installation. To Prevent Wiring Damage or Abrasion, **DO NOT** Expose Wiring to edges of Sheet Metal or other Sharp Objects.
- **DO NOT** Make, Alter, Relocate or Remove Wiring, Power Supply or any other Electrical Component. Changes of the Design and Modifications to the AEON™ LED Luminaire are strictly prohibited. **DO NOT** Make or Alter any Open Holes in an Enclosure of Wiring or Electrical Components during Installation.
- **DO NOT** Mount or Support this Luminaire in a manner that can Cut the Outer Jacket or Damage Wire Insulation. Make sure all Connections are secure using only approved Connecting Devices. The AEON™ LED Luminaire can under No Circumstance be Mounted on any Flammable Surfaces. Keep all Combustible and other materials that can burn, away from Luminaire/Lens. **DO NOT** Operate in Close Proximity to People, Combustible Materials or Substances affected by Heat or Drying.
- To avoid Possible Damage to the Eyes, avoid being in front of a Luminaire that is ON. Do not stare into an LED Beam. LED Luminaires are Extremely Bright. Wear Protective Welding or Laser Safety Eyewear.
- Avoid Touching any External Surface of the Luminaire In use, due to the possibility of High Temperatures. **TURN-OFF** Electric Power to all affected Circuits and allow to Cool before Servicing.
- **DO NOT** Restrict Luminaire Ventilation. Allow for some Volume of Airspace around the Luminaire. Avoid Covering LED Luminaires with Insulation, Foam, or Other Material that will Prevent Convection or Conduction Cooling.
- LED products are Polarity Sensitive. Ensure proper Polarity before Installation.
- Electrostatic Discharge (ESD): ESD can damage LED Luminaires. Personal Grounding Equipment must be Worn during all Installation or Servicing of the Unit. **DO NOT** Touch Individual Electrical Components as this can cause ESD, Shorten Lamp Life, or Alter Performance.
- **WARNING:** Dangerous Voltages Exist within the Unit and all Precautions in Handling High Voltage Equipment should be Strictly Observed when replacing the Light Engine or otherwise Servicing the Luminaire. **Disregarding this Warning could result in Electrical Shock and Severe Injury, Property Damage or even Death to the Individual Installing or Servicing this Luminaire.**
- The AEON™ LED Luminaire is a New Generation, High-Tech Solid-State Luminaire. To Protect your Investment, you should ensure that the Electrical Power must be Clean and have Stable Voltage, Current and Undistorted Waveforms. Installing a Surge/Lightning Protection and Waveform Correction Technology Device prior to Installation on each Circuit Panel or Power Supply Feed Powering the AEON™ LED Luminaire is Highly Recommended as it helps to Eliminate Premature Driver Failure caused by Surges and other Power Fluctuations.
- Store Luminaires in a Clean, Dry Place, Protected From Dirt, Water and Direct Sunlight. See Table below for required Storage and Operating Conditions:

Storage Temp.: -40°F to 140°F / (-40°C to +60°C)	Suitable for Ambient Temp.: -40°F~+122°F (-40°C~+50°C)	Humidity 5% to 95% (Non-Condensing)
--------------------------------------------------	--------------------------------------------------------	-------------------------------------

Notice: Risk of Product Damage: Failure to Strictly Follow all Instructions could Result in Damage to the Product and Void ALL Warranties!

SAFETY FIRST

Your Safety is very important to us. It is extremely important that you read the entire Installation Manual to become familiar with the Luminaire before you begin to Install the unit. Properly cared for, the AEON™ will give you an extended time of trouble-free performance. Please store this Installation Manual, for later reference.



Before beginning Installation please ensure that you have verified the Safety of Existing Power Distribution Systems. Failure to follow these Instructions may result in Electrical Shock and Severe Injury, Property Damage or even Death to the Individual Installing or Servicing this Luminaire.

- **Always Wear Appropriate Protective Clothing and Equipment. DO NOT** wear Loose Clothing or Jewelry. They can be caught in Moving Parts. Approved Electrical Protective Gloves, Impact Resistant Safety Glasses or Safety Goggles, Hard Hats, Reflective Vests, Fall Protection Equipment and Safety, Non-Skid Toe Boots are strongly recommended for Installer's Protection.
- **Stay Alert.** Watch what you are doing. Use Common Sense. **DO NOT** Install the Luminaire when you are Tired or under the influence of any medications. **Be Alert at All Times.** You may have demonstrated a certain product hundreds of times, but do not be lulled into Complacency due to a False Sense of Security. Tools can be extremely unforgiving if not used carefully and as per instructions.
- **DO NOT Over-reach.** Keep Proper Footing and Balance at all times.
- **Keep Visitors Away.** All Visitors must be kept away from Work Area.

SPECIFICATIONS

AEON Model	500WD	750WD
Luminaire Wattage	500W	750W
Delivered Lumens	91,300	113,880
Variable Dimming Control	0-10VDC	0-10VDC
Current Draw @120V	4386mA	6579mA
Current Draw @208V	2530mA	3796mA
Current Draw @240V	2193mA	3289mA
Current Draw @277V	2006mA	3008mA
Current Draw @347V	1601mA	2402mA
Current Draw @480V	1157mA	1736mA
Effective Projected Area (EPA)	2.25 Sq. Ft.	2.25 Sq. Ft.
Net Weight	45 lbs. (20.5 kg.)	49 lbs. (22 kg.)

- Input Voltage: 100-277VAC and 347-480VAC
- LED's Lifetime (L70 Hrs. at 70°C): >158,000 Hours
- Driver Lifetime: 220VAC Input (80% Load @ 70°C Case Temperature): >81,000 Hours
- Driver Lifetime: 480VAC Input (80% Load @ 70°C Case Temperature): >110,000 Hours
- Operating Temperature Range: -40°F~+104°F (-40°C to 40°C)
- Surge Protection (Line-Line): 6kV; Surge Protection (Line-Ground): 10kA / 20kV
- IP Rating: IP66; NEMA Rating: 4X

Important Note: The Specifications Listed were obtained under Optimal Testing Conditions. Changes in Options, Features and Conditions may result in slightly different Performance Specifications among Luminaires.

Warning: Before beginning Installation, please ensure that you have verified the Safety of Existing Power Distribution Systems.



- Prior to Installation, an Analysis must be Performed to Verify Site Power Meets these Requirements. The Electrical Power must be Clean and have Stable Voltage, Current and Undistorted Waveforms. If the Power **DOES NOT** meet this Criteria, Waveform Correction Technology should be used to Condition the Power. The Surge Protection alone is not adequate. AEON™ will not be liable for damage to Luminaires due to Poor Power Quality. **Failure to Follow this Warning may lead to Luminaire Damage and/or Failure and will Void All Warranties.**
- The AEON™ LED Luminaires are **only installed on their own, independent Circuit.** They **must not be shared** on the same Circuit which also uses other Heavy Equipment or any HID Luminaires. **Failure to Follow this Warning may lead to Luminaire Damage and/or Failure and will Void All Warranties.**

Installing a Surge/Lightning Protection and Waveform Correction Technology Device prior to Installation on each Circuit Panel or Power Supply Feed Powering the AEON™ LED Luminaire is Highly Recommended as it helps to Eliminate Premature Driver Failure caused by Surges and other Power Fluctuations. Pure, Clean Power is Essentially Required to Ensure Proper Function and Lifetime of AEON™ LED Luminaires. Consult your Lighting Representative at AEON™ for more information.

Contents: Luminaire, Glare-Shield with Mounting Hardware, Safety Cable with Locking Snap Hook, Laser Pointer with Mount (1 pc. per order) and Installation Manual. **Specification of the Replacement Battery for Laser Pointer: RCR123A / 16340 600mAh, 3.7V Lithium Ion (Li-ion) Button Top Battery.**

Required Materials & Tools:

- Socket Wrench or Adjustable Spanner Sized for 1/2" (12mm) and 3/4" (20mm) Bolts.
- 6mm Allen Hex Socket Wrench (for 6mm Angle Locking Screw) and 10mm Allen Hex Socket Wrench for Tenon Adapter.
- Torque Wrench Rated to a Minimum of 35 Ft-Lb.
- Cable Ties or Wire Management
- Phillips Head Screwdriver
- Light Meter

Installation: We designed the AEON™ LED Luminaire for Easy Installation and Usage. Please Read this Manual completely BEFORE attempting Installation and Operation.

Warning: It is the responsibility of the installer to verify that all Proposed Mounting Structures including Poles, Cross Arms, Catwalk Brackets, and other Mounting Structures are Certified to Support the Weight of the Luminaires, withstand Wind Loads, and Meet all Other Applicable Codes and Regulations before beginning the Installation Process.

DO NOT Suspend any Luminaire by Electrical or Control Wires, as these will not Support the Weight of the Luminaire, resulting in the potential for the Luminaire to Fall and cause Damage or Injury. An Eye Hook is provided Standard with each AEON™ LED Luminaire for Lifting or Suspending the Luminaire. Failure to Follow these Warnings May Lead to Severe Injury, Property Damage or even Death.

Caution: Handle the new AEON™ LED Luminaire with Care. **DO NOT** set the Luminaire down on the Lens. Protect Lenses when Setting Luminaire down.

Glare Shield Installation

Install Four M5 x 10mm Round Head Screws (Included) through the Glare Shield and affix to the Luminaire as shown in the illustration. Tighten the Screws to ensure that the Glare Shield is Secure.

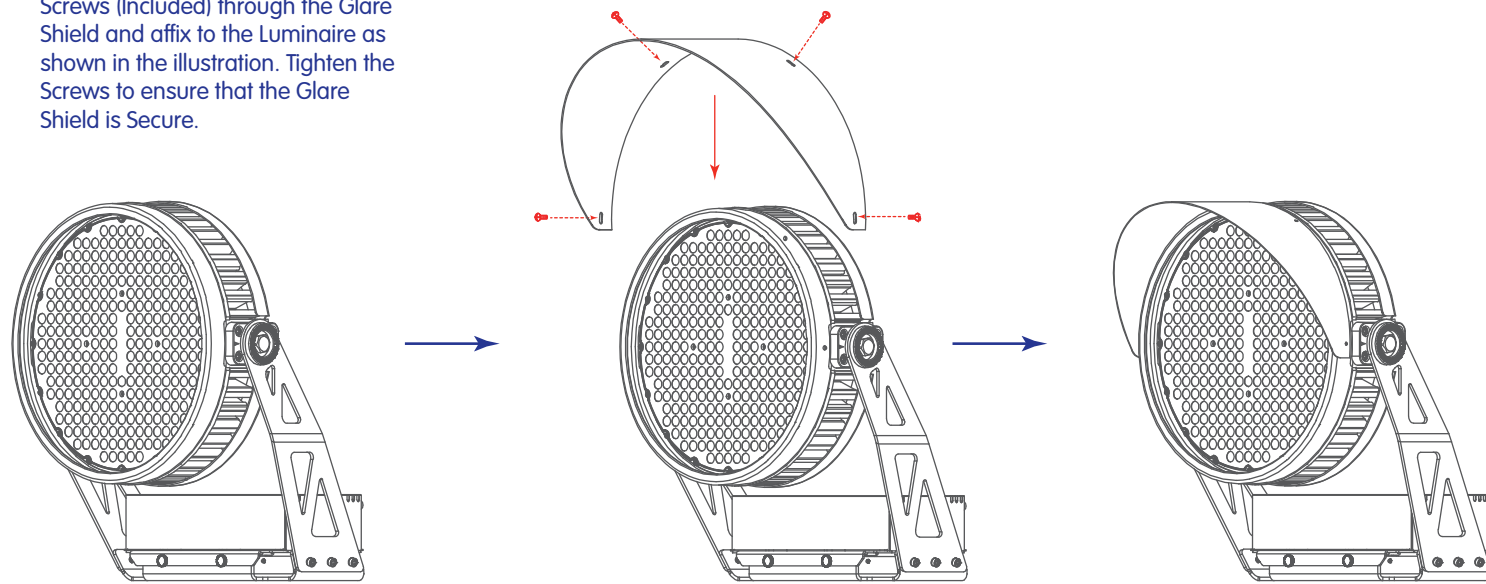

Mounting the Luminaire: The first step is to attach the Luminaire to the Mounting Structure. The Mounting Structure may be a Pole, Cross Arm, an Indoor Catwalk Bracket or other Structural Component that will hold the Luminaire in place. Refer to Photometrics or Project Installation Drawings for Luminaire Installation Locations and any additional Mounting Instructions.

Caution: Before Installation, verify there are no Obstructions in the Designed Luminaire Locations and Light Paths. If any other Obstructions are present, shift the Mounting Location up to +/-2 ft. (60cm) in either direction to Install the Luminaires in the closest available Location to provide a Clear Conical Light Path from the Luminaire to a 20 ft. (6M) diameter circle around the aiming point that is Completely Free of Obstructions. All LED Arrays in each Luminaire must have Clear Line of Sight to Aiming Area. **DO NOT install the Luminaire Partially Obscured.**

For 7/8" (22mm) Hole

For 1/2" (13mm) Hole

Hardware Required	Size	Quantity per Luminaire	Size	Quantity per Luminaire
Hex Bolt & Locknut	3/4" (19mm)	1	1/2" (12mm)	1
Spring Washer	3/4" (19mm) ID	1	1/2" (12mm) ID	1
Flat Washer	3/4" (19mm)	2	1/2" (12mm)	2

Important Note: Mounting Hardware must be Stainless Steel or of other High-Strength, Corrosion-Resistant Material. Length of Hex Bolt shall be determined in the Field. Size the Bolt appropriately to allow Secure Fastening of the Luminaire to the Mounting Structure.

Warning: NEVER use any Power Tools on the Luminaire while the Power to the Luminaire is ON. The Vibration caused by the Power Tools will Damage the Luminaire. Failure to Follow this Warning may lead to Luminaire Damage and/or Failure and will Void All Warranties.

Mounting Bracket

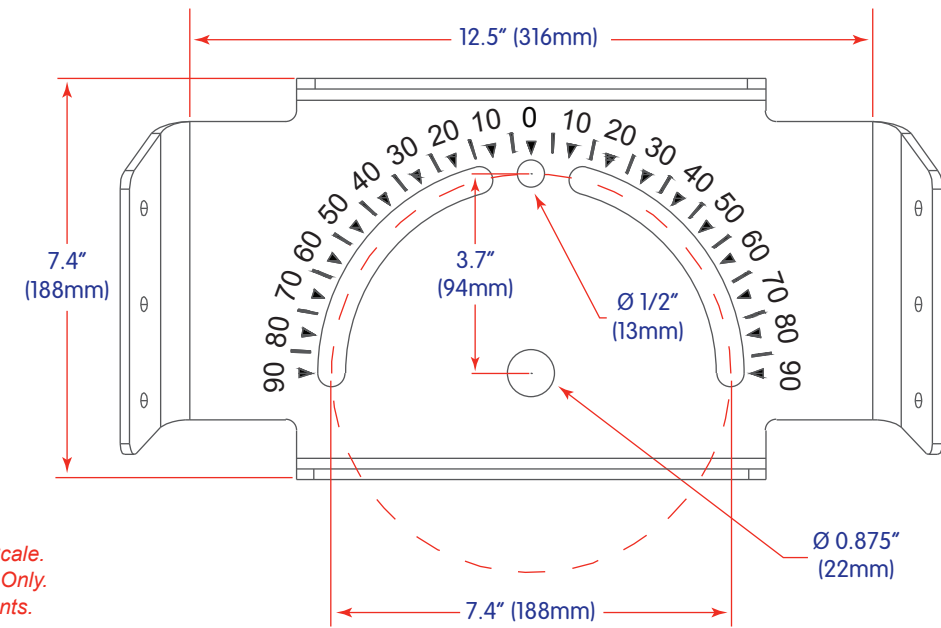

Note: Drawings not to Scale. For illustration Purpose Only. Please use Measurements.

Tenon Adaptor for 2" (51mm) Pole or Tenon [2.38" (65mm) O.D. max.]

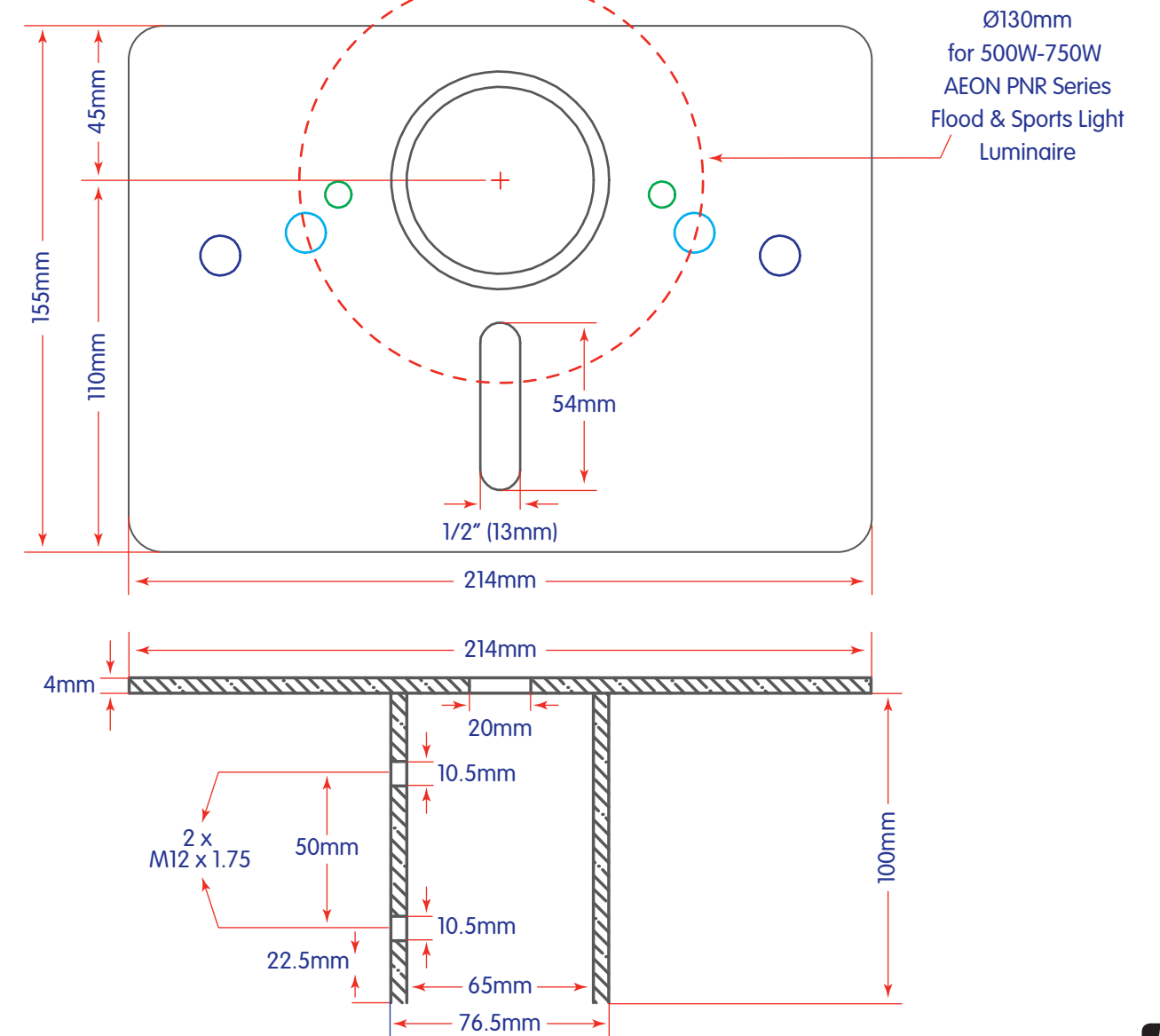

AEON Tilt and Orient Angles

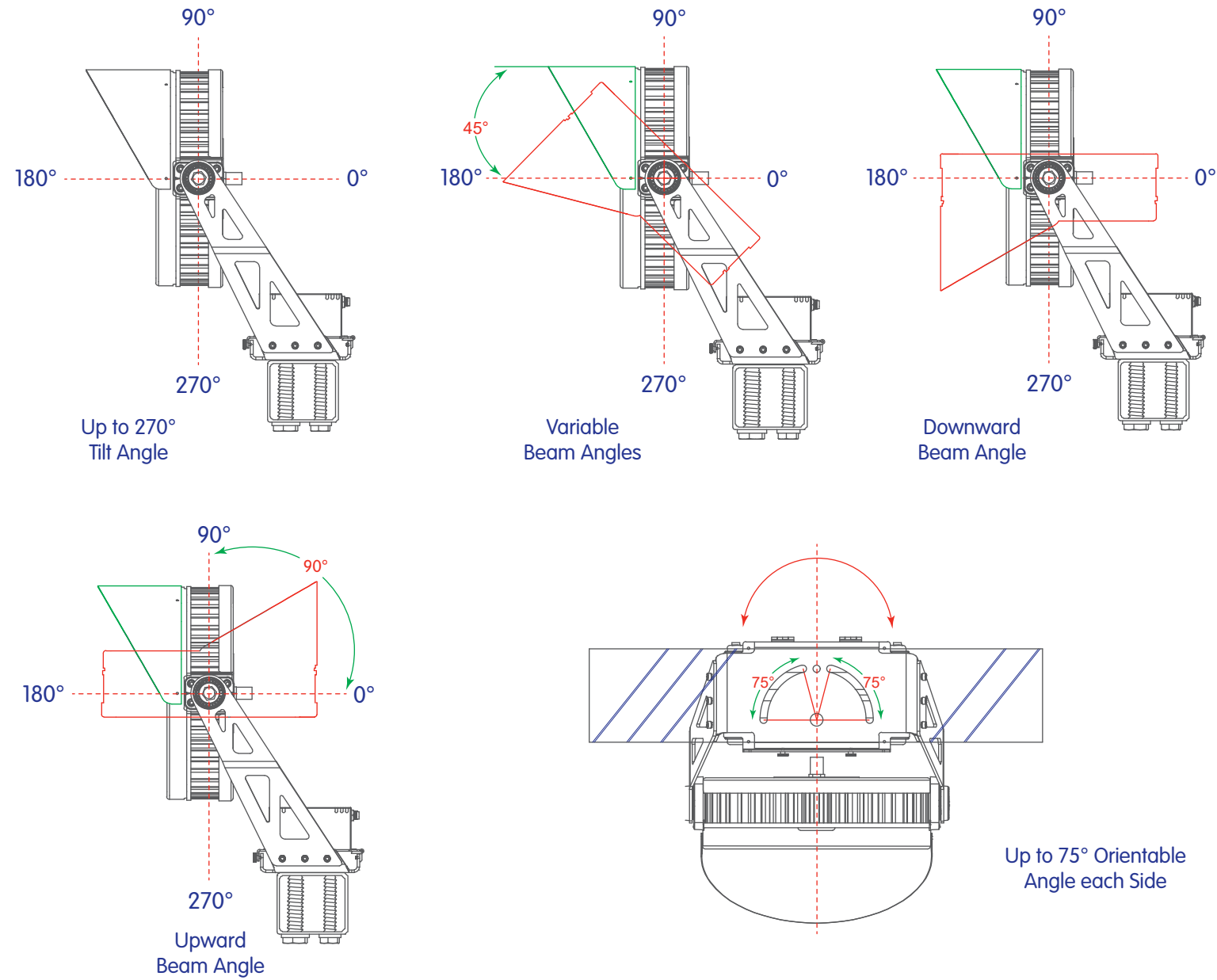

Mounting: The AEON™ LED Luminaire can be mounted in two different ways: Standard or Inverted. Standard Mounting is when the Luminaire sits on Top of the Mounting Structure, and Inverted Mounting is when the Luminaire hangs from Underneath the Mounting Structure.

Warning: **DO NOT** Suspend any Luminaire by Electrical or Control Wires, as these will not Support the Weight of the Luminaire, resulting in the potential for the Luminaire to Fall and cause Damage or Injury. A Safety Cable is provided Standard with each AEON™ LED Luminaire for Lifting or Suspending the Luminaire. Failure to Follow this Warning could result in Electrical Shock and Severe Injury, Property Damage or even Death to the Individual Installing or Servicing this Luminaire.

Standard Mounting: This is the most common Mounting. The Luminaire sits on Top of Mounting Structure.

1. Refer to the Photometrics or Project Installation Drawings to determine Luminaire Installation Locations and the Lens-Type. For each Luminaire Location, install a Luminaire that has the correct Lens-Type.
2. Remove 2 Knobs from the Front Side of the Driver Box and Flip it Upwards.
3. Set Luminaire in place and Install Bolt, Washers, and Nut to securely fasten the Luminaire Mounting Bracket to the Mounting Structure. Hand tighten the Bolts so that Luminaire is Secure but, do not fully Torque the Bolts until Aiming is complete.
4. Flip the Driver Box Downwards and install the 2 Knobs on the Front Side of the Driver Box. Hand tighten both the Knobs so that the Driver Box is Secure.
5. Remove the Clear Protective Film from the front of the Lenses, if present. Now the Luminaire is ready for application.

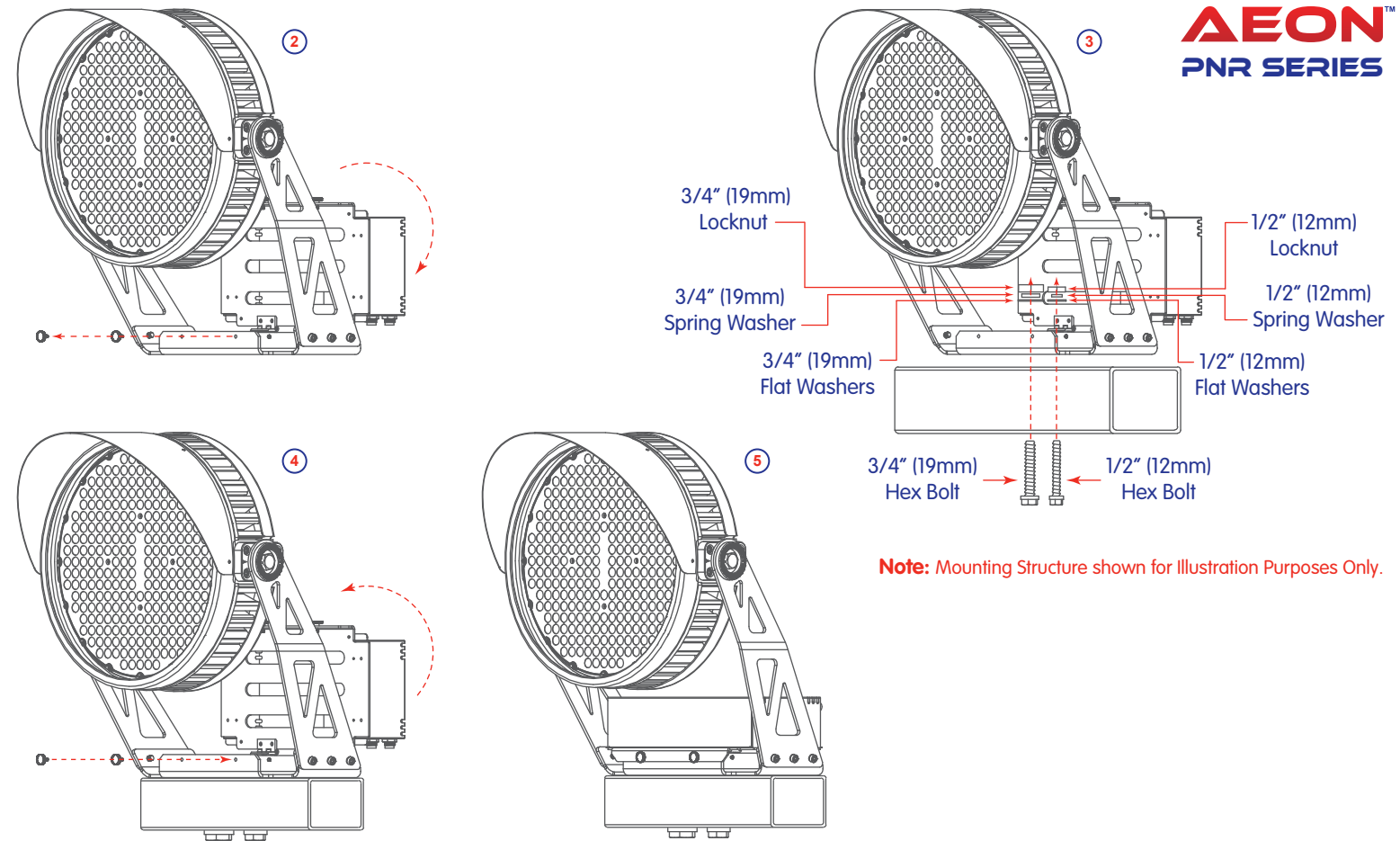
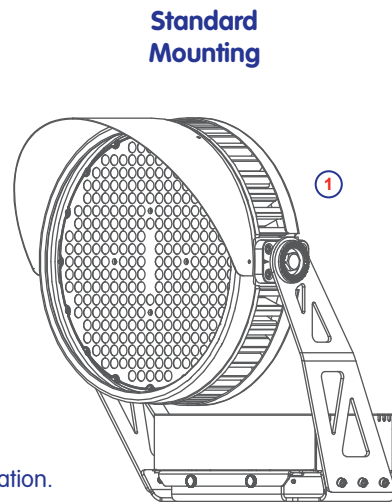

Note: Mounting Structure shown for Illustration Purposes Only.

Inverted Mounting

The Luminaire hangs from underneath the Mounting Structure.

Warning: When using Inverted Mounting, Flip the Mounting Bracket so that the Luminaire stays Upright. NEVER install the Luminaire Upside Down. **DO NOT** Suspend any Luminaire by Electrical or Control Wires, as these will not Support the Weight of the Luminaire, resulting in the potential for the Luminaire to Fall and cause Damage or Injury. An Eye Hook is provided Standard with each AEON™ LED Luminaire for Lifting or Suspending the Luminaire. Failure to Follow this Warning could result in Electrical Shock and Severe Injury, Property Damage or even Death to the Individual Installing or Servicing this Luminaire.

1. Refer to the Photometrics or Project Installation Drawings to determine Luminaire Installation Locations and the Lens-Type. For each Luminaire Location, install a Luminaire that has the correct Lens-Type.
2. Ensure when Installing that the Inverted Luminaire is properly Supported. Remove 2 Knobs from the Front Side of the Driver Box and Flip it downwards.
3. Set Luminaire in place and Install Bolt, Washers, and Nut to securely fasten the Luminaire Mounting Bracket to the Mounting Structure. Hand tighten the Bolts so that Luminaire is Secure but, do not fully Torque the Bolts until Aiming is complete.
4. Flip the Driver Box upwards and install the 2 Knobs on the Front Side of the Driver Box. Hand tighten both the Knobs so that the Driver Box is Secure.
5. Remove the Clear Protective Film from the front of the Lenses, if present. Now the Luminaire is ready for application.

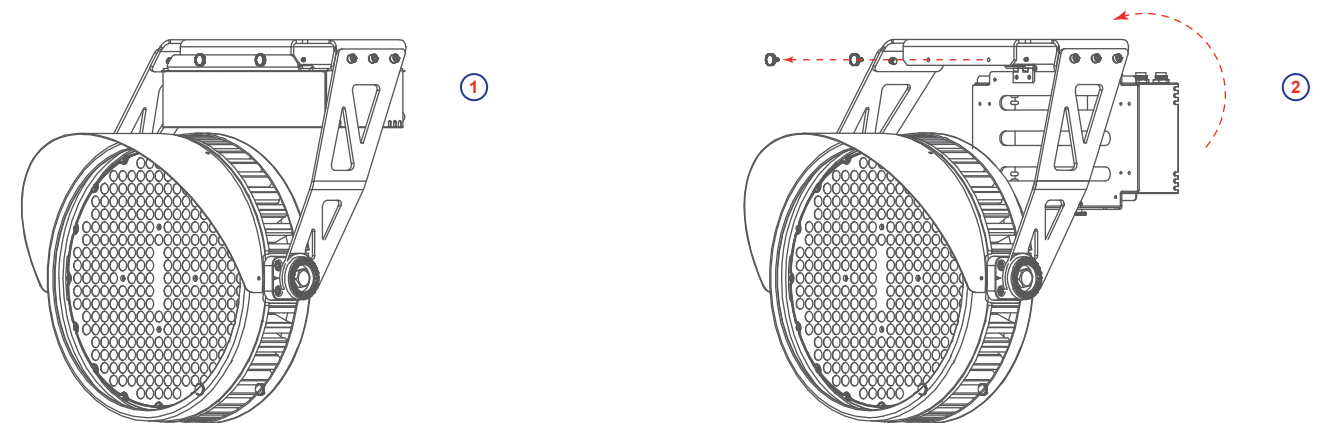

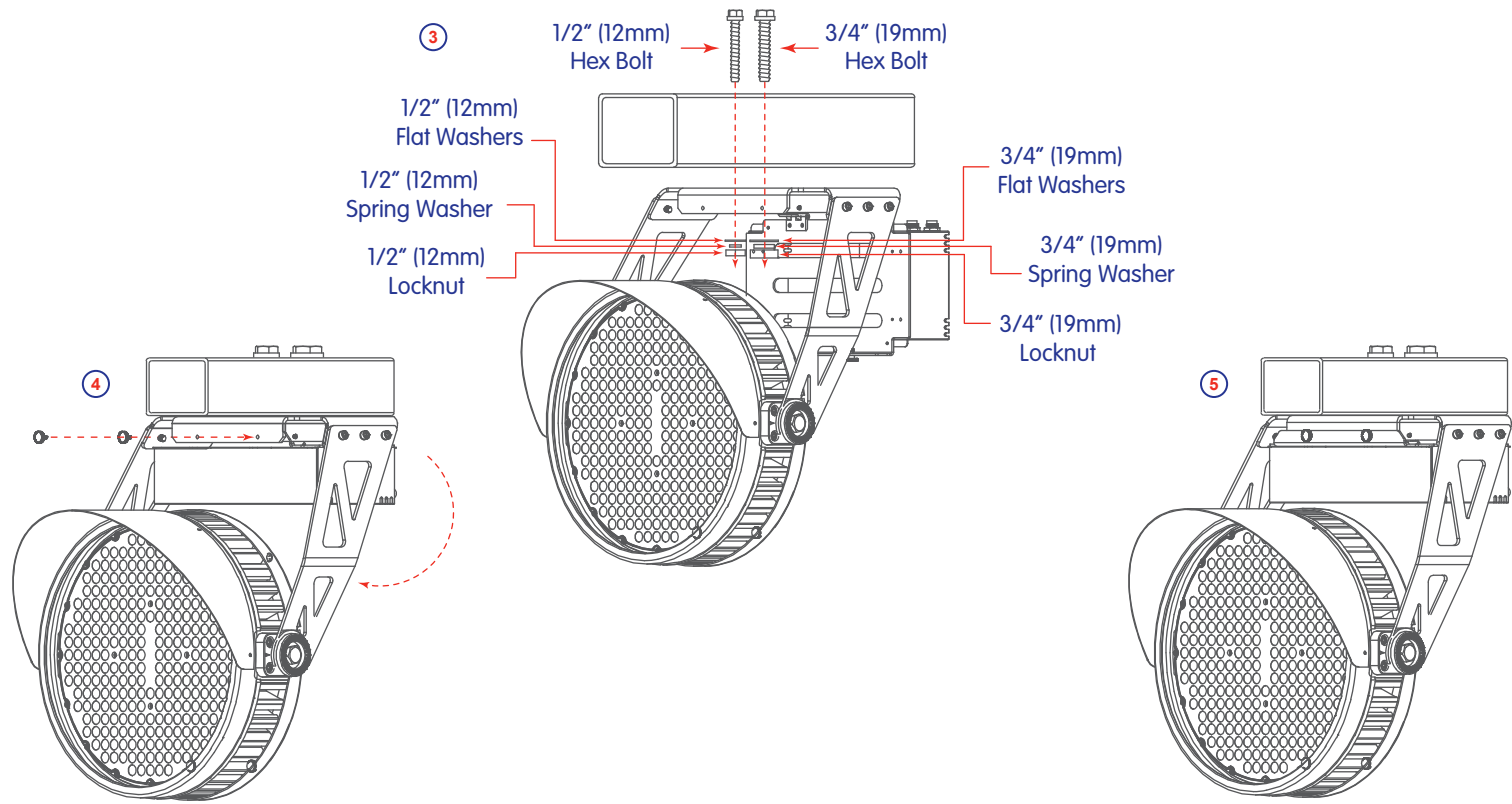

AEON Inverted Tilt Angles

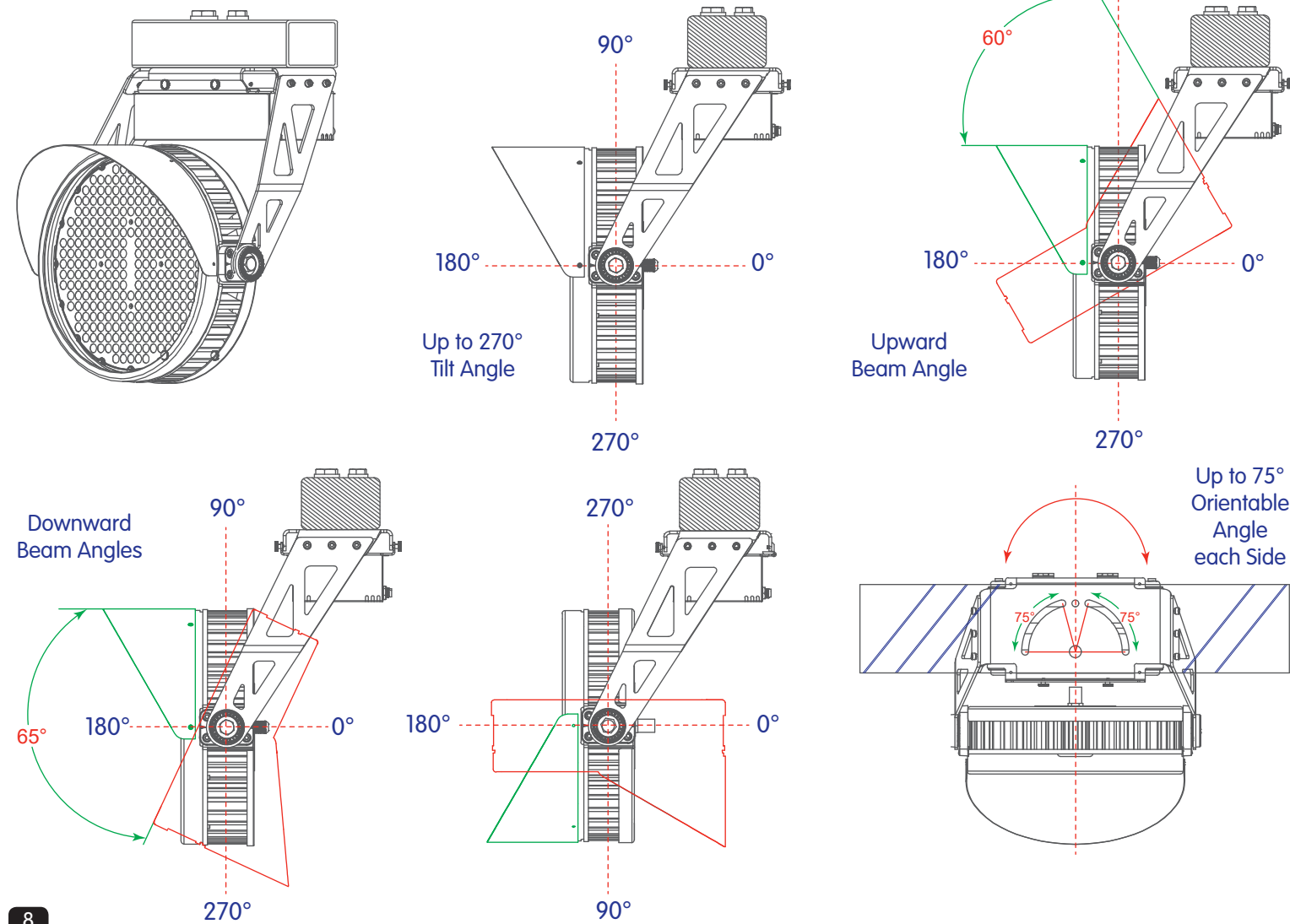

AEON Universal Round & Square Pole Adaptor

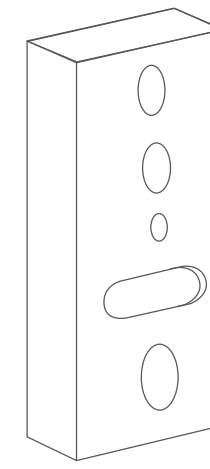

Bolster Plate

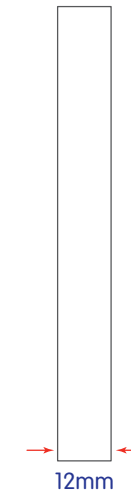

12mm

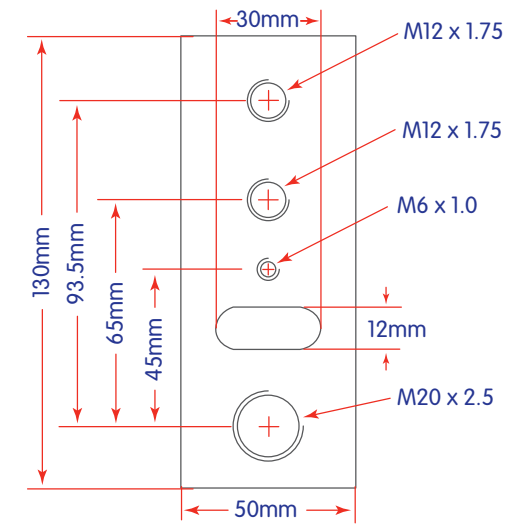

Gasket

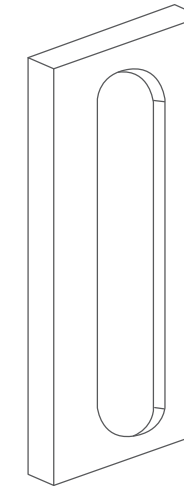

5mm

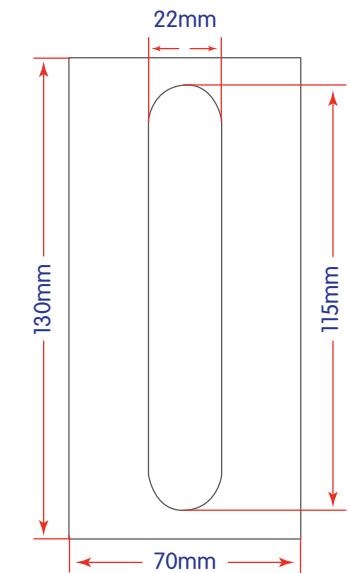

Note: Drawings not to Scale.
For illustration Purpose Only.
Please use Measurements.

Round Pole Adaptor



23mm

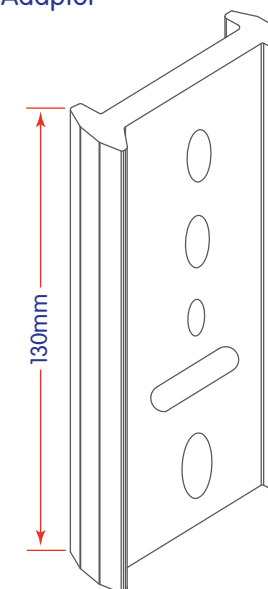

130mm

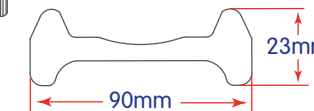

90mm

23mm

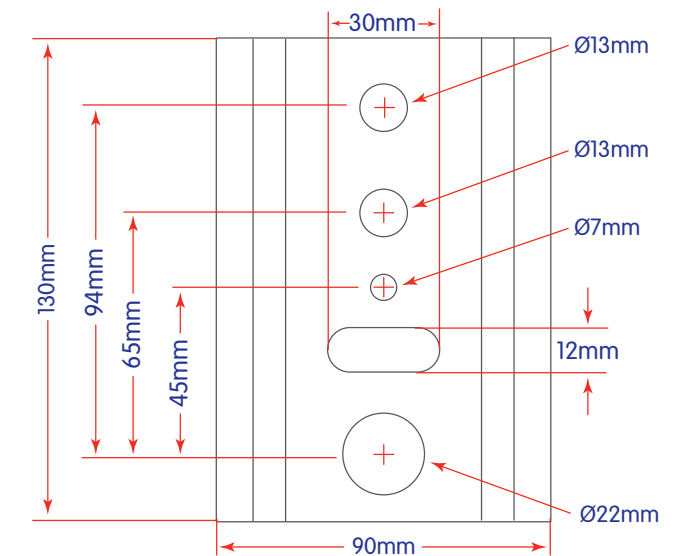

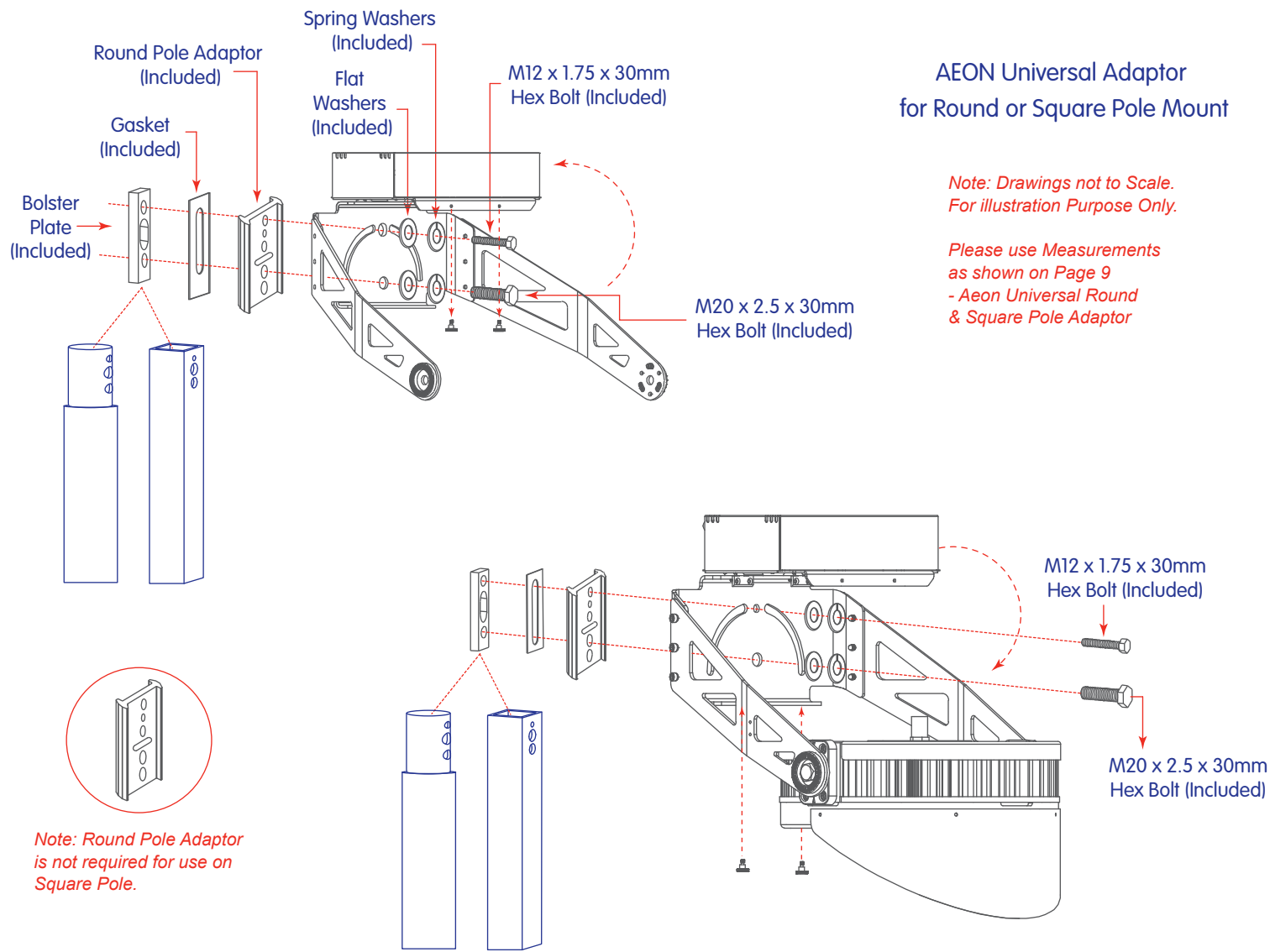

AEON Universal Adaptor for Round or Square Pole Mount

*Note: Drawings not to Scale.
For illustration Purpose Only.*

*Please use Measurements
as shown on Page 9
- Aeon Universal Round
& Square Pole Adaptor*

*Note: Round Pole Adaptor
is not required for use on
Square Pole.*

1. Place the Round/Square Pole Adaptor and Gasket between the Yoke Bracket and Drilled Pole as shown in the illustration.
2. Line-up the Holes of the Gasket and the Adaptor with the Holes in the Pole Drilling Pattern.
3. Feed Supply Wires from the Pole through the Bolster Plate, Gasket and the Adaptor to be connected to the Luminaire. Connect Wire Cord to AC Branch Circuit as per following. It must be in Accordance with Local and National Codes:
 - a. Connect Black Wire to Line (Hot)
 - b. Connect White Wire to Neutral
 - c. Connect Green to Ground
 Connect these Wires to the Supply Wires using Waterproof Wire Nuts (provided). Refer to Pages 9 to 11 for Proper Wiring Instructions
4. Remove 2 Knobs from the Front Side of the Driver Box and Flip-it Upwards.
5. Place the Bolts and Washers through the Yoke Bracket, the Adaptor and Gasket to the Pole and Thread into the Bolster Plate.
6. Set Luminaire in place and install Bolt, Washers, and Nut to securely fasten the Luminaire Mounting Bracket to the Pole. Hand tighten the Bolts so that the Luminaire is Secure but, do not fully Torque the Bolts until Aiming is complete.
7. Flip the Driver Box Downwards and install the 2 Knobs on the Front Side of the Driver Box. Hand tighten both the Knobs securely to ensure the Driver Box is well-secured.

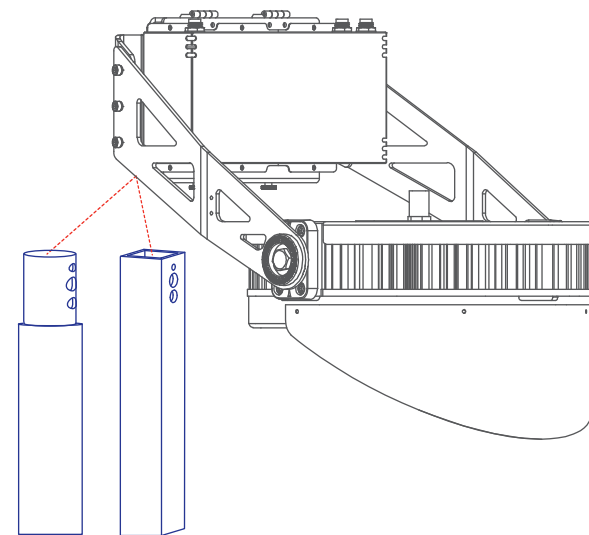

1. Remove 2 Knobs from the Front Side of the Driver Box and Flip-it Upwards.
2. Line up the Holes of the Yoke Bracket with the Holes in the Tenon Adaptor Pattern.
3. Feed Supply Wires from the Pole through the Tenon Adaptor to be connected to the Luminaire.
4. Place the Bolts through the Tenon Adaptor. Set Luminaire in place and Install Bolts, Washers, and Lock Nuts to securely fasten the Luminaire Mounting Bracket to the Tenon Adaptor. Hand tighten the Bolts so that Luminaire is Secure but, do not fully Torque the Bolts until Aiming is complete.

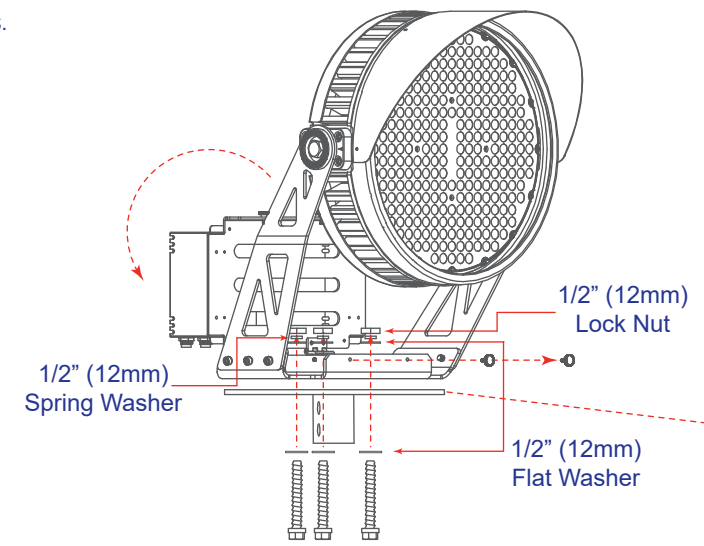

AEON Tenon Adaptor for Pole Mount

*Note: Drawings not to Scale.
For illustration Purpose Only.*

*Please use Measurements as
shown in Aeon Tenon Adaptor
- Page 5*

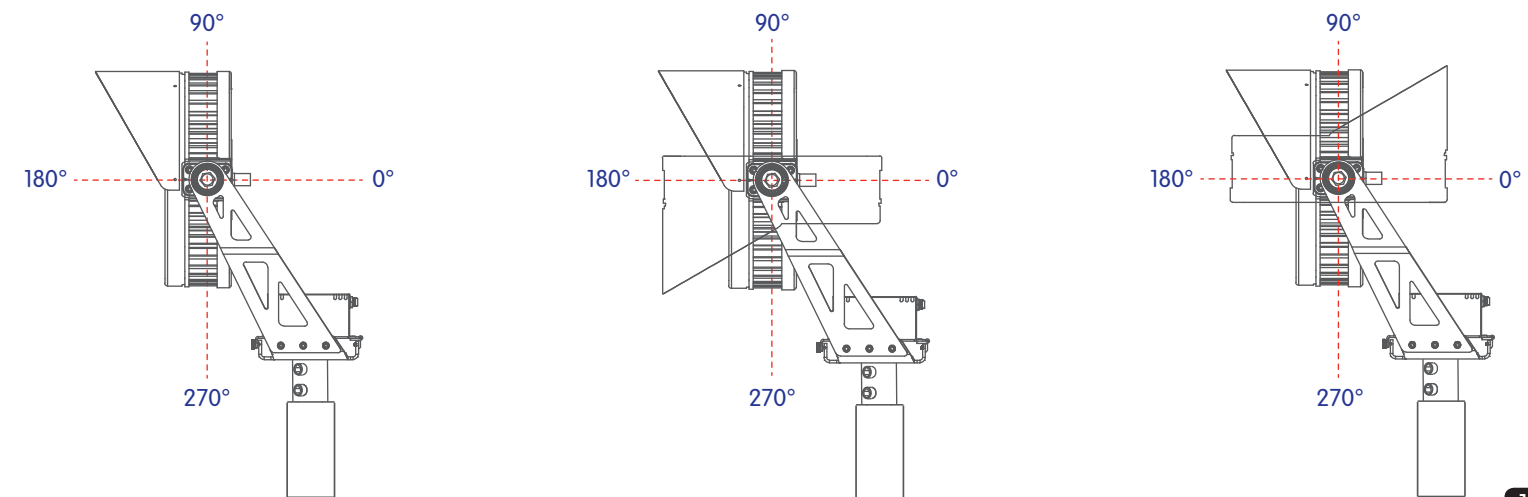
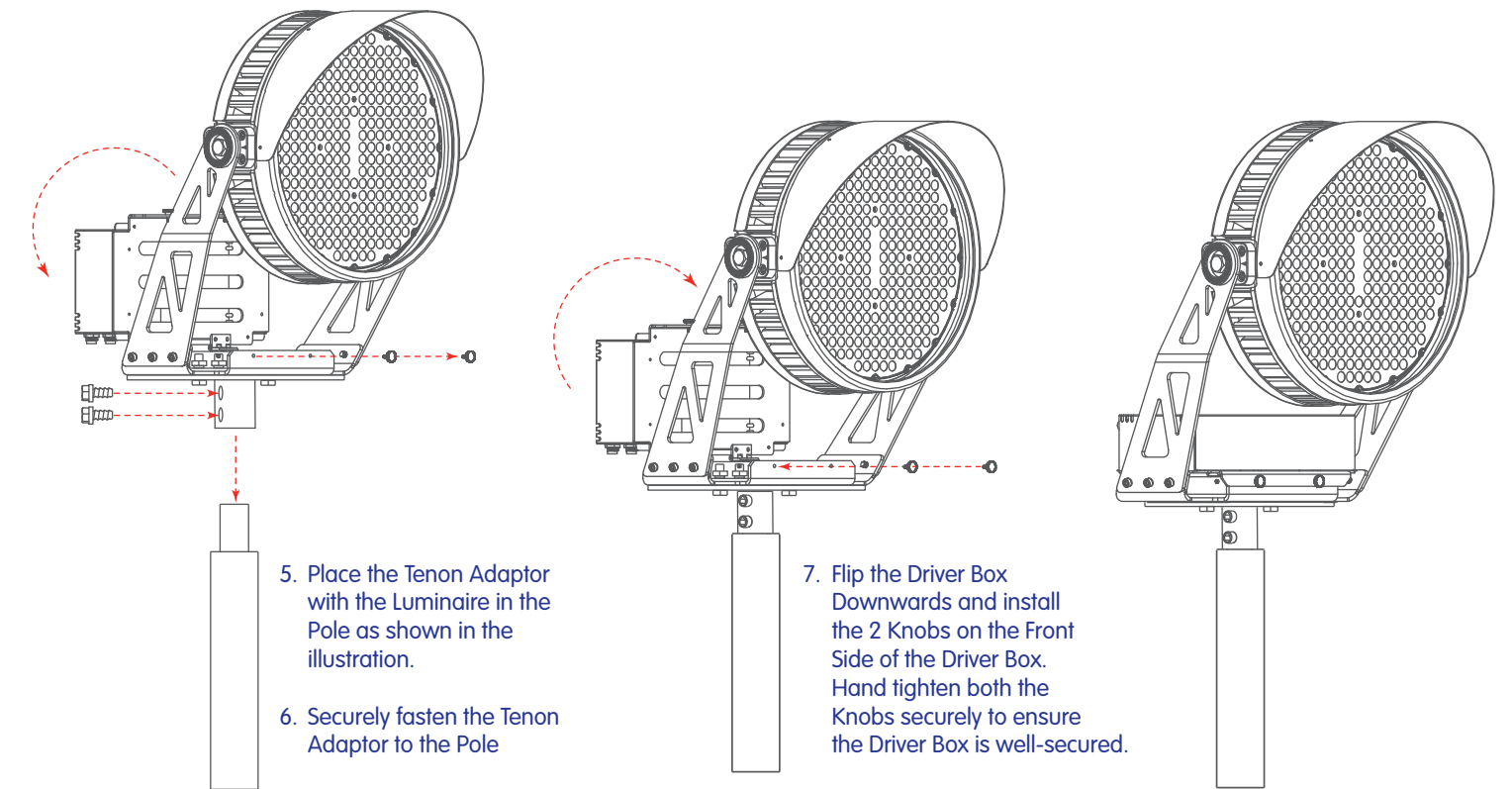
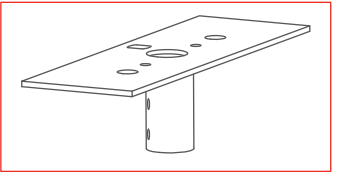

Yoke Bracket: The AEON™ LED Luminaire comes Standard with Fully-Adjustable Yoke Bracket, in 7.5° Increments: 0-90° Orient and 270° Tilt Angle. Loosen Pivot Hex Bolts and Angle Locking Set Screws on each side of the Luminaire (Do Not Remove). Move Yoke Bracket to Desired Position and Lock into place by Tightening M16 (5/8") Pivot Hex Bolts to 45 ft-lb [61 Nm], M20 (3/4") Pivot Hex Bolts to 90 ft-lb [121 Nm], and M8 (5/16") Angle Locking Set Screws to 6-7 ft-lb [8.0-10.0 Nm].

Installation of Safety Cable: When using a Safety Cable, ensure Minimum Slack in Cable after Installation. Connect Safety Cable to the Yoke Bracket of the Luminaire. Ensure it meets all the appropriate Local and Regional Codes and Regulations.

Photo-Control: When used, Photo-Control Receptacle should be oriented so that the letter "N" with arrow is directed toward true North. Install the Photo-Control last.

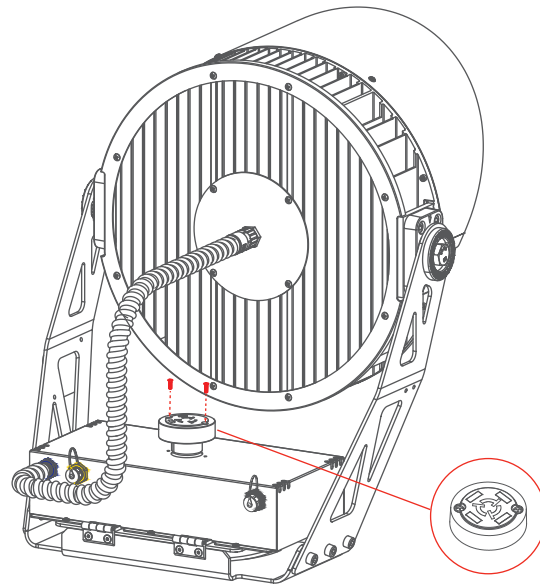

1. Install the Receptacle on the Top of the Driver Box and Screw-in with M4 x 10 Screws (Included). The Receptacle should be oriented so that the letter "N" with Arrow is directed towards true North

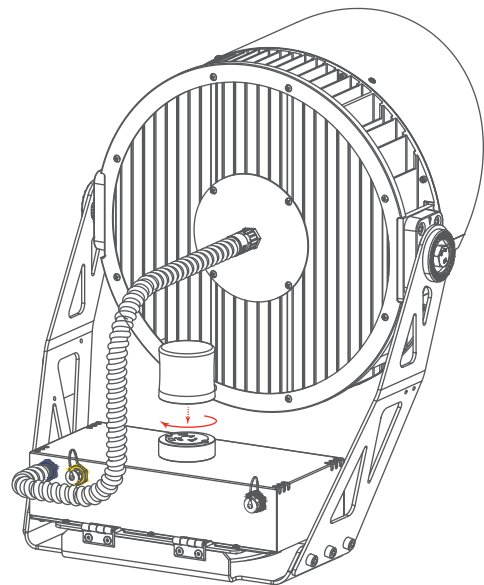
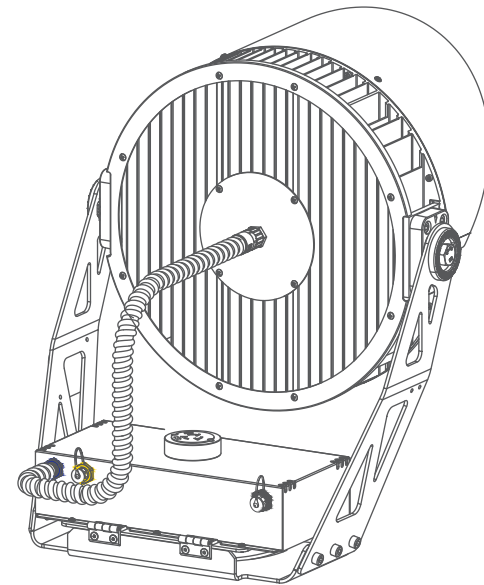

2. Simply Plug-in the Photo Control to the Receptacle and twist Clockwise. Do not install the Photo Control so that it directly faces the mid-day Sun

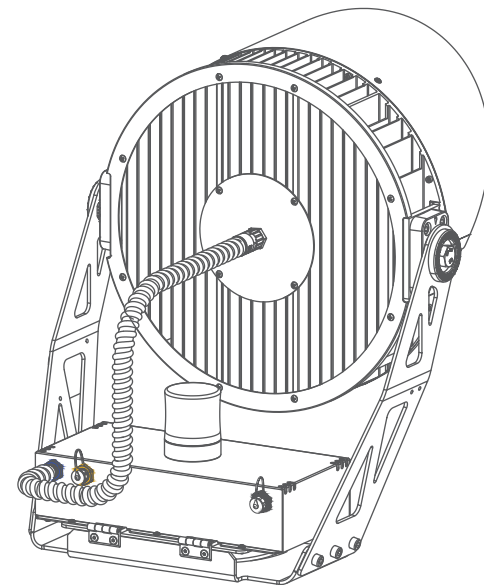

- Caution:**
1. Position and mount the Photo-Control so that no Artificial Light will cause the Photo-Control to accidentally turn-off at Night.
 2. Luminaire will turn ON initially and then turn OFF within 2 minutes if the Photo-Control is tested in Daytime. For further Testing cover the Photo-Control completely with Black Tape or another Dark Material to simulate Night Conditions. If the Luminaire is tested at Night, use a Flashlight and shine the Light directly on the cell. The Luminaire should turn off in less than 2 minutes.

Labelling the Luminaires (If Required)

Labeling a Luminaire can be helpful in ensuring that proper Luminaires are installed in the right locations. Additionally, since AEON™ LED Luminaires can be controlled individually or in groups, labeling a Luminaire can aid in setting up the Control Systems. For Applications where many Luminaires are Installed and the Luminaires are typically labeled to facilitate identifying each one:

1. Labels should be on White Background with Black Lettering. Ensure that the Text is large enough for easy identification from few feet.
2. Affix the Label to the Mounting Bracket in a Prominent Location, avoiding overlap on Manufacturer Label.
3. Label each Luminaire with Luminaire Number as indicated on Project Installation Drawings.

Making Electrical Connections

Wiring: Branch Power Circuits feeding AEON™ LED Luminaire shall be 120-277V or 277-480V AC Only.

Warning: NEVER connect AEON™ LED Luminaire to Nominal Voltage above 480VAC. The Voltage on the Lighting Circuits must stay within 3% of nominal at 60Hz. Voltage that is consistently too high or low shall be corrected before LED luminaires are installed. Failure to Follow these Warnings may lead to Luminaire Damage and/or Failure and will Void All Warranties.



Warning: NEVER Connect the Luminaire to an Electrical System that is not Grounded. Installing a Luminaire in an Ungrounded Electrical System could allow the Housing to become Energized in the event of an Electrical Short, resulting in the Risk of Electrical Shock for anyone who comes into contact with the Luminaire. Failure to Follow these Warnings May Lead to Severe Injury, Property Damage or even Death.

Fusing: If Individual Branch Circuit Protection is required, the Table below shows the Minimum Fuse Ratings (MFR) for each Individually Circuited Luminaire.

AEON™ Model	100-277V MFR	277-480V MFR
500W	300V, 7 Amps.	300V, 3 Amps.
750W	300V, 9 Amps.	300V, 4 Amps.



Warning: Failure to Wire the Luminaire properly as suggested above can cause Permanent Damage to the Luminaire and/or can cause Physical Harm and even Death. Installation should only be performed by a Qualified and/or a Licensed Electrician.

Wiring Connections:

Warning: Failure to Follow these Warnings May Lead to Severe Injury, Property Damage, or even Death. In order to Prevent or Create the Risk of Electrical Shock:

- The Ground Leads Must Always be Connected Before any other Leads.
- NEVER connect the Bare or Green Insulated Ground Wire to the Black (LIVE/HOT) Current-Carrying or White (NEUTRAL) Supply Wire, as this could Energize the Housing and Create the Risk of an Electrical Shock.
- DO NOT Damage or Cut the Wire Insulation during Installation.
- DO NOT Mount or Support this Luminaire in a manner that can Cut the Outer Jacket or Damage Wire Insulation. Make sure all Connections are Secure using only approved Connecting Devices.
- DO NOT Expose Wiring to Edges of Sheet Metal or other Sharp Objects.
- DO NOT Make, Alter, Relocate or Remove Wiring, Power Supply or any other Electrical Component.
- DO NOT Make or Alter any Open Holes in an Enclosure of Wiring or Electrical Components during Installation.



Power Input:

High Voltage (277-480VAC): All AEON™ LED Luminaires come with a Sheathed SOOW/SOW Style 3C Cable with 18AWG, 600V annealed stranded bare copper per ASTM B-174 with temperature range of -40°F to +221°F (-40°C to +105°C).

Low Voltage (120-277VAC): All AEON™ LED Luminaires come with a Sheathed SJOW Style 3C Cable with 18AWG, 300V annealed stranded bare copper per ASTM B-174 with a minimum temperature range of -40°F to +221°F (-40°C to +105°C).

Dimmable Cable Assembly: AWM Style 22AWG, 105°C, 300V, VW-1.

AEON™ Cable Assembly is Weather-Resistant, UV Stabilized, and certified for Indoor and Outdoor use. Any additional Cables used to connect to the Luminaire must strictly match these Specifications.

Power Input: Connect the Luminaire Power Whip to Incoming Power Wires or the Plug. See the Table below for the Correct Color Designation:

Luminaire Power Wire	Color Designation	Luminaire Dimming Wire	Color Designation
Black	Line (Live)	Purple	(+) Anode
White	Neutral	Gray	(-) Cathode
Green	Ground	Auxiliary Source Wire	Black & White

Dimming: The AEON™ LED Luminaire is Capable of Dimming with a 3 Conductor Colored Cable. The Output Wire is Standard AWM Style 22AWG, 105°C, 300V, VW-1, to connect to the Dimming Cable - Purple Connects to DIM (+) and Gray Wire Connects to DIM (-).

0-10VDC Dimming Mode: Dimming is controlled by means of a 0-10VDC Signal (to be provided by the Installer) to Control the Level of Dimming. At 10 Volts, the Output of the Unit is 100%; at 0 Volts, it will TURN-OFF. 120-277V may dim down to 10%. The DC Dimming Voltage should never exceed 15 VDC. Increasing the Voltage from 10VDC to 15VDC will not result in additional Light Output.

Note: When Power is TURNED-ON, the Luminaire defaults to 100% on unless Dimming Mode is used or a Different Control Signal is present.

Important Notes:

- The Low Voltage Dimming Wires are connected to the Grounded Output Section of the Driver inside the Luminaire.
- Never Connect either one to the Hot or Neutral Supply Wires.
- Purple Connects to DIM (+) and Gray Wire Connects to DIM (-)
- Auxiliary Source Wire (Unattached/Open) is Black & White

Variable Voltage Control: An Analog 0-10V Active Dimmer may be connected to the Two Wires to Control the Light Output of the Luminaire. Multiple Luminaires may be connected to the same Dimmer, as long as the Maximum Current Rating of the Dimmer is not exceeded.

The Dimmer must be Capable of Sinking 0.5mA per Luminaire. Light Output will vary approximately linearly with Control Voltage, with 10V corresponding to 100% Light Output.

Aeon Color Coded Quick Connect Wiring

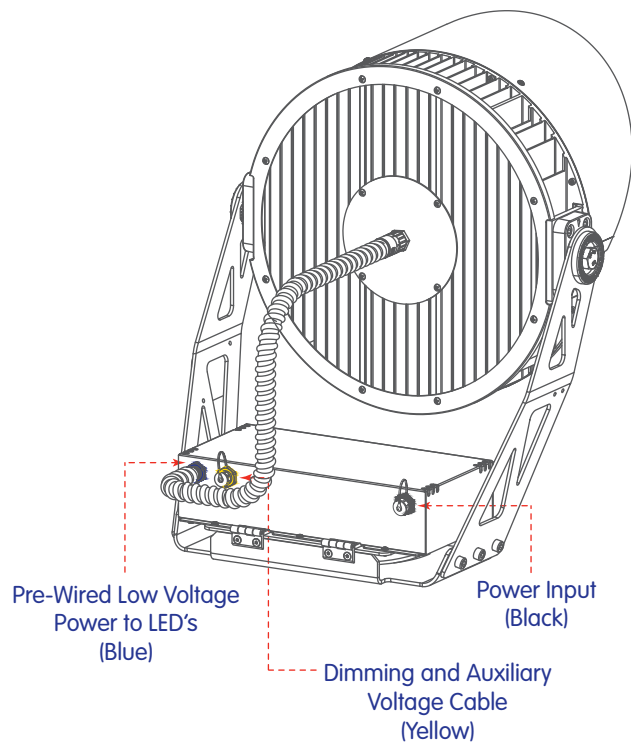

Wireless Lighting Controller

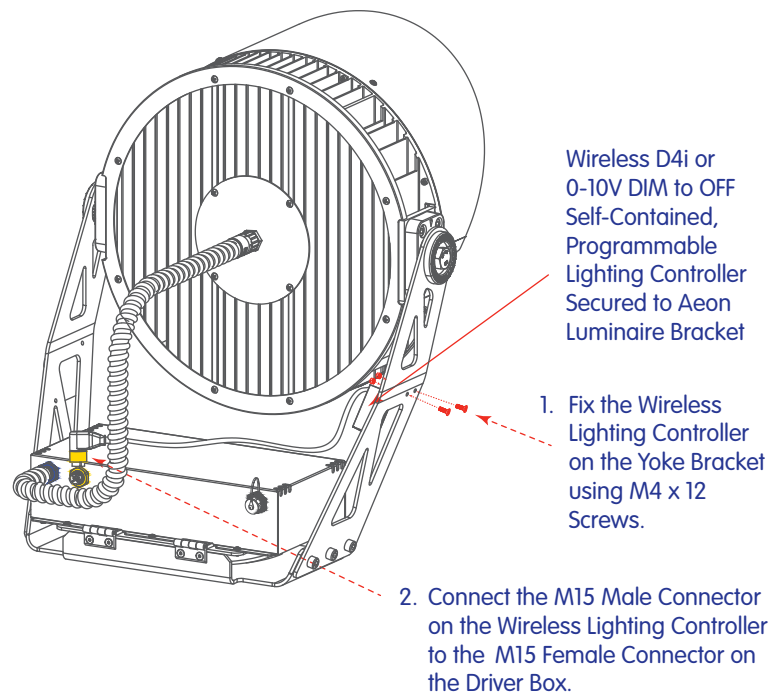

Cable Connector Types



3-Pin Power Input Cable Connector (Black)



3-Pin Dimming with 12V Auxiliary Source Voltage Input Cable Connector (Yellow)



2-Pin Driver Power Output Cable Connector (Blue)

Important Note: Please check Wire Orientation when Plugging-In to avoid any damage to the Cable or the Connectors.

Wiring Diagrams

SINGLE PHASE, 120V & 277V - WIRING DIAGRAM

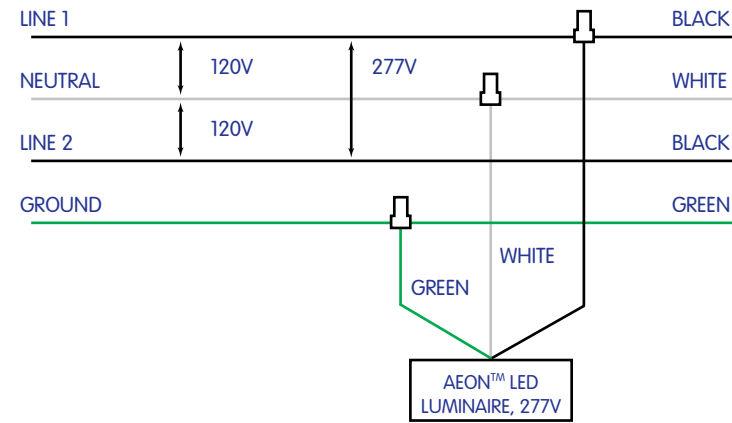

SINGLE PHASE, 240V - WIRING DIAGRAM

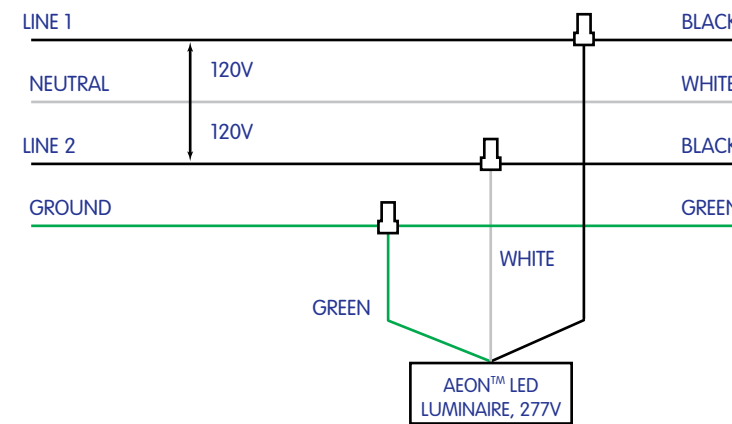

SINGLE PHASE, 277V & 480V - WIRING DIAGRAM

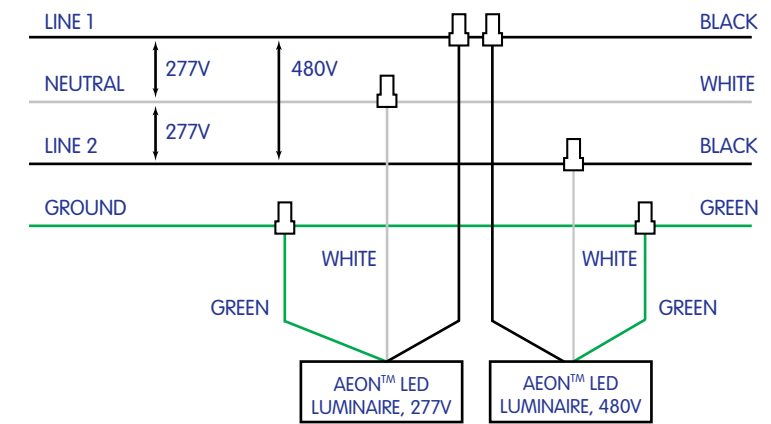

THREE PHASE, 277V & 480V - WIRING DIAGRAM

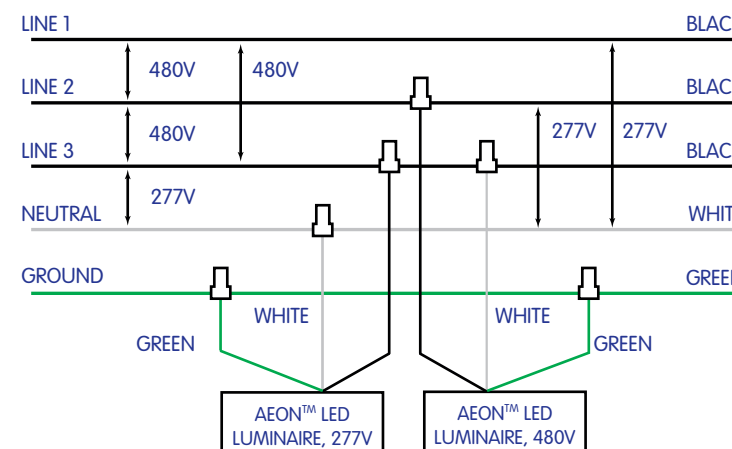

THREE PHASE, 480V - WIRING DIAGRAM

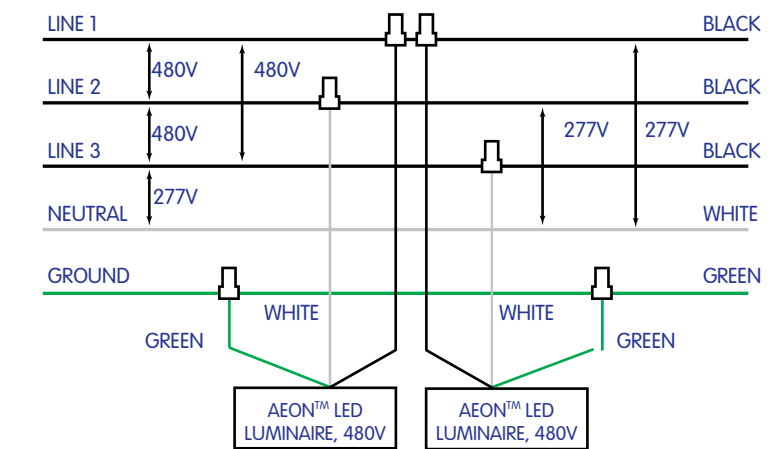

WARNING: Install this Luminaire where the Power Supply Voltage to the Luminaire **does not exceed** as specified on the AEON™ LED Luminaire.

Verify using Multimeter that Power Supply Wiring Voltage matches Supply Voltage by comparing it with the Power Supply Label. Improper Power Supply Voltage matching to the Luminaire can result in Physical Damage and/or Performance Degradation.

WARNING: Dangerous Voltages Exist within the Unit and all Precautions in Handling High Voltage Equipment should be Strictly Observed when replacing the Light Engine or otherwise Servicing the Luminaire. Disregarding this Warning could result in Electrical Shock and Severe Injury, Property Damage or even Death to the Individual Installing or Servicing this Luminaire.

AEON™ will not accept any Responsibility for Injury, Damage, or Loss which may occur due to Improper or Careless Handling, Incorrect Installation, Operation, or Maintenance of its Products.

DIMMING
WIRING DIAGRAM

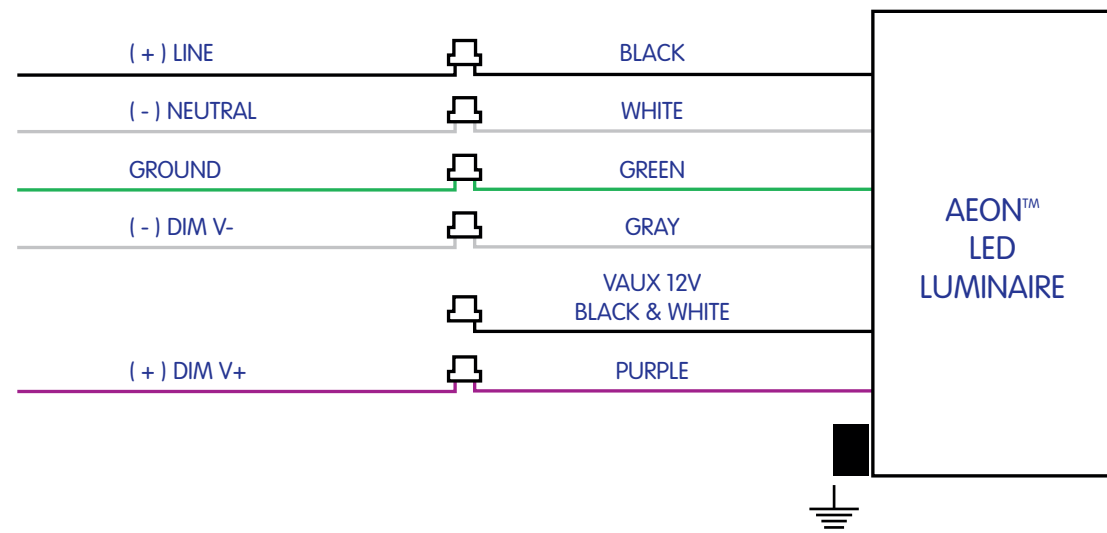

PHOTO-CONTROL
WIRING DIAGRAM
3-PIN

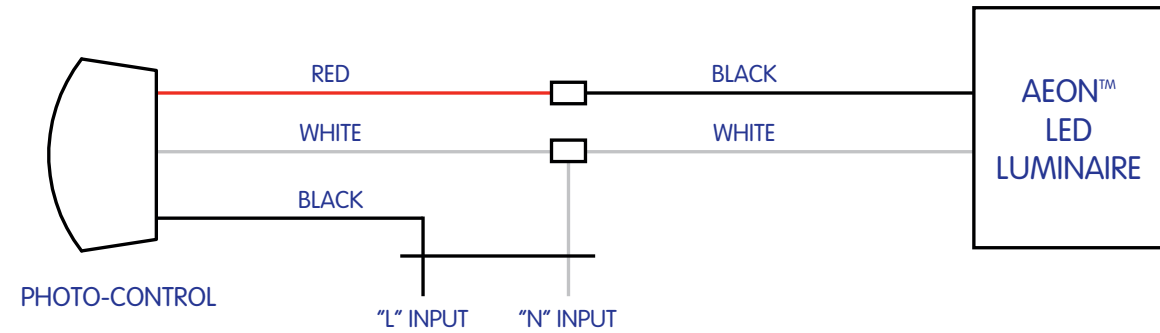

PHOTO-CONTROL
WIRING DIAGRAM
5-PIN

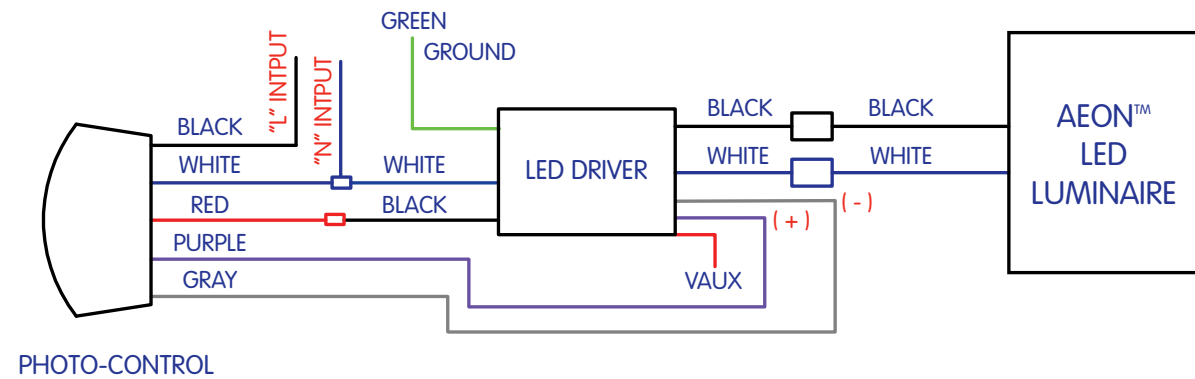
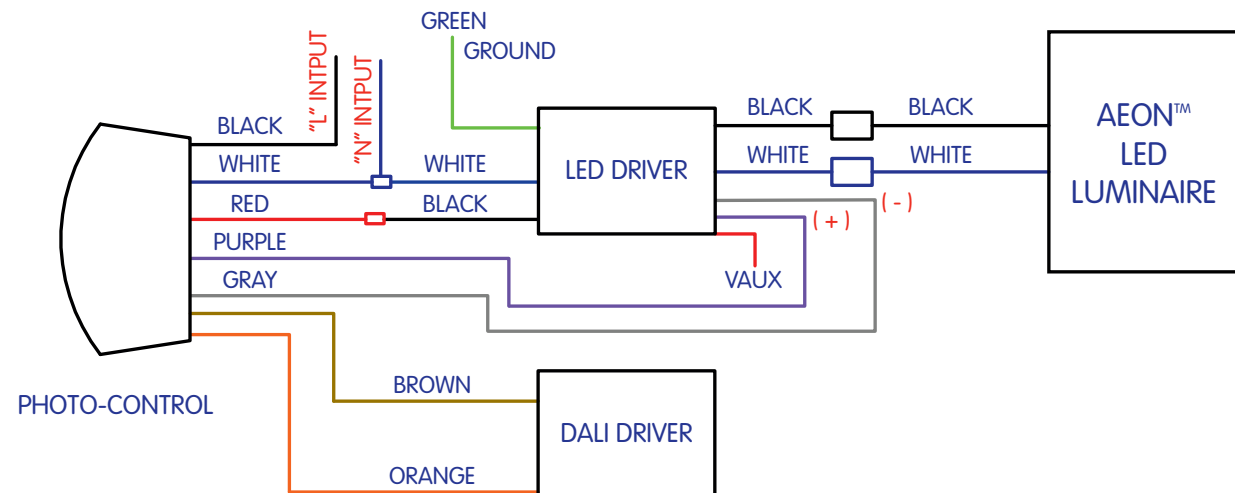

PHOTO-CONTROL
WIRING DIAGRAM
7-PIN



Aiming: AEON™ LED Luminaire can be Mounted in any Direction, at any Angle.
Please refer to the Aeon Tilt and Orient Angles Diagrams on Page 6, 8, and 12.

Aim the Luminaires: Aiming the Luminaires is an Important and a Critical Part of the LED Lighting Solution to ensure that the Light is evenly distributed on to the Surface. For properly aiming a Sports Venue, there are Two Basic Methods used: Precision Laser Aiming by Coordinates and Orient-Tilt.

1. Precision Laser Aiming by Coordinates: Laser Aiming is the most Effective and Preferred Technique for aiming AEON™ LED Sports Luminaire. This method uses a Laser, mounted to the Luminaire to point the Luminaire at a Pre-determined Point on the Playing Surface using (X, Y) Coordinates. Unless otherwise noted, aiming Coordinates on Project Installation Drawings are based on the Origin (0, 0, 0) placed at Center Field, Court, or Ice. For Baseball Fields, Origin is usually the back point of Home Plate. All Dimensions from that Point are in Feet along the Playing Surface, unless otherwise noted.

2. Orient-Tilt: With the Orient-Tilt method, the Installer turns the Luminaire according to Pre-determined Angles. This technique is extremely helpful for Pre-aiming Luminaires mounted on a Cross-arm on the Ground before the Lighting Pole is Lifted-up and Set-in-place. However, this method is less Accurate due to the Variances in actual Final Pole and Luminaire Locations and Orientations compared to the approximated Parameters used in the Photometric Design.

a. Orient Angle: Refers to the Direction the Luminaire faces in the Z-Plane. Mount the Luminaire to the Structure but leave the Mounting Nut slightly loosened to allow the entire Luminaire to Spin about the Mounting Bolt. Set the Luminaire Orient by Rotating the Luminaire Mounting Bracket relative to the Mounting Structure.

Unless otherwise noted, Orient values shown on AEON™ Photometrics or Project Installation Drawings are based on 0° being Plan East. Plan East means 0° is heading to the right side of the sheet as you hold it in front of you, which is not necessarily geodetic or True East.

b. Tilt Angle: Refers to the Direction the Luminaire faces in the Y-plane. When the Luminaire is Securely Mounted to the Structure so that the Mounting Bracket does not move but the side Hex and Set Screws are loosened, the Luminaire may Rotate-up inside the Mounting Bracket. Set the Luminaire Tilt Angle by Rotating the Luminaire Housing relative to the Luminaire Mounting Bracket.

Minimum Tilt Angles: The side set screws will not allow the Stadium to be tilted downward at an angle of more than 45° relative to the Horizontal Axis. If the Luminaire must be tilted down at an angle greater than 45° from the Horizontal, remove the side Set Screws. If the Luminaire must be aimed down at less than 15° tilt relative to the Vertical Axis, use the Inverted Mounting Configuration.

Final Aiming: Aiming information is exported from Computer Lighting Simulation Software. Since on Site Conditions may vary from the Computer Models, Final Aiming is usually required to fully achieve Desired Lighting Specifications. Final Aiming means deviating from designed Aiming Parameters to produce the best outcome on the Playing Surface. Typically, Final Aiming only requires Slight Adjustments.

1. Verify that all Lights are Correctly Aimed according to the Photometric or Installation Drawings.
2. Measure Light Levels on the Playing Surface with a Calibrated Light Meter. Unless otherwise noted, take readings at 3 ft. (1M) above Ground, holding the Meter out at Arm's length as much as possible, thereby reducing the effect of the Shadow from your Body.

Note: Take Horizontal Readings by holding the Meter Face-Up, Parallel with the Ground. Take Vertical Foot-Candle Readings by facing the Meter at a Perpendicular Angle to the Floor toward the Vertical Main or Vertical End-Point. These vary based on Venue And Sport, but basically refer to the typical Locations for Elevated Main Cameras, at the Center Lines directly off of the side and off of the end of the Playing Surface.

Refer to Specific Project Requirements or Governing League Regulations for more information. For reference, the NCAA lighting Best Practices website has Grid Layouts by Sport: <http://www.ncaa.com/news/ncaa/article/2013-11-21/ncaa-best-lighting-practices/>

3. Review the Light Measurements and compare the data to Project Requirements or Photometric Drawings. If the Light Measurements do not meet Designed Levels, Final Aiming is required.

Note: There is no hard and fast rule on how to make Final Aiming Adjustments as it is essentially an art form due to the Propagation and Reflection Properties of Light. A Bright Spot is usually not caused by one Individual Luminaire but rather the additive effect from Several Luminaires aimed in the same General Vicinity.

4. Note the Areas of the Playing Surface that are the Brightest and Darkest and determine which Luminaires are aimed toward the Bright Areas and which are Aimed near the Darkest Areas.

5. Re-aim One or a Few Lights away from the Bright Areas and Closer to the Darker Areas.

WARNING: During Final Re-aiming, always Minimize the Number and Size of Aiming Modifications. Make just One or a Few Small Adjustments and then Re-check Light Levels. Making too many Significant Aiming Changes may result in Failure to Meet Specified Levels or introducing unwanted results.

6. Re-measure Light Levels in areas where Adjustments were made and compare new results to Project Specifications.

7. Repeat Steps 5-6 as necessary to meet Light Level Requirements.

To complete the Installation, verify that all Mounting, Connections, and Aiming work is finished.

- Verify all Electrical Connections are Tight and Secured. The Installer is Responsible for the Integrity of all the Connections.
- Verify all Bolts and Screws are Tightened and Properly Torqued.
- Straighten up all Cabling. Tie down all Cables neatly. For all outdoor projects, use UV rated tie-wraps and Cable Management.

Note: When Power is turned ON, the Luminaire defaults to 100% on unless a Different Control Signal is present.

Laser Aiming

Warning: Never point the Aiming Laser at any person or animal as it can cause Permanent Damage to Eyes. Use the Laser only for aiming Luminaire(s) as directed. Failure to heed this Warning May Lead to Severe and/or Permanent Injury.

1. Line up the Laser Pointer (Included) with the Aiming Mount

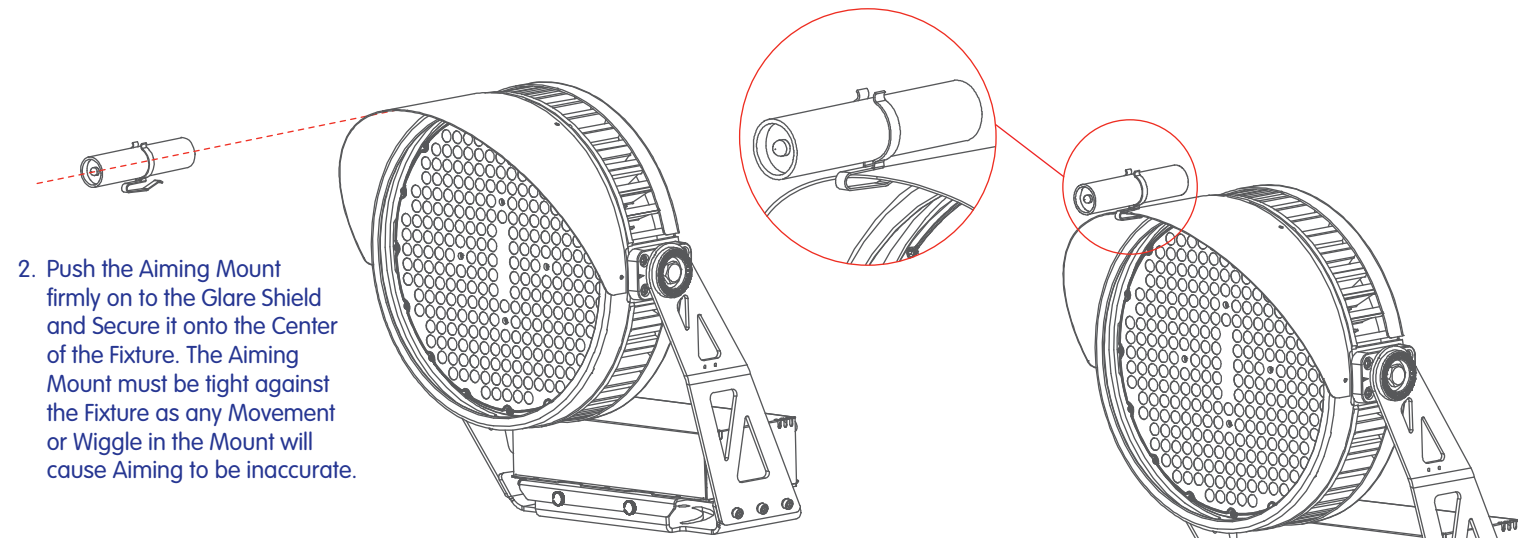

2. Push the Aiming Mount firmly on to the Glare Shield and Secure it onto the Center of the Fixture. The Aiming Mount must be tight against the Fixture as any Movement or Wiggle in the Mount will cause Aiming to be inaccurate.

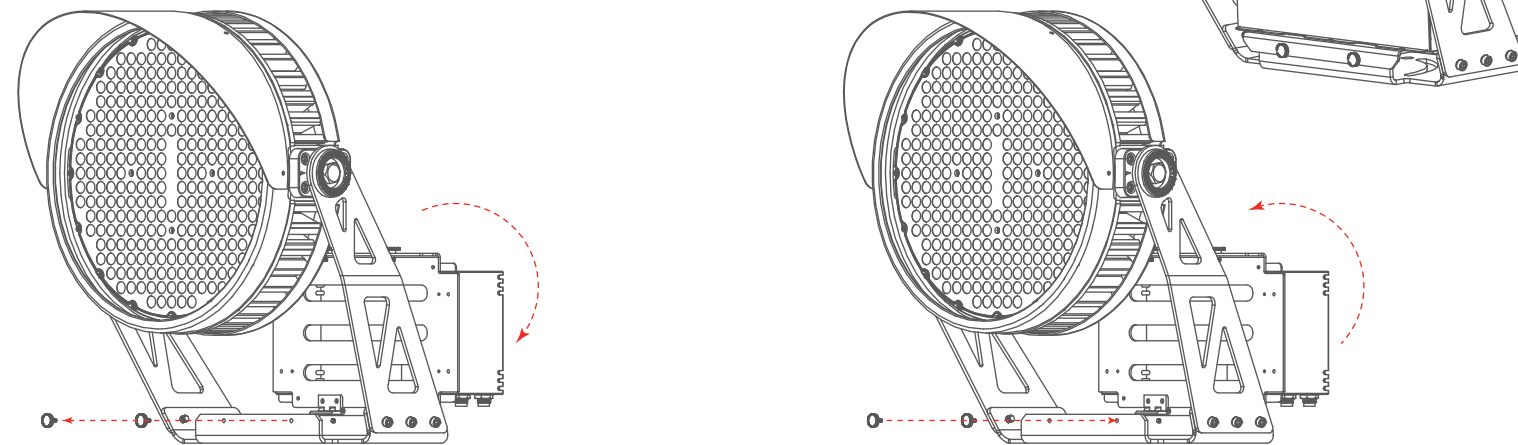

3. Remove 2 Knobs from the Front Side of the Driver Box and Flip it Upwards.

4. Slightly loosen the Fixture Bolts and Screws just enough to allow the Fixture to Rotate and Tilt.

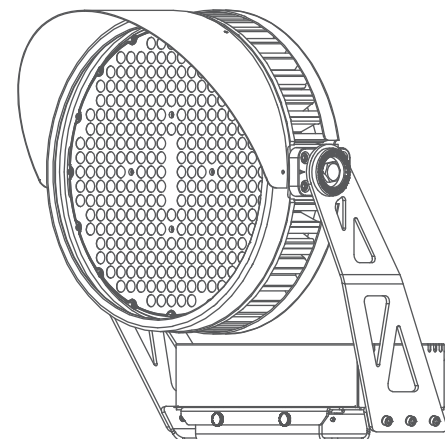

5. Turn on the Laser and Aim the Fixture by targeting the Laser Dot at the Aiming Point. If an Aiming Tube is used, look through Tube and adjust Fixture until Aiming Point is Centered in view through the Tube. Refer to Photometrics or Project Installation Drawings for Aiming Point Coordinates. Note: After targeting the Aiming Point with the Laser, turn-off the Laser to Conserve Battery Life.

6. After Aiming is complete, Tighten all Bolts and Screws including Hex and Set Screws on Side of the Fixture and Mounting Hardware.

7. Briefly turn the Laser back on to Verify that the Luminaire Aim did not Shift during tightening the Bolts and Screws.

8. Flip the Driver Box Downwards and install the 2 Knobs on the Front Side of the Driver Box. Hand tighten both the Knobs so that the Driver Box is Secure.

9. Remove the Laser Mount from the Fixture and proceed to the next Luminaire.

Caution: Turn-off Laser while not in use to Conserve Battery. Have spare Battery charged to facilitate the Aiming Process.

Maintenance: Proper care of the Luminaires will Maintain their Performance and Appearance. Follow a Regular Maintenance Schedule to retain Optimal Light Output and Thermal Performance. Remove any Dirt, Leaves and Other Foreign Debris from the Luminaire housing. Wipe the Optical Lenses with a Clean, Dry, Cloth to remove Dust and other Contaminants.

• **WARNING - Risk of Electric Shock:** Dangerous Voltages Exist within the Unit and all Precautions in Handling High Voltage Equipment should be Strictly Observed when Servicing the Luminaire. All Servicing should be performed by a Certified Licensed Electrician. Turn-off Power before performing any Electrical or Control Work. **Disregarding this Warning could result in Electrical Shock and Severe Injury, Property Damage, or even Death to the Individual Installing or Servicing this Luminaire.**

• To avoid Personal Injury, make certain Power is OFF before attempting any Inspections, Servicing, Maintenance or Removal.

• DO NOT make or alter any open holes in the Luminaire. Do not modify the Luminaire.

• Due to the possibility of High Temperatures, avoid Touching any External Surface of the Luminaire until the Unit Cools Down.

• To avoid Possible Damage to the Eyes, make certain that the Luminaire is OFF.

• Do not set the Luminaire on the Lens.

• Electrostatic Discharge (ESD): ESD can damage LED Luminaires. Personal Grounding Equipment must be Worn during all Servicing of the Unit. DO NOT Touch Individual Electrical Components as this can cause ESD, Shorten Lamp Life, or Alter Performance.

Notice: Risk of Product Damage: Failure to Strictly Follow all Instructions could Result in Damage to the Product and Void ALL Warranties!

Perform Visual, Mechanical, and Electrical Inspections on a Regular Basis. To keep Maximum Luminaire Efficiency AEON™ recommends checks to be made minimum on a yearly basis. Frequency of Use and Environmental Conditions, however should Determine the Frequency of Inspections. It is recommended to follow an Electrical Preventive Maintenance Program as described in NFPA 70B: Recommended Practice for Electrical Equipment.

Cleaning: Inspect the Luminaire to ensure that they are Free of any Obstructions or Contamination (i.e. Excessive Dust Build-up). Clean with a Non-abrasive Cloth, if needed. The Lenses should be Cleaned Periodically, as needed, to ensure continued Photometric Performance. Clean the Lens with a Soft, Damp, Non-Abrasive, and Lint-free Cloth. If not sufficient, Use a Mild, Non-abrasive, Non-Corrosive Detergent or an Ammonia-Free Liquid Cleaner of Neutral pH (pH approximately 6 to 8), which contains no Chlorinated or Aromatic Hydrocarbons. Do not use and Abrasive, Strong Alkaline, or Acid Cleaners as damage will certainly occur.

Immediately after Cleaning the Luminaire, Rinse with Clear, Clean, Cold Water to remove all Soap Residues and Wipe Dry with a Clean, Non-abrasive Soft Cloth. Rinse with Clean, Cold Water and Wipe Dry. There is no need to Clean the inside of the Luminaire with Soap and Water. However, it is recommended to remove Dust, Cobwebs, Nests or Active Insect Infestations, or any other things that might interfere with the Proper Functioning of the Luminaire.

Cleaning Instructions:

• It will occasionally be necessary to Clean the outside of the Lens. Frequency of Cleaning will depend on Ambient Dirt Level and Minimum Light Output which is acceptable to the user.

• Lens should be wiped with a DAMP Cloth with a Solution of Warm Water and a Mild, Non-Abrasive Household Detergent. Dry with Soft, Dry, Clean Cloth.

• Do NOT use Chemical Cleaners such as Powder Cleansers, Bleach, etc. Do not use Scouring Pads, as this will Scratch and Damage the Lens Finish.

• Do NOT Wipe with a Soiled Cloth or Wet Towel - these may leave a Residue that can Damage Finish.

• Do NOT use any abrasives such as Car Wax, Brass Cleaners or Other Polishes Or Chemicals. These may Scratch, Remove, or Damage the Protective Coating, allowing Moisture and Pollutants to come into contact with the Luminaire Body, possibly Discoloring or Pitting the Finish.

Troubleshooting

WARNING: Before performing any work on the Luminaire, shut off the power circuit, verify the power is off with a Multimeter, and wait a couple of minutes before handling the Luminaire to avoid Electrical Shock. Failure to Follow this Warning could result in Severe Injury, Property Damage or even Death to the Individual Installing or Servicing this Luminaire.

Symptom	Possible Cause	Corrective Action
No Light Output	Power is OFF	Check if Circuit Power is ON
	Bad Wire Connection	Check Input Wiring Connections
	Control Signal Set to 0	Verify Control Signal
Fuse Blows or Circuit Breaker Trips	Crossed Wires or a Supply Wire is Grounding Out	Check Wiring Connections
	Improperly Sized Fuse or Breaker	Refer to Minimum Fuse Ratings

This device complies with Part 15 of the FCC Rules. Operation is subject to the following two conditions: (1) This device may not cause harmful interference, and (2) this device must accept any interference received, including interference that may cause undesired operation.

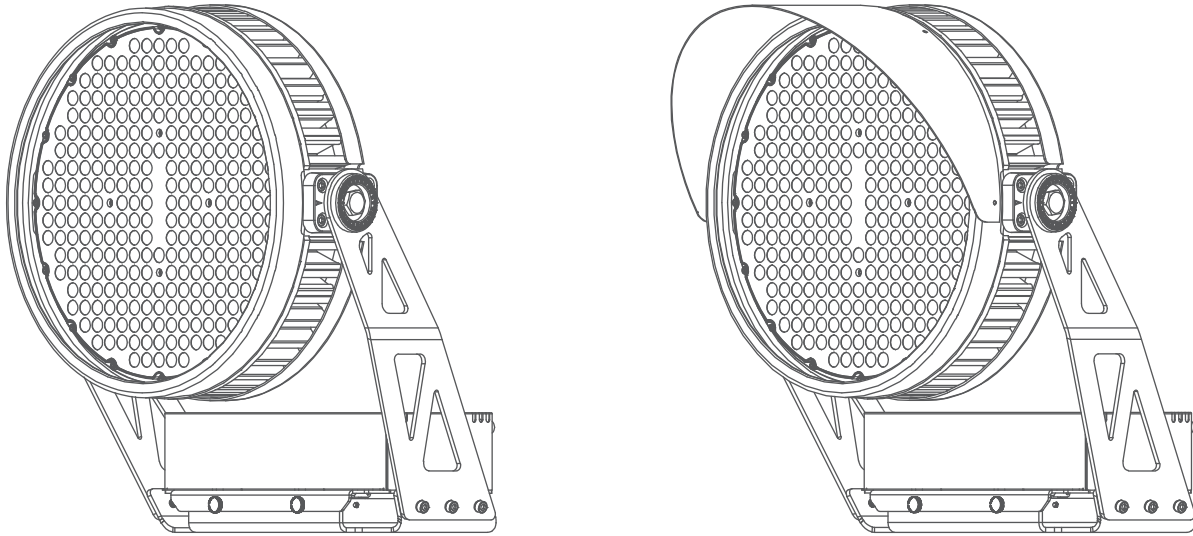

NO
LEAD, MERCURY,
HEAVY METALS
OR TOXIC GASES

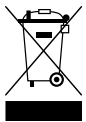

INFORMATION ON WASTE DISPOSAL FOR CONSUMERS OF ELECTRICAL & ELECTRONIC EQUIPMENT.

When this product has reached the end of its life it must be treated as Waste Electrical & Electronics Equipment (WEEE). Any WEEE marked products must not be mixed with General Household Waste, but kept separate for the Treatment, Recovery and Recycling of the Materials used. Contact your Local Authority for details of Recycling Schemes in your area.

Recycle: For information on how to recycle LED electronic products, please visit www.epa.gov.

As part of the Company's Continuous Product Improvement Program, HyLite LED, LLC. reserves the right to change materials or modify the design of its product without notification. All Specifications Subject to Change without notice. All values are Design and/or Typical Values when measured under laboratory conditions. Actual Values depend upon the Ambient Temperature of the Installation Location. Please consult Factory for your Specific Requirements.

All Statements, Technical Information, and Recommendations contained herein are based on Information and Tests that HyLite believes to be Reliable. The Accuracy or Completeness thereof is not Guaranteed. In accordance with HyLite "Terms and Conditions of Sale" and since Conditions of use are Outside our Control, the Purchaser should determine the Suitability of the Product for his or her Intended Use and assumes all Risk and Liability whatsoever in Connection therewith.

The customer is Responsible for Compliance with Local and National Safety Laws, Best Practice Codes, and Applicable Standards when installing Electrical Equipment and should ensure they adhere to the same.

Changes or Modifications not Expressly Approved by the Party Responsible for Compliance could Void the User's Authority to Operate the Equipment.

© 2020-2022 HyLite LED, LLC., USA. All Rights Reserved. Aeon and the Products described in it are Copyrighted by HyLite LED, LLC., USA, with All Rights Reserved. This User Manual may not be Copied in Whole or Part, without the Express Written Consent of HyLite LED, LLC., USA.

2025 Pay Rate

Doniphan-Trumbull

Head Wrestling Program

Head Boys 15.17% jumping to 18% next year

Head Girls 15.17% jumping to 18% next year

Head JH

Possibly adding assistant 10.25% max

Ord

Head Boys 9% to 18%

Assist. Boys 6.3% to 12.6%

Head Girls 9% to 18% 1-10 year exp.

Assist. Girls 6.3% to 12.6%

1 Jr. High 5% to 8.6%

Gibbon

Head Boys 13% Step one

Assist. Boys 11%

Head Girls 13% Step one

Assist. Girls 11%

2 Jr. High

Head Girls 4.50%

Assist. Girls 3%

Wood River

Head Boys 9% floor \$5500

Assist. Boys 5.60% floor \$2750

Head Girls 9% floor \$5500

2 Assist. Girls 5.60% floor \$2750

2 Jr. High 3% floor 2200

Central City

Head Boys 15.5% to 19.5%

Assist. Boys 9.75% to 13.75%

Head Girls 15.5% to 19.5%

JH Head Girls 5.25% to 9.25% looking to bump a coach or 2 as numbers increase

St. Paul

Head Boys
Assist. Boys
Head Girls
Assist. Girls
1 Jr. High

Centura

Head Boys	12% to 14.7%
Assist. Boys	8% to 10.7%
Head Girls	12% to 14.7%
Assist. Girls	8% to 10.7%
Jr. High Head	6% to 8.7%
Jr. High Assist.	4% to 6.7%

ALC

Head Boys	11% to 14%	Same coaches do boys and girls together
Assist. Boys	8% to 9.4%	
Head Girls	11% to 14%	
Assist. Girls	8% to 9.4%	
Jr. High Head	5.6% to 7%	
Jr. High Assist	5.6% to 7%	



Ravenna Girls Wrestling

2025-26 Schedule

(Dates are correct)

Day	Date	Opponent	Site	Time
Thursday	December 4-Wk 22	Quad w/ Centura, St. Paul, Gibbon	St. Paul	
Saturday	December 13-Wk 23	Wood River Invitational	Away	10:00 am
Thursday	December 18-Wk 24	Gibbon Invitational	Away	5:00 pm
Saturday	January 3 Wk 26	SEM Invitational	Sumner	10:00 am
Friday	January 9-Wk 27	Franklin Invitational	Away	3:00 pm
Friday	January 16-Wk 28	Ord Invitational	Away	1:00 pm
Saturday	January 17-Wk 28	Sandhills-Thedford Invitational	Sandhills	10:00 am
Saturday	January 24-Wk 29	LPC Tournament	Home	10:00 am
Saturday	January 31-Wk 30	Ansley Invitational	Ansley	9:30 am
Fri-Sat	February 6-7-Wk 31	District Tournament	TBA	TBA
Tues-Wed	February 17-18-Wk 33	State Wrestling Tournament	Omaha	TBA

2024- 2025 Secondary Principal Salary Array

School	Base Salary	Additional Compensation	Benefits	Total Years Experience	Principal Education				Total Compensation
Centura	\$111,000.00	\$6,120.00	\$50,250.00	18	Specialist				\$167,370.00
Gibbon	\$115,356.00	\$0.00	\$45,590.00	22	Specialist				\$160,946.00
Pleasanton	\$109,000.00	\$0.00	\$38,045.00	26	Masters				\$147,045.00
Wood River	\$119,600.00	\$0.00	\$25,853.00	19	Masters				\$145,453.00
Shelton	\$91,693.00	\$6,549.00	\$37,205.00	20	Masters				\$135,447.00
Ravenna	\$100,000.00	\$5,735.00	\$19,822.00	18	Masters				\$125,557.00
St. Paul	\$102,750.00	\$0.00	\$18,913.00	36	Masters				\$121,663.00
Loup City	\$98,000.00	\$3,120.00	\$44,882.00	22	Masters				\$146,002.00
Array Average:	\$105,924.88	\$2,690.50	\$30,205.50	23					\$143,685.38
Mean	\$105,924.88								\$143,685.38
Median	\$105,875.00								\$145,727.50
Midpoint	\$105,646.50								\$144,516.50
102% of Midpoint	\$107,759.43								\$147,406.83
100% of Midpoint	\$105,646.50								\$144,516.50
98% of Midpoint	\$103,533.57								\$141,626.17
Actual Percentage of Midpoint	94.66%								86.88%
Additional Compensation Required-102% of Midpoint	\$21,849.83								
Additional Compensation Required-100% of Midpoint	\$18,959.50								
Additional Compensation Required-98% of Midpoint	\$16,069.17								
Current Salary	\$100,000								\$141,626.17
Proposed Salary	\$116,069.17	\$5,735.00	\$19,822.00						\$141,626.17
Salary Increase to Get to 98% of the 98%-102% Comparability Array = \$16,069.17									

2024-25 S

School	Base Salary	Additional Compensation	Benefits
Gibbon	\$195,576.00		\$29,683.00
St. Paul	\$150,700.00		\$55,306.00
Ravenna	\$150,846.00		\$54,560.00
Centura	\$140,000.00	\$0.00	\$55,452.00

Pleasanton	\$145,000.00	\$0.00	\$41,643.00
Wood River	\$155,500.00		\$25,853.00
Loup City	\$147,087.00		\$37,176.00
Shelton	\$132,000.00		\$51,533.00

Amherst	\$126,500.00		\$28,046.00
---------	--------------	--	-------------

Array Average:	\$149,245.44		\$42,139.11

Superintendent Salary Array

Years of Experience	Education Level		Total Compensation	Rank
29	Doctorate		\$225,259.00	1
19	Specialist		\$206,006.00	4
27	Doctorate		\$205,406.00	3
14	Doctorate		\$195,452.00	7

27	Specialist		\$186,643.00	6
25	Specialist		\$181,353.00	2
30	Specialist		\$184,263.00	5
24	Doctorate		\$183,533.00	9

18	Specialist		\$154,546.00	8
----	------------	--	--------------	---

24	Mean		\$191,384.56	
	Median		\$186,643.00	
	102% of Midpoint	102%	\$192,794.05	
	Midpoint (100%)	100%	\$189,013.78	
	98% of Midpoint	98%	\$185,233.50	

Difference Between Current Compensation to Midpoint

102% = -\$12,611.95
 100% - Midpoint = -\$16,392.22
 98% = -\$20,172.50

Nebraska Department of Education
School Emergency Response Mapping Grant Awardees

School District/School Name:	Awarded Amount:
Adams Central Public Schools	\$11,535.00
Anselmo-Merna Public Schools	\$3,545.00
Arlington Public School	\$3,310.00
Ashland-Greenwood Public Schools	\$17,400.00
Auburn Public Schools	\$14,505.00
Aurora Public Schools	\$6,743.00
Bancroft-Rosalie Community Schools	\$11,691.00
Beatrice Public Schools	\$10,973.00
Bertrand Community Schools	\$3,797.00
Brady Public Schools	\$5,000.00
Cedar Bluffs Public Schools	\$5,370.00
Centura Public Schools	\$5,572.00
Christ Lincoln Schools	\$6,360.00
Christ Lincoln Schools, Yankee Hill Campus	\$4,835.00
Clarkson Public Schools	\$5,395.00
Columbus Christian	\$3,575.00
Creighton Community Schools	\$5,322.00
Cross County Community Schools	\$5,322.00
David City Public Schools	\$13,216.00
Deshler Public Schools	\$3,845.00
District #10, Elkhorn Public Schools	\$89,530.00
East Butler Public School District	\$9,119.00
Elm Creek Public Schools	\$3,875.00
Fillmore Central Public Schools	\$3,350.00
Freeman Public Schools	\$6,895.00
Gothenburg Public Schools	\$3,500.00
Hampton Public Schools	\$3,000.00
Hershey Public Schools	\$6,847.00
Holdrege Public Schools	\$12,135.00
Howells-Dodge Consolidated Public Schools	\$9,119.00

Humboldt-Table Rock-Steinauer School District	\$10,505.00
Humphrey Public Schools	\$13,216.00
Immanuel Lutheran School	\$4,898.00
Isanti Community Schools	\$3,797.00
Laurel-Concord-Coleridge Public Schools	\$7,594.00
Lincoln Christian School	\$4,835.00
Lincoln Lutheran Middle/High School	\$4,835.00
Loomis Public Schools	\$4,835.00
Lutheran High Northeast	\$3,797.00
Messiah Lutheran School	\$4,835.00
Norris School District 160	\$32,500.00
Osceola Public Schools	\$6,369.00
Perkins County Public Schools	\$9,000.00
Ravenna Public Schools	\$3,797.00
Sargent Public Schools	\$4,375.00
Shelton Public Schools	\$4,375.00
Southern School District	\$12,265.00
St Mark Lutheran School-Omaha	\$5,065.24
St. Bernard Catholic School	\$5,135.00
St. Edward Public Schools	\$3,797.00
St. Matthew Catholic School	\$3,986.85
St. Paul Lutheran School-Utica	\$3,797.00
St. Paul's Lutheran School- Beatrice	\$3,797.00
Summerland Public Schools	\$5,947.00
Sumner-Eddyville-Miller Public Schools	\$4,375.00
Thayer Central Community Schools	\$6,295.00
Tri County Public Schools	\$2,995.00
Trinity Lutheran School- Grand Island	\$6,360.00
Trinity Lutheran School- Lincoln	\$3,310.00
Twin River Public Schools	\$6,847.00
Wallace School District 65-R	\$5,322.00
Weeping Water Public Schools	\$6,895.00
West Point Public Schools	\$5,882.00
Wilcox-Hildreth Public Schools	\$4,056.33
Zion Classical Academy (Hastings)	\$5,747.76
Zion Lutheran School - Pierce	\$3,797.00



Nebraska Department of Education 2025 School Emergency Response Mapping Grant

Appendix A

Congratulations to the schools or districts awarded funds from the 2025 School Emergency Mapping Grant! Funding should be used to support the allowable use approved in the grant using the approved vendor listed in the application. Expenses must be new and cannot replace existing or budgeted state or local government funding. Moreover, expenses must directly relate to the purchase of site-specific mapping data, used to enhance security, and increase situational awareness for first responders. No funds were awarded to support multi-year subscription services. Please refer to the deadlines and steps below for this grant. If you have any questions or are submitting documentation or reimbursement requests for this grant, please reach out to Ellen D'Amore via email at ellen.d'amore@nebraska.gov and cc jay.martin@nebraska.gov.

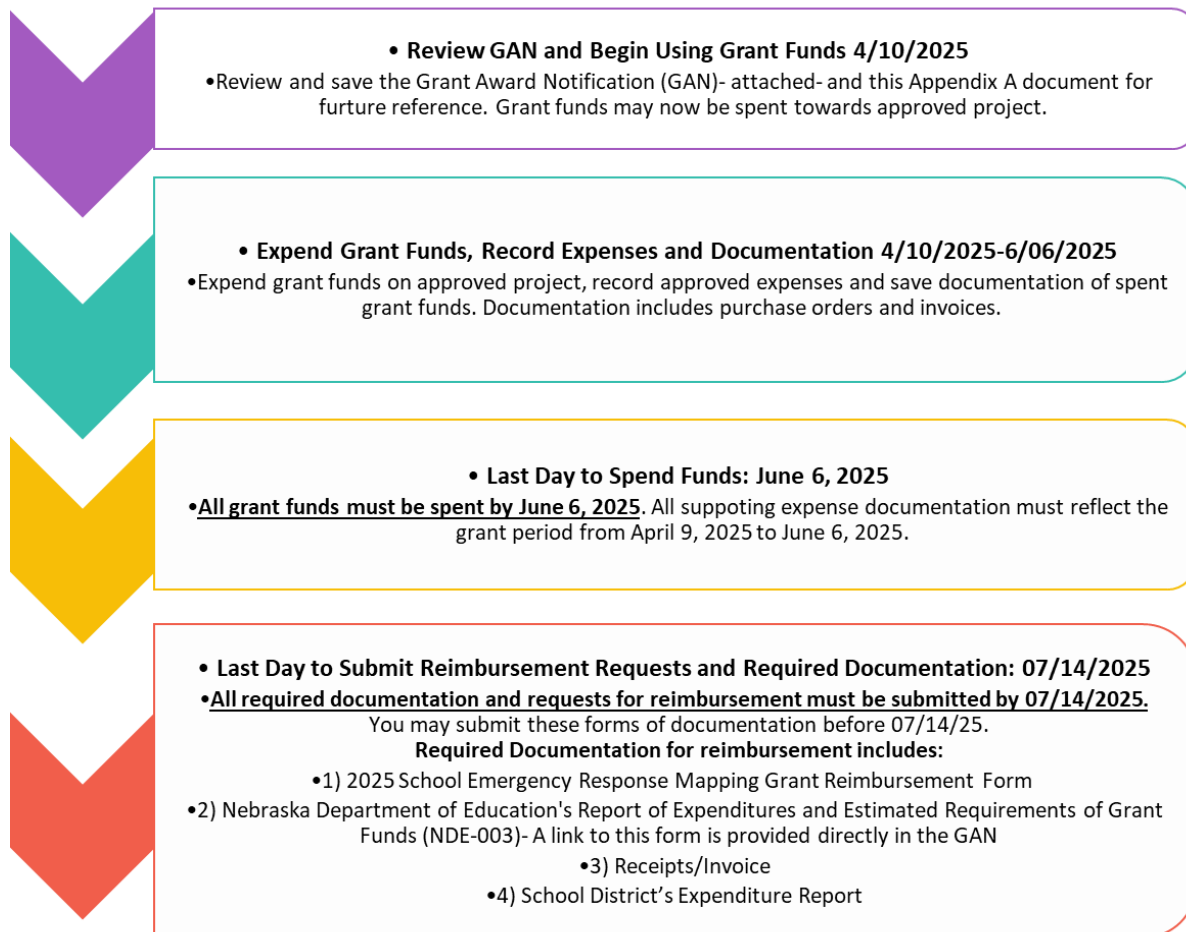

- L. The grantee will permit the Department and its auditors to have access to the grantee's records and financial statements as necessary for the Department to meet the requirements of the Uniform Grants Guidance located at 2 CFR 200.
- M. Total funding is contingent upon availability of appropriated funds.
- N. Additional terms and conditions are attached, if applicable.

NDE Approvals

Approved by:

Approved by:

Jay Martin
Jay Martin (Apr 10, 2025 11:14 CDT)

Zahid Uda
Zahid Uda (Apr 10, 2025 13:59 CDT)

AMERICAN FENCE COMPANY

Omaha · Lincoln · Grand Island · Sioux City · Des Moines · Cedar Rapids · Sioux Falls · Rochester
AmeriFence Corporation – Kansas City · AmeriFence Corporation – Madison · American Security & Gate Company – Fargo

FENCING & GATE PROPOSAL

Date: 10.31.24	
Attn: ESTIMATING DEPARTMENT	
Project: Ravenna Public School	
Project Address: 41750 Carthage Rd, Ravenna, Ne 68869	
Scope: American Fence Company to install 1,111/LF of 6' tall galvanized chain link fence. Line posts to be 2" OD. Gate and terminal posts to be 3" OD. Middle bracing at every end and corner post. All posts to be set using wet concrete mix. Included (2) 5' wide walk gates and (1) 8' double drive gate. All gate hardware included. \$28,755.06	
Price for 940/LF of fence. \$24,973.77	
No Tax Included in bid.	
Addenda: N/A	
Plan Sheets: N/A	Details: N/A
Spec Sheets: N/A	

Project Specific Notes:
1.
2. Only the scope and qtys listed above are covered under this quote; anything outside of this will need to be quoted before accepted.
3. No rocks excavation is included. If it's required, it will be charged at that time in a change order.
4. No removals of stumps, brush, rocks, trees or other obstructions that may interfere with our scope are included. Install locations must be clear of all debris before work commences. This includes any hole filling from this debris.
5. If special-order material applies, it cannot be paid on a per unit basis.
6. No permits, bonds, dues, completed operations, professional liability insurance or primary noncontributory is included unless noted in the scope above.
Start Date: Allow two – four weeks for submittals. Once approved, the material will be ordered within ten business days. Lead times can vary; request lead time of materials at time of submittal request.
Crew Size: 2-4 depending on available work.
<i>Notes are specific to the scope and directly impact project pricing. If not agreeable, advise prior to acceptance.</i>

Project Pricing: Look above for price breakdown.
<i>Unless otherwise stated, pricing does not include excise tax, subject to change after 30 days of date of proposal. This proposal is not binding unless signature is affixed to page two. Do not sign and return this sheet without signed second page. A purchase order initiates your project engineering process and holds your material pricing for 30 days. If American Fence Company does not receive approval to proceed with purchasing within this 30-day period, project pricing is subject to review.</i>

Contact Information: Brandon Goodenow C: 308-267-4772

EMAIL: b.goodenow@americafence.com

Standard Notes & Exclusions: Unless otherwise noted:
1. One mobilization is included for the installation of the fence.
2. Block-out(s) in concrete / masonry for fence by others. No core drilling included. Sleeves required but not provided by AFC.
3. No surveying and/or staking included. Fence line to be staked by others.
4. Private utilities to be located by others in accordance with the State’s One Call System standards. In the event these utilities are damaged as a result of improper location, AFC will not be responsible for damages and associated costs.
5. Fence line to be staked clear of utilities. No excavation included for digging within 18” of utilities but at additional expense. Hand excavation due to interference with utilities at \$35.00 per post hole.
6. No permits, bonds, dues, completed operations, or primary-noncontributory included.
7. No project specific employee background, drug screen or DMV history included. Add \$65.00 per employee if required.
8. No removals, grading, grubbing, and/or demolition are included.
9. No electrical wire, wiring, grounding, conduit, connections, and/or initial electrical/controls set-up. Only after electrician has confirmed connections and operations, AFC will review installation.
10. AFC will not be subject to liquidated damages or back charges as a result of delays.
11. Material fabricated per plans. No field verification, engineering, delegated design included.
12. Accounts not paid within thirty days will be charged eighteen percent (18%) per annum. No retention to be withheld.
13. No prevailing, union or Davis – Bacon wages included.
14. No participation in billing processing programs, Textura. Participation fee to be added to contract if required.

REV 03-06-19

Terms and Conditions

By signing this proposal, the customer has completely reviewed and agreed with the prices, specifications and conditions as stated herein. Furthermore, the customer is authorizing American Fence Corporation to complete the work. Unless stated, the fence does not include a warranty. The customer is financially responsible for cancellation fees and costs of special-order materials if the customer elects to cancel the contract. TERMS: 60% Down. Balance due on date of completion. No retention to be withheld. If withheld without approval, the contract amount will be 5% more than what is shown in the proposal. Service and handling charge of 1.5% per month-18% per annum applies to delinquent accounts not paid within 5 days of completion. Customer assumes full responsibility for location of property pins, staking of fence, and inaccurately placed pins and stakes. Customer understands that American Fence Company may stake the fence based on the proposal and/or in consideration of existing utilities that do not reflect the actual location of customer's property. Customer agrees to defend, hold harmless and indemnify American Fence Company against claims, liabilities and expenses for trespass and damage arising out of location of said fence. Customer assumes full responsibility for damage to marked and unmarked underground utility, telephone, T.V., cable or sprinkler systems. Customer requests, agrees or allows American Fence to locate the fence within 18 inches of any buried utilities; customer agrees to defend, hold harmless and indemnify American Fence Company against all claims, liabilities and expenses as a result of damage to these utilities and property. If the contract price is not paid when due, customer agrees to allow American Fence Company to trespass on to their property and remove fence at the company’s discretion. Furthermore, customer agrees to indemnify and hold harmless American Fence Company for any damage done to the property as a result of removal of the fence. All modifications shall be in writing and shall be affixed to the original bid. This agreement and subsequent modifications shall be contingent upon strikes, accidents, shortages or delays beyond the control of American Fence Company. Time stated for installation is purely estimated. The customer agrees and accepts that AFC will not extend discounts or credits for any delays or be held responsible for interest charges on any payments made by the customer. Changes to the fence due to varying ground conditions are not the responsibility of American Fence Company. Customer to carry fire, tornado and other necessary insurance. This proposal cannot be withdrawn by the customer after acceptance of proposal. American Fence Company has the right to reject any bid. Legal and related fees accrued to collect on this account for whatever reason will be the responsibility of the customer. By signing this proposal, the customer has completely reviewed and agreed with the prices, specifications and conditions as stated herein. Furthermore, customer is authorizing American Fence Company to complete the work. The customer is financially responsible for cancellation fees and costs of special-order materials in the event the customer elects to cancel the contract. TERMS: 60% Down. Balance due on substantial completion. Service and handling charges of 5% per month-60% per annum will apply to delinquent accounts past 10 days. The customer acknowledges that this is page two of two and has received page one.

By signing below, I acknowledge and agree with all stated herein inclusive of both pages one and two of this proposal.

Customer signature: _____ Date: _____

Customer printed name: _____ Date: _____

Customer invoicing email address: _____



Raven Elementary School

5' walk gate

5' walk gate

8' double drive gate

Measure distance
Click on the map to add to your path