

## **Board of Education Regular Meeting**

Tuesday, July 12, 2016 6:00 PM

Conference Room  
520 East 9th Street  
Imperial, NE 69033

I. Call to Order

II. Pledge of Allegiance

III. Approval of Agenda

IV. Approval of Minutes

V. Approval of Financial Report

VI. Public Comment

### **VII. Reports**

1. Activity Director

2. Principals

3. Student Board Member

4. Superintendent

### **VIII. Action Items**

1. Take all necessary action to approve Coke/Pepsi contract

2. Take all necessary action to approve 2016-17 substitute rate.

3. Open Public Hearing on Policy JM - Student Fees - to discuss, consider, and receive input

4. Close Hearing

5. Discuss, consider and take any action on Policy JM - Student Fees

6. Take all necessary action to appoint Joseph Lefdal as District Representative for local, state and federal programs for the 2016-17 school year

7. Take all necessary action to appoint Joey Lefdal as the district non-compliance officer, non-discrimination officer and Title IX coordinator for 2016-17 school year.

8. Take all necessary action to approve first reading of new and reaffirmed policies for the 2016-17 school year.

9. Take all necessary action to approve membership in NRCSA for the 2016-17 school year.

10. Take all necessary action to approve summer transportation

11. Take all necessary action to approve the purchase of the Jackson Crew 44CE dishwasher

12. Take all necessary action to approve the purchase of new swing sets and spinner

**IX. Discussion Items**

1. New addition and building maintenance

X. Adjourn

---

Board President

---

Board Secretary

**Board of Education Regular Meeting** June 14, 2016 6:00 PM Conference Room

**I. Call to Order** Discussion: President Olsen called the meeting to order at 6:02 pm and directed attention to the open meetings act.

**II. Pledge of Allegiance** Discussion: President Olsen led the assembly in the pledge of allegiance.

**III. Approval of Agenda Motion Passed:** Motion to approve the agenda as presented passed with a motion by Sheila Stromberger and a second by Karl Meeske. Thomas Gaschler-Yes, Karl Meeske-Yes, Willy O'Neil-Yes, Jeff Olsen-Yes, Dan Reeves-Yes, Gregg Smith-Yes, Penny Strand-Yes, Sheila Stromberger-Yes, Steve Wallin-Yes

**IV. Approval of Minutes Motion Passed:** Motion to approve the minutes as presented, and amended since published incorrectly noting changes to the voting record for Member Stromberger passed with a motion by Karl Meeske and a second by Willy O'Neil. Thomas Gaschler-Yes, Karl Meeske-Yes, Willy O'Neil-Yes, Jeff Olsen-Yes, Dan Reeves-Yes, Gregg Smith-Yes, Penny Strand-Yes, Sheila Stromberger-Yes, Steve Wallin-Yes

**Discussion:**

Please note the following corrections. The voting record from the May 10, 2016 meeting was incorrectly published as Shelia Stromberger-No on the following actions: VIII.C. Take all necessary action to approve all appointments and resignations Motion Passed: Motion to approve all appointments and resignations as presented passed with a motion by Karl Meeske and a second by Willy O'Neil. Thomas Gaschler-Yes, Karl Meeske-Yes, Willy O'Neil-Yes, Jeff Olsen-Yes, Dan Reeves-Yes, Gregg Smith-Yes, Penny Strand-Yes, Sheila Stromberger-Yes, Steve Wallin-Yes VIII.D. Take all necessary action to approve the 2016-17 breakfast and lunch prices Motion Passed: Motion to approve the 16-17 as is passed with a motion by Thomas Gaschler and a second by Willy O'Neil. Thomas Gaschler-Yes, Karl Meeske-Yes, Willy O'Neil-Yes, Jeff Olsen-Yes, Dan Reeves-Yes, Gregg Smith-Yes, Penny Strand-Yes, Sheila Stromberger-Yes, Steve Wallin-Yes VIII.F. Take all necessary action to approve the bid from Specialty Installation Motion Passed: Motion to approve the bid from Specialty Installation for \$24,850 passed with a motion by Karl Meeske and a second by Sheila Stromberger. Thomas Gaschler-Yes, Karl Meeske-Yes, Willy O'Neil-Yes, Jeff Olsen-Yes, Dan Reeves-Yes, Gregg Smith-Yes, Penny Strand-Yes, Sheila Stromberger-Yes, Steve Wallin-Yes VIII.G. Take all necessary action to approve the AIA contract with Studio 120 Motion Passed: Motion to approve the AIA contract with Studio 120 passed with a motion by Steve Wallin and a second by Willy O'Neil. Thomas Gaschler-Yes, Karl Meeske-Yes, Willy O'Neil-Yes, Jeff Olsen-Yes, Dan Reeves-Yes, Gregg Smith-Yes, Penny Strand-Yes, Sheila Stromberger-Yes, Steve Wallin-Yes VIII.I. Take all necessary action to approve the 2016 Category 2 erate bid in the amount of \$15,219 with 20/20 Technologies Motion Passed: Motion to approve the 2016 Category 2 erate bid in the amount of \$15,219 with 20/20 Technologies passed with a motion by Karl Meeske and a second by Thomas Gaschler. Thomas Gaschler-Yes, Karl Meeske-Yes, Willy O'Neil-Yes, Jeff Olsen-Yes, Dan Reeves-Yes, Gregg Smith-Yes, Penny Strand-Yes, Sheila Stromberger-Yes, Steve Wallin-Yes VIII.J. Take all necessary action to approve the proposed list of 2016 graduates Motion Passed: Motion to approve the proposed list of 2016 graduates passed with a motion by Willy O'Neil and a second by Thomas Gaschler. Thomas Gaschler-Yes, Karl Meeske-Yes, Willy O'Neil-Yes, Jeff Olsen-Yes, Dan Reeves-Yes, Gregg Smith-Yes, Penny Strand-Yes, Sheila Stromberger-Yes, Steve Wallin-Yes VIII.K. Take all necessary action to approve Studio 120 to release bids for construction of the northeast addition Motion Passed: Motion to approve Studio 120 to release bids for construction of the northeast addition passed with a motion by Sheila Stromberger and a second by Steve Wallin. Thomas Gaschler-Yes, Karl Meeske- Yes, Willy O'Neil-Yes, Jeff Olsen-Yes, Dan Reeves-Yes, Gregg Smith-Yes, Penny Strand-Yes, Sheila

Stromberger-Yes, Steve Wallin-Yes

**V. Approval of Financial Report Motion Passed:** Motion to approve the financial report in the amount of \$579,955.24 General payments and \$15,857.50 QCPUF Bond Interest payment as presented passed with a motion by Karl Meeske and a second by Willy O'Neil. Thomas Gaschler-Yes, Karl Meeske-Yes, Willy O'Neil-Yes, Jeff Olsen-Yes, Dan Reeves-Yes, Gregg Smith-Yes, Penny Strand-Yes, Sheila Stromberger-Yes, Steve Wallin-Yes

**VI. Public Comment** None noted.

### **VII. Reports**

**VII.A. Activity Director** Discussion: Mr. Hauxwell discussed the Marine Camp that was held last week. Over 40 students participated. Mr. Hauxwell felt the experience was a positive one, with the focus on teamwork & leadership skills. Weight lifting started June 6th-attendance is good, he noted more girls and junior high students attending this summer. Volleyball, wrestling, and basketball camps are going on this month. Hauxwell noted the transportation schedule is very busy right now. Hauxwell discussed the Pepsi and Coke contract, neither company will donate for score boards anymore, but will donate money towards the school to use for necessary items. Pepsi seems to provide a lot more so Hauxwell is anticipating continuing with them. Board member Sheila Stromberger inquired whether the students could find their own transportation to camps. Hauxwell noted that a transportation handbook would be drafted & possibly reviewed by next board meeting.

**VII.B. Principals** Discussion: Principal Scheel highlighted NESAs testing & some of the changes that will be taking place going forward with those tests. Two teachers for middle school will be attending training sessions and Scheel and Oden will be accompanying. Staff meeting for 9-12th unveiled rebranding of advisory time. Time was added of 30-40 minutes & it will be called MIC-Time (Mentorship & Intervention Classes-Think, Improvement, Maximize, Excellence) Students will complete 9 week courses that either help them relearn basic skills in Math, Science, or Reading (Those will be called "Focus" classes)...the mentorship side, students will complete 9-week leadership and service experience. Mr. Scheel & Mrs. Oden have met with Kelly Erickson from ESU a couple times to help with staff development & instructional development to help grow teachers in education in which they can enhance their skill set in teaching our students. Mr. Scheel plans on continuing walking through classes to monitor and advise on what teachers can do to help improve their practices & teachers will turn in a reflection that entails how they will improve their lessons and goals for their classes. Teachers will also accompany him in some of the walk through session so they can advise and help other teachers. Mrs. Oden was absent. Mr. Lefdal gave summary of what is happening in elementary. Painting and new carpet in some of the elementary classrooms. Migrant summer classes started June 8th and will go until June 17th.

**VII.C. Student Board Member** Discussion: No student Board Member present.

**VII.D. Superintendent** Rationale: Congrats to the Chase County Girl's Track Team for their state championship. Spoke with Nick Schultz to discuss footings for track shed. Spoke with Tom Luhrs regarding appraisal for Wellington-3 months. Starting budget forms-handbooks, HAL and after school programming, Re-key locks on exterior doors, CDC Reports and NSSRS, Increase in PT/OT, Law and Handbook wkshps, Meet with Seniors Thursday, Transfer to Activity next month, HAL discussion/Middle School update, 2017-18 Calendar, Graduation Requirements, End of the year-Reflect on year, curr. review, district goals, Superintendent evaluation, Playground Discussion: Supt. Lefdal congratulated Mr. Hauxwell & the girls track team for bringing home the Class C Championship trophy. Lefdal noted that he spoke with Nick Schultz regarding the implementation of track shed. Lefdal & Board discussed scheduling an appraisal for the Wellington School Building. Board would like an estimate of what an appraisal will cost and whether it was premature to have an appraisal done right now if the

building isn't being sold right away. Supt Lefdal will be following up on appraisal questions. High ability learning program-(HAL) will be re-hauled for next school year, Greg Meyer will be overseeing the program/instruction for all kids in each classroom, starting in elementary up to high school on a rotating basis. Engaging in more hands on programs. Supt Lefdal also discussed adding an after school program which will add mentors from high school & address concerns with at risk students. Discussion to re-key locks on exterior doors to building. CDC, NSSRS reports are due June 15th, PT/OT services are seeing a large increase in number of students, discussion by Lefdal about hiring more paras to meet rising needs. Mr. Scheel and Lefdal attended a workshop addressing the laws in handbooks & expressed that the school handbooks will need rewritten accordingly. Handful of outgoing seniors will be going to lunch with Scheel and Lefdal to voice feedback on how we can improve the school and programs. Conversation about graduation requirements will be held next month meeting. District goals: Board Retreat, focusing on our goals, or go off NSAB or suggestions. Supt Lefdal inquired about doing the retreat an hour before board meeting. Supt. evaluation will be handed out & and the board committee for the evaluation will meet. Other board members can talk to someone on the committee if they have opinions that they want to share. Met with Crouch Recreation on playground equipment, have lots of playground equipment that needs fixed and repaired. Need to look at new swing sets, Board Member Sheila Stromberger suggested researching to see if there is a grant available for playground equipment. PTO will also be contacted to see if they would like to fund raise for the equipment.

#### **VIII. Action Items**

##### **VIII.A. Take all necessary action to approve CDI computer and licensing purchase of \$57,000**

**Motion Passed:** Motion to approve CDI computer and licensing purchase of \$57,000 passed with a motion by Willy O'Neil and a second by Thomas Gaschler. Thomas Gaschler-Yes, Karl Meeske-Yes, Willy O'Neil-Yes, Jeff Olsen-Yes, Dan Reeves-Yes, Gregg Smith-Yes, Penny Strand-Yes, Sheila Stromberger -Yes, Steve Wallin-Yes  
Discussion: Principal Scheel discussed the new computer policy regarding the use of the new Chromebooks. Board Member Stromberger inquired if all students have to sign a computer usage contract, Supt Lefdal stated that they do now & that will continue. Discussion led to pros of using Chromebooks in lieu of Mac computers & educating students on proper usage of computer and apps & the 4th-8th grade students will not have a computer assigned to them personally, the computers will be staying at the school. Principal Scheel stated that 7th-8th grade will be allowed to check out the computers if there is a school project etc. Inquiries about inventory of computers which Supt Lefdal stated is being done this summer along with other inventory in the school & all will be tracked through the accounting software.

##### **VIII.B. Take all necessary action to approve the purchase of Odysseyware programming**

Discussion: Supt Lefdal discussed the purchase of Odyssey software which is a software program that provides an interactive environment for learning and exploration online. The program is mainly for students who would like independent work instead of being in a classroom. Students will get full credit for these courses. Supt. Lefdal stated he had 5 students interested in utilizing the program already. Lefdal also stated the ability to tie our course work to our standards and math assessments is great with this program. Principal Scheel pointed out that a teacher needs to be tied & certified in the course. Board Member Greg Smith asked if science classes would meet our standards for course work. Lefdal stated it would.

##### **VIII.C. Take all necessary action to approve all appointments and resignations**

Rationale: Darcia Boman-Jr. class sponsor, Chelsea Zuege-Class of 2018 sponsor, Jill Bauerle-Class Of 2020 sponsor, Shane Gerhartz-Technology Integration Specialist  
**Motion Passed:** Motion to approve all appointments and resignations as presented passed with a motion by Gregg Smith and a second by Sheila Stromberger. Thomas Gaschler-Yes, Karl Meeske-Yes, Willy O'Neil-Yes, Jeff Olsen-Yes, Dan Reeves-Yes, Gregg Smith-Yes, Penny Strand-Yes, Sheila Stromberger-Yes, Steve Wallin-Yes

**VIII.D. Take all necessary action to approve Heartland roofing contract Motion**

**Passed:** Motion to approve Heartland roofing contract passed by Gregg Smith and seconded by Karl Meeske. Prior to vote, noted incorrect superintendent name and dates of agreement were questioned, therefore, Board moved to withdraw original motion. Motion to approve Heartland roofing contract corrected as noted passed with a motion by Gregg Smith and a second by Dan Reeves. Thomas Gaschler-Yes, Karl Meeske-Yes, Willy O'Neil-Yes, Jeff Olsen-Yes, Dan Reeves-Yes, Gregg Smith-Yes, Penny Strand-Yes, Sheila Stromberger-Yes, Steve Wallin-Yes Discussion: Board Member Penny Strand inquired if the price in the contract included service calls or repair work. Supt, Lefdal stated it included preventative maintenance only.

**IX. Discussion Items**

**IX.A. Student Fees** Discussion: Supt Lefdal discussed removing P.E uniform & computer fees. Board Member Penny Strand inquired about what the students would be required to wear if there was no uniforms & shared concern with clothes meeting school clothing requirements & how those rules would be enforced. Discussion led into computer fees & whether or not those fees still needed to be passed on with new Chromebooks replacing the current Macs. Question was asked by Lefdal about keeping student fees or where we could evaluate removing. Board Member Willy O'Neil inquired about total cost of fees school passes onto students. Supt Lefdal stated he would gather report of total fees & email out to the board members to look over & discuss next board meeting.

**IX.B. Student/Parent Handbooks, Transportation Handbook, Classified Handbook**

**Teacher/Mentor Handbook** Discussion: Supt. Lefdal would like to get the new transportation handbook done prior to July board meeting. Lefdal stated he is working on the handbooks for improvements and additional changes & revising legally.

**IX.C. NeSA and NWEA assessments** Discussion: Touch on NWEA assessment. Supt Lefdal stated scores have improved. Lefdal noted that there hasn't been consistent testing over the years, difficult to map growth consistently. Supt Lefdal stated that more research is needed because we are lacking in college and career readiness. Discussion concerning mapping High Ability learners, how do we help kids in each core area? Supt Lefdal stated MAPS will help with those gaps. Lefdal showed graphing examples and discussed data & how that data helps set programs for students that will help develop positive growth & bridge those gaps in student learning.

**IX.D. Bright Bytes survey results** Discussion: None at this time.

**IX.E. School Improvement Rationale:** <https://www.advanc-ed.org/about-us> Discussion: Set for next year. Supt Lefdal inquired about volunteers from board to be on committee to come up with ideas on school improvement plans & developing a mission statement & setting new goals for students. Review will be next spring. Mr. Scheel and Mrs. Odens will be attending programs.

**IX.F. Trane update** Discussion: Supt Lefdal stated a compressor went out and needed replaced. Humidity is an issue.

**IX.G. First Book Marketplace** Discussion: Supt Lefdal discussed The First Book Marketplace which is an online bookstore offering eligible community programs and schools Newbery and Caldecott award winners and other high-quality children's books at prices 50 to 90 percent below retail. This program serves low-income, Title 1 eligible schools. Students will have own log in and have access to books. This is available online for each students. 3rd-8th grade will have the ability to access. Supt Lefdal downloaded 400 licenses. There is an app that will be available on chromebooks as well.

**IX.H. Board policy update** Discussion: Supt Lefdal stated the board policies needed to be rewritten & reviewed by attorney so they meet all legal standards.

**IX.I. Building update** Rationale: Bus barn, June 16th 1:30 bid opening, and summer work Discussion: Supt Lefdal stated construction bids are opening on June 16th. General upkeep of building is being done this summer. Restroom by elementary office will be remodeled into a handicapped bathroom.

**IX.J. Annual Review of Policy JIA - Violence Free/Anti-Bullying Policy**

Discussion: Supt Lefdal stated the Violence Free/Anti-Bullying Policy needs redone every year.

**X. Adjourn** Discussion: Meeting adjourned at 8:40 P.M.

---

Board President

---

Board Secretary

Cycle: FY15-16; Begin Date: 9/1/2015; End Date: 7/12/2016; Primary Sort Element: Fund; Secondary Sort Element: Function; Account List: ((Function] Between '1000' AND '9000') AND ([Fund] = '01') AND ([Object] Between '000' AND '755')

Primary Sort Element	Secondary Sort Element
01	Function:1100 - REGULAR INSTRUCTIONAL PROGRAMS

Account Code	Description	Adopted Budget	Current Budget	Budget Actuals	YTD Actuals	Encumbrance	Projected	YTD Available
01-1100-110-00	Salaries-teacher	\$ 2,123,417.00	\$ 2,123,417.00	\$ 1,902,588.36	\$ 1,902,588.36	\$ -	\$ 1,902,588.36	\$ 220,828.64
01-1100-111-00	Salaries-ESU Sti	\$ 750.00	\$ 750.00	\$ 4,543.50	\$ 4,543.50	\$ -	\$ 4,543.50	\$ (3,793.50)
01-1100-112-00	Schedule B	\$ 148,439.00	\$ 148,439.00	\$ 127,528.04	\$ 127,528.04	\$ -	\$ 127,528.04	\$ 20,910.96
01-1100-115-00	Schedule B	\$ -	\$ -	\$ 11,819.99	\$ 11,819.99	\$ -	\$ 11,819.99	\$ (11,819.99)
01-1100-120-00	Sal-sub	\$ 68,000.00	\$ 68,000.00	\$ 102,694.58	\$ 102,694.58	\$ -	\$ 102,694.58	\$ (34,694.58)
01-1100-130-00	Sal - Staff Develp	\$ 5,000.00	\$ 5,000.00	\$ 561.16	\$ 561.16	\$ -	\$ 561.16	\$ 4,438.84
01-1100-140-00	Sal-clerks-aides	\$ -	\$ -	\$ 20.00	\$ 20.00	\$ -	\$ 20.00	\$ (20.00)
01-1100-150-00	Benefit payout U	\$ 15,000.00	\$ 15,000.00	\$ 2,561.00	\$ 2,561.00	\$ -	\$ 2,561.00	\$ 12,439.00
01-1100-210-00	Social Security	\$ 175,709.00	\$ 175,709.00	\$ 158,366.12	\$ 158,366.12	\$ -	\$ 158,366.12	\$ 17,342.88
01-1100-220-00	Retirement	\$ 221,307.00	\$ 221,307.00	\$ 200,263.08	\$ 200,263.08	\$ -	\$ 200,263.08	\$ 21,043.92
01-1100-230-00	Health Ins	\$ 443,275.00	\$ 443,275.00	\$ 416,684.57	\$ 416,684.57	\$ -	\$ 416,684.57	\$ 26,590.43
01-1100-231-00	Health Ins. - Ded	\$ 28,350.00	\$ 28,350.00	\$ -	\$ -	\$ -	\$ -	\$ 28,350.00
01-1100-290-00	Other Emp Bene	\$ 5,222.00	\$ 5,222.00	\$ 5,025.71	\$ 5,025.71	\$ -	\$ 5,025.71	\$ 196.29
01-1100-319-00	Repair	\$ 10,400.00	\$ 10,400.00	\$ 2,123.72	\$ 2,123.72	\$ 1,243.10	\$ 3,366.82	\$ 7,033.18
01-1100-319-20	Repair	\$ -	\$ -	\$ 1,848.10	\$ 1,848.10	\$ -	\$ 1,848.10	\$ (1,848.10)
01-1100-410-00	Supplies	\$ 100,000.00	\$ 100,000.00	\$ 39,689.60	\$ 39,689.60	\$ 21,899.01	\$ 61,588.61	\$ 38,411.39
01-1100-410-10	Supplies	\$ -	\$ -	\$ 5,346.13	\$ 5,346.13	\$ 1,097.25	\$ 6,443.38	\$ (6,443.38)
01-1100-410-20	Supplies	\$ -	\$ -	\$ 3,350.76	\$ 3,350.76	\$ 329.55	\$ 3,680.31	\$ (3,680.31)
01-1100-410-20	REGULAR INST	\$ -	\$ -	\$ -	\$ -	\$ -	\$ -	\$ -
01-1100-411-00	Field Trips	\$ -	\$ -	\$ 1,113.52	\$ 1,113.52	\$ -	\$ 1,113.52	\$ (1,113.52)
01-1100-420-00	Textbooks	\$ 70,000.00	\$ 70,000.00	\$ 3,046.72	\$ 3,046.72	\$ 1,690.67	\$ 4,737.39	\$ 65,262.61
01-1100-420-10	Textbooks	\$ -	\$ -	\$ 1,596.67	\$ 1,596.67	\$ -	\$ 1,596.67	\$ (1,596.67)
01-1100-420-20	Textbooks	\$ -	\$ -	\$ 662.00	\$ 662.00	\$ -	\$ 662.00	\$ (662.00)
01-1100-425-00	E-BOOKS	\$ -	\$ -	\$ -	\$ -	\$ 6,010.44	\$ 6,010.44	\$ (6,010.44)
01-1100-440-00	Periodicals	\$ 4,375.00	\$ 4,375.00	\$ 125.25	\$ 125.25	\$ 1,127.25	\$ 1,252.50	\$ 3,122.50
01-1100-440-10	Periodicals	\$ -	\$ -	\$ -	\$ -	\$ -	\$ -	\$ -
01-1100-440-20	Periodicals	\$ -	\$ -	\$ 139.00	\$ 139.00	\$ -	\$ 139.00	\$ (139.00)
01-1100-450-00	Audio-visual	\$ 5,000.00	\$ 5,000.00	\$ 388.90	\$ 388.90	\$ -	\$ 388.90	\$ 4,611.10
01-1100-450-20	Audio Visual	\$ -	\$ -	\$ -	\$ -	\$ -	\$ -	\$ -
01-1100-460-00	Software	\$ 90,750.00	\$ 90,750.00	\$ 65,675.10	\$ 65,675.10	\$ 378.00	\$ 66,053.10	\$ 24,696.90
01-1100-460-20	Software	\$ -	\$ -	\$ 558.00	\$ 558.00	\$ -	\$ 558.00	\$ (558.00)
01-1100-465-00	REGULAR INST	\$ 1,500.00	\$ 1,500.00	\$ 7,500.00	\$ 7,500.00	\$ 132.19	\$ 7,632.19	\$ (6,132.19)
01-1100-467-00	Web/Cloud Base	\$ 2,800.00	\$ 2,800.00	\$ 2,350.00	\$ 2,350.00	\$ -	\$ 2,350.00	\$ 450.00
01-1100-490-00	Other Supplies &	\$ 6,500.00	\$ 6,500.00	\$ 13,951.49	\$ 13,951.49	\$ 150.00	\$ 14,101.49	\$ (7,601.49)
01-1100-530-00	Furn And Equip	\$ 24,300.00	\$ 24,300.00	\$ 9,542.98	\$ 9,542.98	\$ 5,758.04	\$ 15,301.02	\$ 8,998.98
01-1100-530-10	Furniture & Equip	\$ -	\$ -	\$ 1,728.39	\$ 1,728.39	\$ -	\$ 1,728.39	\$ (1,728.39)
01-1100-530-20	Furniture & Equip	\$ -	\$ -	\$ 2,164.00	\$ 2,164.00	\$ -	\$ 2,164.00	\$ (2,164.00)
01-1100-531-00	Lease-purchase	\$ 13,500.00	\$ 13,500.00	\$ -	\$ -	\$ -	\$ -	\$ 13,500.00
01-1100-560-00	Computer Equip	\$ 1,000.00	\$ 1,000.00	\$ 2,071.67	\$ 2,071.67	\$ 689.00	\$ 2,760.67	\$ (1,760.67)
01-1100-630-00	Dues & Fees	\$ 10,950.00	\$ 10,950.00	\$ 3,863.00	\$ 3,863.00	\$ 110.00	\$ 3,973.00	\$ 6,977.00
01-1100-630-10	Dues & Fees	\$ -	\$ -	\$ 216.00	\$ 216.00	\$ -	\$ 216.00	\$ (216.00)
01-1100-630-20	Dues & Fees	\$ -	\$ -	\$ 600.00	\$ 600.00	\$ -	\$ 600.00	\$ (600.00)
01-1100-630-21	REGULAR INST	\$ -	\$ -	\$ 1,123.75	\$ 1,123.75	\$ -	\$ 1,123.75	\$ (1,123.75)
01-1100-670-00	Travel &Lodge	\$ 20,650.00	\$ 20,650.00	\$ 5,186.92	\$ 5,186.92	\$ -	\$ 5,186.92	\$ 15,463.08
01-1100-670-10	TravLodgMilMea	\$ -	\$ -	\$ 110.00	\$ 110.00	\$ -	\$ 110.00	\$ (110.00)
01-1100-670-20	TravLodgMilMea	\$ -	\$ -	\$ 597.27	\$ 597.27	\$ -	\$ 597.27	\$ (597.27)
01-1100-690-00	All Other	\$ 10,000.00	\$ 10,000.00	\$ 2,599.79	\$ 2,599.79	\$ -	\$ 2,599.79	\$ 7,400.21
01-1100-690-10	All Other	\$ -	\$ -	\$ 799.96	\$ 799.96	\$ -	\$ 799.96	\$ (799.96)
01-1100-690-20	All Other	\$ -	\$ -	\$ 327.54	\$ 327.54	\$ -	\$ 327.54	\$ (327.54)
<b>Subtotal</b>		<b>\$ 3,606,194.00</b>	<b>\$ 3,606,194.00</b>	<b>\$ 3,113,052.34</b>	<b>\$ 3,113,052.34</b>	<b>\$ 40,614.50</b>	<b>\$ 3,153,666.84</b>	<b>\$ 452,527.16</b>

Primary Sort Element	Secondary Sort Element
01	Function:1150 - LIMITED ENGLISH PROFICIENCY PROGRAMS

Account Code	Description	Adopted Budget	Current Budget	Budget Actuals	YTD Actuals	Encumbrance	Projected	YTD Available
01-1150-110-00	E.L.L. Salaries-te	\$ 118,255.00	\$ 118,255.00	\$ 108,400.38	\$ 108,400.38	\$ -	\$ 108,400.38	\$ 9,854.62

Cycle: FY15-16; Begin Date: 9/1/2015; End Date: 7/12/2016; Primary Sort Element: Fund; Secondary Sort Element: Function; Account List: ((Function) Between '1000' AND '9000') AND ((Fund) = '01') AND ((Object) Between '000' AND '755')

01-1150-120-00(E.L.L. Salaries -	\$ 3,200.00	\$ 3,200.00	\$ 2,704.75	\$ 2,704.75	\$ -	\$ 2,704.75	\$ 495.25
01-1150-140-00(E.L.L. Salaries -	\$ 12,200.00	\$ 12,200.00	\$ 18,017.88	\$ 18,017.88	\$ -	\$ 18,017.88	\$ (5,817.88)
01-1150-145-00(Overtime	\$ 500.00	\$ 500.00	\$ 77.50	\$ 77.50	\$ -	\$ 77.50	\$ 422.50
01-1150-210-00(E.L.L. Social Sec	\$ 10,230.00	\$ 10,230.00	\$ 9,570.50	\$ 9,570.50	\$ -	\$ 9,570.50	\$ 659.50
01-1150-220-00(E.L.L. Retiremen	\$ 12,886.00	\$ 12,886.00	\$ 12,494.99	\$ 12,494.99	\$ -	\$ 12,494.99	\$ 391.01
01-1150-230-00(E.L.L. Health Ins	\$ 25,148.00	\$ 25,148.00	\$ 16,961.68	\$ 16,961.68	\$ -	\$ 16,961.68	\$ 8,186.32
01-1150-231-00(E.L.L. Health Ins	\$ 1,350.00	\$ 1,350.00	\$ -	\$ -	\$ -	\$ -	\$ 1,350.00
01-1150-290-00(E.L.L. Other Em	\$ 326.00	\$ 326.00	\$ 311.70	\$ 311.70	\$ -	\$ 311.70	\$ 14.30
01-1150-410-00(E.L.L. Supplies	\$ 750.00	\$ 750.00	\$ 605.19	\$ 605.19	\$ 189.17	\$ 794.36	\$ (44.36)
01-1150-420-00(ELL Textbooks	\$ 22,000.00	\$ 22,000.00	\$ 20,377.50	\$ 20,377.50	\$ -	\$ 20,377.50	\$ 1,622.50
01-1150-450-00(ELL Audio-visual	\$ 500.00	\$ 500.00	\$ 360.30	\$ 360.30	\$ 441.74	\$ 802.04	\$ (302.04)
01-1150-530-00(ELL Furn And Ec	\$ 500.00	\$ 500.00	\$ -	\$ -	\$ 322.96	\$ 322.96	\$ 177.04
01-1150-670-00(ELL Travel	\$ 1,000.00	\$ 1,000.00	\$ 617.24	\$ 617.24	\$ -	\$ 617.24	\$ 382.76
01-1150-690-00(E.L.L. All Others	\$ 1,000.00	\$ 1,000.00	\$ 373.00	\$ 373.00	\$ -	\$ 373.00	\$ 627.00

**Subtotal** \$ 209,845.00 \$ 209,845.00 \$ 190,872.61 \$ 190,872.61 \$ 953.87 \$ 191,826.48 \$ 18,018.52

**Primary Sort Element: 01 Secondary Sort Element: Function:1160 - POVERTY PROGRAMS**

Account Code	Description	Adopted Budge	Current Budget	Actuals	YTD Actuals	Encumbrance	Projected	YTD Available
01-1160-110-00(Poverty Program	\$ 51,590.00	\$ 51,590.00	\$ 48,156.46	\$ 48,156.46	\$ -	\$ 48,156.46	\$ 3,433.54	
01-1160-120-00(Poverty Program	\$ 5,800.00	\$ 5,800.00	\$ 14,740.53	\$ 14,740.53	\$ -	\$ 14,740.53	\$ (8,940.53)	
01-1160-140-00(Poverty Program	\$ 114,800.00	\$ 114,800.00	\$ 95,032.17	\$ 95,032.17	\$ -	\$ 95,032.17	\$ 19,767.83	
01-1160-145-00(Overtime	\$ 2,700.00	\$ 2,700.00	\$ 2,632.17	\$ 2,632.17	\$ -	\$ 2,632.17	\$ 67.83	
01-1160-210-00(Poverty Program	\$ 12,974.00	\$ 12,974.00	\$ 10,962.15	\$ 10,962.15	\$ -	\$ 10,962.15	\$ 2,011.85	
01-1160-220-00(Poverty Program	\$ 16,435.00	\$ 16,435.00	\$ 15,584.55	\$ 15,584.55	\$ -	\$ 15,584.55	\$ 850.45	
01-1160-230-00(Poverty Program	\$ 35,165.00	\$ 35,165.00	\$ 31,909.41	\$ 31,909.41	\$ -	\$ 31,909.41	\$ 3,255.59	
01-1160-231-00(Poverty Program	\$ 3,150.00	\$ 3,150.00	\$ -	\$ -	\$ -	\$ -	\$ 3,150.00	
01-1160-290-00(Poverty Program	\$ 420.00	\$ 420.00	\$ 355.07	\$ 355.07	\$ -	\$ 355.07	\$ 64.93	
01-1160-410-00(Poverty Program	\$ 1,000.00	\$ 1,000.00	\$ -	\$ -	\$ -	\$ -	\$ 1,000.00	
01-1160-420-00(Poverty Textboo	\$ 500.00	\$ 500.00	\$ -	\$ -	\$ -	\$ -	\$ 500.00	
01-1160-450-00(Poverty Audio-vi	\$ 500.00	\$ 500.00	\$ -	\$ -	\$ -	\$ -	\$ 500.00	
01-1160-690-00(Poverty Program	\$ 750.00	\$ 750.00	\$ -	\$ -	\$ -	\$ -	\$ 750.00	

**Subtotal** \$ 245,784.00 \$ 245,784.00 \$ 219,372.51 \$ 219,372.51 \$ - \$ 219,372.51 \$ 26,411.49

**Primary Sort Element: 01 Secondary Sort Element: Function:1200 - SPECIAL EDUCATION INSTRUCTIONAL PROGRAMS**

Account Code	Description	Adopted Budge	Current Budget	Actuals	YTD Actuals	Encumbrance	Projected	YTD Available
01-1200-110-00(Salary	\$ 110,720.00	\$ 110,720.00	\$ 103,140.40	\$ 103,140.40	\$ -	\$ 103,140.40	\$ 7,579.60	
01-1200-120-00(Sal-subs	\$ 7,000.00	\$ 7,000.00	\$ 12,309.29	\$ 12,309.29	\$ -	\$ 12,309.29	\$ (5,309.29)	
01-1200-140-00(Sal-aides	\$ 149,682.00	\$ 149,682.00	\$ 130,545.60	\$ 130,545.60	\$ -	\$ 130,545.60	\$ 19,136.40	
01-1200-145-00(Overtime	\$ 3,500.00	\$ 3,500.00	\$ 5,126.16	\$ 5,126.16	\$ -	\$ 5,126.16	\$ (1,626.16)	
01-1200-210-00(Social Security	\$ 20,721.00	\$ 20,721.00	\$ 16,518.41	\$ 16,518.41	\$ -	\$ 16,518.41	\$ 4,202.59	
01-1200-220-00(Retirement	\$ 25,722.00	\$ 25,722.00	\$ 23,384.72	\$ 23,384.72	\$ -	\$ 23,384.72	\$ 2,337.28	
01-1200-230-00(Health Ins	\$ 67,200.00	\$ 67,200.00	\$ 61,378.63	\$ 61,378.63	\$ -	\$ 61,378.63	\$ 5,821.37	
01-1200-231-00(Health Ins Deduc	\$ 4,950.00	\$ 4,950.00	\$ -	\$ -	\$ -	\$ -	\$ 4,950.00	
01-1200-290-00(Other Emp Bene	\$ 651.00	\$ 651.00	\$ 575.51	\$ 575.51	\$ -	\$ 575.51	\$ 75.49	
01-1200-350-00(Advertising & Pri	\$ 500.00	\$ 500.00	\$ 595.00	\$ 595.00	\$ -	\$ 595.00	\$ (95.00)	
01-1200-363-00(SA-Tuition Other	\$ 275,000.00	\$ 275,000.00	\$ 304,009.09	\$ 304,009.09	\$ -	\$ 304,009.09	\$ (29,009.09)	
01-1200-410-00(Supplies	\$ 3,000.00	\$ 3,000.00	\$ 3,158.53	\$ 3,158.53	\$ 2,030.00	\$ 5,188.53	\$ (2,188.53)	
01-1200-410-10(Supplies	\$ -	\$ -	\$ 593.63	\$ 593.63	\$ 170.91	\$ 764.54	\$ (764.54)	
01-1200-410-20(Supplies	\$ -	\$ -	\$ 411.21	\$ 411.21	\$ 1,048.74	\$ 1,459.95	\$ (1,459.95)	
01-1200-420-00(Textbooks	\$ 1,000.00	\$ 1,000.00	\$ -	\$ -	\$ -	\$ -	\$ 1,000.00	
01-1200-420-20(Textbooks	\$ -	\$ -	\$ -	\$ -	\$ 29.95	\$ 29.95	\$ (29.95)	
01-1200-450-20(Audio Visual	\$ -	\$ -	\$ -	\$ -	\$ 268.74	\$ 268.74	\$ (268.74)	
01-1200-530-00(Furn And Equip	\$ 1,500.00	\$ 1,500.00	\$ -	\$ -	\$ -	\$ -	\$ 1,500.00	
01-1200-530-10(Furniture & Equip	\$ -	\$ -	\$ 76.00	\$ 76.00	\$ -	\$ 76.00	\$ (76.00)	
01-1200-630-00(Dues & Fees	\$ 500.00	\$ 500.00	\$ -	\$ -	\$ -	\$ -	\$ 500.00	

Cycle: FY15-16; Begin Date: 9/1/2015; End Date: 7/12/2016; Primary Sort Element: Fund; Secondary Sort Element: Function; Account List: ((Function] Between '1000' AND '9000') AND ((Fund] = '01') AND ((Object] Between '000' AND '755')

01-1200-630-20( Dues & Fees	\$	-	\$	-	\$	420.00	\$	420.00	\$	110.00	\$	530.00	\$	(530.00)
01-1200-670-00( Travel	\$	1,000.00	\$	1,000.00	\$	-	\$	-	\$	-	\$	-	\$	1,000.00
01-1200-690-00( All Other	\$	1,000.00	\$	1,000.00	\$	470.05	\$	470.05	\$	-	\$	470.05	\$	529.95
<b>Subtotal</b>	<b>\$</b>	<b>673,646.00</b>	<b>\$</b>	<b>673,646.00</b>	<b>\$</b>	<b>662,712.23</b>	<b>\$</b>	<b>662,712.23</b>	<b>\$</b>	<b>3,658.34</b>	<b>\$</b>	<b>666,370.57</b>	<b>\$</b>	<b>7,275.43</b>

**Primary Sort El** Secondary Sort Element  
01 Function:1310 - GIFTED EDUCATION-H.A.L

Account Code	Description	Adopted Budge	Current Budget	Actuals	YTD Actuals	Encumbrance	Projected	YTD Available						
01-1310-110-00( H.A.L. Salary Te	\$	59,127.00	\$	59,127.00	\$	60,238.82	\$	60,238.82	\$	-	\$	60,238.82	\$	(1,111.82)
01-1310-120-00( HAL Subs	\$	700.00	\$	700.00	\$	769.00	\$	769.00	\$	-	\$	769.00	\$	(69.00)
01-1310-210-00( H.A.L. Social Sei	\$	4,523.00	\$	4,523.00	\$	4,460.13	\$	4,460.13	\$	-	\$	4,460.13	\$	62.87
01-1310-220-00( H.A.L. Retiremer	\$	5,841.00	\$	5,841.00	\$	5,905.81	\$	5,905.81	\$	-	\$	5,905.81	\$	(64.81)
01-1310-230-00( H.A.L. Health Ins	\$	6,215.00	\$	6,215.00	\$	6,409.37	\$	6,409.37	\$	-	\$	6,409.37	\$	(194.37)
01-1310-231-00( H.A.L. Health Ins	\$	450.00	\$	450.00	\$	-	\$	-	\$	-	\$	-	\$	450.00
01-1310-290-00( H.A.L. Other Em	\$	150.00	\$	150.00	\$	151.85	\$	151.85	\$	-	\$	151.85	\$	(1.85)
01-1310-410-00( H.A.L. Supplies	\$	700.00	\$	700.00	\$	107.00	\$	107.00	\$	48.94	\$	155.94	\$	544.06
01-1310-420-00( H.A.L. Textbooks:	\$	1,000.00	\$	1,000.00	\$	-	\$	-	\$	-	\$	-	\$	1,000.00
01-1310-630-00( HAL Dues and F	\$	400.00	\$	400.00	\$	-	\$	-	\$	-	\$	-	\$	400.00
01-1310-670-00( H.A.L. Travel	\$	1,000.00	\$	1,000.00	\$	-	\$	-	\$	-	\$	-	\$	1,000.00
01-1310-690-00( H.A.L. All Other	\$	200.00	\$	200.00	\$	-	\$	-	\$	-	\$	-	\$	200.00
<b>Subtotal</b>	<b>\$</b>	<b>80,306.00</b>	<b>\$</b>	<b>80,306.00</b>	<b>\$</b>	<b>78,041.98</b>	<b>\$</b>	<b>78,041.98</b>	<b>\$</b>	<b>48.94</b>	<b>\$</b>	<b>78,090.92</b>	<b>\$</b>	<b>2,215.08</b>

**Primary Sort El** Secondary Sort Element  
01 Function:1430 - TRADE INDUSTRIAL

Account Code	Description	Adopted Budge	Current Budget	Actuals	YTD Actuals	Encumbrance	Projected	YTD Available						
01-1430-440-00( Periodicals	\$	-	\$	-	\$	-	\$	-	\$	-	\$	-	\$	-
01-1430-530-00( Furn And Equip	\$	-	\$	-	\$	-	\$	-	\$	-	\$	-	\$	-
<b>Subtotal</b>	<b>\$</b>	<b>-</b>	<b>\$</b>	<b>-</b>	<b>\$</b>	<b>-</b>	<b>\$</b>	<b>-</b>	<b>\$</b>	<b>-</b>	<b>\$</b>	<b>-</b>	<b>\$</b>	<b>-</b>

**Primary Sort El** Secondary Sort Element  
01 Function:1450 - VO AG

Account Code	Description	Adopted Budge	Current Budget	Actuals	YTD Actuals	Encumbrance	Projected	YTD Available						
01-1450-336-00( Gas And Oil	\$	-	\$	-	\$	-	\$	-	\$	-	\$	-	\$	-
01-1450-410-00( Supplies	\$	-	\$	-	\$	1,039.97	\$	1,039.97	\$	-	\$	1,039.97	\$	(1,039.97)
01-1450-420-00( Textbooks	\$	-	\$	-	\$	-	\$	-	\$	-	\$	-	\$	-
01-1450-440-00( Periodicals	\$	-	\$	-	\$	-	\$	-	\$	-	\$	-	\$	-
<b>Subtotal</b>	<b>\$</b>	<b>-</b>	<b>\$</b>	<b>-</b>	<b>\$</b>	<b>1,039.97</b>	<b>\$</b>	<b>1,039.97</b>	<b>\$</b>	<b>-</b>	<b>\$</b>	<b>1,039.97</b>	<b>\$</b>	<b>(1,039.97)</b>

**Primary Sort El** Secondary Sort Element  
01 Function:1470 - DIVERSIFIED OC

Account Code	Description	Adopted Budge	Current Budget	Actuals	YTD Actuals	Encumbrance	Projected	YTD Available						
01-1470-110-00( Salary- DO	\$	-	\$	-	\$	6,361.96	\$	6,361.96	\$	-	\$	6,361.96	\$	(6,361.96)
01-1470-210-00( Social Security	\$	-	\$	-	\$	471.89	\$	471.89	\$	-	\$	471.89	\$	(471.89)
01-1470-220-00( Retirement	\$	-	\$	-	\$	628.40	\$	628.40	\$	-	\$	628.40	\$	(628.40)
01-1470-230-00( Health Ins	\$	-	\$	-	\$	2,222.99	\$	2,222.99	\$	-	\$	2,222.99	\$	(2,222.99)
01-1470-290-00( Other Emp Ben	\$	-	\$	-	\$	16.17	\$	16.17	\$	-	\$	16.17	\$	(16.17)
<b>Subtotal</b>	<b>\$</b>	<b>-</b>	<b>\$</b>	<b>-</b>	<b>\$</b>	<b>9,701.41</b>	<b>\$</b>	<b>9,701.41</b>	<b>\$</b>	<b>-</b>	<b>\$</b>	<b>9,701.41</b>	<b>\$</b>	<b>(9,701.41)</b>

**Primary Sort El** Secondary Sort Element  
01 Function:2120 - GUIDANCE SERVICES

Cycle: FY15-16; Begin Date: 9/1/2015; End Date: 7/12/2016; Primary Sort Element: Fund; Secondary Sort Element: Function; Account List: ((Function] Between '1000' AND '9000') AND ([Fund] = '01') AND ([Object] Between '000' AND '755')

Account Code	Description	Adopted Budget	Current Budget	Budget Actuals	YTD Actuals	Encumbrance	Projected	YTD Available
01-2120-110-00	Salary-guidance	\$ 53,833.00	\$ 53,833.00	\$ 48,156.56	\$ 48,156.56	\$ -	\$ 48,156.56	\$ 5,676.44
01-2120-210-00	Social Security	\$ 4,120.00	\$ 4,120.00	\$ 3,583.23	\$ 3,583.23	\$ -	\$ 3,583.23	\$ 536.77
01-2120-220-00	Retirement	\$ 5,320.00	\$ 5,320.00	\$ 4,756.66	\$ 4,756.66	\$ -	\$ 4,756.66	\$ 563.34
01-2120-230-00	Health Ins	\$ 14,845.00	\$ 14,845.00	\$ 13,608.43	\$ 13,608.43	\$ -	\$ 13,608.43	\$ 1,236.57
01-2120-231-00	Health Ins - Dedi	\$ 900.00	\$ 900.00	\$ -	\$ -	\$ -	\$ -	\$ 900.00
01-2120-290-00	Other Emp Bene	\$ 141.00	\$ 141.00	\$ 122.37	\$ 122.37	\$ -	\$ 122.37	\$ 18.63
01-2120-410-00	Supplies	\$ 3,500.00	\$ 3,500.00	\$ 967.39	\$ 967.39	\$ -	\$ 967.39	\$ 2,532.61
01-2120-410-10	Guidance Suppli	\$ -	\$ -	\$ 6.28	\$ 6.28	\$ 91.67	\$ 97.95	\$ (97.95)
01-2120-460-00	Guidance Softwa	\$ 400.00	\$ 400.00	\$ 395.00	\$ 395.00	\$ -	\$ 395.00	\$ 5.00
01-2120-530-00	Guidance Furnit	\$ 150.00	\$ 150.00	\$ -	\$ -	\$ -	\$ -	\$ 150.00
01-2120-530-10	Guidance Furnit	\$ -	\$ -	\$ 66.00	\$ 66.00	\$ -	\$ 66.00	\$ (66.00)
01-2120-630-00	Dues & Fees	\$ 1,000.00	\$ 1,000.00	\$ -	\$ -	\$ -	\$ -	\$ 1,000.00
01-2120-670-00	Guidance Travel	\$ 350.00	\$ 350.00	\$ 704.24	\$ 704.24	\$ -	\$ 704.24	\$ (354.24)
01-2120-670-10	Guidance Travel	\$ -	\$ -	\$ 75.00	\$ 75.00	\$ -	\$ 75.00	\$ (75.00)
01-2120-670-20	Guidance Travel	\$ -	\$ -	\$ 75.00	\$ 75.00	\$ -	\$ 75.00	\$ (75.00)
01-2120-690-00	All Other	\$ 750.00	\$ 750.00	\$ 1,098.72	\$ 1,098.72	\$ -	\$ 1,098.72	\$ (348.72)
01-2120-690-10	All Other	\$ -	\$ -	\$ 150.00	\$ 150.00	\$ -	\$ 150.00	\$ (150.00)
<b>Subtotal</b>		<b>\$ 85,309.00</b>	<b>\$ 85,309.00</b>	<b>\$ 73,764.88</b>	<b>\$ 73,764.88</b>	<b>\$ 91.67</b>	<b>\$ 73,856.55</b>	<b>\$ 11,452.45</b>

<b>Primary Sort El</b>	<b>Secondary Sort Element</b>
01	Function:2130 - HEALTH SERVICES

Account Code	Description	Adopted Budget	Current Budget	Budget Actuals	YTD Actuals	Encumbrance	Projected	YTD Available
01-2130-110-00	Sal-nurse	\$ 42,500.00	\$ 42,500.00	\$ 38,896.77	\$ 38,896.77	\$ -	\$ 38,896.77	\$ 3,603.23
01-2130-120-00	Salaries of Subs	\$ 1,000.00	\$ 1,000.00	\$ 888.97	\$ 888.97	\$ -	\$ 888.97	\$ 111.03
01-2130-210-00	Social Security	\$ 3,327.00	\$ 3,327.00	\$ 2,877.67	\$ 2,877.67	\$ -	\$ 2,877.67	\$ 449.33
01-2130-220-00	Retirement	\$ 4,198.00	\$ 4,198.00	\$ 3,842.15	\$ 3,842.15	\$ -	\$ 3,842.15	\$ 355.85
01-2130-230-00	Health	\$ 12,718.00	\$ 12,718.00	\$ 11,658.13	\$ 11,658.13	\$ -	\$ 11,658.13	\$ 1,059.87
01-2130-231-00	Health Ins - Dedi	\$ 900.00	\$ 900.00	\$ -	\$ -	\$ -	\$ -	\$ 900.00
01-2130-290-00	Other Benefits	\$ 106.00	\$ 106.00	\$ 98.84	\$ 98.84	\$ -	\$ 98.84	\$ 7.16
01-2130-410-00	Supplies	\$ 3,000.00	\$ 3,000.00	\$ 797.43	\$ 797.43	\$ 115.95	\$ 913.38	\$ 2,086.62
01-2130-450-00	Audio Visual	\$ -	\$ -	\$ 84.95	\$ 84.95	\$ -	\$ 84.95	\$ (84.95)
01-2130-530-00	Furn And Equip	\$ -	\$ -	\$ 10.50	\$ 10.50	\$ -	\$ 10.50	\$ (10.50)
01-2130-630-00	HEALTH SERVI	\$ -	\$ -	\$ 24.30	\$ 24.30	\$ 34.06	\$ 58.36	\$ (58.36)
01-2130-670-00	Travel	\$ 250.00	\$ 250.00	\$ 362.90	\$ 362.90	\$ 362.90	\$ 725.80	\$ (475.80)
01-2130-690-00	HEALTH SERVI	\$ 250.00	\$ 250.00	\$ -	\$ -	\$ -	\$ -	\$ 250.00
<b>Subtotal</b>		<b>\$ 68,249.00</b>	<b>\$ 68,249.00</b>	<b>\$ 59,542.61</b>	<b>\$ 59,542.61</b>	<b>\$ 512.91</b>	<b>\$ 60,055.52</b>	<b>\$ 8,193.48</b>

<b>Primary Sort El</b>	<b>Secondary Sort Element</b>
01	Function:2140 - PSYCHOLOGICAL SERVICES

Account Code	Description	Adopted Budget	Current Budget	Budget Actuals	YTD Actuals	Encumbrance	Projected	YTD Available
01-2140-313-00	Purchased Servi	\$ 15,000.00	\$ 15,000.00	\$ -	\$ -	\$ -	\$ -	\$ 15,000.00
<b>Subtotal</b>		<b>\$ 15,000.00</b>	<b>\$ 15,000.00</b>	<b>\$ -</b>	<b>\$ -</b>	<b>\$ -</b>	<b>\$ -</b>	<b>\$ 15,000.00</b>

<b>Primary Sort El</b>	<b>Secondary Sort Element</b>
01	Function:2150 - SAFETY & SECURITY

Account Code	Description	Adopted Budget	Current Budget	Budget Actuals	YTD Actuals	Encumbrance	Projected	YTD Available
01-2150-410-00	Supplies-safety	\$ 2,500.00	\$ 2,500.00	\$ -	\$ -	\$ -	\$ -	\$ 2,500.00
01-2150-530-00	Capital Outlay-sz	\$ 75,000.00	\$ 75,000.00	\$ -	\$ -	\$ -	\$ -	\$ 75,000.00
<b>Subtotal</b>		<b>\$ 77,500.00</b>	<b>\$ 77,500.00</b>	<b>\$ -</b>	<b>\$ -</b>	<b>\$ -</b>	<b>\$ -</b>	<b>\$ 77,500.00</b>

Cycle: FY15-16; Begin Date: 9/1/2015; End Date: 7/12/2016; Primary Sort Element: Fund; Secondary Sort Element: Function; Account List: ((Function] Between '1000' AND '9000') AND ((Fund] = '01') AND ((Object] Between '000' AND '755')

Primary Sort Element	Secondary Sort Element
01	Function:2222 - SCHOOL LIBRARY SERVICES

Account Code	Description	Adopted Budget	Current Budget	Budget Actuals	YTD Actuals	Encumbrance	Projected	YTD Available
01-2222-110-00	Salary-library	\$ 50,720.00	\$ 50,720.00	\$ -	\$ -	\$ -	\$ -	\$ 50,720.00
01-2222-120-00	Sal Of Sub	\$ 1,000.00	\$ 1,000.00	\$ 46,321.19	\$ 46,321.19	\$ -	\$ 46,321.19	\$ (45,321.19)
01-2222-140-00	Sal Of Aide	\$ 12,020.00	\$ 12,020.00	\$ 11,486.31	\$ 11,486.31	\$ -	\$ 11,486.31	\$ 533.69
01-2222-145-00	SCHOOL LIBRA	\$ 1,000.00	\$ 1,000.00	\$ -	\$ -	\$ -	\$ -	\$ 1,000.00
01-2222-210-00	Social Security	\$ 4,810.00	\$ 4,810.00	\$ 4,422.29	\$ 4,422.29	\$ -	\$ 4,422.29	\$ 387.71
01-2222-220-00	Retirement	\$ 6,197.00	\$ 6,197.00	\$ 5,669.32	\$ 5,669.32	\$ -	\$ 5,669.32	\$ 527.68
01-2222-290-00	Other Emp Bene	\$ 160.00	\$ 160.00	\$ 139.46	\$ 139.46	\$ -	\$ 139.46	\$ 20.54
01-2222-318-00	L.d. Consortium	\$ 35,000.00	\$ 35,000.00	\$ 46,000.00	\$ 46,000.00	\$ -	\$ 46,000.00	\$ (11,000.00)
01-2222-410-00	Supplies	\$ 2,000.00	\$ 2,000.00	\$ 4,308.55	\$ 4,308.55	\$ 449.87	\$ 4,758.42	\$ (2,758.42)
01-2222-430-00	Library Books	\$ 15,000.00	\$ 15,000.00	\$ 10,509.17	\$ 10,509.17	\$ 5,860.48	\$ 16,369.65	\$ (1,369.65)
01-2222-440-00	Periodicals	\$ 1,200.00	\$ 1,200.00	\$ 27.00	\$ 27.00	\$ 108.00	\$ 135.00	\$ 1,065.00
01-2222-450-00	A-v Materials	\$ 2,500.00	\$ 2,500.00	\$ -	\$ -	\$ 371.00	\$ 371.00	\$ 2,129.00
01-2222-460-00	Software	\$ 3,600.00	\$ 3,600.00	\$ -	\$ -	\$ -	\$ -	\$ 3,600.00
01-2222-530-00	Furn And Equip	\$ 1,000.00	\$ 1,000.00	\$ 567.71	\$ 567.71	\$ 662.99	\$ 1,230.70	\$ (230.70)
01-2222-670-00	Travel	\$ 500.00	\$ 500.00	\$ -	\$ -	\$ -	\$ -	\$ 500.00
01-2222-690-00	SCHOOL LIBRA	\$ 500.00	\$ 500.00	\$ -	\$ -	\$ -	\$ -	\$ 500.00
<b>Subtotal</b>		<b>\$ 137,207.00</b>	<b>\$ 137,207.00</b>	<b>\$ 129,451.00</b>	<b>\$ 129,451.00</b>	<b>\$ 7,452.34</b>	<b>\$ 136,903.34</b>	<b>\$ 303.66</b>

Primary Sort Element	Secondary Sort Element
01	Function:2310 - BOARD OF EDUCATION

Account Code	Description	Adopted Budget	Current Budget	Budget Actuals	YTD Actuals	Encumbrance	Projected	YTD Available
01-2310-315-00	Accounting/Audit	\$ -	\$ -	\$ 7,735.90	\$ 7,735.90	\$ -	\$ 7,735.90	\$ (7,735.90)
01-2310-317-00	Legal Services	\$ 8,000.00	\$ 8,000.00	\$ 6,490.39	\$ 6,490.39	\$ -	\$ 6,490.39	\$ 1,509.61
01-2310-350-00	Adv And Print	\$ 8,500.00	\$ 8,500.00	\$ 1,031.95	\$ 1,031.95	\$ -	\$ 1,031.95	\$ 7,468.05
01-2310-410-00	Supplies	\$ 3,500.00	\$ 3,500.00	\$ 1,287.87	\$ 1,287.87	\$ -	\$ 1,287.87	\$ 2,212.13
01-2310-460-00	BOARD OF EDL	\$ 2,500.00	\$ 2,500.00	\$ 1,500.00	\$ 1,500.00	\$ -	\$ 1,500.00	\$ 1,000.00
01-2310-530-00	Furniture and Eq	\$ -	\$ -	\$ 1,149.94	\$ 1,149.94	\$ -	\$ 1,149.94	\$ (1,149.94)
01-2310-630-00	Dues And Fees	\$ 9,500.00	\$ 9,500.00	\$ 87,164.70	\$ 87,164.70	\$ -	\$ 87,164.70	\$ (77,664.70)
01-2310-642-00	Fidelity Bon Pren	\$ 100.00	\$ 100.00	\$ -	\$ -	\$ -	\$ -	\$ 100.00
01-2310-670-00	Travel	\$ 10,000.00	\$ 10,000.00	\$ 2,475.46	\$ 2,475.46	\$ -	\$ 2,475.46	\$ 7,524.54
<b>Subtotal</b>		<b>\$ 42,100.00</b>	<b>\$ 42,100.00</b>	<b>\$ 108,836.21</b>	<b>\$ 108,836.21</b>	<b>\$ -</b>	<b>\$ 108,836.21</b>	<b>\$ (66,736.21)</b>

Primary Sort Element	Secondary Sort Element
01	Function:2320 - EXECUTIVE ADMINISTRATION SERVICES

Account Code	Description	Adopted Budget	Current Budget	Budget Actuals	YTD Actuals	Encumbrance	Projected	YTD Available
01-2320-105-00	Salary-supt	\$ 130,000.00	\$ 130,000.00	\$ 119,583.30	\$ 119,583.30	\$ -	\$ 119,583.30	\$ 10,416.70
01-2320-140-00	Salary-clerks	\$ 50,660.00	\$ 50,660.00	\$ 46,255.73	\$ 46,255.73	\$ -	\$ 46,255.73	\$ 4,404.27
01-2320-145-00	Overtime Classif	\$ 9,000.00	\$ 9,000.00	\$ 8,257.44	\$ 8,257.44	\$ -	\$ 8,257.44	\$ 742.56
01-2320-210-00	Social Security	\$ 14,400.00	\$ 14,400.00	\$ 12,792.54	\$ 12,792.54	\$ -	\$ 12,792.54	\$ 1,607.46
01-2320-220-00	Retirement	\$ 18,750.00	\$ 18,750.00	\$ 16,974.30	\$ 16,974.30	\$ -	\$ 16,974.30	\$ 1,775.70
01-2320-230-00	Health Ins	\$ 50,920.00	\$ 50,920.00	\$ 45,185.42	\$ 45,185.42	\$ -	\$ 45,185.42	\$ 5,734.58
01-2320-231-00	Health Ins - Dedi	\$ 2,700.00	\$ 2,700.00	\$ -	\$ -	\$ -	\$ -	\$ 2,700.00
01-2320-290-00	Other Emp Bene	\$ 455.00	\$ 455.00	\$ 1,187.76	\$ 1,187.76	\$ -	\$ 1,187.76	\$ (732.76)
01-2320-350-00	Advertising & Pri	\$ 3,000.00	\$ 3,000.00	\$ 1,406.66	\$ 1,406.66	\$ -	\$ 1,406.66	\$ 1,593.34
01-2320-410-00	Supplies	\$ 1,000.00	\$ 1,000.00	\$ 788.51	\$ 788.51	\$ -	\$ 788.51	\$ 211.49
01-2320-530-00	Furn. & Equip.	\$ 1,000.00	\$ 1,000.00	\$ -	\$ -	\$ -	\$ -	\$ 1,000.00
01-2320-560-00	Computer	\$ -	\$ -	\$ 150.00	\$ 150.00	\$ -	\$ 150.00	\$ (150.00)
01-2320-630-00	Dues And Fees	\$ 2,000.00	\$ 2,000.00	\$ 4,248.00	\$ 4,248.00	\$ -	\$ 4,248.00	\$ (2,248.00)
01-2320-670-00	Travel	\$ 5,000.00	\$ 5,000.00	\$ 3,582.48	\$ 3,582.48	\$ -	\$ 3,582.48	\$ 1,417.52
01-2320-690-00	EXECUTIVE AD	\$ 1,000.00	\$ 1,000.00	\$ 163.66	\$ 163.66	\$ -	\$ 163.66	\$ 836.34
<b>Subtotal</b>		<b>\$ 289,885.00</b>	<b>\$ 289,885.00</b>	<b>\$ 260,575.80</b>	<b>\$ 260,575.80</b>	<b>\$ -</b>	<b>\$ 260,575.80</b>	<b>\$ 29,309.20</b>

Cycle: FY15-16; Begin Date: 9/1/2015; End Date: 7/12/2016; Primary Sort Element: Fund; Secondary Sort Element: Function; Account List: ((Function) Between '1000' AND '9000') AND ((Fund) = '01') AND ((Object) Between '000' AND '755')

Primary Sort Element	Secondary Sort Element
01	Function:2410 - OFFICE OF THE PRINCIPAL

Account Code	Description	Adopted Budget	Current Budget	Budget Actuals	YTD Actuals	Encumbrance	Projected	YTD Available
01-2410-110-00	Salary-principal-	\$ 158,000.00	\$ 158,000.00	\$ 144,833.26	\$ 144,833.26	\$ -	\$ 144,833.26	\$ 13,166.74
01-2410-120-00	Substitutes	\$ 1,000.00	\$ 1,000.00	\$ 1,706.22	\$ 1,706.22	\$ -	\$ 1,706.22	\$ (706.22)
01-2410-140-00	Sal-clerk	\$ 57,500.00	\$ 57,500.00	\$ 49,691.42	\$ 49,691.42	\$ -	\$ 49,691.42	\$ 7,808.58
01-2410-145-00	Overtime Classif	\$ 2,000.00	\$ 2,000.00	\$ 2,303.26	\$ 2,303.26	\$ -	\$ 2,303.26	\$ (303.26)
01-2410-210-00	Social Security	\$ 16,682.00	\$ 16,682.00	\$ 14,656.71	\$ 14,656.71	\$ -	\$ 14,656.71	\$ 2,025.29
01-2410-220-00	Retirement	\$ 21,500.00	\$ 21,500.00	\$ 19,546.55	\$ 19,546.55	\$ -	\$ 19,546.55	\$ 1,953.45
01-2410-230-00	Health Ins	\$ 53,990.00	\$ 53,990.00	\$ 49,527.76	\$ 49,527.76	\$ -	\$ 49,527.76	\$ 4,462.24
01-2410-231-00	Health Ins - Dedi	\$ 4,950.00	\$ 4,950.00	\$ -	\$ -	\$ -	\$ -	\$ 4,950.00
01-2410-290-00	Other Emp Bene	\$ 540.00	\$ 540.00	\$ 493.85	\$ 493.85	\$ -	\$ 493.85	\$ 46.15
01-2410-319-00	Repairs	\$ 550.00	\$ 550.00	\$ -	\$ -	\$ -	\$ -	\$ 550.00
01-2410-410-00	Supplies	\$ 4,000.00	\$ 4,000.00	\$ 1,914.63	\$ 1,914.63	\$ -	\$ 1,914.63	\$ 2,085.37
01-2410-410-20	Supplies	\$ -	\$ -	\$ 30.75	\$ 30.75	\$ -	\$ 30.75	\$ (30.75)
01-2410-460-00	Software	\$ 1,500.00	\$ 1,500.00	\$ -	\$ -	\$ -	\$ -	\$ 1,500.00
01-2410-530-00	Furn And Equip	\$ 2,500.00	\$ 2,500.00	\$ -	\$ -	\$ -	\$ -	\$ 2,500.00
01-2410-560-00	Computer	\$ 1,200.00	\$ 1,200.00	\$ -	\$ -	\$ -	\$ -	\$ 1,200.00
01-2410-630-00	Dues & Fees	\$ 1,500.00	\$ 1,500.00	\$ 818.00	\$ 818.00	\$ -	\$ 818.00	\$ 682.00
01-2410-630-10	OFFICE OF THE	\$ -	\$ -	\$ 235.00	\$ 235.00	\$ -	\$ 235.00	\$ (235.00)
01-2410-670-00	Travel	\$ 6,000.00	\$ 6,000.00	\$ 1,033.79	\$ 1,033.79	\$ -	\$ 1,033.79	\$ 4,966.21
01-2410-670-10	Travel	\$ -	\$ -	\$ 127.70	\$ 127.70	\$ -	\$ 127.70	\$ (127.70)
01-2410-690-00	All Other	\$ 3,000.00	\$ 3,000.00	\$ 135.87	\$ 135.87	\$ -	\$ 135.87	\$ 2,864.13
<b>Subtotal</b>		<b>\$ 336,412.00</b>	<b>\$ 336,412.00</b>	<b>\$ 287,054.77</b>	<b>\$ 287,054.77</b>	<b>\$ -</b>	<b>\$ 287,054.77</b>	<b>\$ 49,357.23</b>

Primary Sort Element	Secondary Sort Element
01	Function:2510 - SUPPORT SERVICES-BUSINESS

Account Code	Description	Adopted Budget	Current Budget	Budget Actuals	YTD Actuals	Encumbrance	Projected	YTD Available
01-2510-315-00	Accounting & Au	\$ 8,000.00	\$ 8,000.00	\$ -	\$ -	\$ -	\$ -	\$ 8,000.00
01-2510-316-00	Business Office I	\$ 32,000.00	\$ 32,000.00	\$ 10,062.96	\$ 10,062.96	\$ -	\$ 10,062.96	\$ 21,937.04
01-2510-319-00	Purch Prof Tech	\$ 60,000.00	\$ 60,000.00	\$ 37,487.33	\$ 37,487.33	\$ -	\$ 37,487.33	\$ 22,512.67
01-2510-327-00	Rent-leases	\$ 12,000.00	\$ 12,000.00	\$ 45,188.32	\$ 45,188.32	\$ -	\$ 45,188.32	\$ (33,188.32)
01-2510-327-10	Copies-Elem	\$ -	\$ -	\$ 247.97	\$ 247.97	\$ -	\$ 247.97	\$ (247.97)
01-2510-327-20	Copies-HS	\$ -	\$ -	\$ 517.94	\$ 517.94	\$ -	\$ 517.94	\$ (517.94)
01-2510-336-00	SUPPORT SER	\$ 1,000.00	\$ 1,000.00	\$ 2,059.73	\$ 2,059.73	\$ -	\$ 2,059.73	\$ (1,059.73)
01-2510-350-00	Advertising/printi	\$ 500.00	\$ 500.00	\$ 120.80	\$ 120.80	\$ -	\$ 120.80	\$ 379.20
01-2510-381-00	SUPPORT SER	\$ 5,000.00	\$ 5,000.00	\$ 362.31	\$ 362.31	\$ -	\$ 362.31	\$ 4,637.69
01-2510-382-00	Telephone	\$ 15,000.00	\$ 15,000.00	\$ 11,654.38	\$ 11,654.38	\$ -	\$ 11,654.38	\$ 3,345.62
01-2510-383-00	Internet	\$ 10,000.00	\$ 10,000.00	\$ 147.09	\$ 147.09	\$ -	\$ 147.09	\$ 9,852.91
01-2510-410-00	Supplies	\$ 4,000.00	\$ 4,000.00	\$ 1,216.27	\$ 1,216.27	\$ -	\$ 1,216.27	\$ 2,783.73
01-2510-520-00	Bldg Improve	\$ 229,500.00	\$ 229,500.00	\$ 9,600.00	\$ 9,600.00	\$ -	\$ 9,600.00	\$ 219,900.00
01-2510-530-00	Furn And Equip	\$ 3,000.00	\$ 3,000.00	\$ 2,288.13	\$ 2,288.13	\$ -	\$ 2,288.13	\$ 711.87
01-2510-630-00	Dues & Fees	\$ -	\$ -	\$ 99.00	\$ 99.00	\$ -	\$ 99.00	\$ (99.00)
01-2510-690-00	Audit - All Other	\$ -	\$ -	\$ 1,200.00	\$ 1,200.00	\$ -	\$ 1,200.00	\$ (1,200.00)
<b>Subtotal</b>		<b>\$ 380,000.00</b>	<b>\$ 380,000.00</b>	<b>\$ 122,252.23</b>	<b>\$ 122,252.23</b>	<b>\$ -</b>	<b>\$ 122,252.23</b>	<b>\$ 257,747.77</b>

Primary Sort Element	Secondary Sort Element
01	Function:2520 - VEHICLE ACQUISITION AND MAINTENANCE OTHER THAN PUPIL TRANSPORTATION

Account Code	Description	Adopted Budget	Current Budget	Budget Actuals	YTD Actuals	Encumbrance	Projected	YTD Available
01-2520-334-00	Maintenance	\$ 1,500.00	\$ 1,500.00	\$ -	\$ -	\$ -	\$ -	\$ 1,500.00
01-2520-336-00	Gas And Oil (Nc	\$ 3,000.00	\$ 3,000.00	\$ 13.58	\$ 13.58	\$ -	\$ 13.58	\$ 2,986.42
01-2520-550-00	Vehicle Purchas	\$ 25,000.00	\$ 25,000.00	\$ -	\$ -	\$ -	\$ -	\$ 25,000.00
<b>Subtotal</b>		<b>\$ 29,500.00</b>	<b>\$ 29,500.00</b>	<b>\$ 13.58</b>	<b>\$ 13.58</b>	<b>\$ -</b>	<b>\$ 13.58</b>	<b>\$ 29,486.42</b>

Cycle: FY15-16; Begin Date: 9/1/2015; End Date: 7/12/2016; Primary Sort Element: Fund; Secondary Sort Element: Function; Account List: ((Function) Between '1000' AND '9000') AND ((Fund) = '01') AND ((Object) Between '000' AND '755')

Primary Sort Element	Secondary Sort Element
01	Function:2610 - OPERATION OF PLANT

Account Code	Description	Adopted Budget	Current Budget	Budget Actuals	YTD Actuals	Encumbrance	Projected	YTD Available
01-2610-120-00	Substitutes	\$ 8,000.00	\$ 8,000.00	\$ 8,402.63	\$ 8,402.63	\$ -	\$ 8,402.63	\$ (402.63)
01-2610-140-00	Sal-custodian	\$ 203,525.00	\$ 203,525.00	\$ 182,976.91	\$ 182,976.91	\$ -	\$ 182,976.91	\$ 20,548.09
01-2610-145-00	Overtime Classif	\$ 3,000.00	\$ 3,000.00	\$ 1,078.29	\$ 1,078.29	\$ -	\$ 1,078.29	\$ 1,921.71
01-2610-210-00	Social Security	\$ 16,050.00	\$ 16,050.00	\$ 14,350.62	\$ 14,350.62	\$ -	\$ 14,350.62	\$ 1,699.38
01-2610-220-00	Retirement	\$ 20,726.00	\$ 20,726.00	\$ 18,364.10	\$ 18,364.10	\$ -	\$ 18,364.10	\$ 2,361.90
01-2610-230-00	Health Ins	\$ 76,840.00	\$ 76,840.00	\$ 66,484.25	\$ 66,484.25	\$ -	\$ 66,484.25	\$ 10,355.75
01-2610-231-00	Health Ins - Dedi	\$ 4,450.00	\$ 4,450.00	\$ -	\$ -	\$ -	\$ -	\$ 4,450.00
01-2610-290-00	Other Emp Bene	\$ 510.00	\$ 510.00	\$ 676.06	\$ 676.06	\$ -	\$ 676.06	\$ (166.06)
01-2610-318-00	Repairman	\$ 35,000.00	\$ 35,000.00	\$ 49,596.33	\$ 49,596.33	\$ -	\$ 49,596.33	\$ (14,596.33)
01-2610-320-00	Property Service	\$ 500.00	\$ 500.00	\$ 440.00	\$ 440.00	\$ -	\$ 440.00	\$ 60.00
01-2610-321-00	Fuel	\$ 50,000.00	\$ 50,000.00	\$ 24,031.76	\$ 24,031.76	\$ -	\$ 24,031.76	\$ 25,968.24
01-2610-322-00	Electricity	\$ 124,250.00	\$ 124,250.00	\$ 108,251.05	\$ 108,251.05	\$ -	\$ 108,251.05	\$ 15,998.95
01-2610-323-00	Water And Sewe	\$ 33,000.00	\$ 33,000.00	\$ 32,033.54	\$ 32,033.54	\$ -	\$ 32,033.54	\$ 966.46
01-2610-327-00	Rentals and Lea	\$ 3,500.00	\$ 3,500.00	\$ 1,355.00	\$ 1,355.00	\$ -	\$ 1,355.00	\$ 2,145.00
01-2610-328-00	Insurance	\$ 138,000.00	\$ 138,000.00	\$ 129,155.12	\$ 129,155.12	\$ -	\$ 129,155.12	\$ 8,844.88
01-2610-329-00	Other Property S	\$ 500.00	\$ 500.00	\$ 64.70	\$ 64.70	\$ 23.50	\$ 88.20	\$ 411.80
01-2610-338-00	Repairs	\$ -	\$ -	\$ 503.05	\$ 503.05	\$ -	\$ 503.05	\$ (503.05)
01-2610-382-00	OPERATION OI	\$ 3,000.00	\$ 3,000.00	\$ 208.77	\$ 208.77	\$ -	\$ 208.77	\$ 2,791.23
01-2610-410-00	Supplies	\$ 60,000.00	\$ 60,000.00	\$ 46,162.69	\$ 46,162.69	\$ 13.90	\$ 46,176.59	\$ 13,823.41
01-2610-530-00	Furniture & Equip	\$ 25,000.00	\$ 25,000.00	\$ 5,429.48	\$ 5,429.48	\$ -	\$ 5,429.48	\$ 19,570.52
01-2610-670-00	Travel	\$ 500.00	\$ 500.00	\$ -	\$ -	\$ -	\$ -	\$ 500.00
01-2610-690-00	Training and Tra	\$ 500.00	\$ 500.00	\$ 400.00	\$ 400.00	\$ -	\$ 400.00	\$ 100.00
<b>Subtotal</b>		<b>\$ 806,851.00</b>	<b>\$ 806,851.00</b>	<b>\$ 689,964.35</b>	<b>\$ 689,964.35</b>	<b>\$ 37.40</b>	<b>\$ 690,001.75</b>	<b>\$ 116,849.25</b>

Primary Sort Element	Secondary Sort Element
01	Function:2750 - PUPIL TRANSPORTATION

Account Code	Description	Adopted Budget	Current Budget	Budget Actuals	YTD Actuals	Encumbrance	Projected	YTD Available
01-2750-120-00	Substitutes	\$ 15,000.00	\$ 15,000.00	\$ 20,061.43	\$ 20,061.43	\$ -	\$ 20,061.43	\$ (5,061.43)
01-2750-140-00	Sal-bus Driver	\$ 162,650.00	\$ 162,650.00	\$ 135,881.86	\$ 135,881.86	\$ -	\$ 135,881.86	\$ 26,768.14
01-2750-141-00	Activity Driving	\$ 22,000.00	\$ 22,000.00	\$ 17,624.21	\$ 17,624.21	\$ -	\$ 17,624.21	\$ 4,375.79
01-2750-160-00	Poverty - Town C	\$ 7,120.00	\$ 7,120.00	\$ 6,740.00	\$ 6,740.00	\$ -	\$ 6,740.00	\$ 380.00
01-2750-210-00	Social Security	\$ 15,850.00	\$ 15,850.00	\$ 13,668.62	\$ 13,668.62	\$ -	\$ 13,668.62	\$ 2,181.38
01-2750-220-00	Retirement	\$ 17,200.00	\$ 17,200.00	\$ 14,766.52	\$ 14,766.52	\$ -	\$ 14,766.52	\$ 2,433.48
01-2750-230-00	Health Ins	\$ 6,215.00	\$ 6,215.00	\$ 6,027.98	\$ 6,027.98	\$ -	\$ 6,027.98	\$ 187.02
01-2750-231-00	Health Ins - Dedi	\$ 450.00	\$ 450.00	\$ -	\$ -	\$ -	\$ -	\$ 450.00
01-2750-290-00	Other Emp Bene	\$ 1,500.00	\$ 1,500.00	\$ 1,433.78	\$ 1,433.78	\$ -	\$ 1,433.78	\$ 66.22
01-2750-336-00	Gas And Oil (Stu	\$ 110,000.00	\$ 110,000.00	\$ 40,661.18	\$ 40,661.18	\$ -	\$ 40,661.18	\$ 69,338.82
01-2750-336-10	PUPIL TRANSP	\$ -	\$ -	\$ 68.45	\$ 68.45	\$ -	\$ 68.45	\$ (68.45)
01-2750-337-00	Tires And Parts	\$ 36,000.00	\$ 36,000.00	\$ 25,318.30	\$ 25,318.30	\$ 88.92	\$ 25,407.22	\$ 10,592.78
01-2750-338-00	Bus Repairs	\$ 20,000.00	\$ 20,000.00	\$ 6,300.63	\$ 6,300.63	\$ -	\$ 6,300.63	\$ 13,699.37
01-2750-342-00	Telephone	\$ 500.00	\$ 500.00	\$ -	\$ -	\$ -	\$ -	\$ 500.00
01-2750-382-00	PUPIL TRANSP	\$ 100.00	\$ 100.00	\$ 53.77	\$ 53.77	\$ -	\$ 53.77	\$ 46.23
01-2750-410-00	Pupil Trans Supp	\$ 2,500.00	\$ 2,500.00	\$ 2,295.03	\$ 2,295.03	\$ 207.12	\$ 2,502.15	\$ (2.15)
01-2750-460-00	PUPIL TRANSP	\$ -	\$ -	\$ 741.00	\$ 741.00	\$ 75.00	\$ 816.00	\$ (816.00)
01-2750-465-00	PUPIL TRANSP	\$ 1,000.00	\$ 1,000.00	\$ 5,285.85	\$ 5,285.85	\$ -	\$ 5,285.85	\$ (4,285.85)
01-2750-540-00	Bus Acquisition	\$ 180,000.00	\$ 180,000.00	\$ -	\$ -	\$ -	\$ -	\$ 180,000.00
01-2750-630-00	PUPIL TRANSP	\$ 500.00	\$ 500.00	\$ 147.00	\$ 147.00	\$ -	\$ 147.00	\$ 353.00
01-2750-670-00	Travel	\$ 500.00	\$ 500.00	\$ 104.64	\$ 104.64	\$ -	\$ 104.64	\$ 395.36
01-2750-690-00	Other Misc	\$ 10,000.00	\$ 10,000.00	\$ 3,486.37	\$ 3,486.37	\$ 316.28	\$ 3,802.65	\$ 6,197.35
<b>Subtotal</b>		<b>\$ 609,085.00</b>	<b>\$ 609,085.00</b>	<b>\$ 300,666.62</b>	<b>\$ 300,666.62</b>	<b>\$ 687.32</b>	<b>\$ 301,353.94</b>	<b>\$ 307,731.06</b>

Primary Sort Element	Secondary Sort Element
01	Function:2760 - SCHOOL AGE SPECIAL EDUCATION PUPIL TRANSPORTATION

Cycle: FY15-16; Begin Date: 9/1/2015; End Date: 7/12/2016; Primary Sort Element: Fund; Secondary Sort Element: Function; Account List: ((Function) Between '1000' AND '9000') AND ((Fund) = '01') AND ((Object) Between '000' AND '755')

Account Code	Description	Adopted Budge	Current Budget	Actuals	YTD Actuals	Encumbrance	Projected	YTD Available
01-2760-140-00	Salary-sped Driv	\$ 12,500.00	\$ 12,500.00	\$ 4,692.77	\$ 4,692.77	\$ -	\$ 4,692.77	\$ 7,807.23
01-2760-210-00	Sped Social Sec	\$ 960.00	\$ 960.00	\$ 358.68	\$ 358.68	\$ -	\$ 358.68	\$ 601.32
01-2760-220-00	Sped Retirement	\$ 1,235.00	\$ 1,235.00	\$ 378.75	\$ 378.75	\$ -	\$ 378.75	\$ 856.25
01-2760-230-00	Health Ins	\$ -	\$ -	\$ 6.17	\$ 6.17	\$ -	\$ 6.17	\$ (6.17)
01-2760-336-00	SCHOOL AGE S	\$ 1,000.00	\$ 1,000.00	\$ 633.88	\$ 633.88	\$ -	\$ 633.88	\$ 366.12
<b>Subtotal</b>		<b>\$ 15,695.00</b>	<b>\$ 15,695.00</b>	<b>\$ 6,070.25</b>	<b>\$ 6,070.25</b>	<b>\$ -</b>	<b>\$ 6,070.25</b>	<b>\$ 9,624.75</b>

Primary Sort El	Secondary Sort Element
01	Function:4202 - TITLE I-INSTRUCTIONAL

Account Code	Description	Adopted Budge	Current Budget	Actuals	YTD Actuals	Encumbrance	Projected	YTD Available
01-4202-110-00	Title I - Salary	\$ 62,145.00	\$ 62,145.00	\$ 56,963.94	\$ 56,963.94	\$ -	\$ 56,963.94	\$ 5,181.06
01-4202-120-00	Title I - Substitut	\$ 2,500.00	\$ 2,500.00	\$ 3,015.63	\$ 3,015.63	\$ -	\$ 3,015.63	\$ (515.63)
01-4202-130-00	Staff Developme	\$ 2,546.00	\$ 2,546.00	\$ -	\$ -	\$ -	\$ -	\$ 2,546.00
01-4202-210-00	Title I - Social Se	\$ 4,851.00	\$ 4,851.00	\$ 4,474.37	\$ 4,474.37	\$ -	\$ 4,474.37	\$ 376.63
01-4202-220-00	Title I - Retireme	\$ 6,264.00	\$ 6,264.00	\$ 5,626.82	\$ 5,626.82	\$ -	\$ 5,626.82	\$ 637.18
01-4202-230-00	Title I - Health In	\$ 16,975.00	\$ 16,975.00	\$ 15,558.51	\$ 15,558.51	\$ -	\$ 15,558.51	\$ 1,416.49
01-4202-231-00	Title I - Health In	\$ 900.00	\$ 900.00	\$ -	\$ -	\$ -	\$ -	\$ 900.00
01-4202-290-00	Title I - Income F	\$ 155.00	\$ 155.00	\$ 144.65	\$ 144.65	\$ -	\$ 144.65	\$ 10.35
01-4202-410-00	Title I - Supplies	\$ 3,500.00	\$ 3,500.00	\$ 2,455.55	\$ 2,455.55	\$ -	\$ 2,455.55	\$ 1,044.45
01-4202-420-00	Title I - Textbook	\$ 750.00	\$ 750.00	\$ 2,117.27	\$ 2,117.27	\$ -	\$ 2,117.27	\$ (1,367.27)
01-4202-670-00	Title I - Travel	\$ 2,000.00	\$ 2,000.00	\$ 38.21	\$ 38.21	\$ -	\$ 38.21	\$ 1,961.79
<b>Subtotal</b>		<b>\$ 102,586.00</b>	<b>\$ 102,586.00</b>	<b>\$ 90,394.95</b>	<b>\$ 90,394.95</b>	<b>\$ -</b>	<b>\$ 90,394.95</b>	<b>\$ 12,191.05</b>

Primary Sort El	Secondary Sort Element
01	Function:4213 - TITLE I - SCHOOL IMPROVEMENT

Account Code	Description	Adopted Budge	Current Budget	Actuals	YTD Actuals	Encumbrance	Projected	YTD Available
01-4213-690-00	Title I Acct.- Oth	\$ 24,000.00	\$ 24,000.00	\$ 30.00	\$ 30.00	\$ -	\$ 30.00	\$ 23,970.00
<b>Subtotal</b>		<b>\$ 24,000.00</b>	<b>\$ 24,000.00</b>	<b>\$ 30.00</b>	<b>\$ 30.00</b>	<b>\$ -</b>	<b>\$ 30.00</b>	<b>\$ 23,970.00</b>

Primary Sort El	Secondary Sort Element
01	Function:4404 - IDEA PART B (611) BASE ALLOCATION - BIRTH THROUGH AGE FOUR

Account Code	Description	Adopted Budge	Current Budget	Actuals	YTD Actuals	Encumbrance	Projected	YTD Available
01-4404-300-00	IDEA PART B (6	\$ 50,500.00	\$ 50,500.00	\$ -	\$ -	\$ -	\$ -	\$ 50,500.00
<b>Subtotal</b>		<b>\$ 50,500.00</b>	<b>\$ 50,500.00</b>	<b>\$ -</b>	<b>\$ -</b>	<b>\$ -</b>	<b>\$ -</b>	<b>\$ 50,500.00</b>

Primary Sort El	Secondary Sort Element
01	Function:4406 - SPED IDEA PRESCHOOL

Account Code	Description	Adopted Budge	Current Budget	Actuals	YTD Actuals	Encumbrance	Projected	YTD Available
01-4406-300-00	SPED IDEA PRE	\$ 4,500.00	\$ 4,500.00	\$ -	\$ -	\$ -	\$ -	\$ 4,500.00
<b>Subtotal</b>		<b>\$ 4,500.00</b>	<b>\$ 4,500.00</b>	<b>\$ -</b>	<b>\$ -</b>	<b>\$ -</b>	<b>\$ -</b>	<b>\$ 4,500.00</b>

Primary Sort El	Secondary Sort Element
01	Function:4410 - IDEA ENROLLMENT/POVERTY (611)

Account Code	Description	Adopted Budge	Current Budget	Actuals	YTD Actuals	Encumbrance	Projected	YTD Available
01-4410-100-00	IDEA ENROLLM	\$ 73,000.00	\$ 73,000.00	\$ -	\$ -	\$ -	\$ -	\$ 73,000.00

Cycle: FY15-16; Begin Date: 9/1/2015; End Date: 7/12/2016; Primary Sort Element: Fund; Secondary Sort Element: Function; Account List: ((Function] Between '1000' AND '9000') AND ((Fund] = '01') AND ((Object] Between '000' AND '755')

01-4410-200-00( IDEA ENROLLM	\$	2,700.00	\$	2,700.00	\$	-	\$	-	\$	-	\$	2,700.00
<b>Subtotal</b>	<b>\$</b>	<b>75,700.00</b>	<b>\$</b>	<b>75,700.00</b>	<b>\$</b>	<b>-</b>	<b>\$</b>	<b>-</b>	<b>\$</b>	<b>-</b>	<b>\$</b>	<b>75,700.00</b>

<b>Primary Sort El</b>	<b>Secondary Sort Element</b>
01	Function:4990 - OTHER FEDERAL CATEGORICAL RECEIPTS

Account Code	Description	Adopted Budge	Current Budget	Actuals	YTD Actuals	Encumbrance	Projected	YTD Available
01-4990-410-00( OTHER FEDER)		\$ -	\$ -	\$ 147.05	\$ 147.05	\$ -	\$ 147.05	\$ (147.05)
<b>Subtotal</b>		<b>\$ -</b>	<b>\$ -</b>	<b>\$ 147.05</b>	<b>\$ 147.05</b>	<b>\$ -</b>	<b>\$ 147.05</b>	<b>\$ (147.05)</b>

<b>Primary Sort El</b>	<b>Secondary Sort Element</b>
01	Function:5000 - DEBT SERVICES

Account Code	Description	Adopted Budge	Current Budget	Actuals	YTD Actuals	Encumbrance	Projected	YTD Available
01-5000-610-00( Debt Service		\$ 100,000.00	\$ 100,000.00	\$ -	\$ -	\$ -	\$ -	\$ 100,000.00
<b>Subtotal</b>		<b>\$ 100,000.00</b>	<b>\$ 100,000.00</b>	<b>\$ -</b>	<b>\$ -</b>	<b>\$ -</b>	<b>\$ -</b>	<b>\$ 100,000.00</b>

<b>Primary Sort El</b>	<b>Secondary Sort Element</b>
01	Function:6000 - SUMMER SCHOOL

Account Code	Description	Adopted Budge	Current Budget	Actuals	YTD Actuals	Encumbrance	Projected	YTD Available
01-6000-110-00( Summer-dr.ed.		\$ 5,500.00	\$ 5,500.00	\$ -	\$ -	\$ -	\$ -	\$ 5,500.00
01-6000-210-00( Summer-dr.ed.		\$ 425.00	\$ 425.00	\$ -	\$ -	\$ -	\$ -	\$ 425.00
01-6000-220-00( Summer-dr.ed.-t		\$ 550.00	\$ 550.00	\$ -	\$ -	\$ -	\$ -	\$ 550.00
01-6000-336-00( Dr. Ed.-gas & Oil		\$ 750.00	\$ 750.00	\$ -	\$ -	\$ -	\$ -	\$ 750.00
01-6000-410-00( Dr. Ed.-supplies		\$ 50.00	\$ 50.00	\$ -	\$ -	\$ -	\$ -	\$ 50.00
01-6000-670-00( Dr. Ed.-travel		\$ 1,100.00	\$ 1,100.00	\$ -	\$ -	\$ -	\$ -	\$ 1,100.00
<b>Subtotal</b>		<b>\$ 8,375.00</b>	<b>\$ 8,375.00</b>	<b>\$ -</b>	<b>\$ -</b>	<b>\$ -</b>	<b>\$ -</b>	<b>\$ 8,375.00</b>

<b>Primary Sort El</b>	<b>Secondary Sort Element</b>
01	Function:7820 - VOCATIONAL EDUCATION

Account Code	Description	Adopted Budge	Current Budget	Actuals	YTD Actuals	Encumbrance	Projected	YTD Available
01-7820-110-00( Sal-ad Ed Voc E		\$ 600.00	\$ 600.00	\$ 550.00	\$ 550.00	\$ -	\$ 550.00	\$ 50.00
01-7820-210-00( Social Security		\$ 46.00	\$ 46.00	\$ 41.72	\$ 41.72	\$ -	\$ 41.72	\$ 4.28
01-7820-220-00( Retirement		\$ 60.00	\$ 60.00	\$ 54.34	\$ 54.34	\$ -	\$ 54.34	\$ 5.66
01-7820-230-00( Health		\$ 60.00	\$ 60.00	\$ -	\$ -	\$ -	\$ -	\$ 60.00
01-7820-290-00( Other Benefits		\$ 5.00	\$ 5.00	\$ -	\$ -	\$ -	\$ -	\$ 5.00
<b>Subtotal</b>		<b>\$ 771.00</b>	<b>\$ 771.00</b>	<b>\$ 646.06</b>	<b>\$ 646.06</b>	<b>\$ -</b>	<b>\$ 646.06</b>	<b>\$ 124.94</b>

<b>Primary Sort El</b>	<b>Secondary Sort Element</b>
01	Function:8000 - TRANSFERS (OUTGOING)

Account Code	Description	Adopted Budge	Current Budget	Actuals	YTD Actuals	Encumbrance	Projected	YTD Available
01-8000-700-00( TRANSFERS (O		\$ 250,000.00	\$ 250,000.00	\$ -	\$ -	\$ -	\$ -	\$ 250,000.00
01-8000-750-00( TRANSFERS (O		\$ 50,000.00	\$ 50,000.00	\$ -	\$ -	\$ -	\$ -	\$ 50,000.00
01-8000-752-00( Transfer-activity		\$ 50,000.00	\$ 50,000.00	\$ -	\$ -	\$ -	\$ -	\$ 50,000.00
<b>Subtotal</b>		<b>\$ 350,000.00</b>	<b>\$ 350,000.00</b>	<b>\$ -</b>	<b>\$ -</b>	<b>\$ -</b>	<b>\$ -</b>	<b>\$ 350,000.00</b>

<b>Primary Sort El</b>	<b>Secondary Sort Element</b>
01	Function:9000 - NON-PROGRAM EXPENDITURES

Cycle: FY15-16; Begin Date: 9/1/2015; End Date: 7/12/2016; Primary Sort Element: Fund; Secondary Sort Element: Function; Account List: ([Function] Between '1000' AND '9000') AND ([Fund] = '01') AND ([Object] Between '000' AND '755')

Account Code	Description	Adopted Budge	Current Budget	Budget Actuals	YTD Actuals	Encumbrance	Projected	YTD Available
01-9000-690-00	( Non-programme	\$ -	\$ -	\$ -	\$ -	\$ -	\$ -	\$ -
01-9000-752-00	( NON-PROGRAM	\$ -	\$ -	\$ (193,099.00)	\$ (193,099.00)	\$ -	\$ (193,099.00)	\$ 193,099.00
01-9000-755-00	( Transfer	\$ -	\$ -	\$ 235,000.00	\$ 235,000.00	\$ -	\$ 235,000.00	\$ (235,000.00)
<b>Subtotal</b>		<b>\$ -</b>	<b>\$ -</b>	<b>\$ 41,901.00</b>	<b>\$ 41,901.00</b>	<b>\$ -</b>	<b>\$ 41,901.00</b>	<b>\$ (41,901.00)</b>
<b>Total</b>		<b>\$ 8,425,000.00</b>	<b>\$ 8,425,000.00</b>	<b>\$ 6,446,104.41</b>	<b>\$ 6,446,104.41</b>	<b>\$ 54,057.29</b>	<b>\$ 6,500,161.70</b>	<b>\$ 1,924,838.30</b>
							<u>77%</u>	
						Proj. Budget to Date	92%	
						<b>Under (Over)</b>	<b>15%</b>	

FY15-16

Vendor Invoice Number: 06-27-2016

Item No.	Item Description	Account Code	Item Total
2	Amazon-The Art & Science of Teaching	01-2410-690-000	\$ 51.20
3	Transartic Inc-Air filters-Rex	01-2750-337-000	\$ 73.32
4	Wenger Corp-Brackets for stage platforms in Auditorium	01-2610-530-000	\$ 525.00
5	Red Lobster-Lefdal	01-2320-670-000	\$ 34.08
6	Amazon-Driver's Ed	01-1100-410-000	\$ 29.95
7	Amazon-Driver's Ed	01-1100-410-000	\$ 34.95
8	Amazon-Exercise Balls(4)-Lenners	01-1100-410-000	\$ 79.80
9	Amazon-Books-Class for Srs.-Herbert	01-1100-410-000	\$ 559.50
10	Amazon-Linksys AE1200-Ekberg	01-1100-410-000	\$ 79.92
11	Amazon-Vlasin Class	01-1100-410-000	\$ 81.74
12	Amazon-Vlasin-7 Habits/Teens	01-1100-410-000	\$ 372.60
13	STI Inc-GPS	01-2510-319-000	\$ 25.00
14	Hampton Inn in Hays, KS-Show Choir Trip to Branson	01-1100-670-000	\$ 562.80
15	Quill-Zenergy Ball Chairs (6)-Odens	01-1100-530-000	\$ 638.94
16	Office Max-Library Supplies-Burpo	01-2222-410-000	\$ 80.43
17	Office Max-Library Supplies-Burpo	01-2222-410-000	\$ 34.18
18	Office Max-Library Supplies-Burpo	01-2222-410-000	\$ 14.71
19	PayPal-New England Dance-(2)Books	01-1100-410-000	\$ 75.00
20	SitSpots-Fortkamp	01-1100-410-000	\$ 139.30
21	SitSpots-Liess	01-1100-410-000	\$ 25.85
22	NASSP-NHS Membership Dues-1 yr	01-1100-630-000	\$ 385.00
23	Casey's-Kearney-Fuel-Scheel	01-2410-670-000	\$ 62.99
24	Taco Bell-Scheel	01-2410-670-000	\$ 4.04
25	Amigos-Scheel	01-2410-670-000	\$ 9.16
26	Amazon-Motivating & Inspiring Teachers-Book	01-2410-690-000	\$ 14.67
27	Electronix Express-Science-Wilson	01-1100-410-000	\$ 256.20
28	WalMart-Hilker-4th grade	01-1100-410-000	\$ 95.61
29	ASCD-Membership-Scheel	01-2410-630-000	\$ 59.00
30	dynamism-3D Printer-Science-Wilson	01-1100-530-000	\$ 2,349.06
31	Amazon-Books (2) Hanna	01-2120-410-000	\$ 19.48
32	Amazon-Books (2) Hanna \$8.88 credit of one \$4.00	01-2120-410-000	\$ 4.88
33	Amazon-Book-Hanna	01-2120-410-000	\$ 4.00
34	Amazon-Book-Hanna	01-2120-410-000	\$ 8.72
35	Amazon-Book-Hanna	01-2120-410-000	\$ 19.95
36	Amazon-Book-Hanna	01-2120-410-000	\$ 7.95
37	Amazon-Books-Hanna	01-2120-410-000	\$ 94.78
38	Amazon-Books-Hanna	01-2120-410-000	\$ 97.87
39	Amazon-Book-Hanna	01-2120-410-000	\$ 4.00
40	Amazon-Book-Hanna	01-2120-410-000	\$ 4.00
41	Amazon-Book-Hanna	01-2120-410-000	\$ 4.00
42	Amazon-Book-Hanna	01-2120-410-000	\$ 4.00
43	Amazon-Book-Hanna	01-2120-410-000	\$ 4.00
44	Amazon-Books-Hanna	01-2120-410-000	\$ 16.00
45	Amazon-Book-Hanna	01-2120-410-000	\$ 8.52
46	NE Council of School Adm-Odens(yr)	01-2410-630-000	\$ 335.00
47	MPM School Supplies-Dannatt-3rd Grade	01-1100-410-000	\$ 341.28
48	AAA Foundation for Traffic Safety-Driver's Ed	01-1100-410-000	\$ 151.06
49	Electronix Express-Science-Wilson	01-1100-410-000	\$ 49.00
50	Amazon-Index Tabs-Central Supply	01-1100-410-000	\$ 9.34
51	Amazon-Mechanical Pencils-Central Supply	01-1100-410-000	\$ 10.99
52	Amazon-(8)Geometry Books-Schueler	01-1100-420-000	\$ 203.44
53	Lightspeed Technologies-Repair Microphone-Lakey	01-1200-410-000	\$ 197.00
54	STI Inc.-GPS Service	01-2510-319-000	\$ 25.00
55	SQ Flippin Sweet Burger-Scheel	01-2410-670-000	\$ 61.45
56	Sozo American Cuisine-Scheel	01-2410-670-000	\$ 49.75
57	Loves Country-Fuel-Scheel	01-2410-670-000	\$ 46.41
58	Activity	01-9000-752-000	\$ 5,463.68
	<b>US Bank Total</b>		<b>\$ 13,999.55</b>

Description	09 - Activity	Total
<b>Total Revenue</b>	\$ -	\$ -
9001 - CCHS Athletics	\$ 1,987.70	\$ 1,987.70
9102 - CCES Yearbook	\$ 2,078.21	\$ 2,078.21
9215 - Building Construction	\$ 1,557.00	\$ 1,557.00
9300 - Show Choir	\$ 3,499.85	\$ 3,499.85
9999 - Clearing	\$ 1,524.25	\$ 1,524.25
9000 - NON-PROGRAM EXPENDITURES	\$ (20,706.60)	\$ (20,706.60)
9002 - CCHS Softball	\$ 2,883.35	\$ 2,883.35
9003 - CCHS Football	\$ 7,863.70	\$ 7,863.70
9006 - CCHS BB- Girls	\$ 2,301.45	\$ 2,301.45
9007 - CCHS BB- Boys	\$ 3,784.12	\$ 3,784.12
9008 - CCHS Wrestling	\$ 19,476.38	\$ 19,476.38
9009 - CCHS Track-Girls	\$ 3,313.51	\$ 3,313.51
9010 - CCHS Track-Boys	\$ 3,167.49	\$ 3,167.49
9011 - CCHS Golf	\$ 759.10	\$ 759.10
9013 - JH Football	\$ 278.25	\$ 278.25
9014 - JH Volleyball	\$ 1,858.82	\$ 1,858.82
9015 - JH BB-Girls	\$ 720.00	\$ 720.00
9016 - JH BB-Boys	\$ 1,080.00	\$ 1,080.00
9017 - JH Wrestling	\$ 285.00	\$ 285.00
9018 - JH Track-Girls	\$ 315.44	\$ 315.44
9019 - JH Track-Boys	\$ 260.46	\$ 260.46
9020 - PE Uniform Resale	\$ 3,558.30	\$ 3,558.30
9100 - Cheerleaders	\$ 2,253.02	\$ 2,253.02
9101 - CCHS Annual	\$ 824.25	\$ 824.25
9103 - Thespians	\$ 1,880.23	\$ 1,880.23
9104 - Student Council	\$ 1,677.14	\$ 1,677.14
9105 - Exploring Free Enterprise	\$ 305.00	\$ 305.00
9106 - CCS Flower Fund	\$ 66.95	\$ 66.95
9108 - Electric Car Project	\$ 1,313.79	\$ 1,313.79
9200 - FBLA	\$ 1,993.00	\$ 1,993.00
9205 - FCCLA	\$ 5,819.27	\$ 5,819.27
9203 - AD Savings	\$ 174.53	\$ 174.53
9206 - FCCLA-Sponsor	\$ 1,688.23	\$ 1,688.23
9207 - Pro-Start	\$ 267.74	\$ 267.74
9210 - FFA	\$ 25,680.56	\$ 25,680.56
9211 - FFA-Sponsors	\$ 289.82	\$ 289.82
9212 - FFA Farm	\$ 4,290.03	\$ 4,290.03
9214 - IA Resale	\$ 5,995.44	\$ 5,995.44
9301 - Show Choir Outfits	\$ 12.31	\$ 12.31
9305 - Band	\$ 8,256.60	\$ 8,256.60
9402 - Elementary Activity Fund	\$ 472.82	\$ 472.82
9407 - Lock Resale	\$ 50.00	\$ 50.00
9410 - Milk Vending	\$ 1,720.38	\$ 1,720.38
9505 - Class of 2016	\$ 2,252.45	\$ 2,252.45
<b>Total Expenditure</b>	\$ 109,129.34	\$ 109,129.34
9001 - CCHS Athletics	\$ 7,764.55	\$ 7,764.55
9004 - CCHS Volleyball	\$ 1,087.02	\$ 1,087.02
9005 - CCHS X-County	\$ 422.87	\$ 422.87
9006 - CCHS Basketball-Girls	\$ 4,807.71	\$ 4,807.71
9007 - CCHS Basketball-Boys	\$ 3,606.90	\$ 3,606.90
9008 - CCHS Wrestling	\$ 8,503.32	\$ 8,503.32
9009 - CCHS Track-Girls	\$ 1,375.40	\$ 1,375.40
9010 - CCHS Track-Boys	\$ 1,375.41	\$ 1,375.41
9011 - CCHS Golf	\$ 5,349.66	\$ 5,349.66
9012 - CCES Athletics	\$ 463.62	\$ 463.62
9018 - JH Track-Girls	\$ 75.00	\$ 75.00
9019 - JH Track-Boys	\$ 75.00	\$ 75.00
9020 - PE Uniform Resale	\$ 120.00	\$ 120.00
9021 - HS Milner Benefit Fund	\$ 250.00	\$ 250.00
9022 - Speed Camp	\$ 156.00	\$ 156.00
9023 - AD Savings	\$ 8,111.05	\$ 8,111.05
9100 - Cheerleaders	\$ 4,644.93	\$ 4,644.93
9101 - CCHS Annual	\$ 30,613.51	\$ 30,613.51
9102 - CCES Yearbook	\$ 6,186.60	\$ 6,186.60
9103 - Thespians	\$ 1,123.11	\$ 1,123.11
9104 - Student Council	\$ 1,288.24	\$ 1,288.24
9105 - Exploring Free Enterprise (HAL Store)	\$ 367.44	\$ 367.44
9106 - CCS Flower Fund	\$ 285.01	\$ 285.01
9107 - Technology	\$ 21,440.36	\$ 21,440.36
9108 - Electric Car Project	\$ 1,825.39	\$ 1,825.39
9200 - FBLA	\$ 12,964.77	\$ 12,964.77
9205 - FCCLA	\$ 14,667.72	\$ 14,667.72

Description	09 - Activity	Total
9207 - Pro-Start	\$ 778.89	\$ 778.89
9210 - FFA	\$ 44,105.73	\$ 44,105.73
9211 - FFA-Sponsor	\$ (147.76)	\$ (147.76)
9212 - FFA-Farm Account	\$ 4,385.38	\$ 4,385.38
9213 - FFA-Memorial	\$ 2,649.59	\$ 2,649.59
9215 - I.A. Resale	\$ 2,845.76	\$ 2,845.76
9216 - Skills USA	\$ 117.69	\$ 117.69
9217 - Diversified Occupations	\$ 78.02	\$ 78.02
9300 - Show Choir	\$ 3,990.54	\$ 3,990.54
9301 - Show Choir Outfits	\$ 1,009.68	\$ 1,009.68
9302 - Musical	\$ 3,109.24	\$ 3,109.24
9303 - CCES Music Resale	\$ 320.84	\$ 320.84
9304 - Band Instrument Rental	\$ 400.00	\$ 400.00
9305 - Band Resale	\$ 9,261.28	\$ 9,261.28
9306 - SPVA Music	\$ 798.76	\$ 798.76
9308 - Drama	\$ 1,850.98	\$ 1,850.98
9309 - Fine Arts	\$ 4,525.43	\$ 4,525.43
9310 - Young Americans	\$ 270.00	\$ 270.00
9400 - Alumni Clearing	\$ 2,089.91	\$ 2,089.91
9401 - Table Fund	\$ 255.00	\$ 255.00
9402 - CCES Activity Fund	\$ 1,181.57	\$ 1,181.57
9404 - KG Snacks	\$ 36.06	\$ 36.06
9405 - Art Resale	\$ 1,294.13	\$ 1,294.13
9406 - Assignment Books	\$ 2,123.50	\$ 2,123.50
9407 - Lock Resale	\$ 1,149.35	\$ 1,149.35
9408 - Library Book Sales	\$ 296.74	\$ 296.74
9409 - Defib Training/Flu Vac Fund	\$ 845.89	\$ 845.89
9410 - Milk Vending	\$ 5,941.28	\$ 5,941.28
9411 - Adult Ed	\$ 706.48	\$ 706.48
9412 - Special Projects	\$ 12,926.04	\$ 12,926.04
9413 - Kiewit (Emergency Clothing/Food Assistance)	\$ 12.17	\$ 12.17
9414 - Staff/Student Appreciation	\$ 78.28	\$ 78.28
9415 - Monthly Interest	\$ 1,869.86	\$ 1,869.86
9505 - Class of 2016	\$ 2,624.52	\$ 2,624.52
9506 - Class of 2017	\$ 7,850.44	\$ 7,850.44
9507 - Class of 2018	\$ 4,501.22	\$ 4,501.22
9508 - Class of 2019	\$ 1,075.00	\$ 1,075.00
9801 - Doug Kunnemann Memorial	\$ 592.40	\$ 592.40
9802 - Gladys B & Les Smith Scholarship	\$ 1,300.00	\$ 1,300.00
9803 - Breakfast	\$ 1,541.14	\$ 1,541.14
9804 - Alta Heir Scholarship	\$ 2,000.00	\$ 2,000.00
9999 - Clearing	\$ 9,781.12	\$ 9,781.12
<b>Total Other Financing Sources (Uses)</b>	<b>\$ 281,372.74</b>	<b>\$ 281,372.74</b>
<b>Excess (deficiency) of revenues and other financing sources over expenditures and other financing uses</b>	<b>\$ 172,243.40</b>	<b>\$ 172,243.40</b>
Fund Balance, Beginning of year	\$ -	\$ -
<b>Fund Balance, End of year</b>	<b>\$ 172,243.40</b>	<b>\$ 172,243.40</b>

Bank: Adams Bank &amp; Trust Activity Fund; Bank Account: 2435737; Begin Check Number: 7270; End Check Number: 7287; Check Status: &lt;All&gt;

Bank	Account Number
Adams Bank & Trust Activity Fund	2435737

Paid Date	Check Number	Type	Vendor Name	Amount	Check Status
6/6/2016	7270	Accounts Payable	Callam Sports Photo	\$ 168.00	Paid
6/6/2016	7271	Accounts Payable	Hauff Sporting Goods	\$ 1,083.78	Paid
6/6/2016	7272	Accounts Payable	Hayes, Randy L	\$ 112.10	Paid
6/6/2016	7273	Accounts Payable	NSAA	\$ 297.00	Paid
6/6/2016	7274	Accounts Payable	Owens True Value	\$ 30.97	Paid
6/6/2016	7275	Accounts Payable	Ramada Inn-Kearney	\$ 166.00	Paid
6/6/2016	7276	Accounts Payable	Superfoods	\$ 148.75	Paid
6/6/2016	7277	Accounts Payable	Team Graphics	\$ 278.25	Paid
6/6/2016	7278	Accounts Payable	Westfahl, Wanda M	\$ 6.00	Paid
6/14/2016	7279	Accounts Payable	Added Touch	\$ 336.40	Paid
6/14/2016	7280	Accounts Payable	Association for Career & Technical Educ	\$ 142.00	Paid
6/14/2016	7281	Accounts Payable	Casey Francis	\$ 1,500.00	Paid
6/14/2016	7282	Accounts Payable	Hills Family Foods	\$ 67.33	Paid
6/14/2016	7283	Accounts Payable	Imperial Republican	\$ 110.00	Paid
6/14/2016	7284	Accounts Payable	Inter-State Publishing Co	\$ 262.95	Paid
6/14/2016	7285	Accounts Payable	NSAA	\$ 930.00	Paid
6/14/2016	7286	Accounts Payable	Pizza Hut	\$ 273.59	Paid
6/14/2016	7287	Accounts Payable	Universal Cheerleaders Association	\$ 878.00	Paid
<b>Subtotal</b>				<b>\$ 6,791.12</b>	
<b>Total</b>				<b>\$ 6,791.12</b>	

Invoice No.	Submit Date	PO No.	Payment Vendor	Comment	Invoice Amount
1505	7/8/2016		20/20 Technologies LLC	July Managed Services Agreement	\$ 1,500.00
GatorLease	7/8/2016		21st Century Equipment	gator Lease July	\$ 250.00
P12491	7/8/2016	6780	21st Century Equipment	grounds equipment	\$ 66.85
061216	6/30/2016		A T & T	LD 5/13-6/10	\$ 168.64
385634/386113	6/30/2016		Adams Lumber Co	concrete mix,bit holder, tape, joint cement, texture pneumatic gun, safety grab bar, sheet rock,	\$ 173.30
16033	6/30/2016		Advanced Education, Inc.	2016-17 External Review	\$ 750.00
265382A-2	6/30/2016		Attainment Company, Inc	shipping missed on PO 6806 (math/geography books)	\$ 14.90
27795	6/30/2016		Baker and Associates	feasibility	\$ 26,392.50
6171141	6/30/2016	6828	Blick Art Materials	art materials	\$ 1,412.21
71055915	7/8/2016		Bomgaars	supplies for maintenance of property	\$ 69.06
15800	7/8/2016		Brico Pest Control	regular service	\$ 44.00
CI10516179	7/8/2016		Capstone Press	Library books	\$ 2,649.40
112970/113028/11312E	7/8/2016		Carquest Auto Parts	air filters,couplers,worklight cord	\$ 210.45
723023	6/30/2016	6801	Carson Dellosa Publishing Co	Interactive Notebook, Flash cards, scalloped borders, place value chart, number line set	\$ 62.89
722758	6/30/2016	6792	Carson Dellosa Publishing Co	black borders, ez letters, stickers, recognition awards, notepad, chart seals	\$ 32.13
722433	6/30/2016	6814	Carson Dellosa Publishing Co	Number line bulletin board	\$ 18.94
722434	6/30/2016	6796	Carson Dellosa Publishing Co	jungle safari BB Set, name tags, decorations, bookmarks, stickers,incentive chart, boarders, ez letters	\$ 80.54
753174	6/30/2016	6869	CDI Computers	Chromebooks, Google Management License	\$ 57,000.00
2016Census	7/1/2016		Chandler, Julie	Prep for 2016 Census Report	\$ 1,200.00
990069234	7/1/2016		Chase County Hospital	xrays, medical treatment for employee	\$ 234.00
5/01-6/01	7/1/2016		Chase County Hospital	PT for 4/05-5/18	\$ 597.50
07152016	7/6/2016		City Of Imperial	5/15-6/17	\$ 11,639.23
308102473362	7/7/2016	6812	Classroom Direct	Classroom supplies	\$ 131.31
205745	7/8/2016	6878	Cornhusker Cleaning	cleaner for busses	\$ 43.06
3300388	7/8/2016	6874	Cornhusker Internationl Trucks, Inc.	cylinder kit for lift, parts for lift, oil for lift, bumper, lift arms	\$ 240.47
2493-47/2887-42	7/8/2016		Culligan	32-30 lb bags of salt	\$ 568.20
010-57727	7/8/2016	6887	Cummins Central Power	rear valve cover, oil rerun line, return fuel lines	\$ 38.59
49715	6/30/2016	6820	Dahlstrom and Company	Job Hunting Handbook	\$ 170.50
49715-2	6/30/2016		Dahlstrom and Company	PO 6820 shipping/handling	\$ 16.50
5900254	7/1/2016	6760	Demco, Inc.	bookmarks,plush characters, stationary step stool, prelaminated dots	\$ 305.47
S126956	7/1/2016		Eakes Office Solutions	copies	\$ 11,596.93
003454	7/1/2016		ESU #16	2016-17 SNDEN Service Contract	\$ 23,000.00
7889/7721	7/1/2016	6673	Everything Medical	Bandages, gauze pads, cold packs, probe covers, skin dressing	\$ 117.08
2022879128	7/5/2016		Express Toll	Toll Transaction 5/13/16	\$ 22.80
6464	7/1/2016		Falcon Laboratories	janitorial cleaning supplies	\$ 309.57
FCCLAADTrng	6/27/2016		FCCLA	FCCLA Adviser Training Registration	\$ 20.00
568211	7/8/2016	6851	Frenchman Valley Co-op	Balance Van tires	\$ 40.00
06202016	7/8/2016		Frenchman Valley Co-op	5/20-6/20 bulk Fuel	\$ 1,217.13
9173858/9175524	7/5/2016		Gopher Performance	Tchoukball Pack,Bone Chart, Muscle chart, Rule of the gym, Foam dodge balls,Spike ball game set	\$ 1,460.74
PEV061416	6/29/2016		Hanna, Cathryn A	reimbursement for hotel room for No Excuses Conference.	\$ 304.86
06022016	6/14/2016		Hershberger Piano & Organ	repairs on instruments	\$ 548.50
36142/36141/36134361	6/29/2016		Hershberger Piano & Organ	repairs on instruments 5/26/16	\$ 490.00
1598	7/5/2016		Holiday Farms	mowing/spraying football fields.	\$ 4,600.00
53787	7/5/2016		Holiday Inn Of Kearney	Hotel Room for Nurse/Conference	\$ 177.90
7/10/2016	6/30/2016		Hometown Leasing	copier lease	\$ 962.11
12-80663	7/8/2016	6894	Inland	transmission output shaft seal	\$ 26.45
12-80617	7/8/2016	6876	Inland	park brake	\$ 112.11
S287958	7/5/2016	6821	IXL Learning	1 year IXL Site License	\$ 3,063.00

Invoice No.	Submit Date	PO No.	Payment Vendor	Comment	Invoice Amount
18784927/18554300	6/29/2016		Jostens Inc	Diplomas (35)	\$ 172.47
3064890616	7/5/2016	6757	Lakeshore Learning	Calendar Math Activity program	\$ 114.43
3064900616	7/5/2016	6788	Lakeshore Learning	The allowance game, fraction tiles, Magnetic map of US. Fraction equivalency puzzles, time equalency pu	\$ 104.94
3064900616-2	7/5/2016		Lakeshore Learning	shipping/handling not on PO 6788	\$ 15.74
3064920616	7/5/2016	6790	Lakeshore Learning	student timer, speak-listen recording microphones, intermeiate rdg trackers	\$ 157.50
3064940616	7/5/2016	6799	Lakeshore Learning	Magnetic Math Manipulatives Library, Student Gear Clocks	\$ 413.90
3065000616	7/5/2016	6813	Lakeshore Learning	Self Inking Teacher Stamps	\$ 24.99
306502616	7/5/2016	6826	Lakeshore Learning	classroom supplies	\$ 242.56
68548141/68548438/68	6/27/2016		LaQuinta Inn & Suites-Kearney	Hotel rooms/NCE conference June 5-9,2016	\$ 958.00
92377207001	7/6/2016	6841	McGraw-Hill	Your Turn Practice Book grade 3	\$ 352.80
92377207001-2	7/6/2016		McGraw-Hill	shipping/handling missed on PO 6841	\$ 55.56
92377207002	7/6/2016	6831	McGraw-Hill	xtbooks	\$ 1,173.90
92377207002-2	7/6/2016		McGraw-Hill	Shipping/Handling missed on PO6831	\$ 135.58
92398093001	7/6/2016	6802	McGraw-Hill	text books	\$ 2,077.80
92398093001-2	7/6/2016		McGraw-Hill	shipping/handling missing on PO6802	\$ 134.32
BOND	7/6/2016		McNair Agency Inc	Treasurer Bond 1- year	\$ 100.00
9494/949306519	6/29/2016		Menards	Landscaping materials, building grounds maintenance materials	\$ 660.35
M0031371	7/6/2016	6848	Modern School Supplies, Inc	Paper	\$ 84.14
M0031371-2	7/6/2016		Modern School Supplies, Inc	shipping/handling missed on PO 6848	\$ 21.94
MS493607	6/29/2016		MyService	repair broken glass on MAC	\$ 179.00
MS497952	6/27/2016		MyService	MAC laptop repair/cracked screen & loose hinges	\$ 299.00
975978	7/6/2016	6823	NASCO	Classic Heart (Phys Ed)	\$ 69.53
MDS-60998	7/6/2016	6774	National FFA Organization	FFA activities wall chart	\$ 28.00
44919	7/6/2016		NE Council School Administrators	2016 Student Handbook wrkshop	\$ 500.00
2016NCE	6/29/2016		NE Council School Administrators	2016 NCE Conference-registration/fees	\$ 948.00
0155883	7/6/2016	6747	Nebraska Central Equipment	parts buses	\$ 240.22
0155996	7/8/2016	6890	Nebraska Central Equipment	block heater , bumper cover, cover assy	\$ 220.65
678253196-01	7/6/2016	6791	Oriental Trading Company	library supplies	\$ 129.93
678253249-01	7/6/2016	6794	Oriental Trading Company	classroom supplies	\$ 45.23
678253249-01-2	7/6/2016		Oriental Trading Company	shipping not included on PO 6794	\$ 9.99
4/26-27	7/8/2016		Owens True Value	bus barn supplies/maintenance	\$ 2,154.57
5/26-6/25	7/8/2016		Owens True Value	past due amount from 4/25 bill	\$ 323.42
1679722/1679722-01/0	7/7/2016	6609	Perma Bound	Library books	\$ 408.26
16932	7/7/2016	6618	Prairie States Communications	Street Trek bus GPS software, reprogram vehicle radios, GPS Antenna's, Intall antennas on buses.	\$ 6,160.85
16932-2	7/7/2016		Prairie States Communications	WHIP for UHF Gain Antenna for Bus #3)	\$ 16.00
16380	7/7/2016		Prairie States Communications	Used VHF M1225 mobile radio-not compatible with school system	\$ (150.00)
204500455523	7/7/2016		Premier Agendas	Calendars/agendas	\$ 1,216.00
5544907	7/7/2016	6789	Really Good Stuff	Classroom supplies	\$ 666.38
5544342	7/7/2016	6815	Really Good Stuff	classroom supplies	\$ 205.19
5544346	7/7/2016	6825	Really Good Stuff	classroom supplies	\$ 69.21
5544320	7/7/2016	6800	Really Good Stuff	Classroom supplies	\$ 84.79
5544918	7/7/2016	6803	Really Good Stuff	classroom supplies	\$ 492.67
5546255	7/7/2016	6798	Really Good Stuff	classroom supplies	\$ 374.28
5544333	7/8/2016	6811	Really Good Stuff	classroom supplies	\$ 148.12
5544338	7/8/2016	6808	Really Good Stuff	classroom supplies	\$ 435.42
201663677	7/7/2016		Recognition Unlimited	brass/rosewood arch clocks for retirement teachers	\$ 177.90
201663775	7/7/2016		Recognition Unlimited	brass/gold border plate for clocks	\$ 5.95
4246236	7/7/2016	6725	Renaissance Learning	AR dog tags	\$ 2,769.00

Invoice No.	Submit Date	PO No.	Payment Vendor	Comment	Invoice Amount
M8567321	7/7/2016	6607	Scholastic Magazine	Jr Scholastic magazine year subscription	\$ 125.25
M8567321-2	7/7/2016		Scholastic Magazine	shipping and handling missed on PO6607	\$ 125.25
M5864901	7/7/2016	6839	Scholastic News	Scholastic news , Grade 2	\$ 315.00
M5864901-2	7/7/2016		Scholastic News	shipping/handling missed on PO 6839	\$ 31.50
308102474958	7/7/2016	6758	School Specialty Supply Inc	Sped Classroom supplies	\$ 334.41
308102471250	7/7/2016		School Specialty Supply Inc	Classroom supplies	\$ 1,137.37
208116371096	7/8/2016	6772	School Specialty Supply Inc	classroom supplies	\$ 444.36
208116370550	7/8/2016	6797	School Specialty Supply Inc	classroom supplies	\$ 299.30
208116370688	7/8/2016	6830	School Specialty Supply Inc	classroom supplies	\$ 361.14
208116385162	7/8/2016	6810	School Specialty Supply Inc	classroom supplies	\$ 250.99
PEV52716	7/8/2016		Shriver, Fred	Home depot -scraper blades	\$ 17.06
PEV42116	7/8/2016		Silvester, Kent L	gas for van to Beloit KS power drive	\$ 72.19
207408049189/201270:6/17/2016			SourceGas CCCF	04/07-05/05	\$ 2,325.79
207408049786	6/29/2016		SourceGas CCCF	5/06-6/06	\$ 1,170.53
15346/15670	7/8/2016		Southwest Nebraska Solid Waste Agency	disposal of commercial waste	\$ 31.20
N Star 16-17 #20	6/27/2016		SparqData Solutions	April 1, 2016 - March 31, 2017 Annual North Star Neg. Software	\$ 1,600.00
16582	7/8/2016	6740	Summit Products	AR dog tags	\$ 209.00
16582-2	7/8/2016		Summit Products	shipping/handling missed on PO 6740	\$ 13.25
365063171/369664727	7/8/2016		SupplyWorks	upright vacuum,fan exhaust, toliet, bearing clip	\$ 1,197.03
53185	7/8/2016	6733	Supreme School Supply Co.	Teacher Daily Reference	\$ 147.50
53185-1	7/8/2016		Supreme School Supply Co.	shipping/handling missed on PO 6733	\$ 20.65
P462431900014	7/8/2016	6784	Teacher Direct	textbooks	\$ 59.12
205327	7/8/2016	6633	The Library Store	self adhesive book pockets	\$ 22.75
1745738/1749051/1756	7/8/2016		Thompson Company-Maint	janitorial supplies, dispoables	\$ 832.87
120738	7/8/2016		UNISAN	cleaning supplies	\$ 229.40
06-27-2016	7/8/2016		US Bank	See detail report	\$ 13,999.55
9767386566/97663011:7/8/2016			Verizon Wireless	May 2-Jun 01/May 21- June 20	\$ 240.98
PEV63016	7/8/2016		Westfahl, Wanda M	bus license	\$ 7.50
74804	7/8/2016	6804	Wieser Educational	text binders, text books	\$ 227.95
74804-2	7/8/2016		Wieser Educational	shipping handling left off PO 6804	\$ 22.80
1003018	7/8/2016	6748	William V. Macgill & Co	Nurse supplies	\$ 357.39
10063814	7/8/2016	6843	Zaner-Bloser Educational Publishers	Handwriting Grade 3 Books	\$ 479.60
10063814-2	7/8/2016		Zaner-Bloser Educational Publishers	shipping/handling left off of PO6843	\$ 43.16
10063864	7/8/2016	6840	Zaner-Bloser Educational Publishers	handwriting books 2nd grade	\$ 728.39
1006364-2	7/8/2016		Zaner-Bloser Educational Publishers	shipping/handling missed on PO 6840	\$ 65.56
10063847	7/8/2016	6834	Zaner-Bloser Educational Publishers	handwriting books grade 1	\$ 719.40
10063847-2	7/8/2016		Zaner-Bloser Educational Publishers	shipping/handling missing on PO 6834	\$ 64.75
				Subtotal July Bills	\$ 207,708.24
				Payroll July	\$ 452,284.36
				Total July General Expenditures	\$ 659,992.60

# Activities Director's Report

## **Athlete's continue to be active with Summer Camps!!!**

The Nebraska School Activities Association will hold the annual coaching clinic in Lincoln on July 26th, 27th, and 28th. We have 9 coaches registered to attend the clinic.

The Longhorn and Shorthorn gym floors were refinished last week. Quotes for each gym are as follows:

Prices stayed the same as last year.

Longhorn Gym: \$2,890.00 (2 coats of Showtime Urethane Oil Base Finish)

Shorthorn Gym: \$1,850.00

The Wellington Gym will be refinished next week.

Wellington Gym: \$2,250.00 (2 coats of Hydra Kote Waterborne Urethane Finish)

We have looked at both Pepsi and Coke Proposals and Pepsi is offering a better deal.

### **Pepsi Proposal Elements**

**5 Year Contract**

**\$5,000 for new gym signage**

**\$3,000 per year**

**\$400 a year for 5 Years for Gatorade Sideline kit**

### **Specialty Installation LLC out of Rapid City, SD**

Completed installation of 12 replacement motors for the basketball backstops in the Longhorn and Shorthorn Gyms. Installed 4 safety straps on the main court backstops in both gyms and replaced 1 defective strap on the main gym practice court. Randy also inspected and looked over the bleachers again while he was here and sent an estimate on replacement edge pads for the glass backboards.

**NSAA-** Released Classifications today. We have moved from Class D in Cross Country to Class C for the 2016 season.



# Chase County

**July, 2016**

Sunday	Monday	Tuesday	Wednesday	Thursday	Friday	Saturday
					1	2
3	4	5	6	7	8	9
10	11	12 6:00pm Monthly Meeting @ Board Room	13	14	15	16
17	18	19	20	21	22	23
24	25	26 NCA Coaches Clinic @ Lincoln	27 NCA Coaches Clinic @ Lincoln	28 NCA Coaches Clinic @ Lincoln	29	30
31						

## August, 2016

Sunday	Monday	Tuesday	Wednesday	Thursday	Friday	Saturday
	1	2	3	4	5	6
7	8 Start of Fall Practice for Football and Softball	9 <b>6:00pm</b> Monthly Meeting @ Board Room	10	11 <b>8:00am</b> Teacher In-Service	12 <b>8:00am</b> Teacher In-Service	13
14	15 Chase County Fair Start of Fall Practice for Cross Country and Volleyball	16 Chase County Fair	17 <b>7:00pm</b> Chase County Fair @ Longhorn Gym	18 Chase County Fair <b>1:00pm</b> 9th St. Singers	19 Chase County Fair	20 Chase County Fair <b>10:00am</b> Chase County Band Performs during the Parade
21 Chase County Fair	22 <b>6:00pm</b> Fall Booster Club Kick Off @ Chase County Schools	23 <b>3:00am-6:00pm</b> K-6 <b>3:00pm</b> Softball-Varsity <b>Southern Valley vs. Multiple Schools</b>	24 1st Day of School <b>6:00pm</b> Fall SPVA Meeting @ Paxton	25 <b>4:30pm</b> Softball-Varsity <b>Southern Valley vs. Multiple Schools</b>	26 <b>6:30pm</b> Football-B/Varsity Cozad	27
28	29	30 <b>4:00pm</b> Softball-Varsity <b>Away vs. Holyoke</b>	31			

From: **Ed Johnson** [ejohnson@nasbonline.org](mailto:ejohnson@nasbonline.org)  
Subject: Experience Modifier  
Date: June 20, 2016 at 5:46 PM  
To: Joey Lefdal [jlefdal@ccschools.cc](mailto:jlefdal@ccschools.cc)



Great news! Your experience modifier for the 2016-2017 school year will be .69 as compared to .95 for the current school year. A 26 percent decrease in premium is commendable. Keep up the good work.

Hope all is well. I will see you in mid to late August.

Take care,

Ed Johnson



Mail Processing Center  
 Federal Aviation Administration  
 Southwest Regional Office  
 Obstruction Evaluation Group  
 10101 Hillwood Parkway  
 Fort Worth, TX 76177

Aeronautical Study No.  
 2016-ACE-2267-OE

Issued Date: 06/17/2016

Joey Lefdal  
 Chase County Schools  
 P.O. Box 637  
 Imperial, NE 69033

**\*\* DETERMINATION OF NO HAZARD TO AIR NAVIGATION \*\***

The Federal Aviation Administration has conducted an aeronautical study under the provisions of 49 U.S.C., Section 44718 and if applicable Title 14 of the Code of Federal Regulations, part 77, concerning:

Structure: Building Chase County Schools  
 Location: Imperial, NE  
 Latitude: 40-31-15.39N NAD 83  
 Longitude: 101-38-02.66W  
 Heights: 3285 feet site elevation (SE)  
 33 feet above ground level (AGL)  
 3318 feet above mean sea level (AMSL)

This aeronautical study revealed that the structure does not exceed obstruction standards and would not be a hazard to air navigation provided the following condition(s), if any, is(are) met:

~~It is required that FAA Form 7460-2, Notice of Actual Construction or Alteration, be e-filed any time the project is abandoned or:~~

- ~~\_\_\_\_\_~~ At least 10 days prior to start of construction (7460-2, Part 1)
- X   Within 5 days after the construction reaches its greatest height (7460-2, Part 2)

Based on this evaluation, marking and lighting are not necessary for aviation safety. However, if marking/lighting are accomplished on a voluntary basis, we recommend it be installed and maintained in accordance with FAA Advisory circular 70/7460-1 L.

This determination expires on 12/17/2017 unless:

- (a) the construction is started (not necessarily completed) and FAA Form 7460-2, Notice of Actual Construction or Alteration, is received by this office.
- (b) extended, revised, or terminated by the issuing office.
- (c) the construction is subject to the licensing authority of the Federal Communications Commission (FCC) and an application for a construction permit has been filed, as required by the FCC, within 6 months of the date of this determination. In such case, the determination expires on the date prescribed by the FCC for completion of construction, or the date the FCC denies the application.

# Nebraska Agriculture, Food and Natural Resources Programs of Study & Course Standards Outline

Students taking linked courses at the introductory, intermediate and capstone levels are considered a completer of a *Pathway-Level Program of Study*. Students may also complete a *Cluster-Level Program of Study* by taking all three courses indicated with © and one additional course indicated by a ⊕. Standards, benchmarks and sample performance indicators are available for each course at [www.neaged.org](http://www.neaged.org).

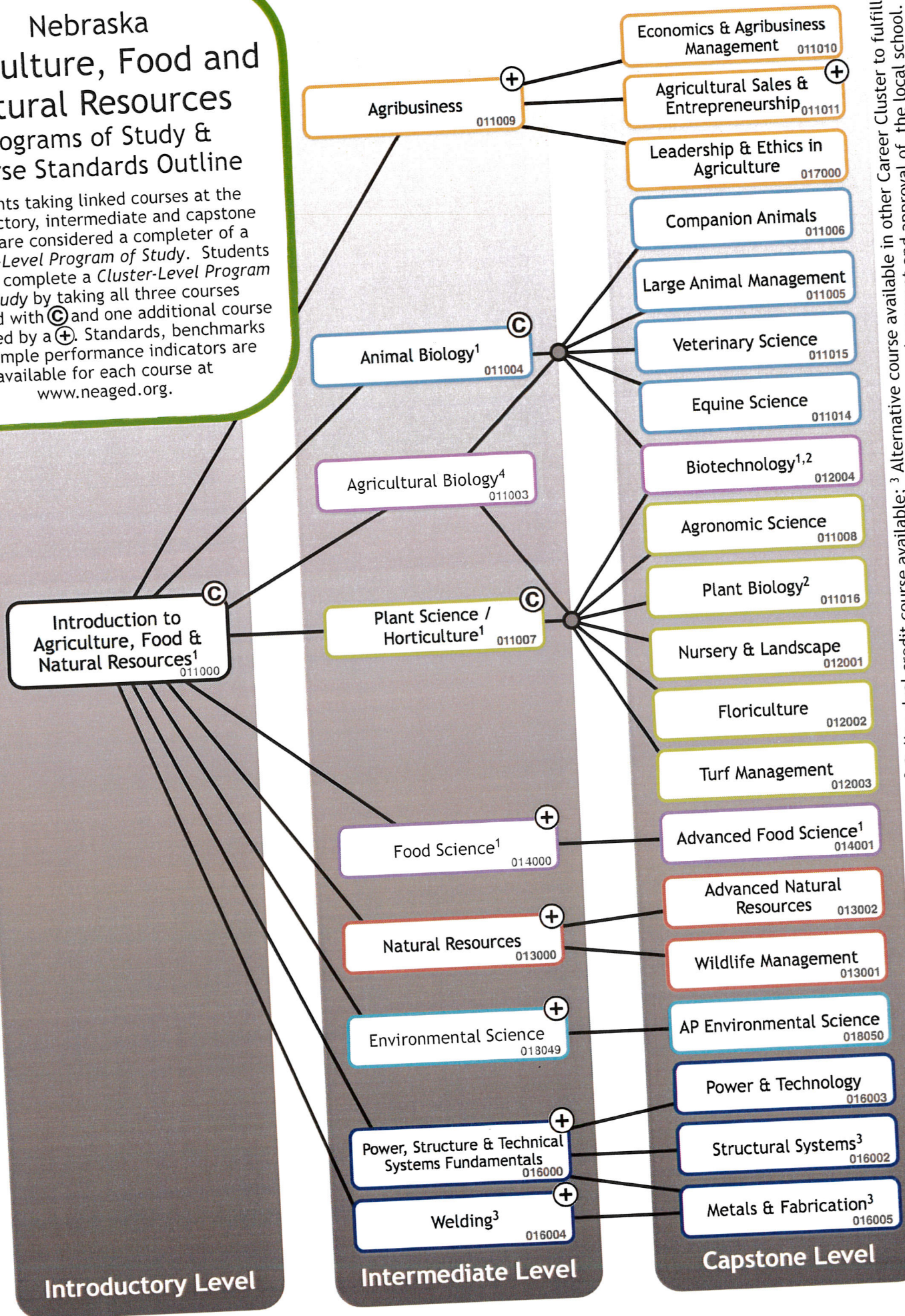

1 Indicates that an equivalent CASE or FNS course is available; 2 Online dual credit course available; 3 Alternative course available in other Career Cluster to fulfill POS; that may substitute in place of high school biology with proper teacher endorsement and approval of the local school.



## 2016-2017 Nebraska Career Education Programs of Study

Skilled and Technical Sciences Career Field



Architecture and Construction Cluster

Full Year Course 1

Cluster Level Program of Study (POS)			
Sequence of CTE Courses	Introduction Course	Intermediate Course	Capstone Course
A & C Basic	100100 Introduction to the Built Environment	100140 Computer Aided Drafting	100110 Principles of Construction Technology (STS) - OR- 016002 Structural Systems (AG)

Full Year Course 1

Pathway Level Program of Study (POS)			
Sequence of CTE Courses	Introduction Course	Intermediate Course	Capstone Course
DPC - Drafting	100100 Introduction to the Built Environment	100140 Computer Aided Drafting -OR- 103192 Engineering Concepts	100141 Applications in Design and Pre-Construction
DPC - Engineering Arch Drafting	103191 Introduction to Engineering	103192 Engineering Concepts	100141 Applications in Design and Pre-Construction
DPC - Basic Drafting	100100 Introduction to the Built Environment	100130 Introduction to Architecture & Construction	100141 Applications in Design and Pre-Construction
DPC - Fundamental Drafting	100140 Computer Aided Drafting	100130 Introduction to Architecture & Construction	100141 Applications in Design and Pre-Construction
DPC - FCS Drafting	090109 Housing and Interior Design	100130 Introduction to Architecture & Construction	100141 Applications in Design and Pre-Construction
DPC - Arch Drafting	103191 Introduction to Engineering	100130 Introduction to Architecture & Construction	100141 Applications in Design and Pre-Construction
DPC - PLTW Drafting	100161 PLTW Introduction to Engineering Design <span style="border: 1px solid black; padding: 2px;">1</span>	100130 Introduction to Architecture & Construction	100141 Applications in Design and Pre-Construction
DPC - PLTW Arch Drafting	100100 Introduction to the Built Environment -OR- 100140 Computer Aided Drafting	100130 Introduction to Architecture & Construction	100162 PLTW Civil Engineering and Architecture <span style="border: 1px solid black; padding: 2px;">1</span>

<b>CONST - Basic Construction</b>	100100 Introduction to the Built Environment -OR- 100140 Computer Aided Drafting	100110 Principles of Construction Technology (STS) - OR- 016002 Structural Systems (AG)	100120 Advanced Construction Technology
<b>CONST - PLTW Basic Construction</b>	100161 PLTW Introduction to Engineering Design 	100110 Principles of Construction Technology (STS) - OR- 016002 Structural Systems (AG)	100120 Advanced Construction Technology
<b>CONST - Electricity Based</b>	100405 Electricity	100110 Principles of Construction Technology (STS) - OR- 016002 Structural Systems (AG)	100120 Advanced Construction Technology
<b>CONST - Construction Technology</b>	100100 Introduction to the Built Environment	100405 Electricity	100120 Advanced Construction Technology
<b>CONST - PLTW Construction Technology</b>	100161 PLTW Introduction to Engineering Design 	100405 Electricity	100120 Advanced Construction Technology

**Tony Glenn**  
 Skilled and Technical Sciences  
 Career Field Specialist

402.471.4819  
 tony.glenn@nebraska.gov  
 www.education.ne.gov/sts



**2016-2017 Nebraska Career Education Programs of Study**

Human Sciences and Education Career Field

Human Services Cluster

**Cluster Level Program of Study (POS)**

Sequence of CTE Courses	Introduction Course	Intermediate Course	Capstone Course
Human Sciences	090101 Introduction to Human Sciences/FCS	090107 Human Food, Nutrition and Wellness	350002 Human Growth and Development -OR- 090116 Relationships
Human Food, Development, and Behavior	090107 Human Food, Nutrition and Wellness	350002 Human Growth and Development -OR- 090119 Child Development	090116 Relationships

**Pathway Level Program of Study (POS)**

Sequence of CTE Courses	Introduction Course	Intermediate Course	Capstone Course
Consumer Services	090101 Introduction to Human Sciences/FCS	090104 Life and Career Readiness	033000 Personal Finance
Counseling & Mental Health Services	350002 Human Growth and Development	090116 Relationships	151200 Psychology -OR- 151210 AP Psychology
Early Childhood Development & Services	090119 Child Development	090117 Parenting Decisions -OR- 350002 Human Growth and Development	090116 Relationships -OR- 151200 Psychology
Textile Science	090103 Textiles, Construction & Design	090206 Fashion Design and Marketing	320600 Fundamentals of Entrepreneurship
Human Food, Nutrition, and Wellness	090101 Introduction to Human Sciences/FCS	090107 Human Food, Nutrition and Wellness	090108 Advanced Human Food, Nutrition & Wellness
Food and Nutrition Science	018080 FNS Food Production, Nutrition, and Health	018082 FNS Nutrition Science	018081 FNS Food Science
Housing	090101 Introduction to Human Sciences/FCS	090109 Housing and Interior Design	320600 Fundamentals of Entrepreneurship



## 2016-2017 Nebraska Career Education Programs of Study

Agriculture, Food, and Natural Resources Career Field

Agriculture, Food, and Natural Resources Cluster

### Cluster Level Program of Study (POS)







Sequence of CTE Courses	Introduction Course	Intermediate Course	Capstone Course
<b>Agriculture, Food, and Natural Resources: Life Science &amp; Business</b>	011000 Intro to Agriculture, Food and Natural Resources -OR- 018060 CASE Introduction to AFNR	011004 Animal Biology -AND- 011007 Plant Science/Horticulture -AND- 011009 Agribusiness	
<b>CASE: Curriculum for Ag Science Ed Certified</b>	018060 CASE Introduction to AFNR	018061 CASE Plant Science -OR- 018062 CASE Animal Science	018063 CASE Animal And Plant Biotechnology
<b>Agriculture, Food, and Natural Resources: Life Science &amp; Food</b>	011000 Intro to Agriculture, Food and Natural Resources -OR- 018060 CASE Introduction to AFNR	011004 Animal Biology -AND- 011007 Plant Science/Horticulture -AND- 014000 Food Science	
<b>Agriculture, Food, and Natural Resources: Life Science &amp; Natural Resources</b>	011000 Intro to Agriculture, Food and Natural Resources -OR- 018060 CASE Introduction to AFNR	011004 Animal Biology -AND- 011007 Plant Science/Horticulture -AND- 013000 Natural Resources	
<b>Agriculture, Food, and Natural Resources: Life Science &amp; Environment</b>	011000 Intro to Agriculture, Food and Natural Resources -OR- 018060 CASE Introduction to AFNR	011004 Animal Biology -AND- 011007 Plant Science/Horticulture -AND- 018049 Environmental Science	

<b>Agriculture, Food, and Natural Resources: Life Science &amp; Power</b>	011000 Intro to Agriculture, Food and Natural Resources -OR- 018060 CASE Introduction to AFNR	011004 Animal Biology -AND- 011007 Plant Science/Horticulture -AND- 016000 Power, Structure, and Technical Systems Fundamentals	
<b>Agriculture, Food, and Natural Resources: Life Science &amp; Metals</b>	011000 Intro to Agriculture, Food and Natural Resources -OR- 018060 CASE Introduction to AFNR	011004 Animal Biology -AND- 011007 Plant Science/Horticulture -AND- 016004 Welding (AG)	
<b>Agriculture, Food, and Natural Resources: Life Science &amp; Sales</b>	011000 Intro to Agriculture, Food and Natural Resources -OR- 018060 CASE Introduction to AFNR	011004 Animal Biology -AND- 011007 Plant Science/Horticulture	011011 Agricultural Sales and Entrepreneurship

**Pathway Level Program of Study (POS)**

Sequence of CTE Courses	Introduction Course	Intermediate Course	Capstone Course
<b>Agribusiness Systems: Economics and Management</b>	011000 Intro to Agriculture, Food and Natural Resources -OR- 018060 CASE Introduction to AFNR	011009 Agribusiness	011010 Economics & Agribusiness Management
<b>Agribusiness Systems: Agricultural Sales &amp; Entrepreneurship</b>	011000 Intro to Agriculture, Food and Natural Resources -OR- 018060 CASE Introduction to AFNR	011009 Agribusiness	011011 Agricultural Sales and Entrepreneurship
<b>Agribusiness Systems: Leadership</b>	011000 Intro to Agriculture, Food and Natural Resources -OR- 018060 CASE Introduction to AFNR	011009 Agribusiness	017000 Leadership and Ethics in Agriculture
<b>Animal Systems: Companion Animal</b>	011000 Intro to Agriculture, Food and Natural Resources -OR- 018060 CASE Introduction to AFNR	011004 Animal Biology -OR- 018062 CASE Animal Science -OR- 011003 Agricultural Biology	011006 Companion Animals

1  
YEAR

<b>Animal Systems: Large Animal</b>	011000 Intro to Agriculture, Food and Natural Resources -OR- 018060 CASE Introduction to AFNR	011004 Animal Biology -OR- 018062 CASE Animal Science -OR- 011003 Agricultural Biology 	011005 Large Animal Management
<b>Animal Systems: Veterinary</b>	011000 Intro to Agriculture, Food and Natural Resources -OR- 018060 CASE Introduction to AFNR	011004 Animal Biology -OR- 018062 CASE Animal Science -OR- 011003 Agricultural Biology 	011015 Veterinary Science
<b>Animal Systems: Equine</b>	011000 Intro to Agriculture, Food and Natural Resources -OR- 018060 CASE Introduction to AFNR	011004 Animal Biology -OR- 018062 CASE Animal Science -OR- 011003 Agricultural Biology 	011014 Equine Science
<b>Animal Systems: Biotechnology</b>	011000 Intro to Agriculture, Food and Natural Resources -OR- 018060 CASE Introduction to AFNR	011004 Animal Biology -OR- 018062 CASE Animal Science -OR- 011003 Agricultural Biology 	012004 Biotechnology -OR- 018063 CASE Animal And Plant Biotechnology
<b>Plant Systems: Biotech</b>	011000 Intro to Agriculture, Food and Natural Resources -OR- 018060 CASE Introduction to AFNR	011007 Plant Science/Horticulture -OR- 018061 CASE Plant Science -OR- 011003 Agricultural Biology 	012004 Biotechnology -OR- 018063 CASE Animal And Plant Biotechnology
<b>Plant Systems: Agronomy</b>	011000 Intro to Agriculture, Food and Natural Resources -OR- 018060 CASE Introduction to AFNR	011007 Plant Science/Horticulture -OR- 018061 CASE Plant Science -OR- 011003 Agricultural Biology 	011008 Agronomic Science
<b>Plant Systems: Plant Biology</b>	011000 Intro to Agriculture, Food and Natural Resources -OR- 018060 CASE Introduction to AFNR	011007 Plant Science/Horticulture -OR- 018061 CASE Plant Science -OR- 011003 Agricultural Biology 	011016 Plant Biology

<b>Plant Systems: Nursery and Landscape</b>	011000 Intro to Agriculture, Food and Natural Resources -OR- 018060 CASE Introduction to AFNR	011007 Plant Science/Horticulture -OR- 018061 CASE Plant Science -OR- 011003 Agricultural Biology <span style="border: 1px solid black; padding: 2px;">1 YEAR</span>	012001 Nursery and Landscape
<b>Plant Systems: Floriculture</b>	011000 Intro to Agriculture, Food and Natural Resources -OR- 018060 CASE Introduction to AFNR	011007 Plant Science/Horticulture -OR- 018061 CASE Plant Science -OR- 011003 Agricultural Biology <span style="border: 1px solid black; padding: 2px;">1 YEAR</span>	012002 Floriculture
<b>Plant Systems: Turf</b>	011000 Intro to Agriculture, Food and Natural Resources -OR- 018060 CASE Introduction to AFNR	011007 Plant Science/Horticulture -OR- 018061 CASE Plant Science -OR- 011003 Agricultural Biology <span style="border: 1px solid black; padding: 2px;">1 YEAR</span>	012003 Turf Management
<b>Food Systems: Food &amp; Nutritional Science</b>	090107 Human Food, Nutrition and Wellness -OR- 011000 Intro to Agriculture, Food and Natural Resources -OR- 018060 CASE Introduction to AFNR	014000 Food Science -OR- 018080 FNS Food Production, Nutrition, and Health	014001 Advanced Food Science -OR- 018081 FNS Food Science
<b>Natural Resources Systems: Advanced Management</b>	011000 Intro to Agriculture, Food and Natural Resources -OR- 018060 CASE Introduction to AFNR	013000 Natural Resources	013002 Advanced Natural Resources
<b>Natural Resources Systems: Wildlife Management</b>	011000 Intro to Agriculture, Food and Natural Resources -OR- 018060 CASE Introduction to AFNR	013000 Natural Resources	013001 Wildlife Management
<b>Environmental Service Systems: Environmental Science</b>	011000 Intro to Agriculture, Food and Natural Resources -OR- 018060 CASE Introduction to AFNR	018049 Environmental Science	018050 Advanced Placement Environmental Science

<b>Power, Structural, and Technical Systems: Power and Tech</b>	011000 Intro to Agriculture, Food and Natural Resources -OR- 018060 CASE Introduction to AFNR	016000 Power, Structure, and Technical Systems Fundamentals	016003 Power and Technology (AG)
<b>Power, Structural, and Technical Systems: Structure Systems</b>	011000 Intro to Agriculture, Food and Natural Resources -OR- 018060 CASE Introduction to AFNR	016000 Power, Structure, and Technical Systems Fundamentals	016002 Structural Systems (AG) -OR- 100110 Principles of Construction Technology (STS)
<b>Power, Structural, and Technical Systems: Metals &amp; Fab</b>	011000 Intro to Agriculture, Food and Natural Resources -OR- 018060 CASE Introduction to AFNR	016000 Power, Structure, and Technical Systems Fundamentals -OR- 016004 Welding (AG) -OR- 101930 Manufacturing Welding (STS)	016005 Metals and Fabrication -OR- 101940 Advanced Welding Fabrication and Manufacturing (STS)
<b>FNS: Food &amp; Nutrition Science Certified</b>	018080 FNS Food Production, Nutrition, and Health	018081 FNS Food Science -OR- 018082 FNS Nutrition Science	018083 FNS Food and Nutrition Research and Development

**Matt Kreifels**

Agriculture, Food, and Natural Resources  
Career Field Specialist

402.617.1419

[matt.kreifels@nebraska.gov](mailto:matt.kreifels@nebraska.gov)

[www.neaged.org](http://www.neaged.org)





**2016-2017 Nebraska Career Education Programs of Study**

Skilled and Technical Sciences Career Field

Manufacturing Cluster





**Cluster Level Program of Study (POS)**

Full Year Course 

Sequence of CTE Courses	Introduction Course	Intermediate Course	Capstone Course
<b>Man - Drafting</b>	100100 Introduction to the Built Environment	100140 Computer Aided Drafting	101920 Manufacturing - Woods
<b>Man - Basic</b>	100100 Introduction to the Built Environment -OR- 100140 Computer Aided Drafting	101920 Manufacturing - Woods	101930 Manufacturing Welding (STS) -OR- 016004 Welding (AG)
<b>Man - Construction</b>	100100 Introduction to the Built Environment -OR- 100140 Computer Aided Drafting	101920 Manufacturing - Woods	100110 Principles of Construction Technology (STS)
<b>Man - Metals</b>	100100 Introduction to the Built Environment -OR- 100140 Computer Aided Drafting	101400 Manufacturing - Metals	101930 Manufacturing Welding (STS) -OR- 016004 Welding (AG)
<b>Man - Weld</b>	100100 Introduction to the Built Environment	100140 Computer Aided Drafting	101930 Manufacturing Welding (STS) -OR- 016004 Welding (AG)
<b>Man - PLTW Woods</b>	100161 PLTW Introduction to Engineering Design 		101920 Manufacturing - Woods
<b>Man - PLTW Metals</b>	100161 PLTW Introduction to Engineering Design 		101400 Manufacturing - Metals
<b>Man - PLTW Weld</b>	100161 PLTW Introduction to Engineering Design 		101930 Manufacturing Welding (STS) -OR- 016004 Welding (AG)

Pathway Level Program of Study (POS)

Full Year Course 

Sequence of CTE Courses	Introduction Course	Intermediate Course	Capstone Course
<b>Prod - Standard Woods</b>	100100 Introduction to the Built Environment -OR- 100140 Computer Aided Drafting	101920 Manufacturing - Woods	101921 Advanced Woods Fabrication and Manufacturing
<b>Prod - Engineering Woods</b>	100161 PLTW Introduction to Engineering Design -OR- 103191 Introduction to Engineering	 101920 Manufacturing - Woods	101921 Advanced Woods Fabrication and Manufacturing
<b>Prod - Standard Metals</b>	100100 Introduction to the Built Environment -OR- 100140 Computer Aided Drafting	101400 Manufacturing - Metals	101401 Advanced Metals Fabrication and Manufacturing
<b>Prod - Engineering Metals</b>	100161 PLTW Introduction to Engineering Design -OR- 103191 Introduction to Engineering	 101400 Manufacturing - Metals	101401 Advanced Metals Fabrication and Manufacturing
<b>Prod - Standard Welding</b>	100100 Introduction to the Built Environment -OR- 100140 Computer Aided Drafting	101930 Manufacturing Welding (STS) -OR- 016004 Welding (AG)	101940 Advanced Welding Fabrication and Manufacturing (STS) -OR- 016005 Metals and Fabrication
<b>Prod - Engineering Welding</b>	100161 PLTW Introduction to Engineering Design -OR- 103191 Introduction to Engineering	 101930 Manufacturing Welding (STS) -OR- 016004 Welding (AG)	101940 Advanced Welding Fabrication and Manufacturing (STS) -OR- 016005 Metals and Fabrication
<b>Prod - Standard Plastics</b>	100100 Introduction to the Built Environment -OR- 100140 Computer Aided Drafting	101950 Manufacturing Plastics	101951 Advanced Plastics Fabrication and Manufacturing
<b>Prod - Engineering Plastics</b>	100161 PLTW Introduction to Engineering Design -OR- 103191 Introduction to Engineering	 101950 Manufacturing Plastics	101951 Advanced Plastics Fabrication and Manufacturing
<b>MPPD - Basic Electronics</b>	100100 Introduction to the Built Environment	100401 Introduction to Electronics	100402 Advanced Electronics
<b>MPPD - Basic Mechatronics</b>	100100 Introduction to the Built Environment	100401 Introduction to Electronics	101900 Introduction to Mechatronics

<b>MPPD - Engineering Basic Mechatronics</b>	100161 PLTW Introduction to Engineering Design -OR- 103191 Introduction to Engineering	1 YEAR	100401 Introduction to Electronics	101900 Introduction to Mechatronics
<b>MPPD - Electronics / Mechatronics</b>	100401 Introduction to Electronics		100402 Advanced Electronics	101900 Introduction to Mechatronics
<b>MPPD - Standard Mechatronics with CIM</b>	100100 Introduction to the Built Environment		101901 PLTW Computer Integrated Manufacturing	101900 Introduction to Mechatronics
<b>MPPD - PLTW Standard Mechatronics</b>	100161 PLTW Introduction to Engineering Design -OR- 103191 Introduction to Engineering	1 YEAR	101901 PLTW Computer Integrated Manufacturing	101900 Introduction to Mechatronics

**Tony Glenn**  
 Skilled and Technical Sciences  
 Career Field Specialist







402.471.4819  
 tony.glenn@nebraska.gov  
 www.education.ne.gov/sts





## 2016-2017 Nebraska Career Education Programs of Study

Business, Marketing, and Management Career Field

Finance Cluster

Cluster Level Program of Study (POS)		Full Year Course 	
Sequence of CTE Courses	Introduction Course	Intermediate Course	Capstone Course
Financial Management	030300 Accounting 		030302 College Principles of Accounting -OR- 030301 Advanced Accounting -OR- 033002 College Wealth Building and Financial Management 
Accounting	033000 Personal Finance		030300 Accounting -OR- 030302 College Principles of Accounting 
Academy	033002 College Wealth Building and Financial Management		030302 College Principles of Accounting 
Economics	031800 Business Economics -OR- 151000 Economics		030300 Accounting -OR- 030302 College Principles of Accounting 

Pathway Level Program of Study (POS)		Full Year Course 	
Sequence of CTE Courses	Introduction Course	Intermediate Course	Capstone Course
Accounting	033000 Personal Finance	031800 Business Economics -OR- 151000 Economics	030300 Accounting -OR- 030302 College Principles of Accounting -OR- 033002 College Wealth Building and Financial Management 

<b>AP Economics</b>	033000 Personal Finance	038501 Advanced Placement Microeconomics - OR- 038503 College Microeconomics	038500 Advanced Placement Macroeconomics - OR- 038502 College Macroeconomics
<b>Academy</b>	038501 Advanced Placement Microeconomics - OR- 038503 College Microeconomics	038500 Advanced Placement Macroeconomics - OR- 038502 College Macroeconomics	030302 College Principles of Accounting -OR- 033002 College Wealth Building and Financial Management -OR- 030300 Accounting <span style="float: right; border: 1px solid black; padding: 2px;">1 YEAR</span>

**Bonnie Sibert**

Business, Marketing, and Management  
Career Field Specialist

402.471.4818







bonnie.sibert@nebraska.gov  
www.education.ne.gov/BMIT



**2016-2017 Nebraska Career Education Programs of Study**



Business, Marketing, and Management Career Field

Business, Management and Administration Cluster

Cluster Level Program of Study (POS)	Full Year Course 		
Sequence of CTE Courses	Introduction Course	Intermediate Course	Capstone Course
<b>Accounting</b>	032300 Introduction to Business, Marketing, & Management -OR- 032400 College Introduction to Business	032802 Management and Leadership	030300 Accounting  -OR- 030301 Advanced Accounting -OR-  030302 College Principles of Accounting 
<b>Law</b>	032300 Introduction to Business, Marketing, & Management -OR- 032400 College Introduction to Business	030300 Accounting 	030900 Business Law
<b>Management</b>	032300 Introduction to Business, Marketing, & Management -OR- 032400 College Introduction to Business	032802 Management and Leadership	032370 Entrepreneurship -OR- 032600 College Introduction to Entrepreneurship
<b>Entrepreneurship</b>	032300 Introduction to Business, Marketing, & Management -OR- 032400 College Introduction to Business	030300 Accounting 	032370 Entrepreneurship -OR- 032600 College Introduction to Entrepreneurship
<b>Academy</b>	032400 College Introduction to Business		030302 College Principles of Accounting -OR- 032600 College Introduction to Entrepreneurship 

**Pathway Level Program of Study (POS)**

Full Year Course 

Sequence of CTE Courses	Introduction Course	Intermediate Course	Capstone Course
<b>Accounting</b>	032802 Management and Leadership	032370 Entrepreneurship - OR- 032600 College Introduction to Entrepreneurship	030300 Accounting  -OR- 032400 College Introduction to Business -OR- 030302 College Principles of Accounting 
<b>Academy</b>	032802 Management and Leadership	030300 Accounting 	032400 College Introduction to Business
<b>Business Technology Communications</b>	270501 Information Technology Applications I	270502 Information Technology Applications II	030600 Business Communications
<b>Business Technology Applications</b>	033422 Computer Applications	270501 Information Technology Applications I	270502 Information Technology Applications II

**Approved National Models Program of Study (POS)**

Full Year Course 

National POS	Introduction Course	Intermediate Course	Capstone Course
<b>NAF Academy of Finance</b>	030803 Financial Services	032400 College Introduction to Business	030802 Insurance - OR- 034100 Business in a Global Economy - OR- 030801 Financial Planning -OR- 032370 Entrepreneurship
<b>High School of Business</b>	032300 Introduction to Business, Marketing, & Management	031800 Business Economics	038100 Marketing - AND- 033001 Principles of Finance -AND- 032802 Management and Leadership -AND- 031805 Business Strategies

**Bonnie Sibert**

Business, Marketing, and Management  
Career Field Specialist

402.471.4818

bonnie.sibert@nebraska.gov  
www.education.ne.gov/BMIT

15/16		
courseInfo.courseName	courseInfo.stateCode	courseInfo.terms
Study Hall	1	2
Study Hall	1	2
Study Skills - HS	1	4
Study Hall S Days Only	1	4
Study Hall J Days Only	1	4
Study Hall	1	4
Wellington Attendance	9	4
Introduction to Agriscience	11000 ✓	4
Animal & Crop Production Sci.	<del>11007</del> 011005 / 011008 ✓	4
Agriculture Business	11009 ✓	4
Advanced Horticulture	12001 ✓	2
Horticulture	<del>12002</del> 011007 ✓	2
Natural Resources	13000 ✓	2
Ag Welding & Mechanics	16005 <sup>weld</sup> 016004 / 016005 ✓	4
Interpersonal Skills	17000 <i>what is this / grades</i>	2
SEVENTH AGRISCIENCE	18002 ✓	1
EIGHTH AGRISCIENCE	18002 (Find)	1
Art I	20100 ✓	4
Art II	20200 ✓	4
Art III	20300 ✓	4
Art IV	20400 ✓	4
SEVENTH ART	20800 ✓	1
EIGHTH ART	20801 ✓	1
Art Appreciation	29930 ✓	2
Design	29932 ✓	2
Accounting	30300 ✓	4
Advanced Accounting	30301 ✓	4
General Business	<del>31800</del> 032300 ✓	2
Personal Finance	33000 ✓	2
COMPUTER ETHICS	<del>33422</del> 039930 ✓	1
COMPUTER SCIENCE	33422 ✓	2
SEVENTH KEYBOARDING	33501 ✓	2
English I	50021 ✓	4
English I - A+ Online	<del>50021</del> 059931 ✓	2
English II	50022 ✓	4
English III	50023 ✓	4
English IV	50024 ✓	4
Expository Writing I	<del>50100</del> 059933 ✓	2
Expository Writing II	<del>50100</del> 059934 ✓	2
Creative Writing	50100 ✓	4
Media Literacy	<del>50310</del> 059932 ✓	4
Journalism I	50401 ✓	4
Speech	50501 ✓	2
Speech - D.C.	<del>50501</del> 050502 ✓	2
SEVENTH ENGLISH/READING	50802 ✓	4

032300

EIGHTH ENGLISH/READING	50803	✓	4
Applied English	59930	✓	4
French 1 - DL	60221	✓	4
Spanish I	60241	✓	4
Spanish II (A+ Online)	<del>60242</del> <i>key</i> 60242	✓	4
Spanish II	60242	✓	4
Spanish III	60243	✓	4
EIGHTH GRADE SPANISH	<del>65000</del> 069931		1
SEVENTH GRADE SPANISH	<del>65000</del> 069932		1
Health	80100	✓	2
Advanced Health	80101	✓	2
SEVENTH P.E./HEALTH	<del>80150</del> 089930		4
EIGHTH P.E./HEALTH	<del>80150</del> 089931		4
P.E. I	80200	✓	4
P.E. II	80300	✓	4
Body Conditioning I	80601	✓	4
Body Conditioning II	<del>80601</del> 089932		4
SEVENTH FAMILY TECHNOLOGY	90001	✓	1
EIGHTH FOODS AND NUTRITION	90002	✓	1
Clothing & Fashion	90103	✓	2
Life On Your Own I	90104	✓	2
<del>Foods &amp; Nutrition I</del> <i>Intro to FCS</i>	<del>90107</del> 070101		2
Foods & Nutrition II	90107	✓	2
Housing	90109	✓	2
Parenting	90117	✓	2
<i>child</i> Human Development	90119	✓	2
Building Construction	100120	✓	4
Drafting I	<del>100141</del> ✓ 100130?		4
Drafting II	100141	✓	4
INDUSTRIAL TECHNOLOGY - 7 <sup>th</sup>	100707	✓	1
DRAFTING	<del>100708</del> ?		1
MANUFACTURING TECHNOLOGY - 8 <sup>th</sup>	100708	✓	1
Woods	101920	✓	4
Advanced Woods	101921	✓	4
Advanced Welding	<del>109930</del> 101940		4
SEVENTH PRINCIPLES OF ALGEBRA	<del>110299</del> 112801		4
EIGHTH PRINCIPLES OF ALGEBRA	<del>110299</del> 112802		4
Principles of Algebra	<i>ok</i> 110299	✓	4
Principles of Algebra - Online	110299	✓	2
Algebra I	110300	✓	4
Algebra II (A+ Online)	<i>ok</i> 110306	✓	2
Algebra II	110306	✓	4
Geometry (A+ Online)	<i>ok</i> 111200	✓	2
Geometry	111200	✓	4
Senior Advanced Math	111300	✓	4
Trigonometry, Analytical Geome	111600	✓	4
SEVENTH MATH	112800	✓	4

Choir I	120400	✓	4
Choir II	<del>120400</del>	129932	4
SEVENTH AND EIGHTH CHOIR	<del>120400</del>	120100	4
Show Choir I	120450	✓	4
Show Choir II	120450	129933	4
SEVENTH AND EIGHTH BAND	<del>120500</del>	120100	4
Band I	120500	✓	4
Band II	<del>120500</del>	129934	4
Jazz Band I	120550	✓	4
Jazz Band II	<del>120550</del>	1299301	4
Music Appreciation	129930	✓	4
Music Theory & History	129930	<del>120550</del> ✓ <del>129930</del>	4
Basic Biology	<del>130201</del>	139930	4
Biology	130201	✓	4
Advanced Biology	130202	✓	4
Physical Science - A+ Online	130300	✓	2
Basic Physical Science	<del>130300</del>	139931	4
Physical Science	130300	✓	4
Chemistry	130301	✓	4
Chemistry Lab J Days Only	<del>130301</del>	139932	4
Physics	130303	✓	4
S.T.E.M.	130304	✓	4
<del>Earth Science</del> <i>Geo Science</i>	130415	✓	4
SEVENTH SCIENCE	130801	✓	4
EIGHTH SCIENCE	130802	✓	4
WORLD GEOGRAPHY/CIVICS RR7	150011	150104?	4
WORLD GEOGRAPHY/CIVICS	150011	✓	4
EIGHTH AMERICAN HISTORY	150012	✓	4
AMERICAN HISTORY RR8	<del>150012</del>	<del>150012</del> 159932	4
World Geography	150700	✓	4
History of the World I (A+)	<del>150800</del>	159931 *	4
World History	150800	✓	4
Nebraska History	150810	✓	2
American History	150820	✓	4
Economics	151000	✓	2
Economics	151000	why 2 ?	2
American Government	151110	✓	4
Basic Am Government/History <i>Civics</i>	151114	✓	4
Intro to Psychology - MPCC	151200	✓	2
Intro to Psychology - Online	151200	✓	2
Life Applications	159930	✓ *	4
Life Skills Language JH	<del>190530</del>	190515	4
Life Skills English	190530	✓	4
Life Skills Math	191130	✓	4
Life Skills Music	191230	✓	4
Life Skills Science	191330	✓	4
Life Skills - Current Events	<del>191530</del>	171515	4

Life Skills Social Studies	191530	✓	4
Life Skills Health	192000	✓	4
Life Skills Keyboarding	OK 192000	✓	4
Life Skills Personal Finance	192000	✓	4
Life Skills Cooking	192015	✓	4
Driver Education	210105	✓	1
Secondary TA - J days only	230800	✓	4
Secondary Teacher Aide - Year	OK 230800	✓	4
Secondary TA - S days only	230800	✓	4
Secondary Teacher Aide - Sem	230800	✓	4
NeSA Prep	260300	✓	4
Information Technology I	270501	✓	2
Information Technology II	270502	✓	2
Media Production	270609	✓	4
ELL Rosetta Stone	310010	✓	4
ELL Writing	<del>310051</del> 310101	✓	4
ELL Newcomers English JH	310051	✓	4
ELL Language Acquisition JH	310051	✓	4
ELL Reading	<del>310051</del> 310101	✓	4
ELL Language Acquisition HS	310051	✓	4
ELL American History	310151	✓	4
EIGHTH CAREERS/CURRENT EVENTS	320400	159934	2
Diversified Occupations	320700	✓	4
D.O. Work Experience	320700	✓	4
Pro Start I	370030	✓	4
JH GIRLS BASKETBALL	999999		0
Life Skills Math JH			4
Advisory			4
Study Skills - Junior High			4
Life Skills English JH			4
Life Skills Reading JH			4
Life Skills Adapted PE JH			4
Life Skills Adapted PE			4
Life Skills Science JH			4
Life Skills Health JH			4
Life Skills Social Studies JH			4
ELL JH AMERICAN HISTORY			4
Eligibility			0
Title I			0
7th Study Skills			2
Street Law			2
Teen Issues			2
Life Skills Work Exploration			4
Life Skills Art			4
Life Skills Woods			4
Life Skills Job Skills			4
Early Grad			1

14/17

courseInfo.courseName	courseInfo.stateCode	courseInfo.terms
Study Hall	1	2
Study Hall	1	2
Study Skills - HS	1	4
Study Hall S Days Only	1	4
Study Hall J Days Only	1	4
Study Hall	1	4
Wellington Attendance	9	4
Introduction to Agriscience	11000	4
Animal & Crop Production Sci.	11007	4
Agriculture Business	11009	4
Advanced Horticulture	12001	2
Horticulture	12002	2
Natural Resources	13000	2
Ag Welding & Mechanics	16005	4
Interpersonal Skills	17000	2
Art I	20100	4
Art II	20200	4
Art III	20300	4
Art IV	20400	4
Art Appreciation	29930	2
Design	29932	2
Accounting	30300	4
Business Law	30900	2
Intro to Business	31800	2
Personal Finance	33000	2
Basic English I	50021	4
English I	50021	4
Basic English II	50022	4
English II	50022	4
English III	50023	4
English IV	50024	4
Expository Writing I	50100	2
Expository Writiing II	50100	2
Creative Writing	50100	4
Media Literacy	50310	4
Journalism I	50401	4
Speech - D.C.	50501	2
Spanish I	60241	4
Spanish II	60242	4
Spanish III	60243	4
Spanish IV	60244	4
Spanish Culture	69930	4
Health	80100	2
Advanced Health	80101	2
P.E. I	80200	4
Body Conditioning	80601	4

Check separate →

Clothing & Fashion		90103		2
Life on Your Own II	*	90104	090108	2
Life On Your Own I		90104		2
Foods & Nutrition I		<del>90107</del>		2
Foods & Nutrition II		90107		2
Housing		90109		2
Parenting		90117		2
Human Development		90119		2
Teen Issues	? *	<del>99930</del>	?	2
Drafting III		<del>100120</del>	10.0140	4
Building Construction	2 per. Split	100100 / 100120		4
Drafting I		100141	100130	4
Drafting II		100141		4
Woods		101920		4
Advanced Woods		101921		4
Advanced Welding		<del>109930</del>	101940	4
Principles of Algebra		110299		4
Algebra I		110300		4
Algebra II		110306		4
College Algebra - D.C.	*	110622	✓	2
Geometry		111200		4
Senior Advanced Math		111300		4
Trigonometry, Analytical Geome		111600		4
ACT Math Prep	*	119930	✓	2
Choir I		120400		4
Choir II		120400		4
Show Choir I		120450		4
Show Choir II		120450		4
Band I		120500		4
Band II		120500		4
Jazz Band I		120550		4
Jazz Band II		120550		4
Music Appreciation		129930		4
Music Theory & History		129930		4
Garage Band	* Not Using	129931		4
Basic Biology		130201		4
Biology		130201		4
Advanced Biology		130202		4
Basic Physical Science		130300		4
Physical Science		130300		4
Chemistry		130301		4
Chemistry Lab		130301		4
Physics		130303		4
S.T.E.M.		130304		4
Earth Science		130415		4
World Geography		150700		4
World History		150800		4

Nebraska History		150810		2
American History		150820	}	4
American History II	*	150820		4
Macroeconomics	X	151000	}	2
Microeconomics	X	151000		2
American Government		151110		4
Basic Am Government/History		151114		4
Intro to Psychology - MPCC		151200		2
Street Law	*	159930	151103	2
Life Skills Art	*	190215		4
Life Skills English JH		190515		4
Life Skills Language JH		190530	}	4
Life Skills Reading JH		190530		4
Life Skills English		190530		4
Life Skills Math JH	*	191115		4
Life Skills Math		191130	✓	4
Life Skills Music		191230	✓	4
Life Skills Science JH	*	191315	✓	4
Life Skills Science		191330	✓	4
Life Skills Social Studies JH	*	191515	✓	4
Life Skills - Current Events		191530	✓	4
Life Skills Social Studies		191530	✓	4
Life Skills Health		192000	✓	4
Life Skills Keyboarding		192000	✓	4
Life Skills Personal Finance		192000	✓	4
Life Skills Health JH		192000	✓	4
Life Skills Cooking		192015	✓	4
Life Skills Adapted PE	*	193000	✓	4
Driver Education		210105	✓	2
Theater	*	220100	✓	4
Secondary TA - J days only		230800	✓	4
Secondary Teacher Aide - Year		230800	✓	4
Secondary TA - S days only		230800	✓	4
Secondary Teacher Aide - Sem		230800	✓	4
Information Technology I		270501	✓	2
Information Technology II		270502	✓	2
Media Production		270609	✓	4
ELL Language Acquisition HS		310051	✓	4
Pro Start I		370030	✓	4
Intervention/Mentoring				4
Early Grad				1
Life Skills Job Skills				4
Life Skills Work Exploration				4
Life Skills Woods				4
Eligibility				0
Title I				0
Basic Algebra II				4





**PEPSICO**



**Foodservice**

**Joe Urbanec**  
**308-380-2441**  
**Chase County High School**



**PEPSICO**



**Tropicana**



**The PepsiCo Foodservice Team is very excited to have this opportunity to present a proposal to you for your total beverage needs.**

**You will find in the enclosed proposal from the PepsiCo Foodservice:**

- ***Service Commitment***
- **Market Share Information**
- **Brand Lineup**
- **Pricing**
- **Summary**



**PEPSICO**



**Tropicana**



# The Brand Consumers Prefer

# #1



National Bottled Water



Iced Tea



Ready to Drink Coffee



**SOBE**

Healthy Refreshment Beverage



**SERIES**

Sports Drink



Flavored CSD

# Tropicana

100% Juice



**PEPSICO**



**Tropicana**



# Market Share Shows Consumer

2012 Market Share: BEVERAGE

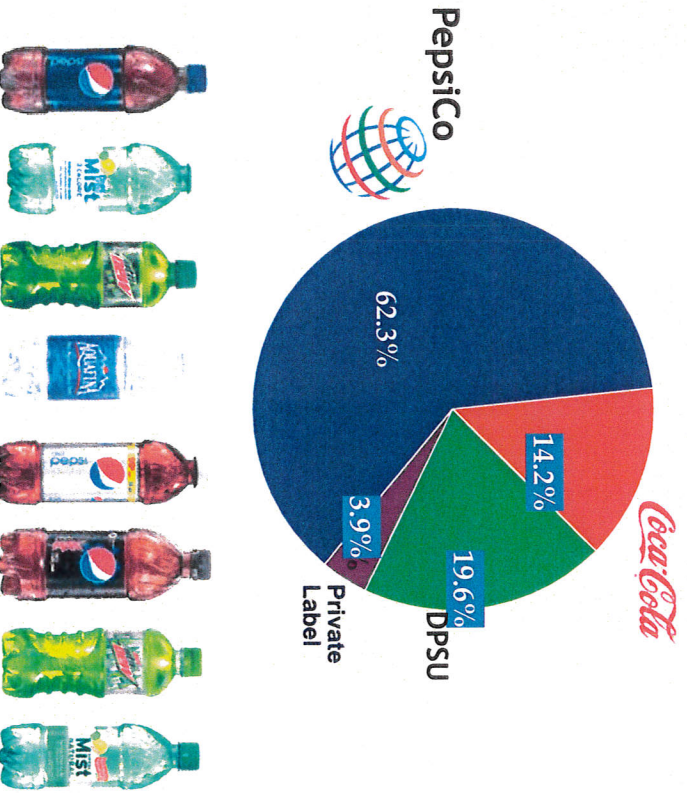

2012 Market Share: SNACKS

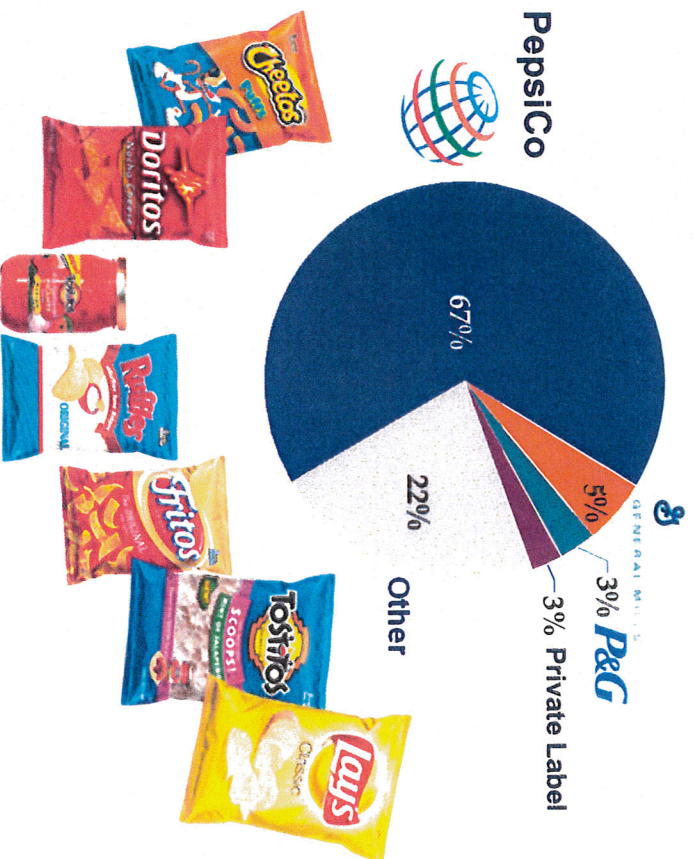



**PEPSICO**



**Tropicana**



*Kickstart  
12oz cans*

# Boost Beverage Sales with the Best Bottle Lineup

- Pepsi can help you understand the **profitability opportunity** for YOUR business, and provide tools – such as **point of sale materials** – to effectively **add sales** and **increase beverage incidence.**





**PEPSICO**



**Tropicana**



# Our Snack Portfolio Addresses The Entire Spectrum of Consumer Snacking Demand Moments

## Frito Lay North America

**On the Go Energy**



**Snacking**



**Young and Hungry**



**Healthy Enjoyment**

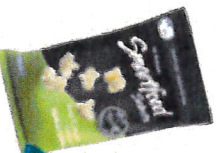

These items and many other products can be purchased through your food provider (Sysco, US Foods, etc.)

# PEPSI FOODSERVICE PRODUCT PORTFOLIO

## GATORADE

**20 oz. PLASTIC BOTTLES - 24/cs**

Cool Blue Raspberry / Fierce Grape / Fruit Punch / Lemon Lime / Orange / Riptide Rush Grape / Glacier Freeze / Cherry



## GATORADE G2

**20 oz. PLASTIC BOTTLES - 24/cs**

Grape / Fruit Punch



## GATORADE PROPEL

**20 oz. PLASTIC BOTTLES - 24/cs**

Berry / Grape / Kiwi Strawberry /



## OCEAN SPRAY

**15.2oz PLASTIC BOTTLE - 12/cs**

Orange Juice / Apple Juice / Cranberry Cocktail / CranGrape / Ruby Red Grapefruit Cran Lemonade / Diet Cranberry



## SOBE LIFE WATER - 0 CALORIE

**20oz PLASTIC BOTTLE - 12/cs**

Yumberry Pomegranate / Fuji Apple Pear / Black and Blueberry / Blood Orange / Acai Ras Punch / Blood Orange/Strawberry Dragonfruit / **B-Energy Black Cherry Dragonfruit** / Strawberry Apricot / **80 Cal Coconut Water** Pacific Coconut / Mango Mandarin / Pomegranate Nectarine **40 Cal** Pomegranate Cherry Strawberry Kiwi / Blackberry Grape



## SOBE

**20oz PLASTIC - 12/cs**

Energy / Green Tea / Pina Colada / Strawberry Banana / Strawberry Daiquiri / Mango Melon / Lean Honey Green Tea / Lean Raspberry Lemonade



## ENERGY DRINKS

**16oz CAN - 12/cs.**

### Mt. Dew Amp

Amp / Amp Sugar Free / Overdrive (Cherry) / Elevate (Mixed Berry) / Traction (Grape) / Lightning (Lemonade)



**16oz CAN - 24/cs.**

### Rockstar

Original / Sugar Free / Zero Carb / Punched / Recovery / Recovery Orange Recovery Grape / 2X / Coconut Water Energy / Xdurance / ICED / Relax / Energy Cola / Juiced Mango-Orange Passion Fruit / Juiced Guava/ Sour Bubble Berry & Green Apple / Sparkling Energy Cherry Citrus / Peach



## MT. Dew Kick Start

**16oz Can - 12/cs.**

Orange Citrus / Fruit Punch / Lemonade / Black Cherry



## SCHWEPPES MIXERS

**20oz BOTTLES**

Original/Black Cherry/Lemon Lime

**1 L PLASTIC BOTTLES 12/cs**

Club Soda / Tonic

**2 L PLASTIC BOTTLES 8/cs**

Ginger Ale

**10oz PLASTIC BOTTLES 6/cs**

Club Soda / Tonic

**12oz CAN 12pk 2/cs**

Ginger Ale



## STARBUCKS FRAPPUCCINO



**9.5oz GLASS BOTTLE - 24/cs.**

Coffee / Mocha / Vanilla / Mocha and Vanilla Lite / Caramel

**13.7oz GLASS BOTTLE - 12/cs.**

Dark Chocolate Mocha / Mocha / Vanilla

**6.5oz CAN - 24 /cs.**

Double Shot

**Double Shot Energy**

**15oz CAN - 12/cs.**

Coffee / Mocha / Vanilla / Vanilla Light / White Chocolate / Hazelnut



## Refreshers

**12oz CAN - 12/cs.**

Raspberry Pomegranate Strawberry Lemonade Orange Melon Blueberry Acai



## Iced Coffee

**11oz 12/cs.**

Coffee & Milk, Coffee & Milk Low Calorie, Vanilla



## Rock star Roasted

**15oz CAN - 12/cs.**

Mocha, Light Vanilla, Latte

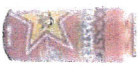

\*Packages displayed do not necessarily reflect current package designs

## SOFT DRINK AND TEA FLAVORS



### **12oz Cans 24/cs.**

Pepsi / Diet Pepsi / Pepsi Next / Pepsi Max / Pepsi Caffeine Free / Dt. Pepsi Caffeine Free / Pepsi Throwback / Mt. Dew / Mt. Dew Throwback / Wild Cherry / Diet Wild Cherry / Diet Mt Dew / Crush Orange / Crush Cherry / Crush Grape / Crush Strawberry / Dt. Crush Orange / Sierra Mist Natural / Dt. Sierra Mist Natural / Mug / Dt. Mug / Lipton Brisk Lemonade / Lipton strawberry Melon / Lipton Brisk Raspberry / Lipton Brisk Sweet Tea / Lipton Brisk Sweetened with Lemon

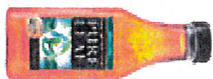

### **Pure Leaf Tea**

#### **18.5 OZ Plastic Bottle**

Sweet / Unsweetened / Extra Sweet / Raspberry/ Peach/ Green Tea Honey



### **Aquafina Water**

#### **12oz Plastic 24/cs.**

#### **20oz Plastic 24/cs.**

#### **1 Litter Plastic 12/cs.**

#### **1.5 Litter Plastic 12/cs.**

### **AQUAFINA FLAVOR SPLASH WATER**

#### **20 oz. PLASTIC BOTTLES - 24/cs.**

Grape / Raspberry / Wild Berry



### **LIPTON TEA**

#### **20 oz Plastic Bottle**

Green Tea Citrus / Diet Green Tea Citrus / Black Tea Lemon / Tea & Lemonade (Half & Half) / Black Tea Peach

### **FRUIT SHOOT**

#### **10.1oz 1/24**

Orange / Berry Burst / Strawberry/Raspberry / **No Added Sugar** Apple / Straw/Rasp / Orange



### **20 oz. PLASTIC BOTTLES - 24/cs.**

Pepsi / Diet Pepsi / Pepsi Next / Dt. Pepsi Caffeine Free / Pepsi Max / Wild Cherry / Dt. Wild Cherry / Pepsi Throwback / Mt. Dew / Dt. Mt. Dew / Mt. Dew Code Red (Cherry) / Mt. Dew Live Wire (Orange) / Mt. Dew Voltage (Raspberry) / Mt. Dew White Out Mt, Dew Throwback / Crush Orange / Crush Grape / Crush Strawberry / Dt. Crush Orange / Sierra Mist Natural / Dt. Sierra Mist Natural / Mug / Lipton Brisk Lemonade / Lipton Brisk Sweetened with Lemon / Sierra Mist Cranberry / Dt. Sierra Mist Cranberry



### **12 oz. PLASTIC BOTTLES - 24/cs.**

Pepsi / Diet Pepsi / Dt. Caffeine Free / Mt. Dew / Diet Mt Dew / Crush Orange / Sierra Mist Natural



### **1 LITER PLASTIC BOTTLES - 12/cs.**

Pepsi / Diet Pepsi / Mt. Dew / Lipton Brisk Lemonade / Lipton Brisk Straw Melon / Schweppes Tonic / Schweppes Club Soda / Brisk Half & Half Tea and Tropical Lemonade / Brisk Half & Half Tea and Cherry Lemonade



### **2 LITER PLASTIC BOTTLES - 8/cs.**

Pepsi / Diet Pepsi / Pepsi Max / Pepsi Caffeine Free Pepsi Next / Wild Cherry Pepsi / Dt. Wild Cherry Pepsi Mt. Dew / Dt. Mt. Dew / Orange Crush / Grape Crush / Strawberry Crush / Lipton Brisk Lemonade / Lipton Brisk Straw Melon / Mug / Sierra Mist Natural / Dt. Sierra Mist / Sierra Mist Cranberry / Dt. Sierra Mist Cranberry

### **Brisk Tea**

#### **24oz CAN - 12/cs.**

Honey Ginseng Tea, Mango Tea, Strawberry Melon, Tea W/ Lemon, Raspberry Tea, Tea & Lemonade, Sweet Tea Fruit Punch





**PEPSICO**



**Tropicana**



# Profits From Beverage Sales

## Proposal Elements

PRODUCT	ON TICKET	Rebates
CSD <sup>8oz</sup>	\$23.78	\$5.00
Aquafina	\$ 23.78	\$5.00
Gatorade <sup>20oz</sup>	\$ 28.44	\$4.00
Kick Start <sup>12oz</sup>	\$ 14.03	\$1.00

Product	Cost per Case after rebate	Cost per Unit	Retail	Profit per case
20 oz CSD	23.78	.99	\$2.00	\$20.62
20 oz Water	23.78	.99	\$2.00	\$20.62
20 oz Gatorade	28.44	1.19	\$2.00	\$19.56
Kick start	13.69	1.14	\$2.00	\$10.31



**PEPSICO**



**Tropicana**



## Partnership

Pepsi would like to enter into the following Proposal

### Proposal Elements

5 Year contract

\$ 5000 for new gym signage *(can be 5 case boards)*

Volume hurdle for 5 years is 3125 cases

\$ 3000 Dollars per year

\$400 a year for 5 years for Gatorade sideline kit



**PEPSICO**



**Tropicana**



**THANK YOU**

# Chase County Public Schools



*Coca-Cola*

Classified

## Chase County Schools

## Presentation Purpose

Chesterman Coca-Cola would like to begin by sincerely thanking the Chase County Public Schools for affording us the opportunity to make this presentation. We are enthusiastically looking forward to serving you for many years to come.

It is the specific intent of this proposal to provide a foundation from which we can build our mutually beneficial relationship.

Coca-Cola Representative

Matt Sale (308) 520-3357



Classified

## Chase County Schools

## Sponsorship and Pricing

Proposal for Coca Cola to be exclusive at all Chase County Public School events and properties for 5 years.

### Sponsorship

- ✓ \$1,500 annual payment (\$7,500 over life of agreement)

Pricing (pricing guaranteed for one year, then subject to 3% increase annually on anniversary date of agreement)

- ✓ CSD 20oz-Dead Net \$19.92 per case
- ✓ Dasani 20oz-Dead Net \$10.32per case
- ✓ PowerAde 20oz-\$20.95 Dead Net per case

### Equipment

Chesterman Coca Cola will provide equipment needed to serve Coca Cola Beverages at no cost to Chase County Schools. Volume of equipment is based on volume of product sold. 5 pieces of equipment is our recommendation.



Classified

## Chase County Schools

---

We again thank you for the opportunity to be the beverage supplier of the Chase County Public Schools.

### Coca-Cola Representative

Matt Sale (308) 520-3357 - [Msale@chesterman.com](mailto:Msale@chesterman.com)

### Next Steps:

- \* Agree in principal
- \* Draft and sign contract
- \* Implement proposal



Classified

## 2016-2017 Substitute Schedule

Base\$      \$ 33,850.00    BaseDays      184

### Certified Subs

Day 1	\$ 114
Day 4-20	\$ 132
Day 21+	\$ 160

### Local Certificate Subs

Day 1	\$ 103
Day 4-20	\$ 119
Day 21+	\$ 144

Period Substitute      \$ 16

*All calculations based on Board Policy GCB.*

### Bus Driver Substitute

Route      \$ 39

*See Board Motion to increase with Bus Step 1.  
(Step 1 annual salary/contract days)/2  
routes/day=\$/route)*

Activity      \$ 13.50

2016 Mileage (IRS)      \$ 0.540

*Note: 2017 Mileage (IRS) applied 1/1/2017.*

### Substitutes - Other

Instructional	\$ 8.50
Kitchen	\$ 8.50
ELL	\$ 8.50
Office	\$ 8.50
SPED	\$ 9.50
SPED (level1)	\$ 9.50
Nurse (non-certified)	\$ 9.00
Bus Dispatch	\$ 9.00
Custodian	\$ 10.00

## 2016-2017 Substitute Schedule

Base\$      \$ 33,850.00    BaseDays      184

### Certified Subs

Day 1	\$ 114
Day 4-20	\$ 132
Day 21+	\$ 160

### Local Certificate Subs

Day 1	\$ 103
Day 4-20	\$ 119
Day 21+	\$ 144

Period Substitute      \$ 16

*All calculations based on Board Policy GCB.*

### Bus Driver Substitute

Route      \$ 39

*See Board Motion to increase with Bus Step 1.  
(Step 1 annual salary/contract days)/2  
routes/day=\$/route)*

Activity      \$ 13.50

2016 Mileage (IRS)      \$ 0.540

*Note: 2017 Mileage (IRS) applied 1/1/2017.*

### Substitutes - Other

Instructional	\$ 8.50
Kitchen	\$ 8.50
ELL	\$ 8.50
Office	\$ 8.50
SPED	\$ 9.50
SPED (level1)	\$ 9.50
Nurse (non-certified)	\$ 9.00
Bus Dispatch	\$ 9.00
Custodian	\$ 10.00

*Desktop  
↳ August - Back to School  
↳ 16-17 Sub. Pay Sch.*

## STUDENT FEES

The Board of Education of Chase County Schools adopts the following student fees policy in accordance with the Public Elementary and Secondary Student Fee Authorization Act.

The District's general policy is to provide for the free instruction in school in accordance with the Nebraska Constitution and state and federal law. This generally means that the District's policy is to provide free instruction for courses which are required by state law or regulation and to provide the staff, facility, equipment, and materials necessary for such instruction, without charge or fee to the students.

Under the Public Elementary and Secondary Student Fee Authorization Act, the District is required to set forth in a policy its guidelines or policies for specific categories of student fees. The District does so by setting forth the following guidelines and policies. This policy is subject to further interpretation or guidance by administrative or Board regulations which may be adopted from time to time. The Policy includes Appendix "1", which provides further specifics of student fees and materials required of students. Parents, guardians, and students are encouraged to contact their building administration or their teachers or activity coaches and sponsors for further specifics.

- 1) Guidelines for non-specialized attire required for specified courses and activities. Students have the responsibility to furnish and wear non-specialized attire meeting general District grooming and attire guidelines, as well as grooming and attire guidelines established for the building or programs attended by the students or in which the students participate. Students also have the responsibility to furnish and wear non-specialized attire reasonably related to the programs, courses and activities in which the students participate where the required attire is specified in writing by the administrator or teacher responsible for the program, course or activity.

The District will provide or make available to students such safety equipment and attire as may be required by law, specifically including appropriate industrial-quality eye protective devices for courses of instruction in vocational, technical, industrial arts, chemical or chemical-physical classes which involve exposure to hot molten metals or other molten materials, milling, sawing, turning, cutting, grinding, or stamping of any solid materials, heat treatment, tempering, or kiln firing of any metal or other materials, gas or electric arc welding or other forms of welding processes, repair or servicing of any vehicle, or caustic or explosive materials, or for laboratory classes involving caustic or explosive materials, hot liquids or solids, injurious radiations, or other similar hazards. Building administrators are directed to assure that such equipment is available in the appropriate classes and areas of the school building, teachers are directed to instruct students in the usage of such devices and to assure that students use the devices as required, and students have the responsibility to follow such instructions and use the devices as instructed.

[← Back to Section J](#)

[← Back to Table of Contents](#)

## 2) Personal or consumable items & miscellaneous

(a) Extracurricular Activities. Students have the responsibility to furnish any personal or consumable items for participation in extracurricular activities.

### (b) Courses

(i) General Course Materials. Items necessary for students to benefit from courses will be made available by the District for the use of students during the school day. Students may be encouraged, but not required, to bring items needed to benefit from courses including, but not limited to, pencils, paper, pens erasers, notebooks, trappers, protractors and math calculators. A specific class supply list will be published annually in a Board-approved student handbook or supplement or other notice. The list may include refundable damage or loss deposits required for usage of certain District property.

(ii) Damaged or Lost Items. Students are responsible for the careful and appropriate use of school property. Students and their parents or guardian will be held responsible for damages to school property where such damage is caused or aided by the student and will also be held responsible for the reasonable replacement cost of school property which is placed in the care of and lost by the student.

(iii) Materials Required for Course Materials. Students are permitted to and may be encouraged to supply materials for course projects. Some course projects (such as projects in art and shop classes) may be kept by the student upon completion. In the event the completed project has more than minimal value, the student may be required, as a condition of the student keeping the completed project, to reimburse the District for the reasonable value of the materials used in the project. Standard project materials will be made available by the District. If a student wants to create a project other than the standard course project, or to use materials other than standard project materials, the student will be responsible for furnishing or paying the reasonable cost of any such materials for the project.

(iv) Music Course Materials. Students will be required to furnish musical instruments for participation in optional music courses. Use of a musical instrument without charge is available under the District's fee waiver policy. The District is not required to provide for the use of a particular type of musical instrument for any student.

(v) Parking. Students may be required to pay for parking on school grounds or at school-sponsored activities, and may be subject to payment of fines or damages for damages caused with or to vehicles for failure to comply with school parking rules.

3) Extracurricular Activities - Specialized Equipment or Attire. Extracurricular activities means student activities or organizations which are supervised or administered by the District, which do not count toward graduation or

← [Back to Section J](#)

← [Back to Table of Contents](#)

advancement between grades, and in which participation is not otherwise required by the District. The District will generally furnish students with specialized equipment and attire for participation in extracurricular activities. The District is not required to provide for the use of any particular type of equipment or attire. Equipment or attire fitted for the student and which the student generally wears exclusively, such as dance squad, cheerleading, and music/dance activity (e.g. choir or show choir) uniforms and outfits, along with T-shirts for teams or band members, will be required to be provided by the participating student. The cost of maintaining any equipment or attire, including uniforms, which the student purchases or uses exclusively, shall be the responsibility of the participating student. Equipment which is ordinarily exclusively used by an individual student participant throughout the year, such as golf clubs, softball gloves, and the like, are required to be provided by the student participant. Items for the personal medical use or enhancement of the student (braces, mouth pieces, and the like) are the responsibility of the student participant. Students have the responsibility to furnish personal or consumable equipment or attire for participation in extracurricular activities or for paying a reasonable usage cost for such equipment or attire. For musical extracurricular activities, students may be required to provide specialized equipment, such as musical instruments, or specialized attire, or for paying a reasonable usage cost for such equipment or attire.

- 4) Extracurricular Activities - Fees for Participation. Any fees for participation in extracurricular activities are further specified in Appendix "1". Admission fees are charged for extracurricular activities and events.
- 5) Post-secondary Education Costs. Students are responsible for postsecondary education costs. The phrase "postsecondary education costs" means tuition and other fees only associated with obtaining credit from a postsecondary educational institution. For a course in which students receive high school credit and for which the student may also receive postsecondary education credit, the course shall be offered without charge for tuition, transportation, books, or other fees, except tuition and other fees associated with obtaining credits from a postsecondary educational institution.
- 6) Transportation Costs. Students are responsible for fees established for transportation services provided by the District as, and to the extent, permitted by federal and state laws and regulations.
- 7) Copies of Student Files or Records. The Superintendent or the Superintendent's designee shall establish a schedule of fees representing a reasonable cost of reproduction for copies of a student's files or records for the parents or guardians of such student. A parent, guardian or student who requests copies of files or records shall be responsible for the cost of copies reproduced in accordance with such fee schedule. The imposition of a fee shall not be used to prevent parents of students from exercising their right to inspect and review the student's files or records. The fee schedule shall permit one copy of the requested records be provided for or on behalf of the student without charge and shall allow duplicate

[← Back to Section J](#)

[← Back to Table of Contents](#)

copies to be provided without charge to the extent required by federal or state laws or regulations.

- 8) Participation in Before-and-After-School or Pre-kindergarten Services. Students are responsible for fees required for participation in before-and-after-school or pre-kindergarten services offered by the District, except to the extent such services are required to be provided without cost.
- 9) Participation in Summer School or Night School. Students are responsible for fees required for participation in summer school or night school. Students are also responsible for correspondence courses.
- 10) Breakfast and Lunch Programs. Students shall be responsible for items which students purchase from the District's breakfast and lunch programs. The cost of items to be sold to students shall be consistent with applicable federal and state laws and regulations. Students are also responsible for the cost of food, beverages, and personal or consumable items which the students purchase from the District or at school, whether from a "school store," a vending machine, a booster club or parent group sale, a book order club, or the like. Students may be required to bring money or food for field trip lunches and similar activities.
- 11) Waiver Policy. The District's policy is to provide fee waivers in accordance with the Public Elementary and Secondary Student Fee Authorization Act. Students who qualify for free or reduced-price lunches under United States Department of Agriculture child nutrition programs shall be provided a fee waiver or be provided the necessary materials or equipment without charge for: (1) participation in extracurricular activities and (2) use of a musical instrument in optional music courses that are not extracurricular activities. Participation in a free lunch program or reduced-price lunch program is not required to qualify for free or reduced-price lunches for purposes of this section. Students or their parents must request a fee waiver prior to participating in or attending the activity, and prior to purchase of the materials.
- 12) Distribution of the Policy. The Superintendent or the Superintendent's designee shall publish the District's student fee policy in the Student Handbook or the equivalent (for example, publication may be made in an addendum or a supplement to the student handbook). The Student Handbook or the equivalent shall be provided to students of the District or to every household in which at least one student resides, at no cost.
- 13) Student Fee Fund. The School Board hereby establishes a Student Fee Fund. The Student Fee Fund shall be a separate school district fund not funded by tax revenue, into which all money collected from students and subject to the Student Fee Fund shall be deposited and from which money shall be expended for the purposes for which it was collected from students. Funds subject to the Student Fee Fund consist of money collected from students for: (1) participation in extracurricular activities, (2) postsecondary education costs, and (3) summer school or night school.

Legal References:

Neb. Rev. Stat. §§72-2,125 to 7-2,135 and Laws 2003, LB 249 (The Public Elementary and Secondary Student Fee Authorization Act)  
Neb. Constitution, Article VII, Section 1  
Neb. Rev. Stat. §§79-241, 79-605, and 79-611 (transportation)  
Neb. Rev. Stat. §79-2,104 (student files or records)  
Neb. Rev. Stat. §79-715 (eye-protective devices)  
Neb. Rev. Stat. §79-737 (liability of students for damages to school books) Neb. Rev. Stat. §79-1104 (before-and-after-school or pre-kindergarten services)  
Neb. Rev. Stat. §§79-1106 to 79-1108.03 (accelerated or differentiated curriculum program)

Business OperationsSale and Disposal of School Property

The Superintendent is authorized and directed to dispose of books, furniture, equipment, real estate, and other property that is obsolete or no longer needed for school operations. Any sale of school property is contingent on approval by the vote of at least two-thirds of the members of the Board of Education at a regular meeting.

Such disposal may be by private sale, auction, trade-in, or by taking bids and selling to the highest or most responsible bidder.

The following procedures shall be followed for an auction or when taking bids:

1. The intention to sell shall be publicized, via school newsletter, a weekly memo, a bulletin posting, a newspaper advertisement, or other means suitable to the value and nature of the property.
2. Real estate will be sold to the highest bidder, except that a minimum acceptable price may be established prior to bidding.
3. Items which are offered for sale in an approved manner which are not sold after a reasonable period of time may be considered to have no value and may be disposed of as determined by the Superintendent and reported to the Board of Education.

Property that has little or no value shall be discarded or recycled as appropriate. No school employee shall take such property for their personal use, even if the item has been placed in the trash, without the express approval of the administration.

Legal Reference: Neb. Rev. Stat. § 79-10,114

Date of Adoption: [Insert Date]

Business OperationsPurchasing Policies

The Superintendent shall ensure that all purchases are made in the interest of economy and efficiency. Where necessary, standards and procedures shall be established to accomplish the following policies of the Board of Education:

1. Purchases up to \$5,000. For the greatest efficiency in expediting purchases, the administration shall be authorized to purchase any item specifically budgeted which has a sale price within the established limit.
2. Purchases from \$5,000 up to \$40,000. The Superintendent shall request the submission of proposals for purchases which have a sale price within the established limit. The Superintendent shall receive and evaluate all proposals in making a recommendation to the Board of Education for acceptance. The Board of Education may review all proposals submitted relating to the recommended purchase. Since this is a proposal system, not a bidding process, the school district in no way shall be obligated to arbitrarily award the contract to the lowest proposal, but shall reserve the right to reject any and all proposals or to waive any informality in any proposal it deems advisable, and to award to the proposer which, in its opinion, is most desirable.
3. Purchases of \$40,000 and above. The Superintendent shall advertise for sealed bids which shall be opened in conformity with any applicable laws and in compliance with any procedures established by the Superintendent. The Board retains the right to determine the responsibility of the bidders, and shall award the contract to the lowest responsible bidder meeting specifications, be the bidder a member or apart from the local community.
4. Any school employee who orders any supplies or equipment outside of that which has been included in the annual budget and without written authorization of the principal or superintendent shall be personally liable for payment for the supplies or equipment purchased.
5. School employees or students purchasing supplies and equipment out of an activity account must first secure a purchase order from the principal authorizing the purchase. Failure to do so will cause the person to be personally liable for payment for the supplies or equipment purchased.

Credit Card Purchasing Program

1. The Board of Education authorizes the Superintendent or designee to contract with one or more financial institutions, card-issuing banks, credit card companies, charge card companies, debit card companies, or third-party merchant banks capable of operating a purchasing card program on behalf of the District.

2. The Board of Education delegates to the Superintendent or designee: (a) the determination of the type of purchasing card or cards to be utilized in the District's purchasing card program; and (b) the determination of which employees shall be approved or disapproved to be assigned a purchasing card in the District's purchasing card program. The Superintendent shall submit the approved names to the Board, from time to time.
3. The District's purchasing card program may only be utilized for the purchase of goods and services for and on behalf of the District. No officer or employee of the District shall use a purchasing card for any unauthorized use.
4. An itemized receipt for purposes of tracking expenditures shall accompany all purchasing card purchases. In the event that a receipt does not accompany an authorized cardholder's purchase, the Superintendent or designee shall temporarily or permanently suspend said cardholder's purchasing card privileges.
5. Upon the termination or suspension of employment of an individual using a purchasing card, the Superintendent or designee shall immediately close such individual's purchasing card account and said employee shall immediately return the purchasing card.

Legal Reference: Neb. Rev. Stat. § 13-610

Date of Adoption: [Insert Date]

Business OperationsESSA

It is the policy of the District to comply with the Every Student Succeeds Act (“ESSA”) and federal grant programs in which the District participates.

1. Authority to Sign Applications. The Superintendent is authorized to sign applications for any of the ESSA formula grants on behalf of the District and may delegate such authority to other administrators in the Superintendent’s discretion. The Superintendent shall submit such applications as determined appropriate so long as acceptance of the funds does not include conditions contrary to the policies of the Board of Education.
2. Supplement not Supplant. Federal funds shall be used to supplement, not supplant the amount of funds or services available from non-federal sources, in compliance with the requirements of federal law. ESSA funds shall not be used to provide services otherwise required by law to be made available.
3. Equitable Allocation. Federal funds shall be used in a manner to ensure equitable allocation of resources. Staff are to be assigned and curriculum materials and instructional supplies are to be distributed to the schools in such a way that equivalence of personnel and materials is ensured among the schools in compliance with the requirements of federal law.
4. Maintenance of Effort. The District shall maintain fiscal effort related to ESSA programs in compliance with the requirements of federal law.
5. Resources. The procurement of resources related to the ESSA programs, including contracts and purchase or service agreements for such program, shall be in accordance with the District’s written procedures for purchasing and contracting. Purchase orders and invoices shall indicate an appropriate record of expenditures. All equipment purchased with federal funds, including those used in nonpublic and other facilities, shall be appropriately identified, inventoried, and when no longer useful to the program, properly disposed. Resources such as staff, materials and equipment funded by Title I shall be used only for children participating in the program.
6. Maintenance of Records. Records of all federal financial and program information shall be kept for a minimum of 5 years after the start date of the project.
7. Identification of Eligible Children. The Superintendent and the designees shall implement an appropriate process to identify children eligible for services provided under federal programs.

8. Coordination of Services. Title I services shall be coordinated and integrated with the regular classroom, with other agencies providing services and with other federal, state and local programs.
9. Standards and Expectations. Students receiving services in Title I are held to the same standards and expectations as all other students.
10. Assessments. Students receiving services in Title I are assessed with the regular population without accommodations.
11. Parents Right to Know. At the beginning of each school year, if the District receives Title I funding, the District shall notify the parents of each student attending any school receiving Title I funds that the parents may request, and the District will provide the parents on request (and in a timely manner), information regarding the professional qualifications of the student's classroom teachers, including at a minimum, the following:
  - (A) Whether the student's teacher—
    - (i) has met State qualification and licensing criteria for the grade levels and subject areas in which the teacher provides instruction;
    - (ii) is teaching under emergency or other provisional status through which State qualification or licensing criteria have been waived; and
    - (iii) is teaching in the field of discipline of the certification of the teacher.
  - (B) Whether the child is provided services by paraprofessionals and, if so, their qualifications.
12. Testing Opt-Out. At the beginning of each school year, if the District receives Title I funding, the District shall notify the parents of each student attending any school receiving Title I funds that the parents may request, and the District will provide the parents on request (and in a timely manner), information regarding any State or District policy regarding student participation in any State or District assessments, including the District's policy and procedure on the parental right to opt the child out of such assessment(s). The District shall also make widely available through public means (including by posting in a clear and easily accessible manner on the District's website) information on each State or District assessment, including:
  - (A) the subject matter assessed;
  - (B) the purpose for which the assessment is designed and used;
  - (C) the source of the requirement for the assessment;
  - (D) the amount of time students will spend taking the assessment, and the schedule for the assessment; and
  - (E) the time and format for disseminating results.
13. Language Instruction Programs. At the beginning of each school year, if the District receives Title I funding, the District will implement an effective means of outreach to parents of English learners to inform the parents regarding how the parents can—
  - (A) be involved in the education of their children; and
  - (B) be active participants in assisting their children to—
    - (i) attain English proficiency;

- (ii) achieve at high levels within a well-rounded education; and
- (iii) meet the challenging State academic standards expected of all students.

The District will also inform parents of an English learner identified student of opportunities to participate in various school programs, as set forth in ESSA.

14. Other Requirements. The Superintendent shall take or cause other staff to take such action as required by law for the District to maintain compliance with ESSA and specific ESSA grant programs in which the District participates.

Legal Reference: ESSA

Date of Adoption: [Insert Date]

Personnel - All Employees

Prohibition on Aiding and Abetting Sexual Abuse

A school employee, contractor, or agent of the school district is prohibited from assisting another school employee, contractor or agent in obtaining a new job if the individual knows or has probable cause to believe, that such other employee, contractor, or agent engaged in sexual misconduct with a minor or student in violation of the law.

“Assisting” does not include the routine transmission of administrative and personnel files.

Exceptions to giving such assistance may only be made where the exception is authorized by the Every Student Succeeds Act (for example, where the matter has been investigated by law enforcement and the person has been exonerated and approved by the Superintendent or designee.)

Legal Reference: **ESSA sec. 8038, § 8546**

Date of Adoption: [Insert Date]

Personnel - All EmployeesWorkplace Privacy Policy

1. The District will abide by the Nebraska Workplace Privacy Act and will not:
  - a. Require or request that an employee or applicant provide or disclose any user name or password or any other related account information in order to gain access to the employee's or applicant's personal Internet account by way of an electronic communication device;
  - b. Require or request that an employee or applicant log into a personal Internet account by way of an electronic communication device in the presence of the District in a manner that enables the District to observe the contents of the employee's or applicant's personal Internet account or provides the District access to the employee's or applicant's personal Internet account;
  - c. Require an employee or applicant to add anyone, including the District, to the list of contacts associated with the employee's or applicant's personal Internet account or require or otherwise coerce an employee or applicant to change the settings on the employee's or applicant's personal Internet account which affects the ability of others to view the content of such account;
  - d. Take adverse action against, fail to hire, or otherwise penalize an employee or applicant for failure to provide or disclose any of the information or to take any of the actions prohibited by the Workplace Privacy Act.
  - e. Require an employee or applicant to waive or limit any protection granted under the Workplace Privacy Act as a condition of continued employment or of applying for or receiving an offer of employment.

Notwithstanding anything to the contrary, all employees must abide by the District's technology policies, procedures and guidelines, including the District's Internet Use policy and/or practice. Pursuant to the Workplace Privacy Act, the District may also:

- a. Monitor, review, access, or block electronic data stored on an electronic communication device supplied by or paid for in whole or in part by the District or stored on the District's network, to the extent permissible under applicable laws;
- b. Access information about an employee or applicant that is in the public domain or is otherwise obtained in compliance with the Workplace Privacy Act;
- c. Conduct an investigation or require an employee to cooperate in an investigation if the District has specific information about potentially wrongful activity taking place on the employee's personal Internet account, for the purpose of ensuring compliance with applicable laws, regulatory requirements, or prohibitions against work-related employee misconduct;
- d. Any other reason permitted by the Workplace Privacy Act.

Legal Reference:       Laws 2016, LB 821

Date of Adoption:     [Insert Date]

StudentsOption EnrollmentA. Process and Time Lines to Option In

For a student to attend [Name] Public Schools as an option enrollment student, the student's parent or legal guardian must submit an application to the Board of Education of the [Name] Public School District between September 1 and March 15 for enrollment during the following and subsequent school years (the "application period").

Upon receipt of an application, the Superintendent or the Superintendent's designee shall provide the resident school district with the name of the applicant on or before April 1 or, in the case of an application submitted after March 15, within sixty days after submission.

**Provisions for Waiver of Application Deadline (Choose one or modify as desired):****Option 1 (Waiver unless at capacity):**

The application deadline will be waived by the School Board for applications to option into the [Name] Public School District, provided that the application contains a release approval from the resident district and satisfies any other requirements of law. Further, the application deadline shall not be waived if the application is for enrollment in any program, class, grade level or school building or in any special education programs operated by this School District which have been determined by the School Board to be at capacity in accordance with the capacity standards (Appendix "1"), and no waiver of the deadline shall be made for such an application regardless of whether such capacity determinations are declared invalid for any reason.

**Option 2 (Limited Deadline Waiver):**

The application deadline will **not** be waived by the School Board for applications to option into the [Name] Public School District, except in the following circumstances:

1. **Siblings**: The application deadline will be waived where the application is for a student who is the sibling of a student attending [Name] Public Schools as of the time the application is filed, provided the application is filed at least 30 days prior to the semester in which first enrollment is sought. A "sibling" for this purpose means a child who resides in the same household on a permanent basis with a student who is currently attending [Name] Public Schools and who has the same natural or adoptive parent or who is a stepbrother or stepsister.
2. **Kindergarten**: The application deadline will be waived where the application is for a student who is seeking to enroll and attend the Kindergarten grade level provided the application was filed on or before June 1 prior to the first semester of the next school year.
3. **Release Approval**: For the foregoing exceptions, the application must contain a release approval from the resident district.

4. Other Conditions: The waiver of the deadline in the above circumstances does not require acceptance of the application, as such applications may be rejected for reasons other than late filing.
5. Capacity: For the foregoing exceptions, the application deadline shall not be waived if the application is for enrollment in any program, class, grade level or school building or in any special education programs operated by this School District which have been determined by the School Board to be at capacity in accordance with the capacity standards (Appendix "1"), and no waiver of the deadline shall be made for such an application regardless of whether such capacity determinations are declared invalid for any reason.
6. Capacity for Late Filed Applications: Where an application is filed for enrollment in the same school year in which enrollment is sought, the "projected enrollment" determinations made pursuant to paragraph D shall be replaced with the "actual enrollment" as of the first day of school for the year of application, as determined by the Superintendent or the Superintendent's designee, but only in the event such actual enrollment is higher than the projected enrollment. Actual enrollment shall include all students in attendance and all students registered to attend (even if not in actual attendance on the first day).

B. Rejection of Applications; Reasons

1. Capacity: An option enrollment application shall be rejected in the event the capacity of a program, class, grade level, or school building or the availability of appropriate special education programs operated by the School District would be exceeded by acceptance of the application, and an option enrollment application shall be rejected in the event the application is for enrollment in a program, class, grade level, or school building which has been declared unavailable to option students due to lack of capacity.
2. Timeliness: An option enrollment application shall be rejected in the event the application is not filed on a timely basis and the filing deadline has not been waived.
3. Previous Option Enrollment: An option enrollment application shall be rejected in the event the student has previously filed an option enrollment application for enrollment in any School District and has had such application accepted, unless a statutory exception to the "one-time" rule is applicable to the student's circumstance.
4. Other Reasons: An option enrollment application may be rejected in the event the Superintendent, the Superintendent's designee, or the School Board determines: The application is not submitted on a form prescribed by the State Department of Education, is not completely and accurately filled in, is not received within the time required by law, or any additional information requested to be supplied is not

supplied to the School District within the time lines indicated; or in the event acceptance of the application is not required by law. Matters which are legally prohibited from being considered as standards for acceptance or rejection of applications (including “previous academic achievement, athletic or extracurricular ability, disabilities, proficiency in the English language, or previous disciplinary proceedings” and further including, without limitation, race, national origin, and gender) shall not be considered as reasons for acceptance or rejection.

C. Priority of Acceptance

Priority shall be accorded in the following order: (1) first, to those applications required to be given priority by law, (2) second, to those with a sibling in attendance at [Name] Public Schools, with priority within this group being given to those who had earliest filed applications, and (3) third to those without an option student sibling in attendance at [Name] Public Schools, with priority within this group to those who had earliest filed applications.

Filing date determinations are made by the Superintendent, or the Superintendent’s designee. In the event applications within a group are received at the same or substantially the same time, priority as between such same-date applications shall be determined on the basis of random drawing.

D. Determination of Capacity

The School Board will determine and set, on an annual basis, the maximum number of option enrollment applications the School District will accept in any program, class, grade level or school building or in any special education programs operated by this School District, based upon available staff, facilities, projected enrollment of resident students, projected number of students with which this School District will contract based on existing contractual arrangements, and availability of appropriate special education programs, and may declare a program, class or school unavailable to option students due to lack of capacity. Such determinations may be made in the form of an Appendix “1” to this Policy. The determination and declaration made for any school year shall continue in effect for the next and subsequent school years unless otherwise determined and/or declared.

E. Releases for Options Out

**Provisions for Release (Choose one or modify as desired):**

Option 2 (Release unless Expulsion is Pending):

A request for release of a resident student of the [Name] Public School District who submits an enrollment option application after March 15 or any other statutory deadline will be granted unless the release shall not be granted if the administration is considering or has recommended expulsion of the student at the time the application is filed, and the administration determines it is appropriate to complete the expulsion process.

Option 2 (Release Conditions):

A request for release of a resident student of the [Name] Public School District who submits an enrollment option application after March 15 or any other statutory deadline will be granted only on the following conditions:

1. Kindergarten: A release will be granted where the application is for a student who is seeking to enroll and attend the Kindergarten grade level provided the application was filed on or before June 1 prior to the first semester of the next school year.
2. Siblings: A release will be granted where the application would allow the student to attend the same school as a sibling, provided the application is filed at least 30 days prior to the semester in which first enrollment is sought. A “sibling” for this purpose means a child who resides in the same household on a permanent basis with a student who is currently enrolled in the option district and who has the same natural or adoptive parent or who is a stepbrother or stepsister.
3. Educational Programming: A release will be granted where the needs of the student require the District to obtain additional staffing or equipment and it is in the best interests of the District and the student to enroll in the option district. The determination of whether this condition is met shall be made by the Superintendent or the Superintendent’s designee.
4. No Pending Expulsion: The deadline shall not be waived if the administration is considering or has recommended expulsion of the student at the time the application is filed, and the administration determines it is appropriate to complete the expulsion process.

The Superintendent or the Superintendent’s designee is hereby authorized to execute such releases on behalf of the School Board and the School District, subject to subsequent ratification by the School Board.

F. Notification of Acceptance or Rejection

In the case of an application to option enroll into the [Name] Public School District, the Superintendent or the Superintendent’s designee shall notify, in writing, the parent or legal guardian of the student and the resident school district whether the application is accepted or rejected on or before April 1 or, in the case of an application submitted after March 15, within sixty days after submission.

If an option enrollment application or a request for release is rejected by the [Name] Public School District, the Superintendent or the Superintendent’s designee shall provide written notification to the parent or guardian stating the reasons for the rejection and the process for appealing such rejection to the State Board of Education. Such notification shall be sent by certified mail.

G. Applications Subsequent to Relocations or Mergers

An option enrollment application does not require a release and shall be accepted or rejected within forty-five days after filing in the following circumstances:

1. the student relocated to a different resident school district after February 1, or
2. the student's option school district merged with another district effective after February 1, and
3. the application is for attendance during the immediately following and subsequent school years.

H. Status of Option Student

A student who is admitted under the enrollment option program shall be treated as a resident student, and in such regard shall be required to provide such enrollment information and documentation as is required for enrollment of other students (e.g., certified birth certificate and evidence of physical examination, visual evaluation and immunization), shall be required to be enrolled on a full-time basis, and shall be required to adhere to student conduct rules. The building assignment for an option student, as well as classroom and grade level assignments, shall be determined by the administration.

An option student shall not be entitled to transportation except as required by law. Transportation or transportation reimbursement will be provided in the following circumstances:

1. The [Name] Public School District may, upon mutual agreement with the parent or legal guardian of an option student, provide transportation to the option student on the same basis as provided for resident students. The school district may charge the parents of each option student transported a fee sufficient to recover the additional costs of such transportation.
2. Option students who qualify for free lunches are eligible for either free transportation or transportation reimbursement from the option school district.
3. For option students receiving special education services, the transportation services required in the student's Individualized Education Plan shall be provided by the resident school district.

I. Information Regarding Schools, Programs, Policies and Procedures.

As part of the option enrollment program, the administration shall make information about the [Name] Public Schools and its school, programs, policies and procedures available to all interested persons and shall have a copy of the option enrollment policy and regulations available at each school building.

Legal Reference: Neb. Rev. Stat. §§ 79-232 to 79-246

Date of Adoption: [Insert Date]

StudentsDrug and Substance Use and Prevention**Drug-Free Schools**

The District shall implement regulations and practices which will ensure compliance with the Drug-Free Schools and Communities Act and all regulations and rules promulgated pursuant thereto. The District's safe and drug-free schools program is established in accordance with principles of effectiveness as required by law to respond to such harmful effects.

**Education and Prevention**

The District promotes comprehensive, age appropriate, developmentally based drug and alcohol education and prevention programs, which will include in the curriculum the teaching of both proper and incorrect use of drugs and alcohol for all students in all grades of this School District. Further, the District will have proper in-service orientation and training for all employed staff.

**Standards of Conduct; Notice to Students and Parents**

Students are to be provided a copy of the standards of conduct for student behavior in the District which prohibit the unlawful possession, use, or distribution of illicit drugs and alcohol on school premises or as a part of any of the school's activities. It shall be the further policy of the District to keep a file showing receipt of standards of conduct and a statement of disciplinary sanctions that may be taken for violations of such standards of conduct. The receipt shall be signed by both student and parent or guardian and returned to the respective Principal. It shall contain in prominent letters the following language:

"RECEIPT SHALL SERVE TO DEMONSTRATE THAT YOU AS PARENT OR GUARDIAN OF A STUDENT ATTENDING [NAME] PUBLIC SCHOOLS HAVE RECEIVED NOTICE OF THE STANDARDS OF CONDUCT OF THIS DISTRICT EXPECTED OF STUDENTS CONCERNING THE ABSOLUTE PROHIBITION AGAINST THE UNLAWFUL POSSESSION, USE, OR DISTRIBUTION OF ILLICIT DRUGS AND ALCOHOL ON SCHOOL PREMISES OR AS A PART OF ANY OF THE SCHOOL'S ACTIVITIES AS DESCRIBED IN BOARD POLICY OR ADMINISTRATIVE REGULATION. THIS NOTICE IS BEING PROVIDED TO YOU PURSUANT TO P.L. 101-226 AND 34 C.F.R. PART 86, BOTH FEDERAL LEGAL REQUIREMENTS FOR THE DISTRICT TO OBTAIN ANY FEDERAL FINANCIAL ASSISTANCE. YOUR SIGNATURE ON THIS RECEIPT ACKNOWLEDGES THAT YOU AND YOUR CHILD OR CHILDREN WHO ARE STUDENTS ATTENDING THIS DISTRICT FULLY UNDERSTAND THE DISTRICT'S POSITION ABSOLUTELY PROHIBITING THE UNLAWFUL POSSESSION, USE, OR DISTRIBUTION OF ILLICIT DRUGS AND ALCOHOL ON SCHOOL PREMISES OR AS A PART OF THE SCHOOL'S ACTIVITIES AS HEREIN ABOVE DESCRIBED AND THAT COMPLIANCE WITH THESE STANDARDS IS MANDATORY. ANY NON-COMPLIANCE WITH THESE STANDARDS CAN AND WILL RESULT IN PUNITIVE MEASURES BEING

TAKEN AGAINST ANY STUDENT FAILING TO COMPLY WITH THESE STANDARDS."

**Drug and Alcohol Education and Prevention Program of the District Pursuant to the Safe and Drug-Free Schools and Communities Laws and Regulations**

Students are to be provided an age appropriate, developmentally based drug and alcohol education and prevention program. The program educates on the adverse effects of the use of illicit drugs and alcohol, with the primary objective being the prevention of illicit drug and alcohol use by students.

**Drug and Alcohol Counseling, Rehabilitation and Re-entry Programs**

Students are to be provided information concerning available drug and alcohol counseling, rehabilitation, and re-entry programs within sixty miles of the administrative offices of the District or, where no such services are found, within the State of Nebraska. Information concerning such resources shall be presented to all of the students of the District upon request by the counselor.

In the event of disciplinary proceedings against any student for any District policy pertaining to the prohibition against the unlawful possession, use, or distribution of illicit drugs and alcohol, appropriate school personnel shall confer with any such student and his or her parents or guardian concerning available drug and alcohol counseling, rehabilitation, and re-entry programs that appropriate school personnel shall consider to be of benefit to any such student and his or her parent or parents or guardian.

**Safe and Drug-Free Schools-- Parental Notice of Right to Withdraw**

Parents will be notified that, if upon receipt of information regarding the content of safe and drug free school programs and activities other than classroom instruction a parent objects to the participation of their child in such programs and activities, the parent may notify the School District of such objection in writing. Upon the receipt of such notice the student will be withdrawn from the program or activity to which parental objection has been made.

**Standards of Student Conduct Pertaining to the Possession, Use, or Distribution of Illicit Drugs, Alcohol or Tobacco.**

These standards are in addition to standards of student conduct elsewhere adopted by board policy or administrative regulation. The District's standards prohibit the possession, use, or distribution of illicit drugs, alcohol or tobacco on school premises, in school vehicles, or as a part of any of the school's activities on or off school premises. Conduct prohibited at places and activities as hereinabove described shall include, but not be limited to, the following:

1. Possession, use distribution or being under the influence of any controlled substance, including but not limited to marijuana, any narcotic drug, any hallucinogen, any stimulant, or any depressant.
2. Possession of any prescription drug in an unlawful fashion.
3. Possession, use, distribution or being under the influence of alcohol.
4. Possession, use, distribution, or being under the influence of any abusable glue or aerosol paint or any other chemical substance for inhalation, including but not limited

- to lighter fluid, whiteout, and reproduction fluid, when such activity constitutes a substantial interference with school purposes.
5. Possession, use, or distribution of any look-alike drug or look-alike controlled substance when such activity constitutes a substantial interference with school purposes.
  6. Possession, use or distribution of any tobacco product.

### **Disciplinary Sanctions**

Violation of any of the above prohibited acts will result in disciplinary sanction being taken within the bounds of applicable law, up to and including short term suspension, long term suspension, expulsion, and referral to appropriate authorities for criminal prosecution. In particular, students should be aware that:

1. Violation of these standards may result in suspension or expulsion.
2. Prohibited substances will be confiscated and turned over to law enforcement authorities.
3. The student may be referred for counseling or treatment.
4. Parents or legal guardian will be notified.
5. Law enforcement will be notified.
6. If it appears there is imminent danger to the student, other students, school personnel, or students involved, emergency medical services will be contacted.

### **Intervention**

The [Name] Public School District does not have the authority or responsibility to make medical or health determinations regarding chemical dependency. However, when observed behavior indicates that a problem exists which may affect the student's ability to learn or function in the educational climate or activity, the school then has the right and responsibility to refer the student for a formal chemical dependency diagnosis based on behavior observed by school staff. The school will issue a statement to all students and employed staff that the use of illicit drugs and the unlawful possession and use of alcohol is wrong and harmful. The school shall make available to students and employed staff information about any drug and alcohol counseling, and rehabilitation and re-entry programs, which are available to students.

### **Administration**

The administration is authorized to adopt such administrative rules, regulations or practices necessary to properly implement this policy. Such regulations, rules or practices may vary the procedures set forth herein to the extent necessary to fit the circumstances of an individual situation. Such rules, regulations and practices may include administrative forms, such as checklists to be used by staff to record observed behavior and to determine the proper plan of action.

Date of Adoption: [Insert Date]

StudentsAcademic Progress

The Superintendent will be responsible for implementing a uniform system for appraising and reporting the development of students' academic and behavioral skills.

Communicating student progress to parents shall be the responsibility of the building administrator and the classroom teacher. Written reports of student progress will be made available to parents at the conclusion of each quarter. It is recommended that two parent-teacher conferences or acceptable substitutes be held in both the elementary and junior-senior high school each year. Additional reporting of student progress is encouraged whenever progress or lack of progress is of an unusual nature.

Date of Adoption: [Insert Date]

StudentsHomeless Students

This School District will comply with the federal and state law related to homeless students.

A “homeless child” for purposes of this Policy is a child who lacks a fixed, regular, and adequate nighttime residence, as defined by applicable federal and state law related to homeless students. An “unaccompanied youth” is a child who is not in the physical custody of a parent or guardian.

1. Homeless Coordinator: The District’s designated Homeless Coordinator is the Superintendent. The Homeless Coordinator may delegate the specified duties as the Homeless Coordinator determines to be appropriate. The Homeless Coordinator shall serve as the school liaison for homeless children and youth.
  - a. Responsibilities. The responsibilities of the Homeless Coordinator are to assist with identification, enrollment, and placement of homeless children and to provide staff development activities to all school personnel regarding the educational rights and needs of homeless children and youth. The Homeless Coordinator shall ensure that:
    - i. homeless children are identified by school personnel;
    - ii. homeless children enroll in, and have a full and equal opportunity to succeed in school;
    - iii. homeless children and their families receive educational service for which they are eligible and referrals to health, dental, and mental health services and other appropriate services;
    - iv. the parents or guardians of homeless children are informed of the educational and related opportunities available to their children and are provided with meaningful opportunities to participate in the education of their children;
    - v. public notice of the educational rights of homeless children is disseminated where such children receive services under the federal homeless children laws, such as schools, family shelters, and soup kitchens;
    - vi. enrollment disputes are mediated in accordance with law; and
    - vii. the parents or guardians of homeless children, and any unaccompanied youth, are fully informed of transportation services available under law.
  - b. Coordination. The Homeless Coordinator shall coordinate with State coordinators and community and school personnel responsible for the provisions of education and related services to homeless children. Coordination activities with area shelters and other homeless service providers are to be established by the Homeless Coordinator.
  - c. Financial. The Homeless Coordinator shall ensure that financial records are maintained to show expenditures are for authorized activities. Title I, Part A

homeless set-aside funds are also to be used for services for homeless children. Materials and equipment purchased with grant funds are properly identified and inventoried.

- d. Program Activities. The Homeless Coordinator shall design program activities to meet the greatest need as determined by the District and homeless service providers.
  - e. Documentation. The Homeless Coordinator shall document the number of homeless children and youth receiving services.
  - f. Student Records. The Homeless Coordinator shall ensure that any record ordinarily kept related to students, including immunization or medical records, academic records, birth certificates, guardianship records, and evaluations for special services or programs, are to be maintained so that the records of a homeless child are available, in a timely fashion, when the child enters a new school or school district and in a manner consistent with the Federal Education Rights and Privacy Act.
  - g. Notice. The District shall annually inform school personnel, service providers, advocates working with homeless families, parents and guardians of homeless children and youths, and homeless children and youths of the duties of the Homeless Coordinator, and shall annually provide to NDE the identity of the District's Homeless Coordinator.
2. Enrollment and Placement of Homeless Children: The enrollment and placement of homeless children shall be in compliance with federal and state law.
- a. Enrollment. A homeless child shall be immediately enrolled even if the child is unable to produce records normally required for enrollment. Lack of previous school records, immunization and medical records, birth certificate, or other documentation from the previous school will not delay the enrollment of a homeless child or youth. Guardianship issues, uniform or dress code requirements, and residency requirements will not be obstacles to delay or deny enrollment. The District may nonetheless require the parent or guardian of the homeless child to submit contact information.
  - b. Obtaining Records. The District shall immediately contact the school last attended by the homeless child to obtain relevant academic and other records. If the homeless child needs to obtain immunizations or medical records, the District shall immediately refer the parent or guardian of the homeless child to the Homeless Coordinator, who shall assist in obtaining necessary immunizations or medical records.
  - c. Placement. Placement decisions for a homeless child shall be made according to the District's determination of the child's best interests.

- i. The placement shall be at either:
    1. The child's "school of origin," which is the school that the child attended when permanently housed or the school in which the child was last enrolled; or
    2. The school of the attendance area in which the child is actually living.
  - ii. If placed in the school of origin, the placement shall continue for the duration of the child's homelessness. If the child becomes permanently housed (no longer homeless) during the school year, the placement in the school of origin will be continued for the remainder of that school year.
  - iii. To the extent feasible the placement shall be in the school of origin except when such is contrary to the wishes of the homeless child's parent or legal guardian. If the placement is not in the school of origin or a school requested by the homeless child's parent or legal guardian, the District shall provide a written explanation of the placement decision and a statement of appeal rights to the parent or guardian.
  - iv. If the homeless child is an unaccompanied youth, the Homeless Coordinator shall assist in the placement decision, consider the views of the unaccompanied youth, and provide the unaccompanied youth with notice of the right to appeal.
  - v. The grade placement for the homeless child will be the appropriate grade level as determined by the building principal or designee using the same procedures that are used for placing non-homeless children attending that school.
3. Educational Services and Stigmatization or Segregation: It is the District's policy that homeless children not be stigmatized or segregated on the basis of their status as homeless. Homeless children will be provided the same free, appropriate public education as other students. Homeless students will be provided services comparable to services offered to other students in the school in which the homeless child has been placed, including the following: transportation services, educational services for which the student meets the eligibility criteria, such as services provided under Title I, educational programs for children with disabilities, and educational programs for students with limited English proficiency, programs in vocational and technical education, programs for gifted and talented students, and school nutrition programs.
  4. Transportation: Transportation will be provided to homeless students to the extent required by law.
    - a. Comparable Service. Transportation will be provided to a homeless student comparable to that provided to students who are not homeless.
    - b. School of Origin. When the homeless student attends the school of origin, transportation will be provided to and from the school of origin upon request of the parent or guardian of the homeless child, or upon request of the Homeless

Coordinator in the case of an unaccompanied youth. If the homeless child relocates out of the District but continues to be enrolled in this School District based on it being the school of origin, this School District will negotiate with the school district in which the child is residing to develop a method to apportion the responsibility and costs for providing the child with transportation to and from the school of origin. If agreement is not reached, the responsibility and cost for transportation shall be shared equally.

- c. Eliminate Barriers. Transportation will be provided when necessary to eliminate barriers to school enrollment and the retention of students experiencing homelessness.
5. Dispute Resolution Process. The process to resolve disputes concerning the enrollment or placement of a child or youth experiencing homelessness is as follows:
- a. The child and the parent, guardian or other person having legal or actual charge or control of the child shall be referred to the Homeless Coordinator. The Homeless Coordinator shall carry out the dispute resolution process as expeditiously as possible after receiving notice of the dispute within not less than thirty (30) calendar days. The dispute resolution process is as follows:
    - i. The child or parent/guardian will notify the Homeless Coordinator. The District's Dispute Resolution Form shall be used if such is available.
    - ii. When it is determined that additional information would be helpful, the Homeless Coordinator will schedule a meeting within 10 days, or such time as practicable, at which the child and parent/guardian will be given the opportunity to provide information in support of their position.
    - iii. The Homeless Coordinator will contact school officials and others as determined appropriate to obtain information to corroborate the information provided in support of the positions of the child and parent/guardian and the District.
    - iv. The Homeless Coordinator will provide a written response and explanation of a decision regarding the dispute within 30 calendar days after receiving the dispute statement.
    - v. The written response and explanation of the decision will include a notice of the right to appeal using the appeal process provided for in the Nebraska Department of Education Rule 19.
  - b. . In the case of an unaccompanied youth, the District liaison will ensure that the youth is enrolled immediately in the school in which enrollment is sought pending resolution of the dispute;
  - c. The District will ensure the immediate enrollment of the child in the school in which enrollment is sought pending resolution of the dispute; and
  - d. The District's written response will include a notice of the right to appeal as provided in Nebraska Department of Education Rule 19, Section 005.03.

6. Right to Appeal.

- a. Any parent, guardian or other person having legal or actual charge or control of a homeless child or youth or an unaccompanied youth that is dissatisfied with the decision of the District after the dispute resolution process may file a written appeal with the Nebraska Commissioner of Education within thirty (30) calendar days of receipt of the decision. Refer to NDE, Rule 19, Section 005.03 for further details.
- b. A party may appeal the decision of the Commissioner or designee by filing a Petition with the State Board of Education within thirty (30) calendar days of the receipt of the decision. Refer to NDE, Rule 19, Section 005.03C for further details.

Legal Reference:      Neb. Rev. Stat. § 79-215  
                             Nebraska Department of Education Rule 19  
                             McKinney-Vento Homeless Assistance Act, 42 USC §§11431, et seq.

Date of Adoption:    [Insert Date]

Homeless Education Program

HOMELESS STUDENT ENROLLMENT INFORMATION & PLACEMENT REQUEST

Child's Name: \_\_\_\_\_ Birth Date: \_\_\_\_\_ Grade \_\_\_\_\_
(Last Name) (First Name) (M.I.)

Parent/Guardian Name \_\_\_\_\_ Unaccompanied Youth \_\_\_\_\_
(Last Name) (First Name) (M.I.) ("Yes" or "No")

Current Address \_\_\_\_\_

Telephone Number: \_\_\_\_\_
(If phone # not available, phone number of someone who can be contacted and their relationship, if any).

Information provided on this form is confidential.

1. Homeless Status

a. Do you live in any of these following situations?

- \_\_\_\_\_ sharing the housing of other persons due to loss of housing, economic hardship, or a similar reason (example: evicted from home, cannot afford housing, etc.)
\_\_\_\_\_ in a motel, hotel, campground or similar setting due to lack of alternative adequate accommodations
\_\_\_\_\_ in emergency or transitional shelters such as domestic violence or homeless shelters or transitional housing shelter or agency
\_\_\_\_\_ have a primary nighttime residence that is a place not designed for or ordinarily used as a regular sleeping accommodation for humans
\_\_\_\_\_ in cars, parks, public spaces, abandoned buildings, substandard housing, bus or train stations, or similar settings
\_\_\_\_\_ None of the above.

b. How long do you anticipate living in current location? \_\_\_\_\_

2. School Most Recently Attended

School: \_\_\_\_\_
(School Name) (City) (State)

Dates of Attendance: \_\_\_\_\_ to \_\_\_\_\_

Grade level when last attended: \_\_\_\_\_

3. Eligible for any of these educational and school related activities and services?

□ Special Education (IDEA) If yes, please identify disability and special education services previously provided : \_\_\_\_\_

- English Language Learners (ELL)  Gifted  Vocational Education
- Other \_\_\_\_\_

4. Possible Barriers to Education

- No Birth Certificate  No immunizations or other medical records
- No School Records  Transportation  School Selection
- Other issues/barriers \_\_\_\_\_

5. Requested Services and Activities to be Provided by Homeless Student Program

- Obtaining or transferring records necessary for enrollment
- Emergency assistance related to school attendance
- Expedited evaluations
- Transportation  Clothing to meet a school requirement  School supplies
- Early childhood program  Tutoring or other instructional support
- Before/after-school, mentoring, summer programs
- Referrals for medical, dental, or other health services
- Referral to other programs/services
- Assistance with participation in school programs
- Parent education related to rights/resources
- Coordination between schools and agencies
- Counseling  Addressing needs related to domestic violence
- Staff professional development/awareness
- Other \_\_\_\_\_

6. Placement

a. School placement requested by parent/guardian or unaccompanied youth:

\_\_\_\_\_

b. Reason(s) for Request: \_\_\_\_\_

\_\_\_\_\_

c. Name of "School of Origin" \_\_\_\_\_

(School of Origin means the school that the child attended when permanently housed or the school in which the child was last enrolled).

Enrollment Date \_\_\_\_\_

Has student been withdrawn? \_\_\_\_\_

If so, what was the withdraw date? \_\_\_\_\_

d. Distance from:

i. Residence to the school of origin (miles): \_\_\_\_\_

ii. Residence to the school requested (if not school of origin): \_\_\_\_\_

\_\_\_\_\_  
Parent or Guardian or Unaccompanied Youth's signature

\_\_\_\_\_  
Date

Children living in homeless situations have certain rights under the McKinney-Vento Homeless Assistance Act. Please contact the Homeless Coordinator with any questions.

**WRITTEN NOTIFICATION OF ENROLLMENT/PLACEMENT DECISION FOR HOMELESS STUDENT**

Child's Name: \_\_\_\_\_

In compliance with the McKinney-Vento Homeless Assistance Act, the following written notification is provided to:

Parent/Guardian \_\_\_\_\_ Unaccompanied Youth \_\_\_\_\_  
( Name) (Name)

After reviewing your request to enroll the child, the determinations are as follows:

**Homeless student program eligibility:**

- \_\_\_\_\_ Child does not qualify under the homeless student program.
- \_\_\_\_\_ Child qualifies under the homeless student program. This determination was based upon: \_\_\_\_\_

**Placement** (if enrolled under the homeless student program) was made based on best interest of the student. The placement will be at: \_\_\_\_\_  
( Name)

Explanation for this determination (if not school of origin or the choice of parent/guardian or unaccompanied youth, give detail): \_\_\_\_\_  
\_\_\_\_\_  
\_\_\_\_\_

If you are not satisfied with the determinations, you have the right to use the dispute resolution process. Contact the Homeless Coordinator and complete a Dispute Resolution Form.

**Notices:**

- The student has the right to be immediately admitted in the school in which enrollment is sought pending resolution of the dispute.
- You may contact the state coordinator:  
Education Specialist & Homeless Education / NCLB Programs  
Nebraska Department of Education  
<http://www.education.ne.gov/federalprograms/Title%20X.html>  
Telephone: (402) 471-1419 Facsimile: (402) 742-2371
- You may seek the assistance of advocates or attorneys.

\_\_\_\_\_  
Administrator

\_\_\_\_\_  
Date

Written Notification Form was given to parent/guardian or unaccompanied youth on \_\_\_\_\_ (Date).

**Homeless Education Program  
DISPUTE RESOLUTION FORM**

This form should be completed when a dispute arises over school enrollment/placement.

Child's Name: \_\_\_\_\_

Person completing form: \_\_\_\_\_  
(Name) (Relation to Student)

I may be contacted at (address/phone/e-mail): \_\_\_\_\_

I wish to dispute the following decision: \_\_\_\_\_

The decision I am disputing was wrong because (give detailed information in support of your position and use an attachment if necessary): \_\_\_\_\_

Persons who have information to support my position (include contact information): \_\_\_\_\_

I request that the following action be taken on this dispute: \_\_\_\_\_

Parent or Guardian or Unaccompanied Youth's signature \_\_\_\_\_

Date \_\_\_\_\_

**-----For School Use-----**

Date received by Homeless Coordinator \_\_\_\_\_

**-----Determination of Homeless Coordinator-----**

In compliance with the McKinney-Vento Homeless Assistance Act, the following written notification is provided to:

Parent/Guardian \_\_\_\_\_ Unaccompanied Youth \_\_\_\_\_  
(Name) (Name)

After reviewing the information relevant to your dispute my determination is as follows:

Explanation for this determination: \_\_\_\_\_

Notice of Right to Appeal: If you are not satisfied with the determination on this dispute, you have the right to appeal as provided for in the Nebraska Department of Education Rule 19. The appeal is to be filed with the Commissioner of Education within 30 calendar days of receipt of this decision. For information about an appeal you may contact the state coordinator:

Education Specialist & Homeless Education / NCLB Programs

Nebraska Department of Education

<http://www.education.ne.gov/federalprograms/Title%20X.html>

Telephone: (402) 471-1419 Facsimile: (402) 471-0117

\_\_\_\_\_  
Administrator

\_\_\_\_\_  
Date

The Determination of the Homeless Coordinator on this dispute was given to parent/guardian or unaccompanied youth on \_\_\_\_\_ (Date).

StudentsStudent Privacy Protection Policy

It is the policy of [Name] Public Schools to develop and implement policies which protect the privacy of students in accordance with applicable laws. The District=s policies in this regard include the following:

- A. Right of Parents to Inspect Surveys Funded or Administered by the United States Department of Education or Third Parties  
Parents shall have the right to inspect, upon the parent=s request, a survey created by and administered by either the United States Department of Education or a third party (a group or person other than the District) before the survey is administered or distributed by the school to the parent=s child.
- B. Protection of Student Privacy in Regard to Surveys of Matters Deemed to be Sensitive  
The District will require, for any survey of students which contain one or more matters deemed to be sensitive (see section headed Definition of Surveys of Matters Deemed to be Sensitive), that suitable arrangements be made to protect student privacy (that is, the name or other identifying information about a particular student). For such surveys, the District will also follow the procedures set forth in the section entitled: Notification of and Right to Opt-Out of Specific Events.
- C. Right of Parents to Inspect Instructional Materials  
Parents shall have the right to inspect, upon reasonable request, any instructional material used as part of the educational curriculum for their child. Reasonable requests for inspection of instructional materials shall be granted within a reasonable period of time after the request is received. Parents shall not have the right to access academic tests or academic assessments, as such are not within the meaning of the term instructional materials for purposes of this policy.

The procedures for making and granting a request to inspect instructional materials are as follows: the parent shall make the request, with reasonable specificity, directly to the building principal. The building principal, within five school days, shall consult with the teacher or other educator responsible for the curriculum materials. In the event the request can be accommodated, the building principal shall make the materials available for inspection or review by the parent, at such reasonable times and place as will not interfere with the educator=s intended use of the materials. In the event there is a question as to the nature of the curriculum materials requested or as to whether the materials are required to be provided, the building principal shall notify the parent of such concern, and assist the parent with forming a request which can reasonably be accommodated. If the parent does not formulate such a request, and continues to desire certain curriculum materials, the parent shall be asked to make their request to the Superintendent.

D. Rights of Parents to be Notified of and to Opt-Out of Certain Physical Examinations or Screenings

The general policy and practice of the District is to not administer physical examinations or screenings of students which require advance notice or parent opt-out rights under the applicable federal laws, for the reason that the physical examinations or screenings to be conducted by the District will usually fit into one of the following exceptions: (1) hearing, vision, or scoliosis screenings; (2) physical examinations or screenings that are permitted or required by an applicable State law; and (3) surveys administered to students in accordance with the Individuals with Disabilities Education Act. For physical examinations or screenings which do not fit into the applicable exceptions, the District will follow the procedures set forth in the section entitled: Notification of and Right to Opt-Out of Specific Events.

E. Protection of Student Privacy in Regard to Personal Information Collected from Students

The general policy and practice of the District is to not engage in the collection, disclosure, or use of personal information collected from students for the purpose of marketing or for selling that information. The District will make reasonable arrangements to protect student privacy to the extent possible in the event of any such collection, disclosure, or use of personal information.

Personal information for purposes of this policy means individually identifiable information about a student including: (1) a student or parent's first and last name, (2) home address, (3) telephone number, and (4) social security number. The term personal information, for purposes of this policy, does not include information collected from students for the exclusive purpose of developing, evaluating, or providing educational products or services for, or to, students or educational institutions. This exception includes the following examples: (i) college or postsecondary education recruitment, or military recruitment; (ii) book clubs, magazines, and programs providing access to low-cost literary products; (iii) curriculum and instructional materials used by elementary schools and secondary schools; (iv) tests and assessments used by elementary schools and secondary schools to provide cognitive, evaluative, diagnostic, clinical, aptitude, or achievement information about student, or to generate other statistically useful data for the purpose of securing such tests and assessments, and the subsequent analysis and public release of the aggregate data from such tests and assessments; (v) the sale by student of products or services to raise funds for school-related or education-related activities; (vi) student recognition programs.

F. Parent Access to Instruments used in the Collection of Personal Information

While the general practice of the District is to not engage in the collection, disclosure, or use of personal information collected from students for the purpose of marketing or for selling that information, parents shall have the right to inspect, upon reasonable request, any instrument which may be administered or distributed to a

student for such purposes. Reasonable requests for inspection shall be granted within a reasonable period of time after the request is received.

The procedures for making and granting such a request are as follows: the parent shall make the request, with reasonable specificity, directly to the building principal and shall identify the specific act and the school staff member or program responsible for the collection, disclosure, or use of personal information from students for the purpose of marketing that information. The building principal, within five school days, shall consult with the school staff member or person responsible for the program which has been reported by the parent to be responsible for the collection, disclosure, or use of personal information from students. In the event such collection, disclosure, or use of personal information is occurring or there is a plan for such to occur, the building principal shall consult with the Superintendent for determination of whether the action shall be allowed to continue. If not, the instrument for the collection of personal information shall not be given to any students. If it is to be allowed, such instrument shall be provided to the requesting parent as soon as such instrument can be reasonably obtained.

#### Annual Parental Notification of Student Privacy Protection Policy

The District shall provide parents with reasonable notice of the adoption or continued use of this policy and other policies related to the student privacy. Such notice shall be given to parents of students enrolled in the District at least annually, at the beginning of the school year, and within a reasonable period of time after any substantive change in such policies.

#### Notification to Parents of Dates of and Right to Opt-Out of Specific Events

The District shall directly notify the parents of the affected children, at least annually at the beginning of the school year, of the specific or approximate dates during the school year when any of the following activities are scheduled, or are expected to be scheduled:

1. The collection, disclosure, or use of personal information collected from students for the purpose of marketing or for selling that information. (Note: the general practice of the District is to not engage in the collection, disclosure, or use of personal information collected from students for the purpose of marketing or for selling that information);
2. Surveys of students involving one or more matters deemed to be sensitive in accordance with the law and this policy; and
3. Any nonemergency, invasive physical examination or screening that is required as a condition of attendance; administered by the school and scheduled by the school in advance; and not necessary to protect the immediate health and safety of the student or of other students. (Note: the general practice of the District is to not engage in physical examinations or screenings which require advance notice, for the reason that the physical examinations or screenings to be conducted by the District will usually fit into one of the following exceptions to the advance notice requirement and parent

opt-out right: (1) hearing, vision, or scoliosis screenings; (2) physical examinations or screenings that are permitted or required by an applicable State law, and (3) surveys administered to students in accordance with the Individuals with Disabilities Education Act).

Parents shall be offered an opportunity in advance to opt their child out of participation in any of the above listed activities. In the case of a student of an appropriate age (that is, a student who has reached the age of 18, or a legally emancipated student), the notice and opt-out right shall belong to the student.

#### Definition of Surveys of Matters Deemed to be Sensitive

Any survey containing one or more of the following matters shall be deemed to be Asensitive@ for purposes of this policy:

1. political affiliations or beliefs of the student or the student=s parent;
2. mental or psychological problems of the student or the student=s parent;
3. sex behavior or attitudes;
4. illegal, anti-social, self-incriminating or demeaning behavior;
5. critical appraisals of other individuals with whom the student has close family relationships;
6. legally recognized privileged or analogous relationships, such as those of lawyers, physicians, and ministers; or
7. Religious practices, affiliations, or beliefs of the students or the student=s parent;
8. income (other than that required by law to determine eligibility for participation in a program or for receiving financial assistance under such program).

#### Mental Health Assessment or Service

The District shall obtain informed consent from the parent of each child who is under 18 years of age to participate in any mental-health assessment or service that is funded under the Every Student Succeeds Act (“ESSA”). Before obtaining the consent, the District shall provide the parent written notice describing in detail such mental health assessment or service, including the purpose for such assessment or service, the provider of such assessment or service, when such assessment or service will begin, and how long such assessment or service may last.

Legal Authorities: Every Student Succeeds Act  
 Protection of Pupil Privacy Amendment, 20 U.S.C. Sec. 1232h and 34 CFR Part 98;  
 Family Educational Rights and Privacy Act, 20 U.S.C. Sec.1232g;  
 Neb. Rev. Stat. Sec. 79-530 to 79-533

Date of Adoption: [Insert Date]

Instruction

The Program of Instruction

The minimum program of instruction in the schools shall be that prescribed by the statutes. The statutory curriculum may be augmented and extended to provide for the educational needs of individual pupils and differing areas in the School District.

The District shall educate staff and students about the harms of copyright piracy.

Legal Reference: Rule 10; ESSA

Date of Adoption: [Insert Date]

InstructionAssessments—Academic Content Standards

The Board of Education adopts the academic content standards of the State Board of Education (“State Board”). The adoption of the academic content standards includes the:

- Language Arts standards that were adopted by the State Board in September, 2014;
- Mathematics standards that were approved by the State Board in September, 2015;
- Science standards that were adopted by the State Board in November, 2010; and
- Social Studies standards that were adopted by the State Board in December, 2012.

Unless other action is taken, the Board of Education adopts the standards of the State Board as such standards are subsequently adopted or amended by the State Board.

The administration shall be responsible for implementing assessments on the state standards in accordance with the procedures established by the State Board and the Department of Education, including conducting assessments in the same subject areas and the same grade levels as established in the state standards, and the reporting of scores and sub-scores.

This policy does not supersede the existing standards adopted by the Board of Education except as set forth herein.

Legal Reference: Neb. Rev. Stat. §§ 79-760 to 79-760.05

Date of Adoption: [Insert Date]

InstructionInitiations, Hazing, Secret Clubs and Outside Organizations

Initiations. Initiations by classes, clubs or athletic teams are prohibited except with the approval of the administration. Any student who engages in or encourages initiations that have not been approved by the administration is subject to disciplinary action, up to and including denial of any or all school privileges and expulsion.

The administration may only give consent to initiation activities that are consistent with student conduct expectations and that do not present a risk of physical or mental injury or belittlement.

Hazing. Hazing by classes, clubs, athletic teams or other student organizations are prohibited. Hazing means any activity by which a person intentionally or recklessly endangers the physical or mental health or safety of an individual for the purpose of initiation into, admission into, affiliation with, or continued membership with any school organization. Such prohibited hazing activity includes whipping, beating, branding, an act of sexual penetration, an exposure of the genitals of the body done with intent to affront or alarm any person, a lewd fondling or caressing of the body of another person, forced and prolonged calisthenics, prolonged exposure to the elements, forced consumption of any food, liquor, beverage, drug, or harmful substance not generally intended for human consumption, prolonged sleep deprivation, sexual conduct, nudity, or any brutal treatment or the performance of any act which endangers the physical or mental health or safety of any person or the coercing of any such activity. Hazing is prohibited even though the person who has been the subject of the hazing consents to the activity. Any student who engages in or encourages hazing is subject to disciplinary action, up to and including denial of any or all school privileges and expulsion.

Secret Organizations. It is unlawful for students to participate in or be members of any secret fraternity or secret organization that is in any degree a school organization. Any student who violates this restriction is subject to disciplinary action, up to and including denial of any or all school privileges and expulsion.

Outside Organizations. It is unlawful for any person, whether a student of the District or not, to enter upon the school grounds or any school building for the purpose of rushing or soliciting, while there, any student to join any fraternity, society, or association organized outside of the schools. Any person who violates this restriction is subject to criminal prosecution and removal and exclusion from school grounds.

Legal Reference:      Neb. Rev. Stat. §§ 79-2,101 to 79-2,103  
                                 Student Discipline Act, Neb. Rev. Stat. §§ 79-254 to 79-296  
                                 Reference Neb. Rev. Stat. §§ 28-311.06 to 28-311.07

Date of Adoption:    [Insert Date]

Instruction

Activities

Return to Learn From Cancer

The Superintendent or designee shall make available training on how to recognize that students who have been treated for pediatric cancer and returned to school may need informal or formal accommodations, modifications of curriculum, and monitoring by medical or academic staff.

A 504 team meeting will be held, as appropriate, to develop individual return to learn accommodations and modifications.

Legal Reference: Neb. Rev. Stat. §§ 79-2,148

Date of Adoption: [Insert Date]

InstructionTitle I Parental and Family Involvement Policy

This Parental and Family Involvement Policy is established in compliance with Title I. [Name] Public Schools has a parental and family involvement policy applicable to parents and family members of all children. The parental and family involvement policy applicable to parents and family members of all children is not replaced by this Title I Parental and Family Involvement Policy and shall continue to be applicable to all parents and family members, including parents and family members participating in Title I programs.

It is the policy of [Name] Public Schools to implement programs, activities, and procedures for the involvement of parents and family members in Title I programs consistent with the Title I laws. Such programs, activities, and procedures shall be planned and implemented with meaningful consultation with parents and family members of participating children.

Expectations for Parental Involvement

It is the expectation of [Name] Public Schools that parents and family members of participating children will have opportunities available for parental and family involvement in the programs, activities, and procedures of the District's Title I program. The term "parental and family involvement" means the participation of parents and family in regular, two-way, and meaningful communication involving student academic learning and other school activities, including ensuring—(A) that parents and family members play an integral role in assisting their child's learning; (B) that parents and family members are encouraged to be actively involved in their child's education at school; (C) that parents and family members are full partners in their child's education and are included, as appropriate, in decision making and on advisory committees to assist in the education of their child; and (D) the carrying out of other activities, such as those described in this parental and family involvement policy. The District intends to meet this expectation through the following activities:

- A. Involving parents and family members in the joint development of the District's Title I plan and the processes of school review and school improvement.
- B. Providing coordination, technical assistance, and other support necessary to assist participating schools in planning and implementing effective parent and family involvement activities to improve student academic achievement and school performance.
- C. Building the schools', parents' and family's capacity for strong parental and family involvement.
- D. Coordinating and integrating parental and family involvement strategies under Title I with parental and family involvement strategies under other programs.
- E. Conducting, with the involvement of parents and family members, an annual evaluation of the content and effectiveness of the parental and family involvement policy in improving the academic quality of the schools served under the Title I

program, including identifying barriers to greater participation by parents and family members in Title I programs, with particular attention to parents and families who are economically disadvantaged, are disabled, have limited English proficiency, have limited literacy, or are of any racial or ethnic minority background, and use the findings of such evaluation to design strategies for more effective parental involvement, and to revise, if necessary, the parental and family involvement policies of the District.

- F. Involving parents and family members in the activities of the schools served under Title I.

#### Policy Involvement

Each school served under the Title I program shall:

- A. Convene an annual meeting, at a convenient time, to which all parents and family members of participating children shall be invited and encouraged to attend, to inform parents and family members of their school's participation under the Title I program and to explain the requirements of the Title I program.
- B. Offer a flexible number of meetings, such as meetings in the morning or evening. If sufficient funds are provided for this purpose, the District may assist parental and family involvement in such meetings by offering transportation, child care, or home visits.
- C. Involve parents and family members in an organized, ongoing, and timely way, in the planning, review, and improvement of Title I programs.
- D. Provide parents and family members of participating children—(1) timely information about programs under Title I, (2) a description and explanation of the curriculum in use at the school, the forms of academic assessment used to measure student progress, and the proficiency levels students are expected to meet; and (3) if requested by parents and family members, opportunities for regular meetings to formulate suggestions and to participate, as appropriate, in decisions relating to the education of their children, and respond to any such suggestions as soon as practicably possible.
- E. If the District operates a school-wide program under Title I and such plan is not satisfactory to the parents and family members of participating children, submit any parental or family members' comments on the plan when the school makes the plan available to the District.

#### Shared Responsibilities for High Student Academic Achievement

As a component of the District's parental and family involvement policy, each school served under the Title I program shall jointly develop with parents and family members for all children served under the Title I program a school-parent compact that outlines how parents, family members, the entire school staff, and students will share the responsibility for improved student academic achievement and the means by which the school, parents and family members will build and develop a partnership to help children achieve the State's high standards. Such

compact shall—(1) describe the school’s responsibility to provide high-quality curriculum and instruction in a supportive and effective learning environment that enables the children served under Title I to meet the State’s student academic achievement standards and the ways in which each parent and family will be responsible for supporting their children’s learning, such as monitoring attendance, homework completion, and television watching; volunteering in their child’s classroom; and participating, as appropriate, in decisions relating to the education of their children and positive use of extracurricular time; and (2) address the importance of communication between teachers, parents and family members on an ongoing basis through, at a minimum—(A) parent-teacher conferences in elementary schools, at least annually, during which the compact shall be discussed as the compact relates to the individual child’s achievement; (B) frequent reports to parents and family members on their children’s progress; and (C) reasonable access to staff, opportunities to volunteer and participate in their child’s class, and observation of classroom activities.

#### Building Capacity for Involvement

To ensure effective involvement of parents and family members and to support a partnership among the District, parents, family members, and the community to improve student academic achievement, each school participating in the Title I program and the District—(1) shall provide assistance to participating parents and family members, as appropriate, in understanding such topics as the State’s academic content standards and State student academic achievement standards, State and local academic assessments, the requirements of Title I and how to monitor a child’s progress and work with educators to improve the achievement of their children; (2) shall provide materials and training to help parents and family members to work with their children to improve their children’s achievement, such as literacy training and using technology (including education about the harms of copyright piracy), as appropriate, to foster parental and family member involvement; (3) shall educate teachers, student service personnel, principals, and other staff, with the assistance of parents and family members, in the value and utility of contributions of parents and family members, and in how to reach out to, communicate with, and work with parents and family members as equal partners, implement and coordinate parent and family programs, and build ties between parents, family members and the school; (4) shall, to the extent feasible and appropriate, coordinate and integrate parent and family involvement programs and activities with Head Start, Reading First, Early Reading First, Even Start, the Home Instruction Programs for Preschool Youngsters, the Parents as Teacher Program, and public preschool and other programs, and conduct other activities, such as parent and family resource centers, that encourage and support parents and family members in more fully participating in the education of their children; (5) shall ensure that information related to school and parent and family programs, meetings, and other activities is sent to the parents and family members of participating children in a format, and to the extent practicable, in a language the parents and family members can understand; (6) may involve parents and family members in the development of training for teachers, principals, and other educators to improve the effectiveness of such training; (7) may provide necessary literacy training from funds received under Title I if the District has exhausted all other reasonably available sources of funding for such training; (8) may pay reasonable and necessary expenses associated with parental and family involvement activities, including transportation and child care costs, to enable parents and family members to participate in school-related meetings and training sessions; (9) may train parents and family members to enhance the involvement of other parents and family members; (10) may arrange school meetings at a variety of times, or conduct in-home conferences between teachers or other educators, who work directly with participating children, with parents and family members who

are unable to attend such conferences at school, in order to maximize parental and family involvement and participation; (11) may adopt and implement model approaches to improving parental and family involvement; (12) may establish a district-wide parent and family advisory council to provide advice on all matters related to parental and family involvement in programs supported under Title I; (13) may develop appropriate roles for community-based organizations and businesses in parent and family involvement activities; and (14) shall provide such other reasonable support for parental and family involvement activities under Title I as parents and family members may request.

#### Accessibility

In carrying out the parental and family involvement activities for this Title I Parental and Family Involvement policy, the District shall provide full opportunities for the participation of parents and family members with limited English proficiency, parents and family members with disabilities, and parents and family members of migratory children, including providing information and school reports required under Title I in a format and, to the extent practicable, in a language such parents understand.

#### Use, Distribution, and Updating of this Policy

This Title I Parental and Family Involvement Policy shall be incorporated into the District's Title I plan, shall be distributed to parents and family members of participating children, shall be made available to the local community, and shall be updated periodically to meet the changing needs of the parents and family members and the school.

Legal Authorities: 20 U.S.C. §§6318 and 7801(32)

Date of Adoption: [Insert Date]

InstructionComputerInternet Safety and Acceptable Use PolicyA. Internet Safety Policy

It is the policy of [Name] Public Schools to comply with the Children's Internet Protection Act (CIPA) and Children's Online Privacy Protection Act (COPPA). With respect to the District's computer network, the District shall: (a) prevent user access to, or transmission of, inappropriate material via Internet, electronic mail, or other forms of direct electronic communications; (b) provide for the safety and security of minors when using electronic mail, chat rooms, and other forms of direct electronic communications; (c) prevent unauthorized access, including so-called "hacking," and other unlawful activities online; (d) prevent unauthorized online disclosure, use, or dissemination of personal identification information of minors; (e) obtain verifiable parental consent before allowing third parties to collect personal information online from students; and (f) implement measures designed to restrict minors' access to materials (visual or non-visual) that are harmful to minors.

1. Definitions. Key terms are as defined in CIPA. "Inappropriate material" for purposes of this policy includes material that is obscene, child pornography, or harmful to minors. The term "harmful to minors" means any picture, image, graphic image file, or other visual depiction that: (1) taken as a whole and with respect to minors, appeals to a prurient interest in nudity, sex, or excretion; (2) depicts, describes, or represents, in a patently offensive way with respect to what is suitable for minors, an actual or simulated sexual act or sexual contact, actual or simulated normal or perverted sexual acts, or a lewd exhibition of the genitals; and (3) taken as a whole, lacks serious literary, artistic, political, or scientific value as to minors.
2. Access to Inappropriate Material. To the extent practical, technology protection measures (or "Internet filters") shall be used to block or filter Internet, or other forms of electronic communications, access to inappropriate information. Specifically, as required by the CIPA, blocking shall be applied to visual depictions of material deemed obscene or child pornography, or to any material deemed harmful to minors. Subject to staff supervision, technology protection measures may be disabled or, in the case of minors, minimized only for bona fide research or other lawful purposes.
3. Inappropriate Network Usage. To the extent practical, steps shall be taken to promote the safety and security of users of the District's online computer network when using electronic mail, chat rooms, instant messaging, and other forms of direct electronic communications. Specifically, as required by CIPA, prevention of inappropriate network usage includes: (a) unauthorized access, including so-called 'hacking,' and other unlawful activities; and (b) unauthorized disclosure, use, and dissemination of personal identification information regarding minors.

4. Supervision and Monitoring. It shall be the responsibility of all members of the District staff to supervise and monitor usage of the online computer network and access to the Internet in accordance with this policy and CIPA. Procedures for the disabling or otherwise modifying any technology protection measures shall be the responsibility of the Superintendent and the Superintendent's designees.
5. Social Networking. Students shall be educated about appropriate online behavior, including interacting with others on social networking websites and in chat rooms, and cyberbullying awareness and response. The plan shall be for all students to be provided education on these subjects. The Superintendent or the Superintendent's designee shall be responsible for identifying educational materials, lessons, and/or programs suitable for the age and maturity level of the students and for ensuring the delivery of such materials, lessons, and/or programs to students.
6. Parental Consent. The District shall obtain verifiable parental consent prior to students providing or otherwise disclosing personal information online.
7. Adoption. This Internet Safety Policy was adopted by the Board at a public meeting, following normal public notice.

B. Computer Acceptable Use Policy

This computer acceptable use policy is supplemental to the District's Internet Safety Policy.

1. Technology Subject to this Policy. This Computer Acceptable Use Policy applies to all technology resources of the District or made available by the District. Technology resources include, without limitation, computers and related technology equipment, all forms of e-mail and electronic communications, and the internet.
2. Access and User Agreements. Use of the District technology resources is a privilege and not a right. The Superintendent or designee shall develop appropriate user agreements and shall require that employees, students (and their parents or guardians), and others to sign such user agreements as a condition of access to the technology resources, as the Superintendent determines appropriate. Parents and guardians of students in programs operated by the District shall inform the Superintendent or designee in writing if they do not want their child to have access.

The Superintendent and designees are authorized and directed to establish and implement such other regulations, forms, procedures, guidelines, and standards to implement this Policy.

The technology resources are not a public forum. The District reserves the right to restrict any communications and to remove communications that have been posted.

3. Acceptable Uses. The technology resources are to be used for the limited purpose of advancing the District's mission. The technology resources are to be used, in general, for educational purposes, meaning activities that are integral, immediate, and proximate to the education of students as defined in the E-rate program regulations.
4. Unacceptable Uses.

The following are unacceptable uses of the technology resources:

- a. **Personal Gain:** Technology resources shall not be used, and no person shall authorize its use, for personal financial gain other than in accordance with prescribed constitutional, statutory, and regulatory procedures, other than compensation provided by law.
- b. **Personal Matters:** Technology resources shall not be used, and no person shall authorize its use, for personal matters unless the User has entered into a lease agreement or other similar agreement with the School District that makes such use permissible under law.

Occasional use that the Superintendent or designee determines to ultimately facilitate the mission of the District is not prohibited by this provision. Examples of occasional use that may be determined to ultimately facilitate the mission of the District: sending an e-mail to a minor child or spouse; sending an e-mail related to a community group in which an employee is a member where the membership in the community group facilitates the District's mission.

This occasional use exception does not permit use by employees contrary to the expectations of their position. For example, employees may not play games or surf the net for purposes not directly related to their job during duty time; nor may students do so during instructional time.

The occasional use exception also does not permit use of the technology resources for private business, such as searching for or ordering items on the internet for non-school use; or sending an e-mail related to one's own private consulting business.

- c. **Campaigning:** Technology resources shall not be used, and no person shall authorize its use, for the purpose of campaigning for or against the nomination or election of a candidate or the qualification, passage, or defeat of a ballot question.
- d. **Technology-Related Limitations:** Technology resources shall not be used in any manner which impairs its effective operations or the rights of other technology users. Without limitation,

1. Users shall not use another person's name, log-on, password, or files for any reason, or allow another to use their password (except for authorized staff members).
  2. Users shall not erase, remake, or make unusable another person's computer, information, files, programs or disks.
  3. Users shall not access resources not specifically granted to the user or engage in electronic trespassing.
  4. Users shall not engage in "hacking" to gain unauthorized access to the operating system software or unauthorized access to the system of other users.
  5. Users shall not copy, change, or transfer any software without permission from the network administrators.
  6. Users shall not write, produce, generate, copy, propagate, or attempt to introduce any computer code designed to self-replicate, damage, or otherwise hinder the performance of any computer's memory, file system, or software. Such software is often called a bug, virus, worm, Trojan horse, or similar name.
  7. Users shall not engage in any form of vandalism of the technology resources.
  8. Users shall follow the generally accepted rules of network etiquette. The Superintendent or designees may further define such rules.
- e. Other Policies and Laws: Technology resources shall not be used for any purpose contrary to any District policy, any school rules to which a student user is subject, or any applicable law. Without limitation, this means that technology resources may not be used:
1. to access any material contrary to the Internet Safety Policy; or to create or generate any such material.
  2. to engage in unlawful harassment or discrimination, such as sending e-mails that contain sexual jokes or images.
  3. to engage in violations of employee ethical standards and employee standards of performance, such as sending e-mails that are threatening or offensive or which contain abusive language; use of end messages on e-mails that may imply that the District is supportive of a particular religion or religious belief system, a political candidate or issue, or a controversial issue; or sending e-mails that divulge protected confidential student information to unauthorized persons.
  4. to engage in or promote violations of student conduct rules.
  5. to engage in illegal activity, such as gambling.
  6. in a manner contrary to copyright laws.
  7. in a manner contrary to software licenses.
5. Disclaimer. The technology resources are supplied on an "as is, as available" basis. The District does not imply or expressly warrant that any information accessed will be valuable or fit for a particular purpose or that the system will

operate error free. The District is not responsible for the integrity of information accessed, or software downloaded from the Internet.

6. Filter. A technology protection measure is in place that blocks and/or filters access to prevent access to Internet sites that are not in accordance with policies and regulations. In addition to blocks and/or filters, the District may also use other technology protection measures or procedures as deemed appropriate.

Notwithstanding technology protection measures, some inappropriate material may be accessible by the Internet, including material that is illegal, defamatory, inaccurate, or potentially offensive to some people. Users accept the risk of access to such material and responsibility for promptly exiting any such material.

The technology protection measure that blocks and/or filters Internet access may be disabled only by an authorized staff member for bona fide research or educational purposes: (a) who has successfully completed District training on proper disabling circumstances and procedures, (b) with permission of the immediate supervisor of the staff member requesting said disabling, or (c) with the permission of the Superintendent. An authorized staff member may override the technology protection measure that blocks and/or filters Internet access for a minor to access a site for bona fide research or other lawful purposes provided the minor is monitored directly by an authorized staff member.

7. Monitoring. Use of the technology resources, including but not limited to internet sites visited and e-mail transmitted or received, is subject to monitoring by the administration and network administrators at any time to maintain the system and insure that users are using the system responsibly, without notice to the users. Users have no privacy rights or expectations of privacy with regard to use of the District's computers or Internet system. All technology equipment shall be used under the supervision of the Superintendent and the Superintendent's designees.
8. Sanctions. Violation of the policies and procedures concerning the use of the District technology resources may result in suspension or cancellation of the privilege to use the technology resources and disciplinary action, up to and including expulsion of students and termination of employees. Use that is unethical may be reported to the Commissioner of Education. Use that is unlawful may be reported to the law enforcement authorities. Users shall be responsible for damages caused and injuries sustained by improper or non-permitted use.

Legal Reference: Children's Internet Protection Act, 47 USC § 254  
 Children's Online Privacy Protection Act, 15 U.S.C. § 6501  
 FCC Order adopted August 10, 2011  
 47 USC § 254(h)(1)(b); 47 CFR 54.500(b) and 68 FR 36932 (2003) (E-rate restrictions)  
 Neb. Rev. Stat. § 49-14,101.01 (Political Accountability and Disclosure Act)

Date of Adoption: [Insert Date]

[Name] Public Schools  
Addition to Employee Code of Conduct  
*Appendix "1"*

ACCEPTABLE USE OF COMPUTERS AND NETWORKS

ADMINISTRATORS, FACULTY AND STAFF AGREEMENT

In order to make sure that all members of [Name] Public Schools community understand and agree to these rules of conduct for use of the e-mail and Internet systems of the school district, the [Name] Public School District asks that you, as an administrator, faculty member, or staff member user, sign the following statement:

I have received a copy of, and have read, the Internet Safety and Acceptable Use Policy adopted by the [Name] Public Schools, and I understand and will abide by those district guidelines and conditions for the use of the facilities of [Name] Public Schools and access to the Internet. I further understand that any violation of the district guidelines is unethical and may constitute a criminal offense. Should I commit any violation, my access privileges will be revoked. School disciplinary action and/or appropriate legal action will be taken.

I agree not to hold the [Name] Public Schools, any of its employees, or any institution providing network access to [Name] Public Schools responsible for the performance of the system or the content of any material accessed through it.

Employee's Name \_\_\_\_\_

Employee's Signature \_\_\_\_\_ Date: \_\_\_\_\_

This form will be retained on file by authorized  
faculty designee for duration of applicable  
computer/network/Internet use.

[Name] Public Schools  
Addition to Student Code of Conduct  
*Appendix "2"*

ACCEPTABLE USE OF COMPUTERS AND NETWORKS

STUDENT'S AGREEMENT

In order to make sure that all members of [Name] Public Schools community understand and agree to these rules of conduct, [Name] Public Schools asks that you as a student user sign the following statement:

I have received a copy of, and have read, the Internet Safety and Acceptable Use Policy adopted by the [Name] Public Schools, and I understand and will abide by those district guidelines and conditions for the use of the facilities of [Name] Public Schools and access to the Internet. I further understand that any violation of the district guidelines is unethical and may constitute a criminal offense. Should I commit any violation, my access privileges will be revoked. School disciplinary action and/or appropriate legal action will be taken.

I agree not to hold the [Name] Public Schools, any of its employees, or any institution providing network access to [Name] Public Schools responsible for the performance of the system or the content of any material accessed through it.

Student's Name \_\_\_\_\_

Student's Signature \_\_\_\_\_ Date: \_\_\_\_\_

This form will be retained on file by authorized faculty designee for duration of applicable computer/network/Internet use.

[Name] Public Schools  
Addition to Student Code of Conduct  
*Appendix "3"*

ACCEPTABLE USE OF COMPUTERS AND NETWORKS

PARENT’S AGREEMENT

In order to make sure that all members of [Name] Public Schools community understand and agree to these rules of conduct, we ask that you as a parent/guardian sign the following statement:

I have received a copy of, and have read, the Internet Safety and Acceptable Use Policy adopted by [Name] Public Schools. As parent or guardian of the student named below, I grant permission for my son or daughter to access networked computer services such as electronic mail (e-mail) and the Internet. I understand that this free access is designed for educational purposes. I also understand that individuals may be held liable for violations of those Terms and Conditions. However, I also recognize that it is impossible to restrict access to all controversial materials and I will not hold [Name] Public Schools responsible for materials acquired or sent via the network.

I agree not to hold the [Name] Public Schools, any of its employees, or any institution providing network access to [Name] Public Schools responsible for the performance of the system or the content of any material accessed through it.

Student's Name \_\_\_\_\_

Parent's Signature \_\_\_\_\_ Date: \_\_\_\_\_

This form will be retained on file by authorized faculty designee for duration of applicable computer/network/Internet use.

InstructionStudent Self-Management of Asthma, Anaphylaxis, and/or Diabetes

Students with asthma, anaphylaxis or diabetes will be permitted to self-manage such medical conditions upon:

- (1) written request of the student's parent or guardian;
- (2) authorization of the student's physician or, for asthma and anaphylaxis, a health care professional who prescribed the medication for treatment of the student's condition;
- (3) receipt of a signed no liability statement from the parent or guardian; and
- (4) development of an asthma or anaphylaxis or a diabetes medical management plan for the student.

Students with such a medical management plan may possess the necessary medication to manage their medical condition upon the conditions established in the plan and not be subject to discipline for such possession. Provided that, if the student uses or allows the medication to be used for any reason other than as prescribed or as provided in the plan or possesses the medication other than as provided in the plan the student shall be subject to discipline in accordance with the student conduct and drug-free school policies.

Legal Reference: Neb. Rev. Stat. §§ 79-224 and 79-225

Date of Adoption: [Insert Date]

Plan For \_\_\_\_\_ (Student) Dated: \_\_\_\_\_

**ASTHMA OR ANAPHYLAXIS MEDICAL MANAGEMENT PLAN**

**I. CONTACT AND PLAN INFORMATION**

Student's Name: \_\_\_\_\_ Date of Birth: \_\_\_\_/\_\_\_\_/\_\_\_\_

(Month) (Day) (Year)

Health Condition:  Asthma  Anaphylaxis (For this Plan "Health Condition" means the condition(s) checked)

Mother/Guardian: \_\_\_\_\_

Address: \_\_\_\_\_

Telephone: Home \_\_\_\_\_ Work \_\_\_\_\_ Cell \_\_\_\_\_

Father/Guardian: \_\_\_\_\_

Address: \_\_\_\_\_

Telephone: Home \_\_\_\_\_ Work \_\_\_\_\_ Cell \_\_\_\_\_

Student's Doctor/Health Care Provider: \_\_\_\_\_

Address: \_\_\_\_\_

Telephone: \_\_\_\_\_ Emergency Number: \_\_\_\_\_

Other Emergency Contacts: \_\_\_\_\_

Relationship: \_\_\_\_\_

Telephone: Home \_\_\_\_\_ Work \_\_\_\_\_ Cell \_\_\_\_\_

**II. PARENT OR GUARDIAN  
AUTHORIZATION, APPROVAL AND LIABILITY WAIVER**

The parents or guardians (hereinafter "Parent") request that [Name] Public Schools allow the Student to self-manage the health condition and accept and agree to this Medical Management Plan. The Guidelines for Asthma or Anaphylaxis Medical Management Plan are incorporated into and are a part of this Plan.

Parents understand and agree that if the Student injures school personnel or another student as the result of the misuse of necessary asthma or anaphylaxis medical supplies, Parents shall be responsible for any and all costs associated with such injury. Parents acknowledge that (a) the school and its employees and agents are not liable for any injury or death arising from the Student's self-management of the Student's Health Condition and Parents release same from any such claims and (b) Parents shall and do hereby agree to indemnify and hold harmless the school and its employees and agents against any claim arising from the Student's self-management of Student's Health Condition. This release, indemnification and hold harmless agreement shall take effect immediately and shall stay in effect for as long as the Student is provided permission to self-administer medication.

Parent/guardian signature: \_\_\_\_\_ Date: \_\_\_\_\_

Parent/guardian signature: \_\_\_\_\_ Date: \_\_\_\_\_

**III. STUDENT AGREEMENT**

I will use the prescription asthma or anaphylaxis medication only as prescribed and as permitted by the Plan. I will not share the medication with others and I will not create an unnecessary distraction to others. I have been instructed how to self-administer this medication and understand the side effects of improper use and will promptly report self-administration and follow the Guidelines. I understand that if I do not abide by these terms, I may be disciplined and that this Plan will be re-evaluated. I release the school and its employees of any liability in any way related to this Plan or my use of the medication.

Student signature: \_\_\_\_\_ Date: \_\_\_\_\_

**IV. MEDICAL MANAGEMENT PLAN**

**A. Health care services the Student may receive at school relating to Student’s Health Condition:** See Guidelines (Part V).

**B. Evaluation of Student’s understanding of and ability to self-manage Student’s Health Condition.**

The parents/guardians and the Physician certify that the Student has a sufficient level of understanding and ability to self-manage the Student’s Health Condition as follows:

1. Access to Prescription Asthma/Anaphylaxis Medication
  - May have medication in Student’s possession at any time.
  - May have medication in Student’s possession when the health office is not accessible (for example, when the Student is out of the school on field trips or participating in extracurricular activities) but should otherwise be maintained in the health office.
  - May not have medication in Student’s possession except for emergency use.
2. Self-Administration of Prescription Asthma/Anaphylaxis Medication
  - May self-administer independently and without supervision. The Student has had training and is proficient in self-administering medication.
  - May self-administer when the health office or school staff authorized to administer medication are not readily accessible (for example, when the Student is out of the school on field trips or participating in extracurricular activities); but should otherwise have medication administered by the health office or authorized school staff.
  - May not self-administer except for emergency use.

**C. It is agreed that this Plan permits regular monitoring of Student’s self-management of Student’s Health Condition by an appropriately credentialed health care professional.**

**D. Name, purpose and dosage of prescription asthma or anaphylaxis medication prescribed for Student:** See Student Asthma/Anaphylaxis Action Plan (Part IV(F)).

**E. Procedures for storage and access to backup supplies of such prescription medication for Student’s Health Condition:**

1. The Student, when permitted to be in possession of medication, will have only the prescription medication that might be needed for the Student’s own use. For example, the Student may have one inhaler, but not two, unless the first is nearly empty
2. The school will store any backup supply needed in accordance with its medication storage procedures.
3. The student may have access to the backup supply when necessary by requesting such from the health office.

**F. Student Asthma/Anaphylaxis Action Plan**

**Student Name:** \_\_\_\_\_ **Date of Birth:** \_\_\_\_/\_\_\_\_/\_\_\_\_  
 (Month) (Day) (Year)

**EXERCISE PRECAUTION** - Administer inhaler 15-30 minutes before exercise (eg, gym class, recess)

Albuterol inhaler (Proventil, Ventolin) 2 inhalations

<p><b><u>ASTHMA TREATMENT</u></b>                  Give or self-administer <b>quick relief medication</b> when Student experiences asthma symptoms such as, coughing, wheezing, or tight chest.  <b>Quick relief medication:</b></p> <p><input type="checkbox"/> Albuterol inhaler (Proventil, Ventolin) 2 inhalations</p> <p><input type="checkbox"/> Pirbuterol inhaler (Maxair) 2 inhalations</p> <p><input type="checkbox"/> Albuterol inhaled <i>by nebulizer</i> (Proventil, Ventolin)</p> <p style="padding-left: 40px;"><input type="checkbox"/> 0.63 mg/3 mL</p> <p style="padding-left: 40px;"><input type="checkbox"/> 1.25 mg/3 mL</p> <p><input type="checkbox"/> Levalbuterol inhaled <i>by nebulizer</i> (Xopenex)</p> <p style="padding-left: 40px;"><input type="checkbox"/> 0.31 mg/3 mL</p> <p style="padding-left: 40px;"><input type="checkbox"/> 0.63 mg/3 mL</p> <p style="padding-left: 40px;"><input type="checkbox"/> 1.25 mg/3 mL</p> <p><input type="checkbox"/> May carry and self-administer metered-dose inhaler per Part IV(B) of Medical Management Plan.</p>	<p><b>IF SCHOOL STAFF INVOLVED-- CLOSELY OBSERVE STUDENT AFTER QUICK RELIEF ASTHMA MEDICATION IS ADMINISTERED</b></p> <p><b>If after 10 minutes:</b></p> <ul style="list-style-type: none"> <li>• Symptoms are improved, student may return to classroom after notifying parent/guardian.</li> <li>• If no improvement in symptoms, repeat the above medication and notify parent/guardian immediately and determine student’s ability to remain in school for the day.</li> <li>• <b><i>If student continues to worsen CALL 911 and INITIATE Emergency Response to Life-Threatening Asthma or Systemic Allergic Reactions Protocol (Asthma).</i></b></li> </ul>
--	--

<p><b><u>ANAPHYLAXIS TREATMENT</u></b>                  Give or self-administer <b>epinephrine</b> when Student experiences allergy symptoms, such as hives, difficulty breathing (chest or neck “sucking in”), lips or fingernails turning blue, or trouble talking (shortness of breath).</p> <p><input type="checkbox"/> The Student has severe allergies to the following:                  _____</p> <p><input type="checkbox"/> Epinephrine injection (please specify):</p> <p style="padding-left: 40px;"><input type="checkbox"/> EpiPen 0.3 mg                      <input type="checkbox"/> Twinject 0.3 mg</p> <p style="padding-left: 40px;"><input type="checkbox"/> EpiPen Jr. 0.15 mg                  <input type="checkbox"/> Twinject 0.15 mg</p> <p><input type="checkbox"/> May carry and self-administer epinephrine injection per Part IV(B) Medical Management Plan.</p>	<p><b>IF SCHOOL STAFF INVOLVED--CLOSELY OBSERVE STUDENT AFTER EPINEPHRINE IS ADMINISTERED</b></p> <ul style="list-style-type: none"> <li>• <b><i>CALL 911 and closely observe the student.</i></b></li> <li>• Notify parent/guardian immediately.</li> <li>• Even if student improves, the student should be observed for recurrent symptoms of anaphylaxis in an emergency medical facility.</li> <li>• <b><i>If student does not improve or continues to worsen, INITIATE Nebraska’s schools Emergency Response to Life-Threatening Asthma or Systemic Allergic Reactions Protocol (Anaphylaxis).</i></b></li> </ul>
---	--

Possible adverse reactions to be reported to physician \_\_\_\_\_

Special instructions \_\_\_\_\_

I am the Student’s Physician or other health care professional who prescribed the medication for treatment of the student's condition. Student has  Asthma  Anaphylaxis and has been prescribed the medication referenced above. Student has the ability to safely and responsibly self-manage Student’s Health Condition in accordance with this Asthma or Anaphylaxis Medical Management Plan. I approve the Medical Management Plan and the Student Asthma/Anaphylaxis Action Plan and authorize Student to self-manage Student’s Health Condition at school in accordance with the Plan.

Physician signature: \_\_\_\_\_ Date: \_\_\_\_\_

**V. GUIDELINES FOR  
ASTHMA OR ANAPHYLAXIS MEDICAL MANAGEMENT PLAN**

**Term of Plan:** The plan is effective for the current school year. A new plan must be established each school year or more often if changes occur to the student’s health or prescribed treatment or student’s ability to self-manage.

**Medications:** The parents or guardians are responsible for supplying any and all prescription asthma/anaphylaxis medications required under the Plan; the school is not responsible for providing the medications. Prescribed asthma/anaphylaxis medications to be used by the Student under this Plan must be furnished in a current original container from the pharmacy with the student's name and the name of the medication, and where applicable, the strength and the dosage to be given. Inhalers must have a label attached to the inhaler itself, not on the packaging. If the prescribed medication, dosage or time of medication changes, the parents or guardians must promptly submit to the school nurse or designee the new prescription and as necessary a new asthma/anaphylaxis action plan. Any non-prescription medication must be furnished in the original container from the manufacturer. The school will store any backup supply needed in accordance with its medication storage procedures. The student may have access to the backup supply when necessary by requesting such from the health office.

**Health care services the Student may receive at school relating to Student’s Health Condition.**

1. Standard health services available to all students.
2. Storage of backup asthma or anaphylaxis medication supplies.
3. Recording of student self-administration reports.

**Consultations:** The school may consult with a registered nurse or other health care professional employed by such school during development of the plan.

**Permitted Self-Management:** Pursuant to the Asthma or Anaphylaxis Medical Management Plan the Student shall be permitted to self-manage the Student’s asthma or anaphylaxis condition in the classroom or any part of the school or on school grounds, during any school-related activity, or in any private location specified in the plan.

**Student Reports of Self-Administration:** The Student shall promptly notify the school nurse, the school nurse’s designee, or another designated adult at the school when the Student has self-administered prescription asthma or anaphylaxis medication pursuant to the Plan.

**Responses to Student Misuse:** The possession of medications by Students is a violation of the school’s drug and student conduct policies and may result in an expulsion from school. To the extent this Asthma or Anaphylaxis Medical Management Plan permits the Student to be in possession of prescribed asthma/anaphylaxis medications, the Plan allows the Student an exception to the school drug and student conduct policies. However, this exception only extends to the extent provided in the Plan. In the event the Student uses his or her prescription asthma or anaphylaxis medication other than as prescribed, or possesses medication other than as permitted by the Plan, the Student is subject to disciplinary action by the school, up to and including an expulsion. The school will promptly notify the parent or guardian of any disciplinary action imposed. The disciplinary action will not include a limitation or restriction on the student’s access to such medication; however, it is agreed that in the event of any such misuse, a re-evaluation of the Student’s understanding of and ability to self-manage Student’s Health Condition will occur and the re-evaluation may result in a modification or termination of this Plan.

**Sharing Plan:** It is agreed that this Asthma or Anaphylaxis Medical Management Plan may be shared with school officials and agents who have a need to be aware of it; that those who have the need to be aware of it include student health staff and also include staff responsible for student discipline (e.g. staff need to know that the Student is authorized to have the medication on the

Student's person so the Student is not reported for a violation of the school's drug policies). The school officials who may be informed of the Plan thus include: administration, school nurse, school office staff, teachers and any paraeducators or specialists who provide services to the Student, and the coaches and sponsors of extracurricular activities in which the Student participates.

**Filing of Plan:** This Asthma or Anaphylaxis Medical Management Plan is to be kept on file at the school where the Student is enrolled.

**VI. SCHOOL NURSE ACKNOWLEDGEMENT OF  
ASTHMA OR ANAPHYLAXIS MEDICAL MANAGEMENT PLAN**

- Parent Request and Liability Waiver signed  Student Agreement signed.
- Management Plan (including Action Plan) signed by Physician.
- Guidelines reviewed with the Student and Parent/Guardian.
- Copy of Guidelines and Student Agreement received by Parent/Guardian for reference.

School Nurse or designee signature: \_\_\_\_\_ Date: \_\_\_\_\_

### Asthma/Allergy Self-Management Log

**Student Name** \_\_\_\_\_

**Student Date of Birth** \_\_\_\_\_

Date Started	Medication	Dosage	Time	Frequency	Physician	Phone #

Date/time of report	Date/time administration	Observation/Complications	Employee Recording Student Report	Parent Notification
				Date: _____ <input type="checkbox"/> Phone <input type="checkbox"/> Form
				Date: _____ <input type="checkbox"/> Phone <input type="checkbox"/> Form
				Date: _____ <input type="checkbox"/> Phone <input type="checkbox"/> Form
				Date: _____ <input type="checkbox"/> Phone <input type="checkbox"/> Form
				Date: _____ <input type="checkbox"/> Phone <input type="checkbox"/> Form
				Date: _____ <input type="checkbox"/> Phone <input type="checkbox"/> Form
				Date: _____ <input type="checkbox"/> Phone <input type="checkbox"/> Form
				Date: _____ <input type="checkbox"/> Phone <input type="checkbox"/> Form
				Date: _____ <input type="checkbox"/> Phone <input type="checkbox"/> Form

Parents/Guardian \_\_\_\_\_ Phone \_\_\_\_\_

Teacher \_\_\_\_\_ Grade \_\_\_\_\_

Internal Board PoliciesConflict of Interest—Other Than Contracts or Employment

1. Members of the Board of Education of this School District shall abstain from voting on matters on which they may have a conflict of interest. Any Board member who would be required to take any action or make any decision in the discharge of his or her duties that may cause financial benefit or detriment to him or her, a member of his or her immediate family, or a business with which he or she is associated, which is distinguishable from the effects of such action on the public generally or a broad segment of the public, shall take the following actions as soon as he or she is aware of such potential conflict or should reasonably be aware of such potential conflict, whichever is sooner:

- (A) Prepare a written statement describing the matter requiring action or decision and the nature of the potential conflict; and,
- (B) Deliver a copy of the statement to the Secretary of the Board of Education, who shall enter the statement into the public records of the School District.

The Board member shall take such action as the Commission shall advise or prescribe to remove himself or herself from influence over the action or decision in the matter.

2. The provisions of paragraph 1 above shall not prevent a Board member from making or participating in the making of a School District-related decision to the extent that the individual's participation is legally required for the action or decision to be made. In such event, the Board member shall report the occurrence to the Commission.

3. Except as defined in Nebraska statute and this policy, conflict of interest of a Board member shall not prevent a Board member from serving on the Board or restrict the hiring or purchasing practices of this School District.

4. The Superintendent, or the Superintendent's designee, shall provide:
- (A) Each Board member with copies of state statutes of Nebraska pertaining to conflicts of interest at the organizational meeting of the Board of Education held at the regular School Board meeting in January of each year. In addition, any newly appointed or elected Board member shall be provided such statutes.
  - (B) When possible, provide each Board member with a list of financial matters on the agenda to come before the Board of Education at the next regular meeting in sufficient detail to allow the Board member to identify potential conflicts of interest and report and receive advice from the Commission.

5. For purposes of this policy, immediate family member shall be defined as a child residing in the Board member's household, a Board member's spouse or an individual claimed by that Board member or the Board member's spouse as a dependent for federal income tax purposes.

Legal Reference: Neb. Rev. Stat. § 49-1425; § 49-14,101; § 49-14,102; § 49-14,103; § 49-14,103.01; § 49-14,103.02; § 49-14,103.03; § 49-14,103.04; § 49-14,103.05; § 49-14,103.06; § 79-818; § 79-544 and § 49-1499.

Date of Adoption: [Insert Date]

Bylaws of the Board - Meetings

Voting

Any action taken on any question or motion duly moved and seconded shall be by roll call vote of the Board in open session, and the record shall state how each member voted, or if the member was absent or not voting. The requirements of a roll call or viva voce vote may be satisfied by use of an electronic voting device which allows the yeas and nays of each member of the board to be readily seen by the public.

Date of Adoption: [Insert Date]

John M. Guthery  
Thomas M. Haase  
James B. Gessford  
Rex R. Schultze\*\*\*  
Daniel F. Kaplan  
Gregory H. Perry  
Joseph F. Bachmann\*  
R.J. Shortridge\*  
Jeanette Stull  
Corey L. Stull\*  
Joshua J. Schauer \*  
Derek A. Aldridge\*\*  
Justin J. Knight\*\*\*\*  
Charles Kaplan



---

PERRY, GUTHERY, HAASE & GESSFORD, P.C., L.L.O.  
233 SOUTH 13TH STREET, SUITE 1400  
LINCOLN, NEBRASKA 68508  
TELEPHONE (402) 476-9200 • FAX (402) 476-0094  
www.perrylawfirm.com

Of Counsel  
Richard D. Sievers  
Kelley Baker

---

\*Also Admitted in Iowa  
\*\*Also Admitted in Kansas  
\*\*\*Also Admitted in Wyoming  
\*\*\*\*Also Admitted in Colorado

---

Ernest B. Perry (1876-1962)  
Arthur E. Perry (1910-1982)  
R.R. Perry (1917-1999)  
Edwin C. Perry (1931-2012)

## Perry Law Firm 2016 Annual Policy Update Service

**To:** Marge Beatty, Administrator, ESU 16  
**From:** Gregory H. Perry and Rex R. Schultze  
**Date:** June 7, 2016

This is the 2016 Annual Policy Update.

For policies that are not entirely new, we have provided both “redline” and “clean” versions.

### 1. Policy 3090—Sale and Disposal of Property

Policy 3090 was changed to include the sale of real estate. In addition, approval of any sale of school property was changed from requiring four members, to two-thirds of the members of the Board of Education, at a regular meeting.<sup>1</sup>

### 2. Policy 3130—Purchasing Policies

As a result of the State Auditor’s increased attention to and scrutiny of credit card use, we have added a section for the use of credit cards for purchases on behalf of the School District. The procedures set forth in the section of Policy 3130 should satisfy the State Auditor.

### 3. Policy 3570 – ESSA

The Every Student Succeeds Act was signed on December 10, 2015. The law requires that schools that receive Title I funding:

- Notify parents of the right to receive information about the professional qualifications of their child’s teachers;
- Notify parents that they may opt out of testing; and
- Notify parents of certain matters related opportunities related to the Language Instruction (ELL) program.

---

<sup>1</sup> Section 79-10,114 requires a vote of “at least two-thirds of all members of the board” for the sale of school property.

#### 4. Policy 4026—Prohibition on Aiding and Abetting Sexual Abuse

Section 8038 of the ESSA requires school districts to have a policy prohibiting helping a person get a job if it is known that the person engaged in sexual misconduct regarding a minor or a student in violation of the law.<sup>2</sup>

Policy 4026 has been prepared to comply with this part of the ESSA.

---

<sup>2</sup> SEC. 8038. PROHIBITION ON AIDING AND ABETTING SEXUAL ABUSE.

Subpart 2 of part F of title VIII, as amended and redesignated by section 8001 of this Act, is further amended by adding at the end the following:

“SEC. 8546. PROHIBITION ON AIDING AND ABETTING SEXUAL ABUSE.

“(a) IN GENERAL.—A State, State educational agency, or local educational agency in the case of a local educational agency that receives Federal funds under this Act shall have laws, regulations, or policies that prohibit any individual who is a school employee, contractor, or agent, or any State educational agency or local educational agency, from assisting a school employee, contractor, or agent in obtaining a new job, apart from the routine transmission of administrative and personnel files, if the individual or agency knows, or has probable cause to believe, that such school employee, contractor, or agent engaged in sexual misconduct regarding a minor or student in violation of the law.

“(b) EXCEPTION.—The requirements of subsection (a) shall not apply if the information giving rise to probable cause—

“(1)(A) has been properly reported to a law enforcement agency with jurisdiction over the alleged misconduct; and

“(B) has been properly reported to any other authorities as required by Federal, State, or local law, including title IX of the Education Amendments of 1972 (20 U.S.C. 1681 et seq.) and the regulations implementing such title under part 106 of title 34, Code of Federal Regulations, or any succeeding regulations; and

“(2)(A) the matter has been officially closed or the prosecutor or police with jurisdiction over the alleged misconduct has investigated the allegations and notified school officials that there is insufficient information to establish probable cause that the school employee, contractor, or agent engaged in sexual misconduct regarding a minor or student in violation of the law;

“(B) the school employee, contractor, or agent has been charged with, and acquitted or otherwise exonerated of the alleged misconduct; or

“(C) the case or investigation remains open and there have been no charges filed against, or indictment of, the school employee, contractor, or agent within 4 years of the date on which the information was reported to a law enforcement agency.

“(c) PROHIBITION.—The Secretary shall not have the authority to mandate, direct, or control the specific measures adopted by a State, State educational agency, or local educational agency under this section.

“(d) CONSTRUCTION.—Nothing in this section shall be construed to prevent a State from adopting, or to override a State law, regulation, or policy that provides, greater or additional protections to prohibit any individual who is a school employee, contractor, or agent, or any State educational agency or local educational agency, from assisting a school employee who engaged in sexual misconduct regarding a minor or student in violation of the law in obtaining a new job.”

**5. Policy 4027 – Workplace Privacy Act**

LB 821 prohibits employers from accessing employees’ electronic information, including passwords to social media accounts.

**6. Policy 5006 – Option Enrollment**

LB 1066 amended Nebraska’s Option Enrollment statute. Specifically, LB 1066 provides that, when adopting standards for accepting or denying late-filed applications (applications filed after March 15) as follows: “Standards shall not include that a request occurred after the deadline set forth in this subsection.”

The option enrollment policy we provided previously had included an option of denying an application for the sole reason that the application was filed late. In response to LB 1066, we have deleted that as an option. If your current policy uses that as an option, you will need to amend your policy. If your policy uses different reasons for accepting or denying an application than simply that the application was filed late, you do not need to amend the standards in your policy.

LB 1067 amended the option enrollment statutes to state: “Option students who qualify for free lunches shall be eligible for either free transportation or transportation reimbursement as described in section 79-611 from the option school district pursuant to policies established by the school district . . .” We have revised the option policy to meet this requirement.

**7. Policy 5203—Academic Progress**

Policy 5203 requires the academic reports (e.g. report cards) be “sent” to parents each quarter. With many schools now using electronic student records systems, it is not quite accurate to say that report cards are “sent” to parents. So we have changed the term to “made available.”

**8. Policy 5418—Homeless Student Policy**

Schools that have been audited by the NDE in the last year have been advised of the need to have a homeless policy with a more robust grievance procedure. Accordingly, Policy 5418 has been amended to provide an enhanced grievance procedure.

The ESSA also added a notice requirement that is reflected in the revised Policy 5418.

We have also removed the NCLB reference in the homeless policy forms.

**9. Policy 5419 – Mental Health Assessments or Reporting**

The ESSA requires that parental consent be obtained prior to a child under the age of 18 participating in any mental health assessment or service. We have revised Policy 5419 to meet this requirement.

**10. Policy 6020—ESSA-Copyright instruction**

The ESSA requires that students be given education about the harms of copyright piracy. We have revised Policy 6020 to incorporate this requirement.

**11. Policy 6212—Assessments—Academic Content Standards**

The statute related to adoption of state standards<sup>3</sup> requires districts to adopt academic content standards in the subject areas of reading, writing, mathematics, science, and social studies in accordance with timelines established by the State Board of Education, but in no event later than one year following the adoption or modification of state standards.

We have amended Policy 6212 to incorporate the Mathematics standards that were adopted by the State Board in September, 2015.

**12. Policy 6284—Initiations, Hazing, Secret Clubs and Outside Organizations**

The anti-hazing statute<sup>4</sup> had formerly been applicable only to post-secondary students. LB 710 extended the statute to include everyone. LB 710 also expanded the list of what constitutes hazing.

Policy 6284 was developed in 2013 even though the anti-hazing statute had not yet been extended to public school students. We have now revised the policy to include the additional hazing activities that were added by LB 710.

**13. Policy 6286—Return to Learn from Cancer**

LB 511 from the 2015 legislative session requires schools to “establish a return-to-learn protocol for students returning to school after being treated for pediatric cancer.” Policy 6286 was developed in response.

The policy references training approved by the chief medical officer of the State. However, we have been informed that there is no one currently with HHS in that position. Moreover, HHS does not intend to approve any training on the subject of a student returning to school after being treated for cancer. Accordingly, the reference to the chief medical officer has been stricken from the policy.

---

<sup>3</sup> Section 79-760.02.

<sup>4</sup> Section 28-311.06.

**14. Policy 6410— Title I Parental and Family Involvement ESSA**

The ESSA includes changes to parental involvement in the Title I schools. The primary impact is to expand the requirements from parents to “parents and family members.” We have revised Policy 6410 accordingly.

**15. Policy 6800—Internet Safety and Acceptable Use Policy/COPPA**

Policy 6800 provides that the district’s technology resources are not to be used for personal use. Given that many districts permit personal use if the employee has entered into a limited lease agreement with the district, we have revised the policy to allow personal use where a lease exists.

Also, COPPA requires that schools obtain verifiable parental consent before allowing third parties to access student data on-line. We have updated the internet use policy to incorporate the requirements of COPPA.

**16. Policy 6920—Student Self-Management of Asthma, Anaphylaxis, and/or Diabetes**

The statute on student self-management of asthma and anaphylaxis<sup>5</sup> requires medical authorization by the student’s physician. LB 1086 amends the physician reference to also include “other health care professional who prescribed the medication for treatment of the student's condition.”

Policy 6920 and the attendant asthma and self-management plan form have been revised to provide for authorization from other health care professionals (instead of only the student’s physician).

We note that a similar change was not made to the statute on self-management of diabetes.<sup>6</sup>

We have also included these changes made by LB 1086 on Form 6920A.

**17. Policy 8270—Conflict of Interest Procedures**

The conflict statute related to the employment of family members<sup>7</sup> requires that Nebraska Accountability and Disclosure Commission (NADC) Form C-4 be filed with the Board of Education.

---

<sup>5</sup> Section 79-224.

<sup>6</sup> Section 79-225.

<sup>7</sup> Section 49-1499.04: (1) An official or employee of a political subdivision may employ or recommend or supervise the employment of an immediate family member if (a) he or she does not abuse his or her official position as described in section 49-1499.05, (b) he or she makes a full disclosure on the record to the governing body of the political subdivision and a written disclosure to the person in charge of keeping records for the governing body, and (c) the governing body of the political subdivision approves the employment or supervisory position.

Policy 8270 had provided that the form was also to be filed with the NADC. However, the form now provides: “Disclosure need not be made to the Nebraska Accountability and Disclosure Commission.” We have revised Policy 8270 to delete the reference to filing with the NADC.

## **18. Policy 9341—Voting**

The Open Meetings Act requires that motions be made and seconded by “roll call vote of the public body in open session.”<sup>8</sup> LB 876 amended the Act to permit electronic voting, so long as the votes of the board members may be readily seen by the public.

Policy 9341 was amended to provide for the use of an electronic voting device in the event any Board of Education chooses to use that option.

## **19. ESSA Changes**

The Every Student Succeeds Act was signed on December 10, 2015. It will replace the No Child Left Behind Act of 2001. Policies that refer to the NCLB have been amended to reflect the enactment of the ESSA.

The policies affected include:

- Index – Series 3000
- Index – Series 4000
- Policy 5104—Drug Free Schools
- Index – Series 6000

In addition, the ESSA requires that a notice be posted, in a public place, to inform taxpayers how to report suspected improper use of taxpayer funds. This requirement can be met by posting the enclosed notice in a public place in your District’s building.

### **Conclusion**

If you need anything further with regard to these documents or have questions, please contact either Greg ([gperry@perrylawfirm.com](mailto:gperry@perrylawfirm.com)) or Rex ([rschultze@perrylawfirm.com](mailto:rschultze@perrylawfirm.com)).

School Districts that receive this Memo and the enclosures should consult with their school attorney for independent legal advice.

---

<sup>8</sup> Section 84-1413(2).

[SCHOOL DISTRICT]'S NOTICE OF PREVENTION OF IMPROPER USE OF TAXPAYER FUNDS

Pursuant to the Every Student Succeeds Act, 20 U.S.C. § 7933, [School District] hereby posts this display, in a public place, to encourage any taxpayer who observes, detects, or suspects improper use of taxpayer funds can easily report such improper use to:

**Office of Inspector General of the Department of Education**

**Phone: 1-800-MIS-USED**

**TABLE OF CONTENTS**

	POLICY
1. Budget Planning.....	3010
2. Fund Balance Reporting .....	3011
3. Public Review of Budget .....	3020
4. Transfer of Funds Between Categories.....	3030
5. Budget as Spending Plan – Budgeted Items .....	3040
6. Tuition Fees .....	3050
7. Materials Fees .....	3060
8. Summer School Fees.....	3070
9. Federal Funds.....	3080
10. Sales and Disposal of Books, Equipment and Supplies.....	3090
11. Leasing.....	3100
12. Short-Term Investing.....	3110
13. Depository.....	3120
Resolution	
14. Purchasing Policies .....	3130
15. Contracting for Services .....	3140
16. Paying for Goods and Services .....	3150
17. Report of Treasurer .....	3160
18. Periodic Audit .....	3170
19. System of Accounts .....	3180
20. Inventory of Equipment .....	3190
21. Monies in School Buildings.....	3200
22. Bonds .....	3210
23. Educational Service Units – Designated Representative .....	3220
24. Security .....	3230
25. Video Surveillance.....	3231
26. Risk Management and Safety Committee.....	3240
27. Trespassers.....	3250
28. Safe Driving Record Standard for Drivers.....	3410
Driver Certification Form	
Drivers – First Aid Procedures	
Emergency Evacuation Procedures – Small Vehicles	
29. Transportation .....	3520
30. Procedures – Bidding Construction Projects .....	3540
31. Rebates to School Personnel.....	3550
32. Records Management and Disposition .....	3560
33. ESSA.....	3570

## TABLE OF CONTENTS

		POLICY
A.	General Personnel Policies and Policies Applicable to All Personnel	
1.	Recruitment and Selection .....	4001
2.	Equal Opportunity Employment .....	4002
3.	Anti-discrimination, Anti-harassment and Anti-retaliation .....	4003
	Notice of Nondiscrimination.....	4003
	Complaint Form .....	4003
4.	Duty Hours of Employees.....	4004
5.	Absence of Employees.....	4005
6.	Absence From Building .....	4006
7.	Family and Medical Leave Policy .....	4007
	Family and Medical Leave Policy documents .....	4007A
8.	Adoption Leave.....	4008
9.	Drug and Substance Use and Abuse, with attached Appendix .....	4009
10.	Bloodborne Pathogen Compliance Plan .....	4011
11.	Infectious Diseases.....	4012
12.	Personnel Files .....	4013
13.	Receiving Agents, Salespersons, and Other Business Representatives .....	4014
14.	Unauthorized Purchases.....	4015
15.	Use of School Facilities and Equipment by School Employees .....	4016
16.	Activity Passes .....	4017
17.	Community Relations – Political Activity .....	4018
18.	Fair Labor Standards Act (Minimum Wage and Overtime) .....	4019
19.	Shredding Consumer Reports .....	4020
20.	Social Security Numbers.....	4021
21.	Military and Family Military Leave .....	4022
22.	Notification of Arrest, Criminal Charges, and Certificate, License or Child Abuse Complaints .....	4023
23.	Wage and Deduction Information.....	4024
24.	Professional Boundaries Between Employees and Students .....	4025
25.	Prohibition on Aiding and Abetting Sexual Abuse.....	4026
26.	Workplace Privacy Policy.....	4027
B.	Certificated Employees	
1.	Qualifications for Appointment as Teacher.....	4100
2.	Qualifications for Appointment to Administrative and Supervisory Positions .....	4101
3.	Contract.....	4110
4.	Certification .....	4111
5.	Probationary Certified Employees .....	4120
6.	Permanent Certified Employees .....	4121
7.	Assignment of Duties.....	4130
8.	Agents/Tutors.....	4131
9.	Student Teachers and Pre-Student Teachers.....	4132
10.	Substitute Teachers .....	4133

11. Professional Growth .....	4140
12. Teacher Training .....	4141
13. Evaluation of Teachers .....	4150
14. Reduction in Force Policy for Certificated Staff .....	4160
15. Leave of Absence.....	4170
16. Dual Sponsorship of Activities .....	4180
17. Standards of Ethical and Professional Performance – Certificated Staff .....	4190
C. Non-Certificated Employees	
1. Qualifications of Non-Certificated Employees.....	4200
2. "At Will" Employees .....	4201
3. Hiring/Dismissal .....	4210
4. Contract.....	4220
Classified Employee’s Employment Agreement.....	Regulation 4220A
5. Assignment and Transfer .....	4230
6. Complaint Procedure .....	4240
Complaint Form	
7. Bus Drivers .....	4250
8. Standards of Performance for Non-Certified Employees .....	4260
Form for Classified Employee Notice of Performance Concerns	

## TABLE OF CONTENTS

	POLICY
1. General Policy Statement.....	6000
2. Scope of Instructional Program .....	6010
3. The Program of Instruction.....	6020
4. School Instructional Hours .....	6110
5. School Day for Students .....	6112
6. Emergencies .....	6114
7. Fire Drills, Emergency Plans .....	6115
8. Emergency Dismissal or Cancellation .....	6116
9. Ceremonies, Observances, and the Pledge of Allegiance.....	6117
10. Safe Schools Policy.....	6120
11. Curriculum Review Cycle.....	6121
12. Objectives of the Instructional Program .....	6200
13. Curriculum - Development and Adoption .....	6210
14. Curriculum - Assessments .....	6211
15. Assessments—Academic Content Standards – Adopt State Standards.....	6212
16. Experimental/Innovative Program .....	6220
17. Curriculum Guides.....	6230
18. Homework.....	6240
19. Purpose of Homework .....	6241
20. Guidance .....	6260
21. Field Trips.....	6270
22. Activities.....	6280
23. Activity Funds Management.....	6281
24. School Colors.....	6282
25. Concussions .....	6283
Return to Learn Protocol.....	6283A
NDE Bridging the Gap February 2014 .....	6283B
NDE Bridging the Gap Appendix February 2014 .....	6283C
26. Initiations, Hazing, Secret Clubs and Outside Organizations.....	6284
27. Student Participation in Athletic Contests Between Schools .....	6285
28. Return to Learn After Cancer .....	6286
29. Dedications and Commencement .....	6290
30. Selection and Review of Instructional and Media Materials .....	6300
31. Textbook Loans .....	6310
32. Parent Requests for Exclusion .....	6320
33. Recognition of Religious Beliefs and Customs .....	6360
34. Acknowledgment of Religious Holidays .....	6361
35. Religion in the Curriculum .....	6362
36. Purpose of Religion in the Curriculum .....	6363
37. Multicultural Education .....	6370
38. Equal Opportunity: Instruction Program .....	6380
39. Controversial Issues .....	6390
40. Controversial Issues in the Classroom.....	6391
41. Parental/Community Involvement in Schools .....	6400
42. Title I Parental and Family Involvement .....	6410
43. Free and Reduced Price Meals.....	6500

44. Special Education Policies and Regulations .....6600

45. Firearm Policy.....6700

46. Computer—Internet Safety and Acceptable Use Policy.....6800

47. Chronic Infectious Disease Practice and Procedure .....6900

48. Dispensing Medications.....6910

49. Student Self-Management of Asthma, Anaphylaxis, and/or Diabetes .....6920

Asthma or Anaphylaxis Medical Management Plan

Diabetes Medical Management Plan

From: **Stahr, Steven 1155** Stahr.Steven@den.sysco.com  
Subject: dishwasher  
Date: May 17, 2016 at 8:49 PM  
To: Joey Lefdal jlefdal@ccschools.cc



Not sure which item to pick? Let us help. Our experts are here to answer any question you may have.  Call 800-779-8441 For free advice and fast answers to all your questions

Home » Equipment » Warewashing » Dishwashers » Conveyor Dishmachine

## Jackson® CREW-44CE Electric Dishwasher Hi Temp 44"

Jackson | Free Shipping via Common Carrier/Freight | Usually ships within 7 to 14 business days



 View Larger Image

Product Description | Product Specification | Specification Docs

**Product ID:** JDM-CREW44CE | **Mfg Part No.** CREW-44CE

- Conveyor® type
- High temperature sanitizing
- Single tank design
- Adjustable conveyor speed
- Cleans 218 racks per hour
- 19-3/4" clearance through machine
- Stainless steel construction
- Electric tank heat
- Vent fan control
- Vent cowl collar
- 19-3/4" (502 mm) clearance
- WISR® Cleaning System
- Double-wall insulated door retains heat
- Self-cleaning wash arms
- Fully automatic including auto...

 [Click here to Request the Lowest Price](#)

RETAIL PRICE:  
**\$15,008.18**

1 [Add to Cart](#) 

[Leasing options available »](#)

[Add to Order Guide](#) 

Joey I called and got a price of \$14545.55 and free shipping.

From: Nick Flynn nick@crouchrec.com  
Subject: FW: Chase County Schools Quote  
Date: June 20, 2016 at 10:15 AM  
To: Joey Lefdal jlefdal@chasecountyschools.org



Joey,

Attached is the quotes for the swings and ten spin. I also provided you with a top view with the swings to show you the area you will need, which is in the lower left corner. You will have plenty of space for the swings and the ten spin. I did not include installation because when we talked you had mentioned that you might possibly do the install yourselves. Any questions please call me or shoot me an email anytime. I look forward to golfing with you tomorrow in Valentine.

Thanks,

Nick Flynn



[www.crouchrec.com](http://www.crouchrec.com)

Cell: (402) 201-6092

Office: (402) 496-2669

Fax: (402) 496-2018

Visit us on [Facebook](#)

---

Chase County Schools  
Imperial, NE

101

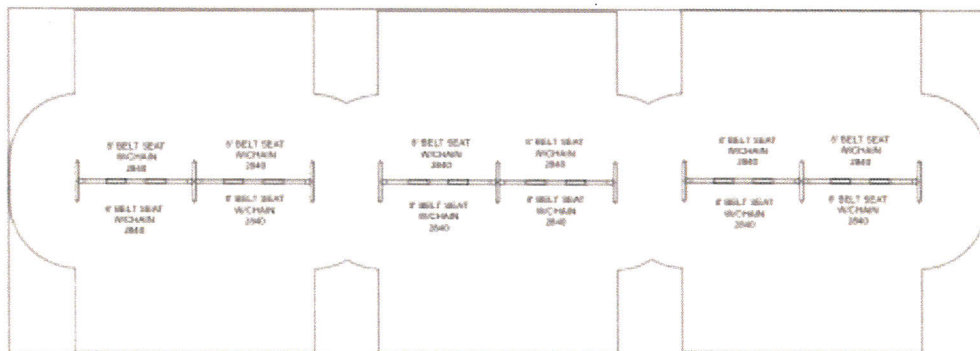



<b>DUCH RECREATION</b>		<b>11_42541444139</b>		To promote safe and proper equipment use by children, Miracle recommends the installation of either a Miracle safety sign or other appropriate safety signage near each play system's main entry point(s) to inform parents and supervisors of the age appropriateness of the play system and general rules for safe play.	THE PLAY COMPONENTS IDENTIFIED IN THIS PLAN ARE IPEMA CERTIFIED. THE USE AND LAYOUT OF THESE COMPONENTS CONFORM TO THE REQUIREMENTS OF ASTM F1487  AN ENERGY ABSORBING PROTECTIVE SURFACE IS REQUIRED UNDER & AROUND ALL PLAY SYSTEMS
5150th Circle S.E.		✓ <b>COMPLIES TO ASTM/CPS</b>			
PHONE NO: (402) 496-2669 FAX NO: (402) 496-2670					
40 SPACE: 79'-0" x 4'-0" ACTIVE AREA: 32'-0" x 32'-0" BY: Eric Grouth      DATE: 6/20/21					

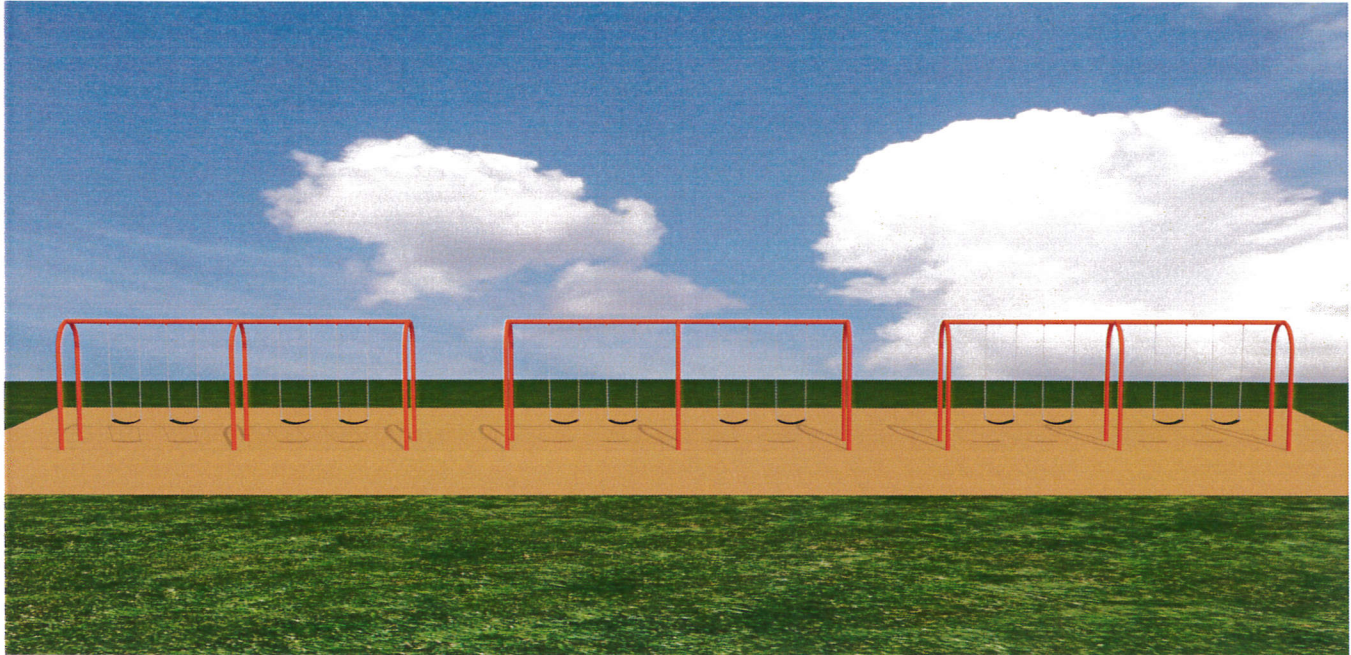

20160620110846.pdf



**Sales Representative**  
 Crouch Recreational Design, Inc.  
 2435 S 156th Circle  
 Omaha, NE 68130  
 Phone: (800) 747-7528 Fax: (402) 496-2018

## Equipment Quotation

**Quote Number:** 11160265  
**Quote Date:** 06/20/2016  
**Customer Number**  
**Terms of Sale:** Net 30  
**Customer Class:** 2. Schools  
**Shipping Method:** Best Way  
**Freight Terms:** Prepaid  
**Approximate Ship Date:** ASAP  
**Cust PO Num:**

**PO Remittance (if other than Sales Representative):**

**Prepared For:** CHASE COUNTY SCHOOLS  
 520 E 9TH STREET  
 IMPERIAL, NE 69033

**Location:** CHASE COUNTY SCHOOLS  
 520 E 9TH STREET  
 IMPERIAL, NE 69033

**Payment Remittance:** Miracle Recreation Equipment Company  
 PO Box 204757, Dallas, TX 75320-4757

**Shipping/Delivery Contact:** JOEY LEFDAL (308) 882-4304

**Payment/Accounting Contact:** JOEY LEFDAL (308) 882-4304

Quantity	Item Number	Description	Price Each	Price Total
3	7188524SJ	3 1/2" OD ARCH FRAME W/4 SLPRF SEATS MC	\$1,780.00	\$5,340.00
1	304J	TEN SPIN	\$2,480.00	\$2,480.00
<b>Color List:</b>			<b>Equipment Total:</b>	\$7,820.00
System: SWJ Item Number: 7188524SJ Quantity: 3			<b>Freight:</b>	\$0.00
System: WHJ Item Number: 304J Quantity: 1			<b>SubTotal:</b>	\$7,820.00
			<b>Tax:</b>	\$0.00
			<b>Grand Total:</b>	\$7,820.00

This Quote shall not become a binding contract until signed and delivered by both Customer and Miracle Recreation Equipment Company ("Miracle"). Sales Representative is not authorized to sign this Quote on behalf of Miracle or Customer, and signed Quotes cannot be accepted from Sales Representative. To submit this offer, please sign below and forward a complete signed copy of this Quote directly to "Miracle Sales Administration" via fax (417) 235-3551 or email: orders@miraclerec.com. Upon acceptance, Miracle will return a fully-signed copy of the Quote to Customer (with copy to Sales Representative) via fax or email.

THIS QUOTE IS LIMITED TO AND GOVERNED BY THE TERMS CONTAINED HEREIN. Miracle objects to any other terms proposed by Customer, in writing or otherwise, as material alterations, and all such proposed terms shall be void. Customer authorizes Miracle to ship the Equipment and agrees to pay Miracle the total amount specified. Shipping terms are FOB the place of shipment via common carrier designated by Miracle. Payment terms are Net-30 days from invoice date with approved credit and all charges are due and payable in full at PO Box 204757, Dallas, TX 75320-4757, unless notified otherwise by Miracle in writing. Customer agrees to pay all additional service charges for past due invoices. Customer must provide proper tax exemption certificates to Miracle, and shall promptly pay and discharge all otherwise applicable taxes, license fees, levies and other impositions on the Equipment at its own expense. Purchase orders and payments should be made to the order of Miracle Recreation Equipment Company.

**Quote Number:** 11160265      **Quote Date:** 06/20/2016      **Equipment Total:** \$7,820.00      **Grand Total:** \$7,820.00

CUSTOMER HEREBY SUBMITS ITS OFFER TO PURCHASE THE EQUIPMENT ACCORDING TO THE TERMS STATED IN THIS QUOTE AND SUBJECT TO FINAL APPROVAL BY MIRACLE.

**Submitted By**

**Printed Name and Title**

**Date**

THE FOREGOING QUOTE AND OFFER ARE HEREBY APPROVED AND ACCEPTED BY MIRACLE RECREATION EQUIPMENT COMPANY.

**By:** \_\_\_\_\_

**Date:** \_\_\_\_\_

**ADDITIONAL TERMS CONDITIONS OF SALE**

1. Use & Maintenance. Customer agrees to regularly inspect and maintain the Equipment, and to provide, inspect and maintain appropriate safety surfacing under and around the Equipment, in accordance with Miracle's product literature and the most current Consumer Product Safety Commission Handbook for Public Playground Safety.

2. Default, Remedies & Delinquency Charges. Customer's failure to pay any invoice when due, or its failure to otherwise comply with the terms of this Quote, shall constitute a default under all unsatisfied invoices ("Event of Default"). Upon an Event of Default, Miracle shall have all remedies available to it at law or equity, including, without limitation, all remedies afforded a secured creditor under the Uniform Commercial Code. Customer agrees to assist and cooperate with Miracle to accomplish its filing and enforcement of mechanic's or other liens with respect to the Equipment or its location or its repossession of the Equipment, and Customer expressly waives all rights to possess the Equipment after an Event of Default. All remedies are cumulative and not alternative, and no exercise by Miracle of a remedy will prohibit or waive the exercise of any other remedy. Customer shall pay all reasonable attorneys' fees plus any costs of collection incurred by Miracle in enforcing its rights hereunder. Subject to any limitations under law, Customer shall pay to Miracle as liquidated damages, and not as a penalty, an amount equal to 1.5% per month of any payment that is delinquent in such month and is not received by Miracle within ten (10) days after the date on which due.

3. Limitation of Warranty/ Indemnity. MIRACLE MAKES NO EQUIPMENT WARRANTIES EXCEPT FOR THOSE STANDARD WARRANTIES ISSUED WITH THE EQUIPMENT, WHICH ARE INCORPORATED HEREIN BY THIS REFERENCE. MIRACLE SPECIFICALLY DISCLAIMS ANY IMPLIED WARRANTY OF MERCHANTABILITY OR FITNESS FOR A PARTICULAR PURPOSE AND ANY LIABILITY FOR INCIDENTAL OR CONSEQUENTIAL DAMAGES. CUSTOMER AGREES TO DEFEND, INDEMNIFY AND SAVE MIRACLE HARMLESS FROM ALL CLAIMS OF ANY KIND FOR DAMAGES OF ANY KIND ARISING OUT OF CUSTOMER'S ALTERATION OF THE EQUIPMENT, ITS FAILURE TO MAINTAIN THE EQUIPMENT, ITS FAILURE TO PROPERLY SUPERVISE EQUIPMENT USE, OR ITS FAILURE TO PROVIDE AND MAINTAIN APPROPRIATE TYPES AND DEPTHS OF SAFETY SURFACING BENEATH AND AROUND THE EQUIPMENT IN ACCORDANCE WITH MIRACLE'S INSTALLATION AND OWNER'S MANUALS AND THE MOST CURRENT CONSUMER PRODUCT SAFETY COMMISSION HANDBOOK FOR PUBLIC PLAYGROUND SAFETY.

4. Restrictions. Until all amounts due hereunder are paid in full, Customer shall not: (i) permit the Equipment to be levied upon or attached under any legal process; (ii) transfer title to the Equipment or any of Customer's rights therein; or (iii) remove or permit the removal of the Equipment to any location not specified in this Quote.

5. Purchase Money Security Interest. Customer hereby grants, pledges and assigns to Miracle, and Miracle hereby reserves a purchase money security interest in, the Equipment in order to secure the payment and performance in full of all of Customer's obligations hereunder. Customer agrees that Miracle may file one or more financing statements, in order to allow it to perfect, acquire and maintain a superior security interest in the Equipment.

6. Choice of Law and Jurisdiction. All agreements between Customer and Miracle shall be interpreted, and the parties' obligations shall be governed, by the laws of the State of Missouri without reference to its choice of law provisions. Customer hereby consents to the personal jurisdiction of the state and federal courts located in the city and county of St. Louis, Missouri.

7. Title; Risk of Loss; Insurance. Miracle Retains full title to all Equipment until full payment is received by Miracle. Customer assumes all risk of loss or destruction of or damage to the Equipment by reason of theft, fire, water, or any other cause, and the occurrence of any such casualty shall not relieve the Customer from its obligations hereunder and under any invoices. Until all amounts due hereunder are paid in full, Customer shall insure the Equipment against all such losses and casualties.

8. Waiver; Invalidity. Miracle may waive a default hereunder, or under any invoice or other agreement between Customer and Miracle, or cure such a default at Customer's expense, but shall have no obligation to do either. No waiver shall be deemed to have taken place unless it is in writing, signed by Miracle. Any one waiver shall not constitute a waiver of other defaults or the same kind of default at another time, or a forfeiture of any rights provided to Miracle hereunder or under any invoice. The invalidity of any portion of this Quote shall not affect the force and effect of the remaining valid portions hereof.

9. Entire Agreement; Amendment; Binding Nature. This fully-executed Quote, as supplemented by Change Orders and invoices containing exact amounts of estimates provided herein, constitutes the complete and exclusive agreement between the parties. A Change Order is a written instrument signed by the Customer and Miracle stating their agreement as to any amendment in the terms of this Quote. Customer acknowledges that Change Orders may result in delays and additional costs. The parties agree that all Change Orders shall include appropriate adjustments in price and time frames relating to any requested amendments. Upon full execution, this Quote shall be binding upon and inure to the benefit of the parties and their successors and assigns.

10. Counterparts; Electronic Transmission. This Quote, any invoice, and any other agreement between the parties, may be executed in counterparts, each of which shall constitute an original. The facsimile or other electronic transmission of any signed original document, and retransmission of any signed facsimile or other electronic transmission, shall be the same as the transmission of an original. At the request of either party, the parties will confirm facsimile or other electronically transmitted signatures by signing an original document.

# CHASE COUNTY SCHOOL - GYM ADDITION

520 EAST 9TH STREET, IMPERIAL, NEBRASKA 69033

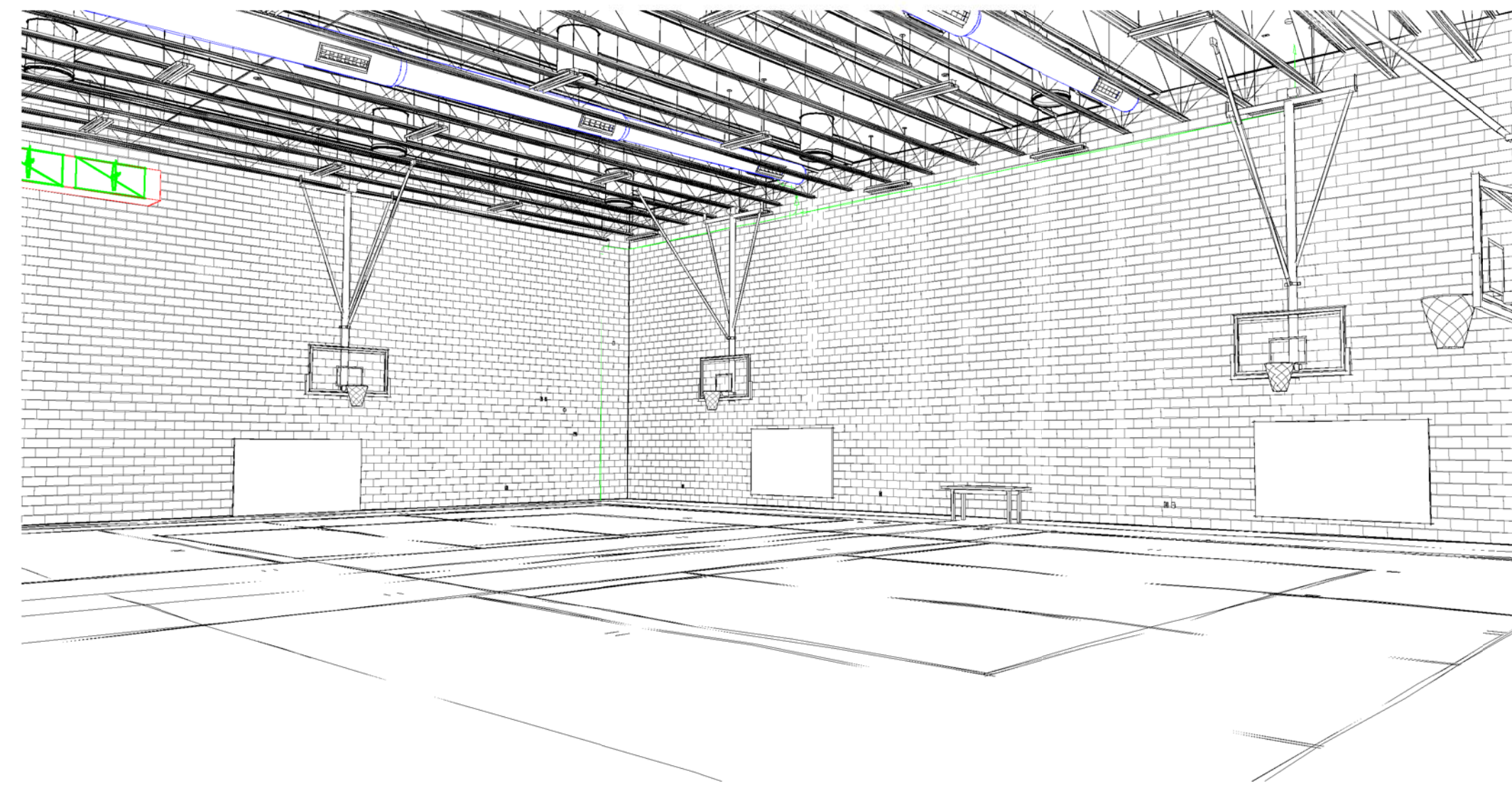

INTERIOR PERSPECTIVE - GYM

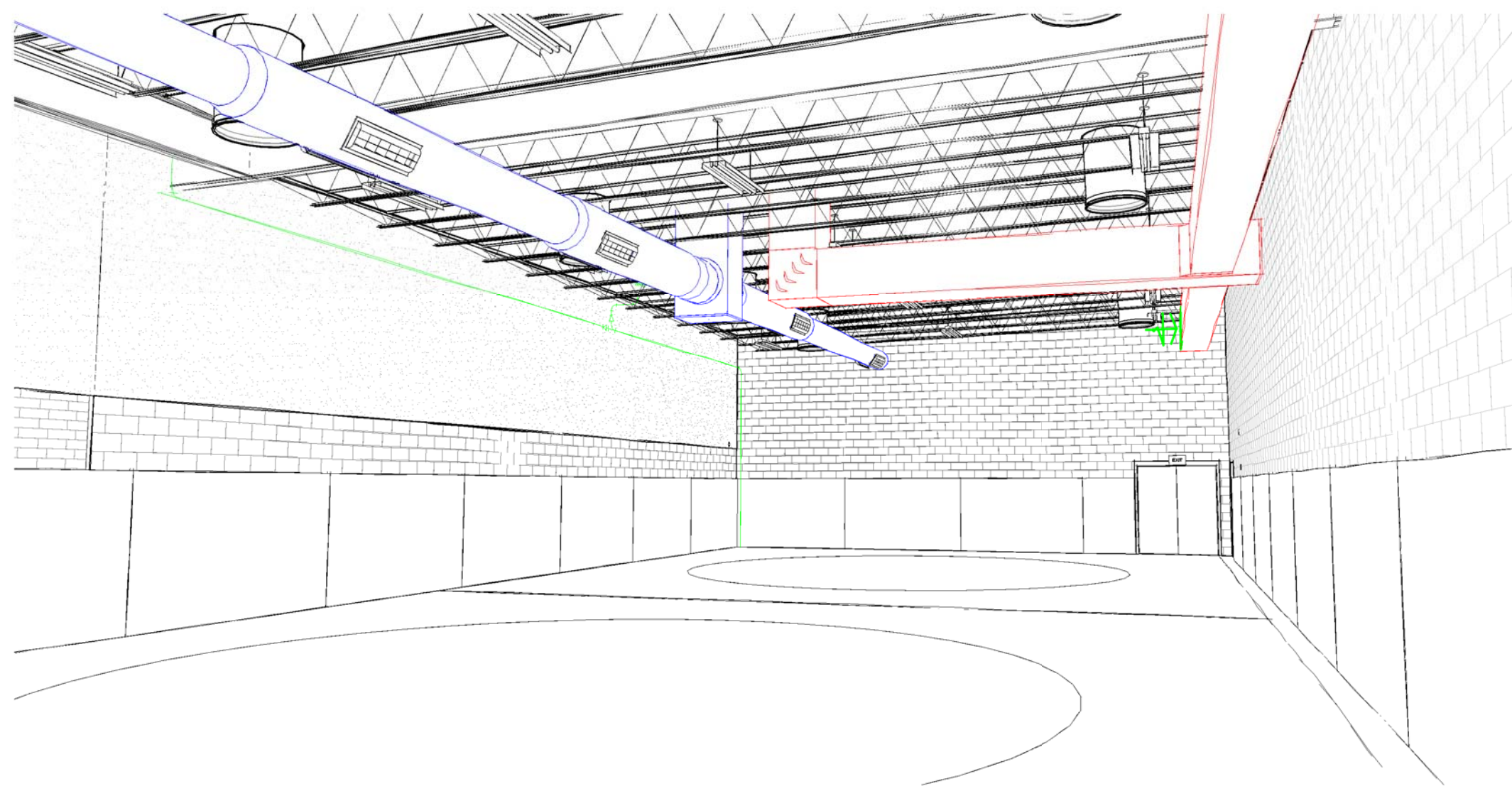

INTERIOR PERSPECTIVE - WRESTLING

## PROJECT PICTURE



PROJECT LOCATION  
520 E 9th St, Imperial, NE 69033

VICINITY MAP

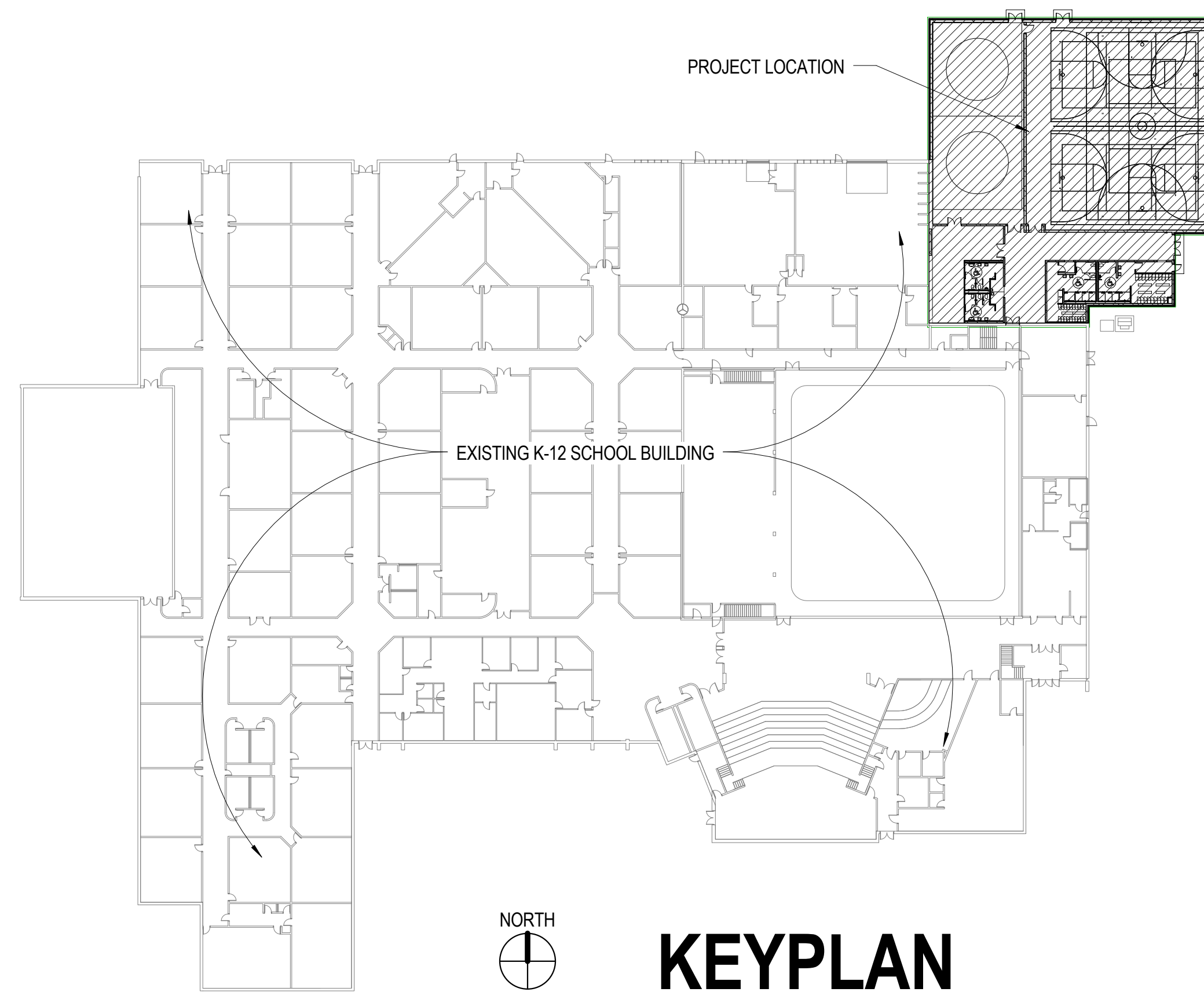

KEYPLAN

## PROJECT CONTACTS

### OWNER

Chase County Schools  
Joey Jelfal  
P.O. Box 577  
Imperial, NE 69033  
jelfal@chasecountyschools.org

### CIVIL

Baker & Associates  
Barry Swanson  
120 East 16th Street  
Scottsbluff, Nebraska, 69361  
Phone: (308) 632-3123  
bswanson@baker-eng.com

### ARCHITECTURAL

Studio 120 Architecture  
Jamie Winters, AIA, NCARB  
120 East 16th Street  
Scottsbluff, Nebraska, 69361  
Phone: (308) 635-1531  
jamie@studio120arch.com

### STRUCTURAL

Studio 120 Architecture  
Stephen Klass, P.E., S.E.  
120 East 16th Street  
Scottsbluff, Nebraska, 69361  
Phone: (308) 635-1531  
stephen@studio120arch.com

### MECHANICAL

Specialized Engineering Solutions  
Ben Schmitt, P.E.  
1205 Jackson Street, Suite 204,  
Sidney, NE 69162  
308.203.1201  
bschmitt@specializedeng.com

### PLUMBING

Specialized Engineering Solutions  
Ben Schmitt, P.E.  
1205 Jackson Street, Suite 204,  
Sidney, NE 69162  
308.203.1201  
bschmitt@specializedeng.com

### ELECTRICAL

Specialized Engineering Solutions  
Jeremy Klima  
333 East 2nd Street, Suite 16  
Ogallala, NE  
(308) 284-7323  
jklima@specializedeng.com

### ONE CALL

Nebraska Contact  
Phone: 1-800-331-5666  
www.ne-diggers.com

### Drawing Sheet Index - General

Sheet Number	Sheet Title
0	COVER SHEET

Total Number of Sheets: 1

### Drawing Sheet Index - Civil

Sheet Number	Sheet Title
C-0.01	CIVIL NOTES, ABBREVIATIONS, SYMBOLS & LINETYPES
C-1.00	EXISTING SITE PLAN
C-1.01	DEMOLITION SITE PLAN
C-2.00	PROPOSED SITE PLAN
C-5.00	SANITARY SEWER SERVICE STATION 100-00 TO STATION 103+46
C-5.01	SANITARY SEWER SERVICE STATION 103+46 TO STATION 106+81
C-7.00	DETAILS

Total Number of Sheets: 7

### Drawing Sheet Index - Structural

Sheet Number	Sheet Title
S-0.01	STRUCTURAL NOTES
S-0.02	STRUCTURAL NOTES
S-0.03	STRUCTURAL NOTES
S-1.00	GROUND LEVEL FOUNDATION PLAN
S-1.10	OVERALL ROOF FRAMING PLAN
S-3.00	TYPICAL CONCRETE DETAILS
S-3.01	TYPICAL CONCRETE DETAILS
S-3.10	TYPICAL SPREAD FOOTING DETAILS
S-3.11	TYPICAL SPREAD FOOTING DETAILS
S-3.12	TYPICAL SLAB-ON-GRADE DETAILS
S-3.13	TYPICAL SLAB-ON-GRADE DETAILS
S-3.14	TYPICAL SLAB-ON-GRADE DETAILS
S-4.00	TYPICAL STRUCTURAL MASONRY DETAILS
S-4.01	TYPICAL STRUCTURAL MASONRY DETAILS
S-4.02	TYPICAL STRUCTURAL MASONRY DETAILS
S-4.03	TYPICAL STRUCTURAL MASONRY DETAILS
S-5.00	TYPICAL STEEL TO CONCRETE CONNECTIONS
S-5.11	TYPICAL STEEL BEAM FRAMING DETAILS
S-5.20	TYPICAL STEEL JOIST DETAILS
S-5.33	TYPICAL METAL DECK DETAILS
S-5.34	TYPICAL METAL DECK OPENING DETAILS

Total Number of Sheets: 21

### Drawing Sheet Index - Architectural

Sheet Number	Sheet Title
A-0.01	ARCHITECTURAL NOTES, CODE SUMMARY AND SYMBOL LEGEND
A-0.10	GROUND LEVEL DEMOLITION
A-1.00	GROUND LEVEL PLAN
A-1.10	ROOF PLAN
A-2.00	GROUND LEVEL REFLECTED CEILING PLAN
A-3.10	EXTERIOR BUILDING ELEVATIONS
A-3.11	EXTERIOR BUILDING ELEVATIONS
A-3.20	BUILDING SECTIONS
A-3.21	BUILDING SECTIONS
A-3.22	BUILDING SECTIONS
A-4.10	WALL SECTIONS
A-4.11	WALL SECTIONS
A-4.12	ROOF & EXPANSION JOINT DETAILS
A-4.20	AIR & WEATHER BARRIER DETAILS
A-5.00	ENLARGED PLANS
A-7.00	DOOR AND WINDOW SCHEDULES
A-8.00	INTERIOR ELEVATIONS
A-8.01	INTERIOR ELEVATIONS
A-8.02	INTERIOR ELEVATIONS
A-8.03	INTERIOR ELEVATIONS
A-8.04	INTERIOR ELEVATIONS
A-10.00	FINISH PLAN & SCHEDULES

Total Number of Sheets: 22

### Drawing Sheet Index - Mechanical

Sheet Number	Sheet Title
M-0.00	MECHANICAL SYMBOLS
M-0.10	GROUND LEVEL - MECHANICAL DEMOLITION
M-1.10	GROUND LEVEL - HVAC
M-1.20	MECHANICAL ROOF PLAN
M-2.00	GROUND LEVEL - UNDERFLOOR PLUMBING
M-2.10	GROUND LEVEL - PLUMBING
M-3.10	GROUND LEVEL - FIRE PROTECTION
M-4.00	MECHANICAL SECTIONS
M-4.01	MECHANICAL DETAILS
M-4.02	MECHANICAL ISOMETRICS
M-5.00	MECHANICAL DETAILS & SCHEDULES

Total Number of Sheets: 11

### Drawing Sheet Index - Electrical

Sheet Number	Sheet Title
E-0.00	GROUND LEVEL - ELECTRICAL DEMOLITION PLAN
E-1.10	GROUND LEVEL - LIGHTING PLAN
E-2.10	GROUND LEVEL - POWER PLAN
E-2.20	ROOF LEVEL - POWER PLAN
E-3.00	ELECTRICAL SCHEDULES
E-3.01	ELECTRICAL DETAILS
E-4.00	ELECTRICAL SYMBOLS

Total Number of Sheets: 7

### ARCHITECTURAL GENERAL NOTES

THE FOLLOWING GENERAL NOTES APPLY TO THE ARCHITECTURAL DRAWINGS:

- ALL PARTS OF THE WORK, INCLUDING MATERIALS, METHODS AND ASSEMBLIES, MUST COMPLY WITH THE MINIMUM REQUIREMENTS OF THE GOVERNING REGULATIONS OF ALL FEDERAL, STATE, DISTRICT AND LOCAL AUTHORITIES HAVING JURISDICTION OVER THE PROJECT AS WELL AS THOSE GREATER REQUIREMENTS INDICATED BY THE CONTRACT DOCUMENTS. NO PART OF THE CONTRACT DOCUMENTS MAY BE CONSTRUED TO REQUIRE WORK CONTRARY TO GOVERNING REGULATIONS.
- THE ARCHITECTURAL DRAWINGS ARE A PORTION OF THE SET OF DRAWINGS WHICH, WHEN COMPLETE, CONSIST OF ALL DISCIPLINES LISTED BY THE OVERALL DRAWING INDEX. THE WORK DESCRIBED BY THE DRAWINGS ON ANY ONE DISCIPLINE MAY BE AFFECTED BY THE WORK DESCRIBED OF ANOTHER DISCIPLINE AND MAY REQUIRE REFERENCE TO THE DRAWINGS OF ANOTHER DISCIPLINE. PARTIAL SETS OF DRAWINGS ARE INCOMPLETE AND SHOULD NOT BE DISTRIBUTED OR UTILIZED BY THE CONTRACTOR. IT IS THE CONTRACTOR'S RESPONSIBILITY TO REVIEW AND COORDINATE THE WORK OF ALL SUB-CONTRACTORS, TRADES AND/OR SUPPLIERS WITH THE REQUIREMENTS OF THE CONTRACT DOCUMENTS BEFORE COMMENCING CONSTRUCTION AND TO ASSURE THAT ALL PARTIES ARE AWARE OF ALL REQUIREMENTS, REGARDLESS OF WHERE THE REQUIREMENTS OCCUR IN THE CONTRACT DOCUMENTS, WHICH MIGHT AFFECT THE WORK OF THAT PARTY.
- AS PART OF THE CONTRACTOR'S RESPONSIBILITY TO COORDINATE THE WORK OF ALL SUB-CONTRACTORS, TRADES AND/OR SUPPLIERS, THE CONTRACTOR SHALL ENDEAVOR TO IDENTIFY AND NOTIFY THE ARCHITECT OF ANY CONFLICTS BETWEEN THE WORK OF DIFFERENT PARTIES AT THE EARLIEST POSSIBLE DATE SO AS TO ALLOW ADEQUATE TIME FOR THE CONFLICT TO BE RESOLVED WITHOUT DELAYING THE WORK. ALL DEVIATIONS FROM THAT WHICH IS REQUIRED BY THE CONTRACT DOCUMENTS MUST BE APPROVED IN ADVANCE BY THE ARCHITECT.
- IT IS THE INTENT OF THE ARCHITECTURAL DRAWINGS TO ESTABLISH AND COORDINATE THE FINISHED APPEARANCE AND EXACT LOCATION OF ALL EXPOSED WORK OF ALL TRADES, INCLUDING THAT WORK WHICH IS ILLUSTRATED PRIMARILY ON DRAWINGS OF OTHER DISCIPLINES. LOCATIONS SHOWN ON OTHER DISCIPLINE'S DRAWINGS ARE SCHEMATIC UNLESS NOTED OTHERWISE. THE ARCHITECTURAL DRAWINGS TAKE PRECEDENCE FOR THE FINISHED APPEARANCE AND EXACT LOCATION AT ALL TIMES.
- DO NOT SCALE DRAWINGS.
- WHERE DISCREPANCIES OCCUR BETWEEN PLANS, DETAILS, NOTES AND SPECIFICATIONS, THE MORE STRINGENT REQUIREMENTS SHALL GOVERN. DETAILS ON DRAWINGS TAKE PRECEDENCE OVER NOTES AND TYPICAL DETAILS. DETAILS NOTED AS TYPICAL APPLY TO ALL SIMILAR CONDITIONS. WHERE NO SPECIFIC DETAILS ARE SHOWN, CONSTRUCTION SHALL CONFORM TO SIMILAR WORK ELSEWHERE ON THE PROJECT.
- THE ARCHITECTURAL FLOOR PLANS, REFLECTED CEILING PLANS, SECTIONS AND ELEVATIONS ILLUSTRATE THE EXACT LOCATION OF MANY, BUT NOT ALL EXPOSED PARTS OF THE WORK. APPLY THE FOLLOWING RULES IN ORDER, TO DETERMINE THE EXACT LOCATION OF EACH EXPOSED PART OF THE WORK:
  - REFER TO THE SPECIFIC APPLICABLE LARGE-SCALE ARCHITECTURAL PLANS, SECTIONS, ELEVATIONS OR DETAILS. LOCATE AS DIMENSIONED.
  - IF NOT SHOWN OR UNIQUELY DIMENSIONED, REFER TO THE APPLICABLE TYPICAL ARCHITECTURAL MOUNTING HEIGHT AND/OR CONFIGURATION DETAILS. LOCATE AS INDICATED BY THE APPLICABLE DETAIL OR RULE.
  - IF NOT SHOWN OR DIMENSIONED ON TYPICAL ARCHITECTURAL DETAILS, LOCATE AS DIMENSIONED BY THE DRAWINGS OF OTHER DISCIPLINES.
  - IF NOT SHOWN OR DIMENSIONED ON DRAWINGS OF OTHER DISCIPLINES, PLACE AT THE APPROXIMATE LOCATION SHOWN BY THE DRAWINGS OF OTHER DISCIPLINES.
- STUDIO 120 ARCHITECTURE CONSIDERS THAT PLANS AND SPECIFICATIONS ARE APPROVED DOCUMENTS ONLY IF:
  - THE DOCUMENTS ARE PAPER COPIES WITH SIGNATURES AND PROFESSIONAL CERTIFICATION VISIBLY PRESENT ON THE PAPER COPIES OR
  - ELECTRONIC FILES IN ADOBE® PORTABLE DOCUMENT FILE (PDF) FORMAT ISSUED DIRECTLY BY STUDIO 120 ARCHITECTURE (HEREINAFTER REFERRED TO AS ELECTRONICALLY TRANSMITTED DATA).

INFORMATION SUPPLIED VIA METHODS OTHER THAN THOSE NOTED ABOVE ARE NOT TO BE CONSIDERED APPROVED DOCUMENTS. THE RECEIVER OF ELECTRONICALLY TRANSMITTED DOCUMENTS IS RESPONSIBLE FOR VERIFYING THE INFORMATION PROVIDED IS AN APPROVED DOCUMENT. THE USE OF ELECTRONICALLY TRANSMITTED DRAWINGS IS CONSIDERED TO BE AT THE USER'S RISK. STUDIO 120 ARCHITECTURE ASSUMES NO RESPONSIBILITY FOR ANY CLAIMS OR DAMAGES RESULTING FROM USE OF THIS ELECTRONIC INFORMATION. ELECTRONIC INFORMATION IS PROVIDED FOR THE CONVENIENCE OF THE RECIPIENT ONLY. THE ELECTRONIC INFORMATION IS COPYRIGHTED AND MAY NOT BE TRANSFERRED TO ANY OTHER PARTY WITHOUT THE PERMISSION OF STUDIO 120 ARCHITECTURE. PLEASE REFERENCE THE REQUIREMENTS OF DOCUMENT 00800, ELECTRONIC DATA.
- REASONABLE EFFORT HAS BEEN MADE BY THE ENGINEER TO INDICATE THE TYPE, SIZE, LOCATION, AND NUMBER OF KNOWN UNDERGROUND FACILITIES ON THE DRAWING(S). HOWEVER, NO GUARANTEE IS MADE AS TO THE TRUE TYPE, SIZE, LOCATION, OR NUMBER OF SUCH FACILITIES. THE OMISSION FROM OR THE INCLUSION OF UTILITY LOCATIONS ON THE DRAWING(S) IS NOT TO BE CONSIDERED AS THE NON-EXISTENCE OF OR AN ABSOLUTE LOCATION OF, EXISTING UNDERGROUND UTILITIES. THE CONTRACTOR SHALL MEET ALL THE REQUIREMENTS OF THE NEBRASKA ONE-CALL NOTIFICATION ACT (STATE OF NEBRASKA TITLE 155, CHAPTER 2).

### ARCHITECTURAL SUPPLEMENTAL NOTES

- ALL NEW CONSTRUCTION IS TO CONFORM TO LOCAL, STATE AND NATIONAL BUILDING AND SAFETY GOVERNING AGENCIES. THE FOLLOWING DRAWINGS ARE SUBJECT TO ANY CHANGES THAT MAY BE REQUIRED BY LOCAL, STATE AND NATIONAL GOVERNING AGENCIES.
- GENERAL CONTRACTOR IS RESPONSIBLE FOR TOTAL FAMILIARITY WITH EXISTING CONDITIONS. ALL QUESTIONS AND DISCREPANCIES SHALL BE BROUGHT TO THE ATTENTION OF THE OWNER/ARCHITECT PRIOR TO SUBMITTAL OF BID TO BUILDING REPRESENTATIVE.
- CONTRACTOR IS TO COORDINATE BETWEEN ARCHITECTURAL, STRUCTURAL, MECHANICAL, PLUMBING, FIRE PROTECTION AND ELECTRICAL DRAWINGS ALONG WITH THE DESIGNATED SUB-CONTRACTORS FOR ALL OF THE TRADES.
- ALL NEW CONSTRUCTION DETAILS, FINISHES, TEXTURES, ETC., ARE TO BE INSTALLED PER MANUFACTURER'S RECOMMENDATIONS OR BUILDING INDUSTRY STANDARDS UNLESS OTHERWISE NOTED.
- THE CONTRACTOR IS TO COORDINATE WITH OWNER'S VENDORS ON SCHEDULING REQUIREMENTS AND INSTALLATION OF ITEMS BEING SUPPLIED AND INSTALLED BY THEM IF THEY ARE NOT A PART OF THE CONSTRUCTION CONTRACT.
- ALL THE FIRE PROTECTION AND LIFE SAFETY SYSTEMS ARE TO BE PROVIDED AS REQUIRED PER THE CODE REQUIREMENTS, VERIFY WITH THE BUILDING DEPARTMENT AND FIRE DEPARTMENT. INCLUDE ADDITIONAL SMOKE DETECTORS AND INDICATOR LIGHTS AS REQUIRED AND TYING INTO THE FIRE PROTECTION SYSTEM.
- ALL NEW CONSTRUCTION IS TO ADHERE TO A.D.A. REQUIREMENTS UNLESS OTHERWISE DIRECTED BY THE OWNER, SUCH AS LATCH SETS, MOUNTING HEIGHTS, CLEARANCES, SLOPES, GRADES, ETC.
- THE FLOOR SLAB IS TO BE POURED AFTER ALL EQUIPMENT CONDUNIT, PLUMBING, POWER, ETC. HAVE BEEN ROUGHED IN.
- PROVIDE TYPE "X" 5/8" GYPSUM BOARD THROUGHOUT NEW CONSTRUCTION UNLESS OTHERWISE NOTED.
- PROVIDE RATED WALLS AS REQUIRED FOR NEW CONSTRUCTION. THIS INCLUDES WALLS, CEILINGS, DUCTWORK, DOORS, FRAMES, HARDWARE, ETC.
- ALL INTERIOR COLORS, TEXTURES AND FINISHES ARE TO BE SELECTED BY THE OWNER/ARCHITECT.
- ANY NOTES MENTIONED ON THIS SHEET OR ON ANY OTHER SHEET SHALL PERTAIN TO ALL SHEETS.
- ALL WORK AND DRAWINGS ARE TO BE REVIEWED AND APPROVED BY THE OWNER PRIOR TO CONSTRUCTION.

### ARCHITECTURAL WALL TYPES

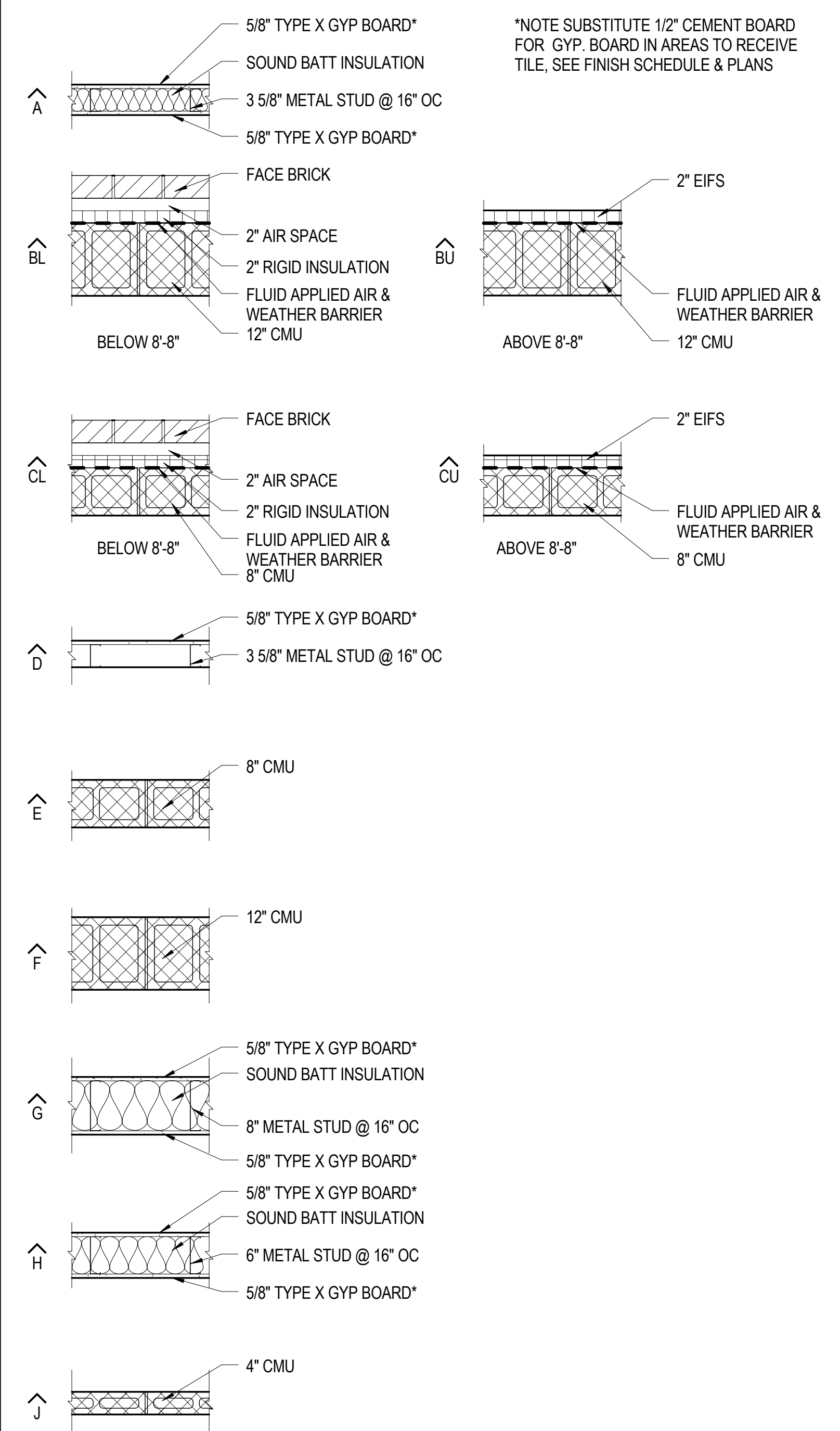

### ARCHITECTURAL SYMBOL LEGEND

**Base Plate Tag**  
 T = Thickness  
 B = Base  
 N = Width  
 Quantity of AR  
 Dimension of AR

**Break Line Symbol**

**Callout Head Symbol**  
 Description  
 Detail Cut or Section  
 Sheet Number

**Door Tag**  
 Door Schedule  
 Reference Number

**Drawing Revision Tag**  
 Revision Number

**Grid Head Symbol**  
 Grid Number

**Key Note Symbol**  
 Key Note Number

**Level Head Symbol**  
 Name  
 Elevation

**Room Tag**  
 Room name  
 Room Number  
 Area or Volume

**Section Head Symbol**  
 Direction of Section  
 Description  
 Detail Cut or Section  
 Sheet Number

**Slope Down Symbol**

**Spot Elevation Symbol**

**Step Down Symbol**

**Valley Symbol**

**View Reference Symbol**  
 Detail Cut or Section  
 Sheet Number

**Wall Tag**  
 Wall Schedule  
 Reference Number

**Window Tag**  
 Window Schedule  
 Reference Number

BUILDING STATISTICS		CODE SUMMARY					
<b>AREA (GROSS SQUARE FOOTAGE)</b>		<b>APPLICABLE CODES</b>		<b>HEIGHT AND AREA LIMITS</b>		<b>FIRE RESISTANCE OF STRUCTURAL ELEMENTS</b>	
Existing Basement	18,160 SF	BUILDING	INTERNATIONAL BUILDING CODE - 2015	MAXIMUM ALLOWED HEIGHT	75 ft	RATING (HOURS)	
Existing First Floor	127,158 SF	LIFE SAFETY	NFPA 101 - 2000	MAXIMUM ALLOWED AREA	68,440 SF/Floor	EXTERIOR WALLS	
Gym Addition	16,558 SF	ENERGY	INTERNATIONAL ENERGY CONSERVATION CODE - 2009			LOAD BEARING WALLS	0 Hours
		MECHANICAL	UNIFORM MECHANICAL CODE - 2012			NON-LOAD BEARING WALLS	0 Hours
		PLUMBING	UNIFORM PLUMBING CODE - 2012				
		ELECTRICAL	NATIONAL ELECTRICAL CODE - 2014				
		ACCESSIBILITY	2010 ADA STANDARDS FOR ACCESSIBLE DESIGN				
<b>OCCUPIED SPACE TOTAL</b>		<b>FIRE PROTECTIVE SYSTEMS</b>		<b>RATING (HRS)</b>			
Existing Building	145,318 SF	AUTO FIRE SUPPRESSION	YES	FIRE SEPARATION ASSEMBLIES		EXITS	0 Hours
New Separated Addition	16,558 SF	FIRE ALARM SYSTEM	YES	SHAFTS/ HOISTWAYS		INTERIOR LOAD BEARING WALLS, COLUMNS, FRAMING	0 Hours
		AUTO FIRE DETECTION	YES	FLOOR CONSTRUCTION		ROOF CONSTRUCTION	0 Hours
				FIRE WALL SEPARATION			Class A
							2 Hours
		<b>OCCUPANCY GROUP</b>	Group E				
		<b>TYPE OF CONSTRUCTION</b>	Type II B				



Revision Schedule	Description
No.	Date

Project Title: CHASE COUNTY SCHOOL - GYM ADDITION  
 520 EAST 9TH STREET  
 IMPERIAL, NEBRASKA 68903  
 CHASE COUNTY SCHOOLS

Sheet Title: ARCHITECTURAL NOTES, CODE SUMMARY AND SYMBOL LEGEND  
 Completion: 100% CONSTRUCTION DOCUMENTS  
 Date Issued: MAY 16, 2016

Project: 203-003-15

Design	Drawing	Check
JDW	JDS	JDW

Sheet No.

**A-0.01**

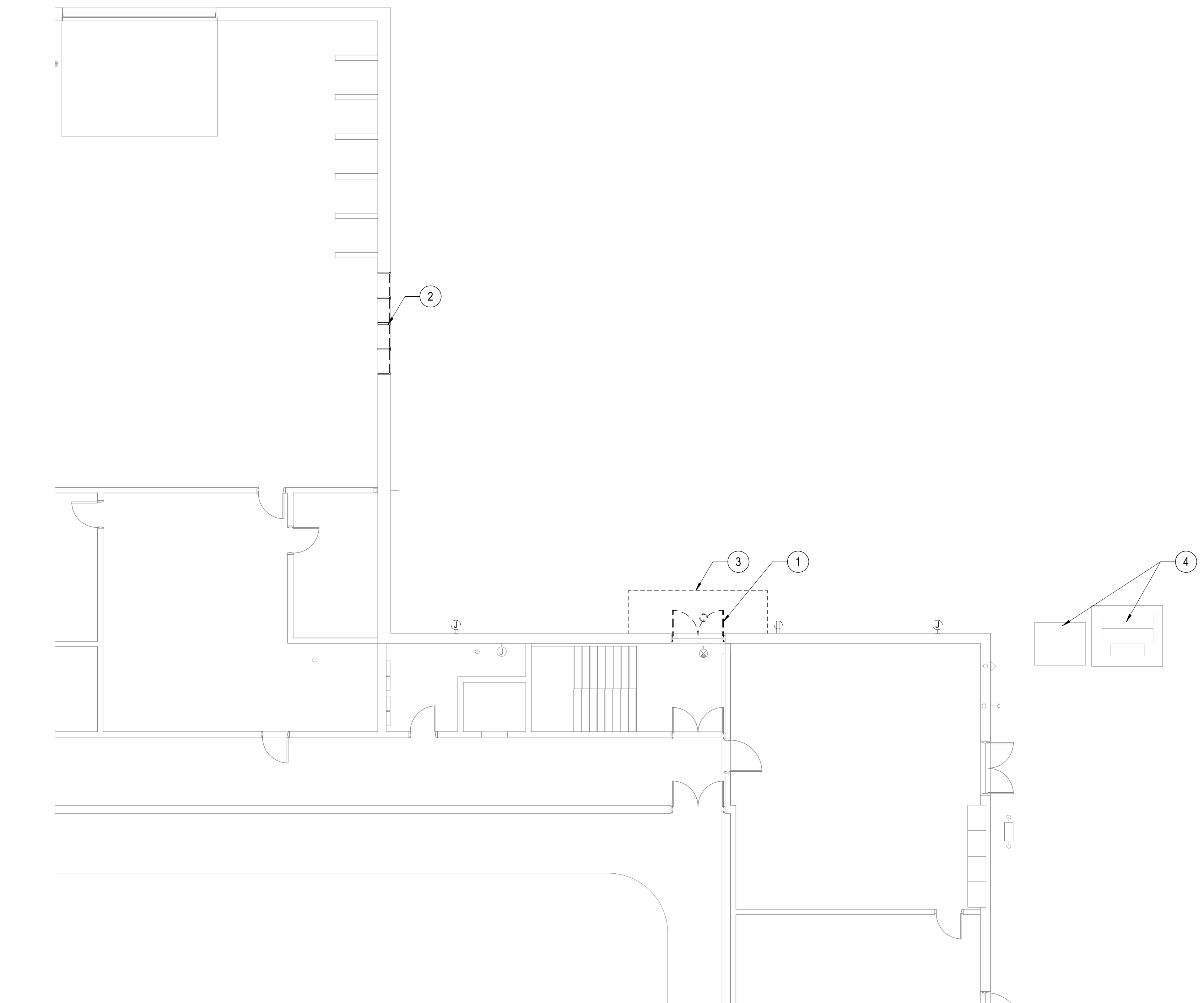

**1 GROUND LEVEL DEMOLITION**  
 1/8" = 1'-0"

**KEYNOTE LEGEND**

- ① REMOVE EXISTING DOOR & FRAME.
- ② REMOVE EXISTING WINDOW & FRAME.
- ③ REMOVE EXISTING ROOF, SOFFIT & SIDE WALLS ENTRYWAY OVERHANG.
- ④ PROTECT EXISTING TRANSFORMER & ELECTRICAL EQUIPMENT DURING ALL PHASES OF CONSTRUCTION.

**DEMOLITION GENERAL NOTES**

THE FOLLOWING ARE TYPICAL DEMOLITION GENERAL NOTES. REVISE AS REQUIRED.

1. DEMOLITION NOTES APPLY TO ALL SHEETS.
2. THE CONTRACTOR SHALL BE TOTALLY FAMILIAR WITH EXISTING CONDITIONS PRIOR TO BIDDING.
3. THE CONTRACTOR SHALL VERIFY ALL EXISTING CONDITIONS, DIMENSIONS AND ELEVATIONS AND SHALL IMMEDIATELY NOTIFY THE ARCHITECT OF ANY DISCREPANCIES.
4. DEMOLITION PLANS INDICATE GENERAL AREAS OF DEMOLITION. COORDINATE SPECIFIC LIMITS OF DEMOLITION WORK WITH THE REMODEL PLANS, DETAILS AND SPECIFICATIONS.
5. THE CONTRACTOR SHALL REMOVE ALL DEMOLITION MATERIALS FROM THE SITE UNLESS OTHERWISE NOTED. THE OWNER SHALL RESERVE THE RIGHT TO SALVAGE ANY MATERIALS.
6. THE CONTRACTOR SHALL CAREFULLY REMOVE ANY EXISTING MATERIALS IDENTIFIED AS SALVAGED FOR THE OWNER OR SALVAGED FOR REUSE AND SHALL BE RESPONSIBLE FOR MAINTAINING THE FUNCTIONAL AND AESTHETIC INTEGRITY OF THESE MATERIALS.
7. THE CONTRACTOR SHALL PROVIDE PROTECTION FOR ALL EXISTING (TO REMAIN) BUILDING MATERIALS AND EQUIPMENT FROM DAMAGE DUE TO ANY DEMOLITION OR CONSTRUCTION RELATED INCIDENT PERFORMED UNDER THIS CONTRACT.
8. THE CONTRACTOR SHALL REPAIR OR REPLACE ANY CEILINGS, WALLS, FLOORS, FINISHES, EQUIPMENT, ETC. DAMAGED AS A RESULT OF DEMOLITION, CONSTRUCTION MATERIALS DELIVERY OR DEBRIS REMOVAL, TO MATCH ORIGINAL EXISTING FINISH AND/OR CONDITIONS.
9. LOCATE AND MAINTAIN EXISTING UTILITIES SO AS NOT TO INTERRUPT THE CONTINUITY OF THEIR SERVICE. NO UTILITY IS TO BE INTERRUPTED UNLESS COORDINATED WITH THE OWNER.
10. UNLESS OTHERWISE INDICATED, REMOVE ALL DISCONNECTED MECHANICAL AND PLUMBING LINES WITHIN CEILINGS, WALLS AND/OR FLOORS.
11. REROUTE ANY EXISTING (TO REMAIN) DUCTWORK, WIRING, CONDUIT PLUMBING LINES, ETC. WHICH BECOME EXPOSED OR WOULD OTHERWISE INTERFERE WITH ANY DETAILED, SCHEDULED OR NOTED WALL OR CEILING CONDITION.
12. REMOVE, IN THEIR ENTIRETY, ALL EXISTING INTERIOR WALLS, CURBS, FLOOR FINISHES, FINISHES, DOORS, FRAMES, WINDOWS, MILLWORK, FIXTURES, MECHANICAL DUCTS, PLUMBING PIPES, ELECTRICAL LINES, ETC. IDENTIFIED ON THE DEMOLITION PLANS AND AS REQUIRED TO ACCOMMODATE THE NEW CONSTRUCTION.
13. DEMO EXISTING FLOOR, WALL AND CEILING FINISHES AS REQUIRED TO ACCOMMODATE NEW FINISHES SCHEDULED AS PART OF THE REMODEL WORK.
14. VERIFY EXISTING CONDITIONS OF FLOORS AND WALLS SCHEDULED TO RECEIVE NEW FINISHES. PATCH OR REPAIR HOLES AND IMPRESSIONS TO PROVIDE A SMOOTH FINISHED SURFACE.
15. WHERE EXISTING FLOOR FINISH MATERIALS ARE REMOVED, THE CONTRACTOR SHALL BE RESPONSIBLE TO PREPARE ALL SUBSTRATES AS REQUIRED TO RECEIVE NEW FLOOR FINISHES.
16. WHERE EXISTING WALL FINISH MATERIALS ARE REMOVED, THE CONTRACTOR SHALL BE RESPONSIBLE TO PREPARE ALL SUBSTRATES AS REQUIRED TO RECEIVE NEW WALL FINISHES.
17. PATCH AND/OR FILL WALL AND FLOOR PENETRATIONS AT DEMOLISHED PLUMBING, CONDUIT AND OTHER MISCELLANEOUS PENETRATIONS WHICH BECOME EXPOSED AS A RESULT OF DEMOLITION WORK.
18. COORDINATE WITH THE OWNER'S REPRESENTATIVE ALL WORK IDENTIFIED AS "N.I.C." OR "BY OWNER" SO AS TO COINCIDE WITH THE DEMOLITION/CONSTRUCTION PROCESS AND THE WORK SCHEDULE ESTABLISHED.
19. PATCH AND REPAIR EXISTING WALLS, CEILINGS, FLOORS, ETC. WHERE SELECTIVE DEMOLITION WORK OCCURS AND RESULTS IN AN EXPOSED UNFINISHED SURFACE ON MATERIALS THAT REMAIN.



Revision No.	Schedule Date	Description

Project Title: CHASE COUNTY SCHOOL - GYM ADDITION  
 520 EAST 9TH STREET  
 IMPERIAL, NEBRASKA 68033  
 CHASE COUNTY SCHOOLS

Sheet Title: GROUND LEVEL DEMOLITION  
 Completion: 100% CONSTRUCTION DOCUMENTS  
 Date Issued: MAY 16, 2016

Project: 203-003-15

Design Drawing Check  
 Designer Author Checker

Sheet No. A-0.10

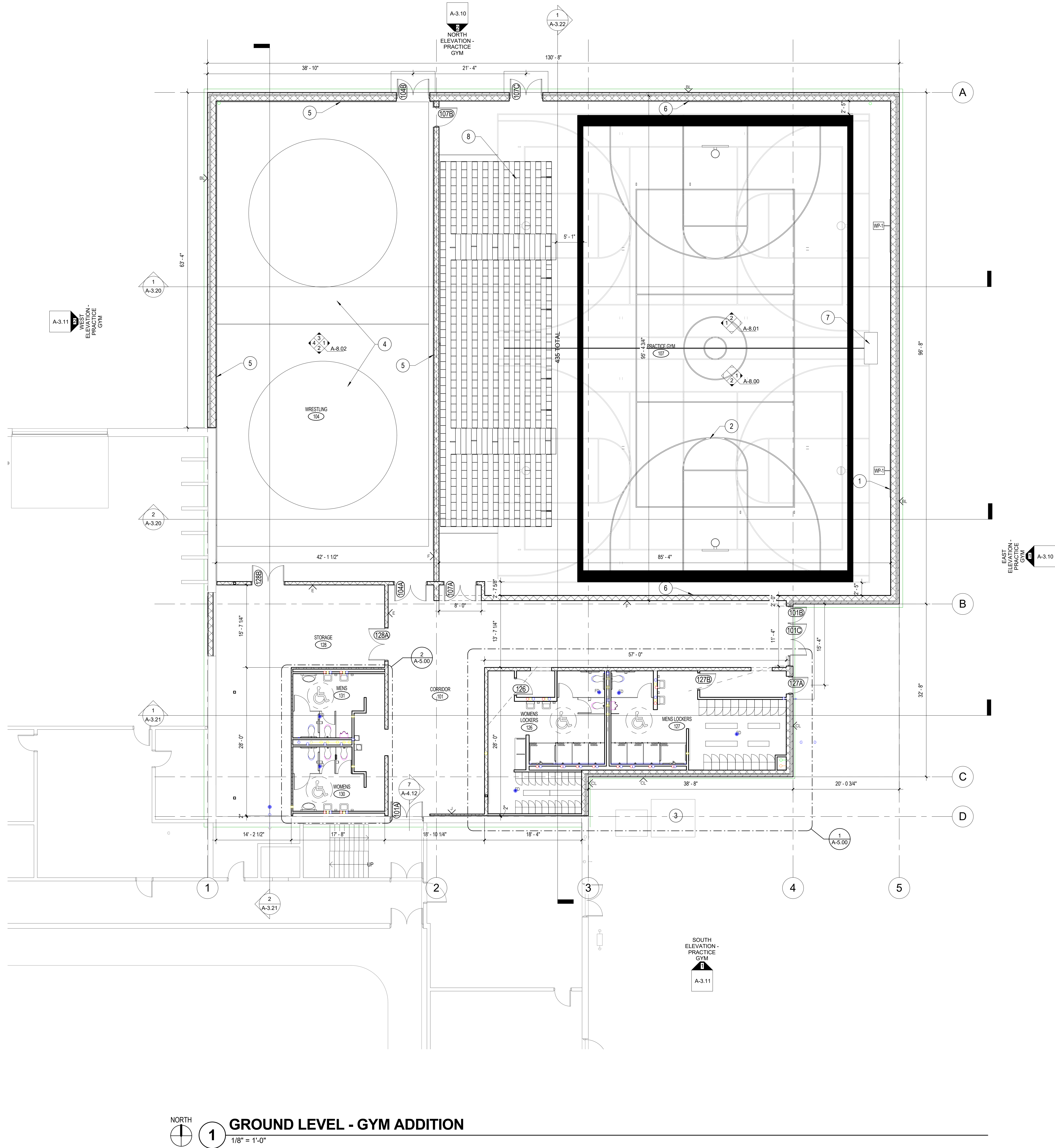

**1** NORTH  
**GROUND LEVEL - GYM ADDITION**  
 1/8" = 1'-0"

**KEYNOTE LEGEND**

- 1 WP-1 - 6'X10' 2" THICK GYM WALL PADDING.
- 2 FLOOR STRIPING PER NSAA GUIDELINES, 1 MAIN COURT & 2 SIDE COURTS.
- 3 EXISTING ELECTRICAL TRANSFORMER TO REMAIN.
- 4 WRESTLING MATS, BY OWNER.
- 5 6" H - 2" THICK WALL PADDING AROUND PERIMETER OF WRESTLING MATS.
- 6 GYM WALL PADDING, BY OWNER.
- 7 SCORER'S TABLE, NIC.
- 8 11 ROW FOLDING BLEACHER SYSTEM, 435 SEATS TOTAL.



Revision Schedule	No.	Date	Description

Project Title: **CHASE COUNTY SCHOOL - GYM ADDITION**  
 520 EAST 9TH STREET  
 IMPERIAL, NEBRASKA 68033  
 CHASE COUNTY SCHOOLS

Sheet Title: **GROUND LEVEL PLAN**  
 Completion: 100% CONSTRUCTION DOCUMENTS  
 Date Issued: MAY 16, 2016

Project: 203-003-15

Design: JDW Drawing: JDS Check: JDW

Sheet No. **A-1.00**

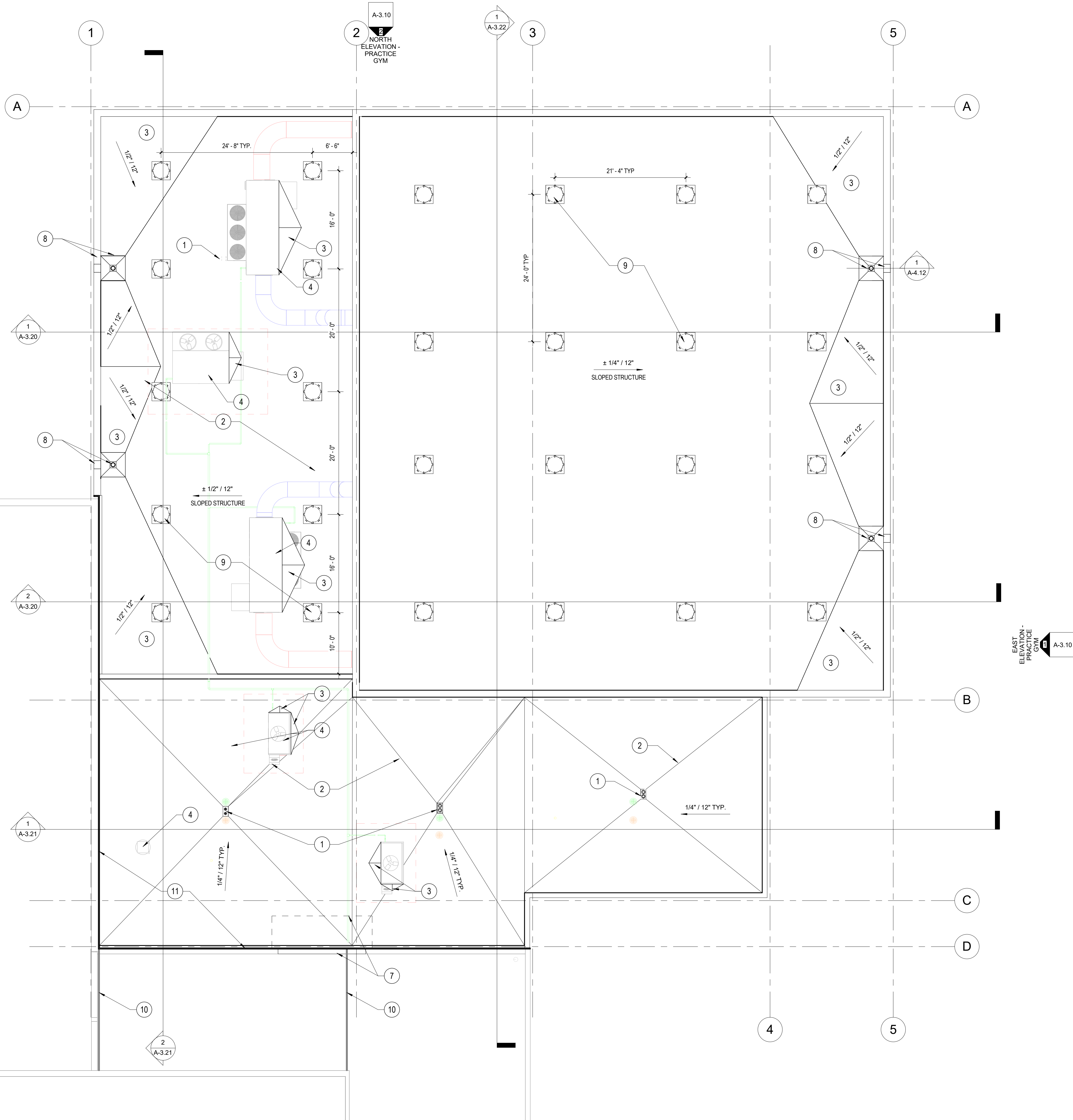

**1** NORTH  
**ROOF PLAN**  
 1/8" = 1'-0"

**KEYNOTE LEGEND**

- 1 ONE PIECE COMBINATION ROOF DRAIN WITH SECONDARY OVERFLOW TYP., SEE PLUMBING.
- 2 TAPERED ROOF INSULATION, SLOPE TO ROOF DRAIN TYP.
- 3 TAPERED INSULATION CRICKET, SLOPE TO ROOF DRAIN. COORDINATE ROOF CURBS & CRICKETS NOT SHOWN HEREON FOR ALL MECHANICAL EQUIPMENT.
- 4 ROOFTOP EQUIPMENT, SEE MECHANICAL.
- 5 ROOF WALKWAY MATS.
- 6 EXISTING ROOF TO REMAIN.
- 7 REMOVE EXISTING AWNING, CONSTRUCT NEW PARAPET WALL TO ENCLOSE EXISTING ROOF. MODIFY EXISTING ROOFING MEMBRANE, INSULATION & PARAPET AS NECESSARY TO ENSURE INTEGRITY OF EXISTING ROOF.
- 8 ROOF DRAIN WITH SCUPPER OVERFLOW, SEE PLUMBING.
- 9 SOLATUBE SKYVAULT SERIES, TYP.
- 10 EX. 2" EXPANSION JOINT
- 11 2" EXPANSION JOINT



Revision Schedule	Description
No.   Date	

Project Title:  
**CHASE COUNTY SCHOOL - GYM ADDITION**  
 520 EAST 9TH STREET  
 IMPERIAL, NEBRASKA 68033  
 CHASE COUNTY SCHOOLS

Sheet Title:  
**ROOF PLAN**  
 Completion: 100% CONSTRUCTION DOCUMENTS  
 Date Issued: MAY 16, 2016

Project:	203-003-15	
Design Designer:	Drawing Author:	Check Checker:

Sheet No.  
**A-1.10**

**GROUND LEVEL**  
 1/8" = 1'-0"

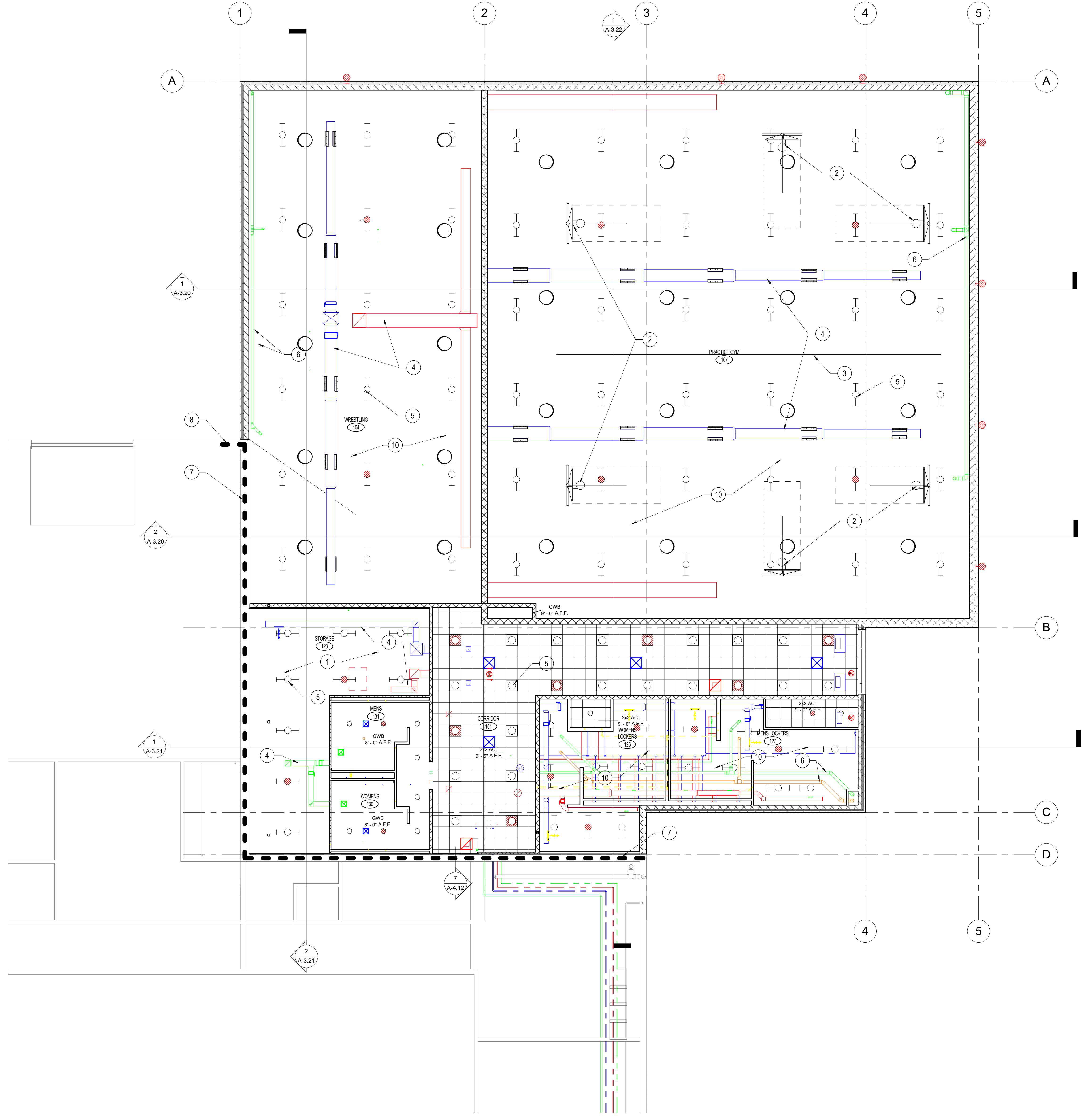

**KEYNOTE LEGEND**

- 1 OPEN TO STRUCTURE.
- 2 FORWARD FOLDING BASKETBALL BACKSTOP WITH FRONT SUPPORT.
- 3 GYM DIVIDER CURTAIN.
- 4 HVAC DUCT, SEE MECHANICAL DRAWINGS TYP.
- 5 LIGHT FIXTURE, SEE ELECTRICAL DRAWINGS TYP.
- 6 PLUMBING PIPING, SEE PLUMBING DRAWINGS TYP.
- 7 MODIFY EXISTING WALL AS NECESSARY INCLUDING SEALING ALL PENETRATIONS AND OPENINGS AS REQUIRED FOR A 2 HOUR FIRE WALL RATING.
- 8 EXTEND 2 HOUR RATING 4'-0" BEYOND CORNER.
- 9 BALCO 75FCAC-2 EXPANSION COVER
- 10 OPEN TO STRUCTURE, PAINT ALL STRUCTURAL FRAMING, DECKING & EXPOSED MEP INSTALLATIONS, COLOR TO BE SELECTED BY ARCHITECT.

**CEILING LEGEND**

GRAPHIC SYMBOL	DESCRIPTION
	RECESSED LIGHT FIXTURE
	RECESSED INDIRECT LIGHT FIXTURE
	WALL MOUNTED LIGHT FIXTURE
	SUSPENDED LINEAR FIXTURE
	STRIP LIGHT FIXTURE
	RECESSED DOWNLIGHT FIXTURE
	RECESSED WALL WASH DOWNLIGHT FIXTURE
	PENDANT FIXTURE
	WALL MOUNTED LIGHT FIXTURE
	EXIT SIGN
	SUPPLY DIFFUSER - SEE MECHANICAL
	RETURN GRILLE - SEE MECHANICAL
	GYP BD CEILING
	ACOUSTIC PANEL CEILING
	2 HOUR FIRE WALL



Revision Schedule	Description
No.	Date

Project Title: CHASE COUNTY SCHOOL - GYM ADDITION  
 520 EAST 9TH STREET  
 IMPERIAL, NEBRASKA 68033  
 CHASE COUNTY SCHOOLS

Sheet Title: GROUND LEVEL REFLECTED CEILING PLAN  
 Completion: 100% CONSTRUCTION DOCUMENTS  
 Date Issued: MAY 16, 2016

Project: 203-003-15

Design: JDW Drawing: JDS Check: JDW

Sheet No. A-2.00

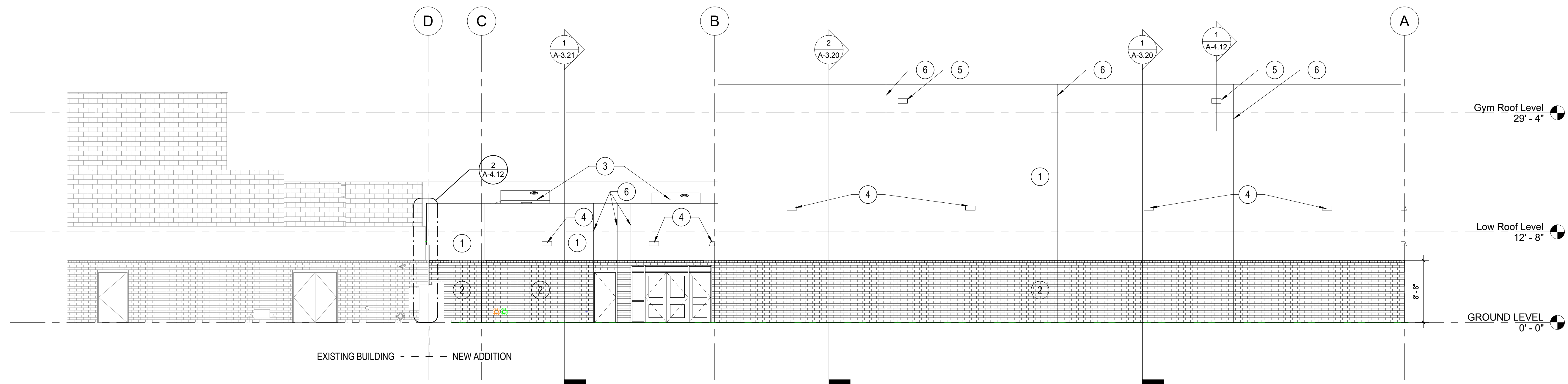

**1** 1/8" = 1'-0" EAST ELEVATION - PRACTICE GYM

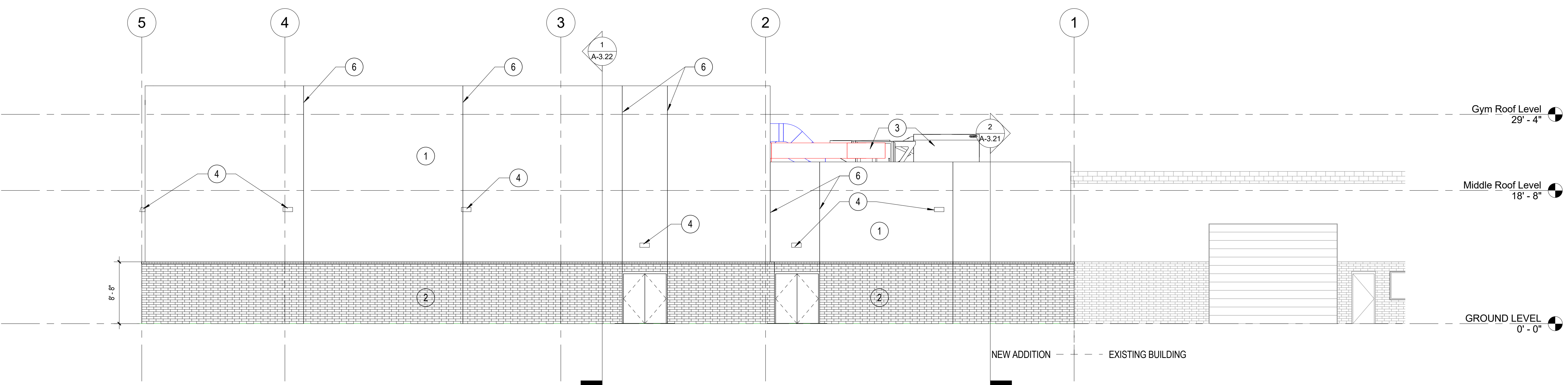

**2** 1/8" = 1'-0" NORTH ELEVATION - PRACTICE GYM

**KEYNOTE LEGEND**

- 1 EIFS, COLOR TO MATCH EXISTING.
- 2 FACE BRICK, COLOR TO MATCH EXISTING.
- 3 MECHANICAL EQUIPMENT, SEE MECHANICAL.
- 4 LIGHT FIXTURE, SEE ELECTRICAL.
- 5 OVERFLOW SCUPPER, SEE ROOF PLAN A-1.10.
- 6 CONTROL JOINT, TYP.

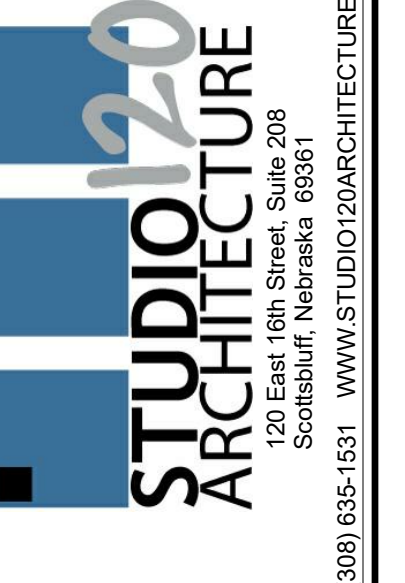

Sub-Consultant

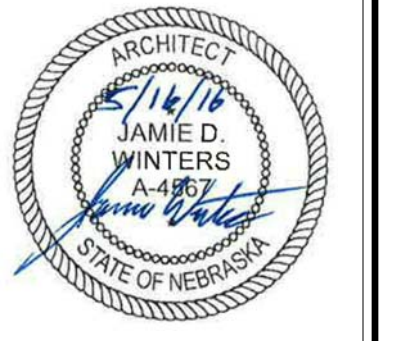

Revision Schedule

No. | Date | Description

Project Title:  
**CHASE COUNTY SCHOOL - GYM ADDITION**

520 EAST 9TH STREET  
 IMPERIAL, NEBRASKA 68033  
**CHASE COUNTY SCHOOLS**

Sheet Title:  
**EXTERIOR BUILDING ELEVATIONS**

Completion: 100% CONSTRUCTION DOCUMENTS  
 Date Issued: MAY 16, 2016

Project: 203-003-15

Design Drawing Check  
 JDW JDS JDW

Sheet No.

**A-3.10**

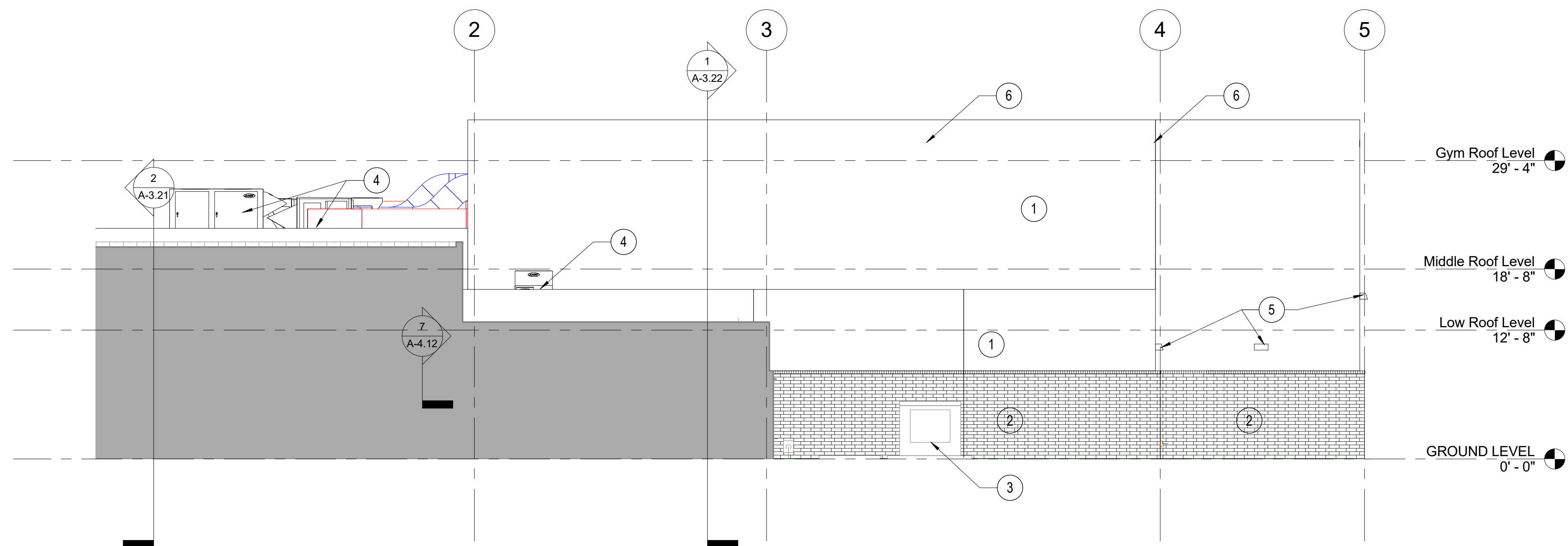

**1** 1/8" = 1'-0" SOUTH ELEVATION - PRACTICE GYM

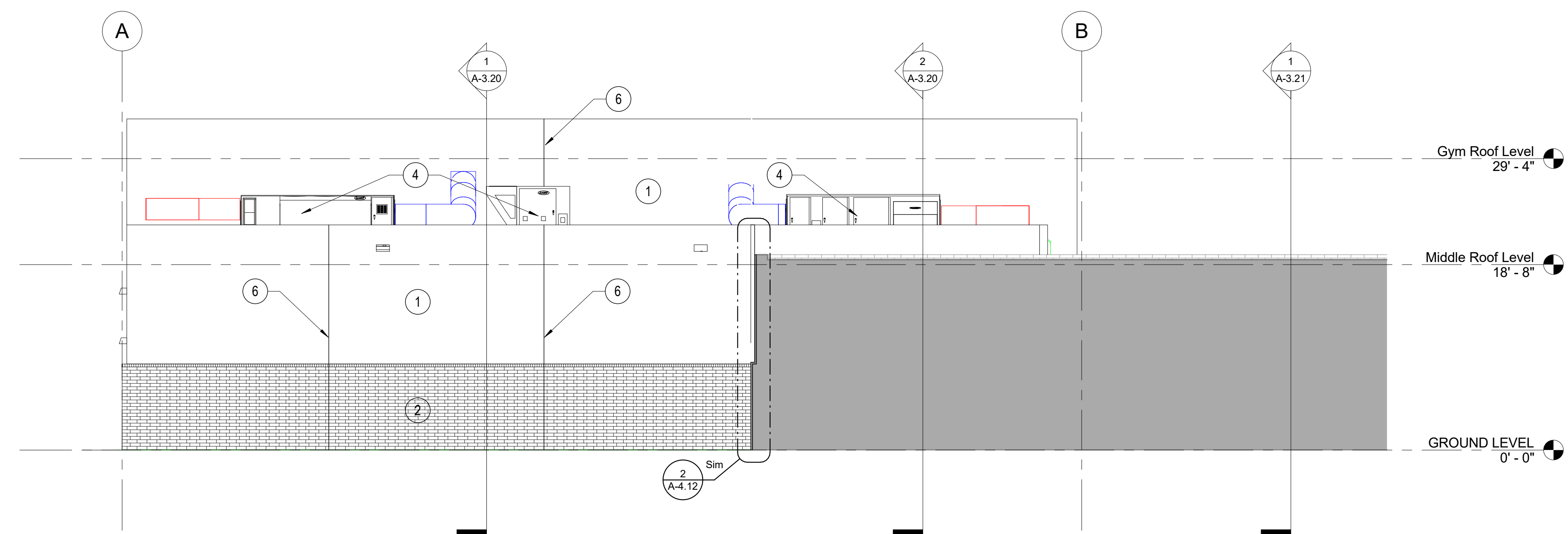

**2** 1/8" = 1'-0" WEST ELEVATION - PRACTICE GYM

**KEYNOTE LEGEND**

- 1 EIFS, COLOR TO MATCH EXISTING.
- 2 FACE BRICK, COLOR TO MATCH EXISTING.
- 3 EXISTING ELECTRICAL TRANSFORMER.
- 4 MECHANICAL EQUIPMENT, SEE MEP DRAWINGS.
- 5 LIGHT FIXTURE, SEE ELECTRICAL.



Sub-Consultant



Revision Schedule		Description	
No.	Date		

Project Title:  
**CHASE COUNTY SCHOOL - GYM ADDITION**  
 520 EAST 9TH STREET  
 IMPERIAL, NEBRASKA 68033  
 CHASE COUNTY SCHOOLS

Sheet Title:  
**EXTERIOR BUILDING ELEVATIONS**

Completion: 100% CONSTRUCTION DOCUMENTS  
 Date Issued: MAY 16, 2016

Project: 203-003-15

Design	Drawing	Check
JDW	JDS	JDW

Sheet No.

**A-3.11**

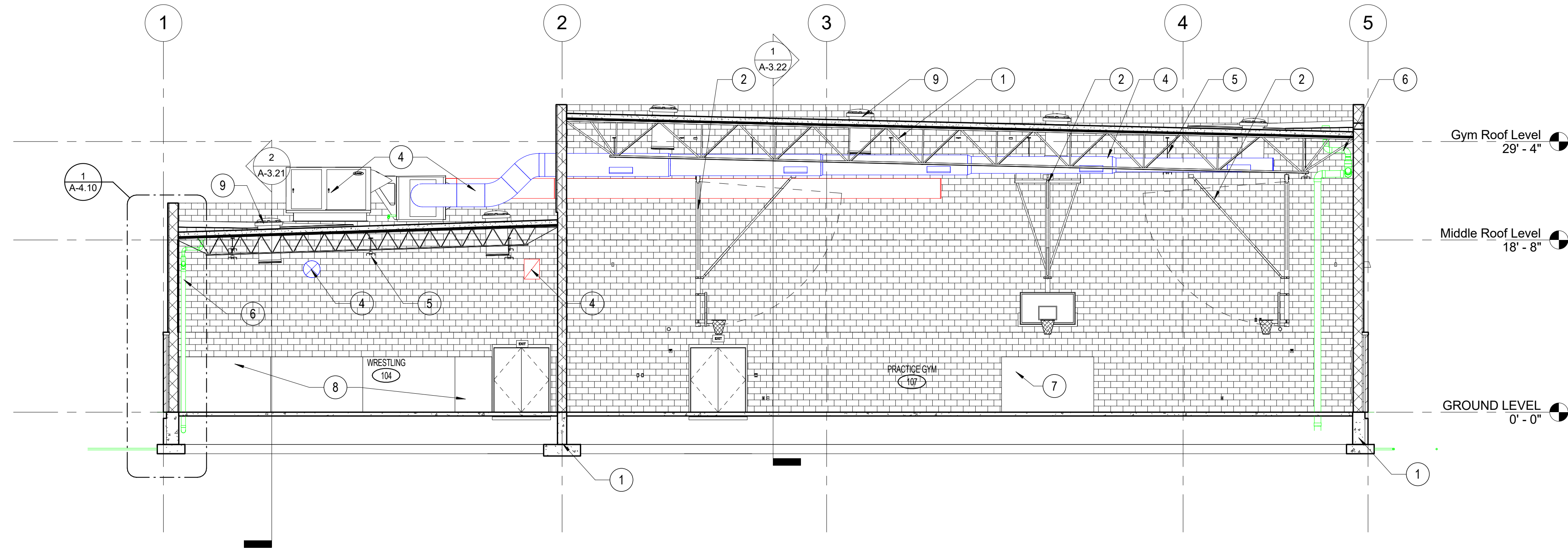

**1** 1/8" = 1'-0" BUILDING SECTION - E-W VIEW - WRESTLING & PRACTICE GYM 1

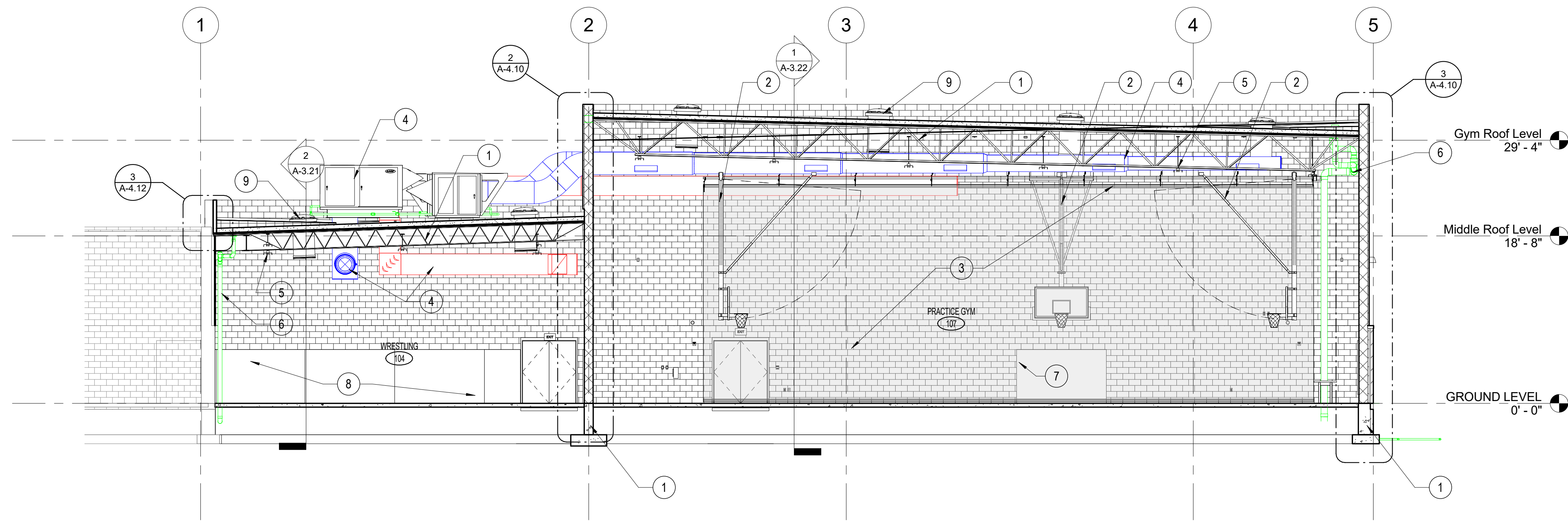

**2** 1/8" = 1'-0" BUILDING SECTION - E-W VIEW - WRESTLING & PRACTICE GYM 2

**KEYNOTE LEGEND**

- 1 SEE STRUCTURAL FOR DETAILS
- 2 FORWARD FOLDING BASKETBALL BACKSTOP WITH FRONT SUPPORT.
- 3 GYM DIVIDER CURTAIN.
- 4 HVAC DUCT/EQUIPMENT, SEE MECHANICAL DRAWINGS TYP.
- 5 LIGHT FIXTURE, SEE ELECTRICAL DRAWINGS TYP.
- 6 PLUMBING PIPING, SEE PLUMBING DRAWINGS TYP.
- 7 GYM WALL PADDING, BY OWNER.
- 8 6" H - 2" THICK WALL PADDING AROUND PERIMETER OF WRESTLING MATS.
- 9 SOLATUBE SKYVAULT SERIES, SEE ROOF PLAN.



Revision Schedule		Description	
No.	Date		

Project Title:  
**CHASE COUNTY SCHOOL - GYM ADDITION**  
 520 EAST 9TH STREET  
 IMPERIAL, NEBRASKA 68033  
 CHASE COUNTY SCHOOLS

Sheet Title:  
**BUILDING SECTIONS**  
 Completion: 100% CONSTRUCTION DOCUMENTS  
 Date Issued: MAY 16, 2016

Project: 203-003-15

Design	Drawing	Check
JDW	JDS	JDW

Sheet No.  
**A-3.20**

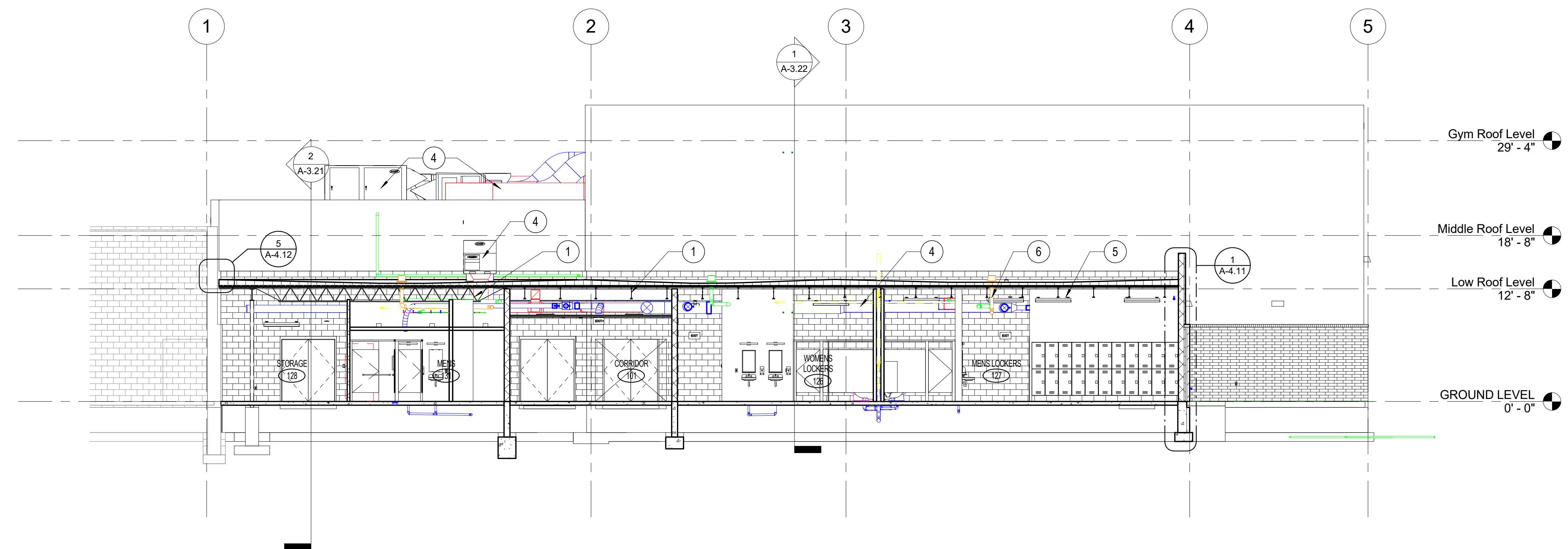

**KEYNOTE LEGEND**

- 1 SEE STRUCTURAL FOR DETAILS
- 2 SOLATUBE SKYVAULT SERIES, SEE ROOF PLAN.
- 3 6 H - 2" THICK WALL PADDING AROUND PERIMETER OF WRESTLING MATS.
- 4 HVAC DUCT/EQUIPMENT, SEE MECHANICAL DRAWINGS TYP.
- 5 LIGHT FIXTURE, SEE ELECTRICAL DRAWINGS TYP.
- 6 PLUMBING PIPING, SEE PLUMBING DRAWINGS TYP.
- 7

**1** 1/8" = 1'-0" BUILDING SECTION - E-W VIEW - STORAGE, MENS RESTROOM, CORRIDOR, LOCKERS

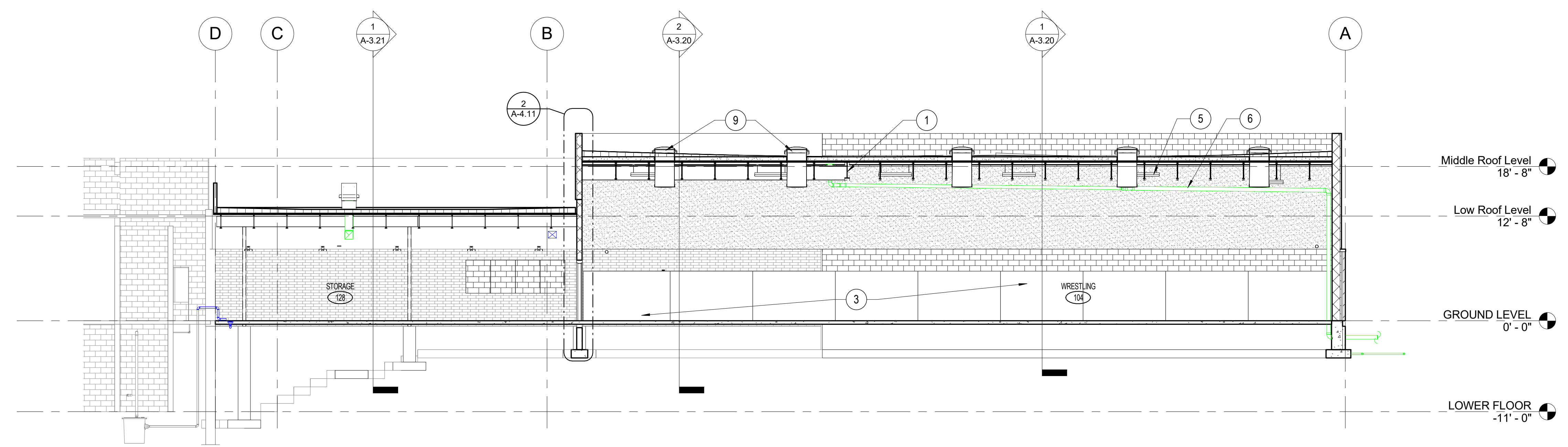

**2** 1/8" = 1'-0" BUILDING SECTION - N-S VIEW - STORAGE & WRESTLING



Revision Schedule	
No.	Description

Project Title:  
**CHASE COUNTY SCHOOL - GYM ADDITION**  
 520 EAST 9TH STREET  
 IMPERIAL, NEBRASKA 68033  
 CHASE COUNTY SCHOOLS

Sheet Title:  
**BUILDING SECTIONS**  
 Completion: 100% CONSTRUCTION DOCUMENTS  
 Date Issued: MAY 16, 2016

Project: 203-003-15

Design Drawing Check  
 JDW JDS JDW

Sheet No.  
**A-3.21**

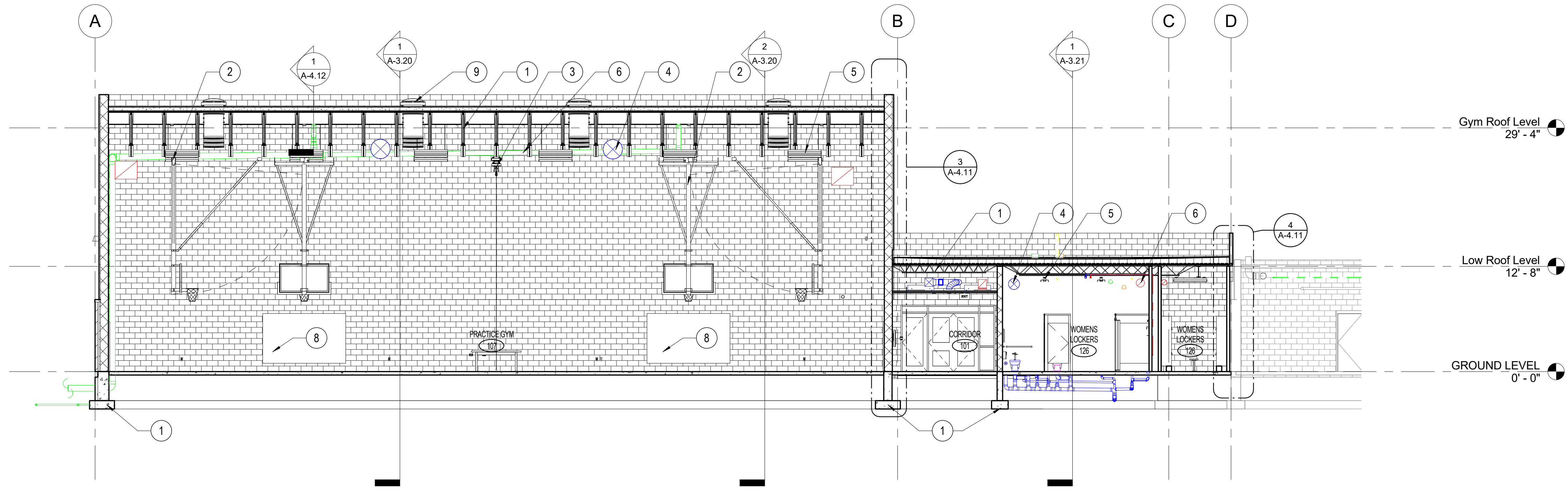

**KEYNOTE LEGEND**

- 1 SEE STRUCTURAL FOR DETAILS
- 2 FORWARD FOLDING BASKETBALL BACKSTOP WITH FRONT SUPPORT.
- 3 GYM DIVIDER CURTAIN.
- 4 HVAC DUCT/EQUIPMENT, SEE MECHANICAL DRAWINGS TYP.
- 5 LIGHT FIXTURE, SEE ELECTRICAL DRAWINGS TYP.
- 6 PLUMBING PIPING, SEE PLUMBING DRAWINGS TYP.
- 7 GYM WALL PADDING, BY OWNER.
- 8 6" H - 2" THICK WALL PADDING.
- 9 SOLATUBE SKYVAULT SERIES, SEE ROOF PLAN.

**1** 1/8" = 1'-0" BUILDING SECTION - N-S VIEW - PRACTICE GYM, CORRIDOR, WOMENS LOCKERS



Revision Schedule	
No.	Description

Project Title:  
**CHASE COUNTY SCHOOL - GYM ADDITION**  
 520 EAST 9TH STREET  
 IMPERIAL, NEBRASKA 68033  
 CHASE COUNTY SCHOOLS

Sheet Title:  
**BUILDING SECTIONS**  
 Completion: 100% CONSTRUCTION DOCUMENTS  
 Date Issued: MAY 16, 2016

Project: 203-003-15

Design Drawing Check  
 JDW JDS JDW

Sheet No.

**A-3.22**

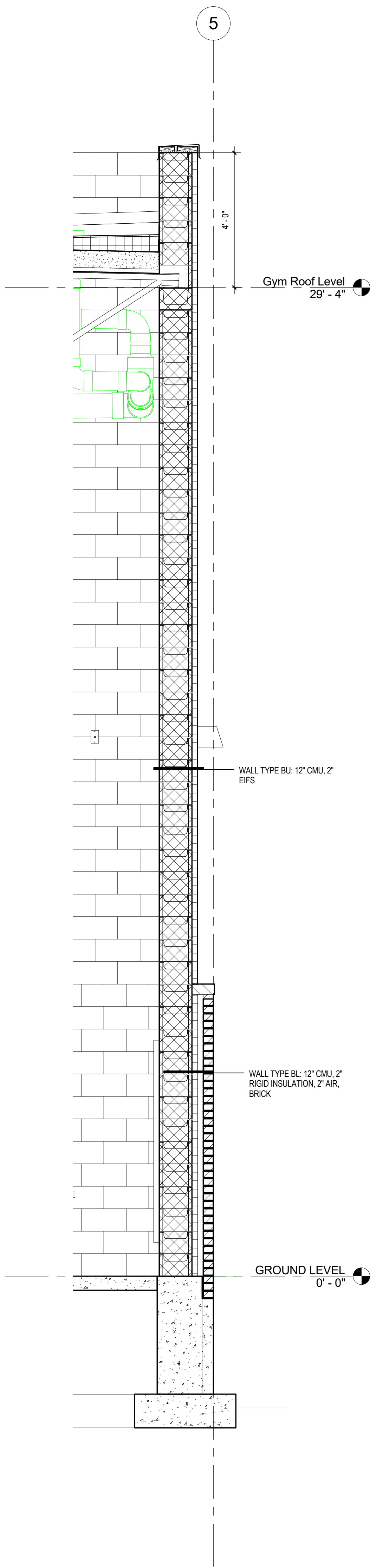

**3** 1/2" = 1'-0" WALL SECTION - PRACTICE GYM EAST WALL

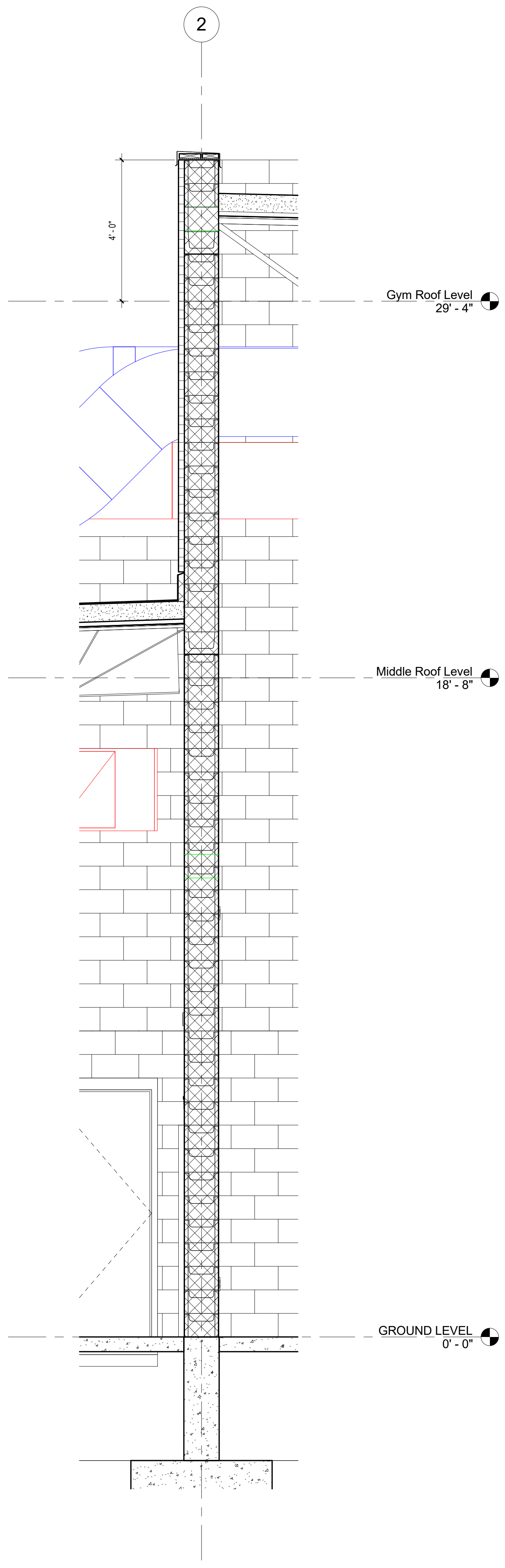

**2** 1/2" = 1'-0" WALL SECTION - WRESTLING & PRACTICE GYM

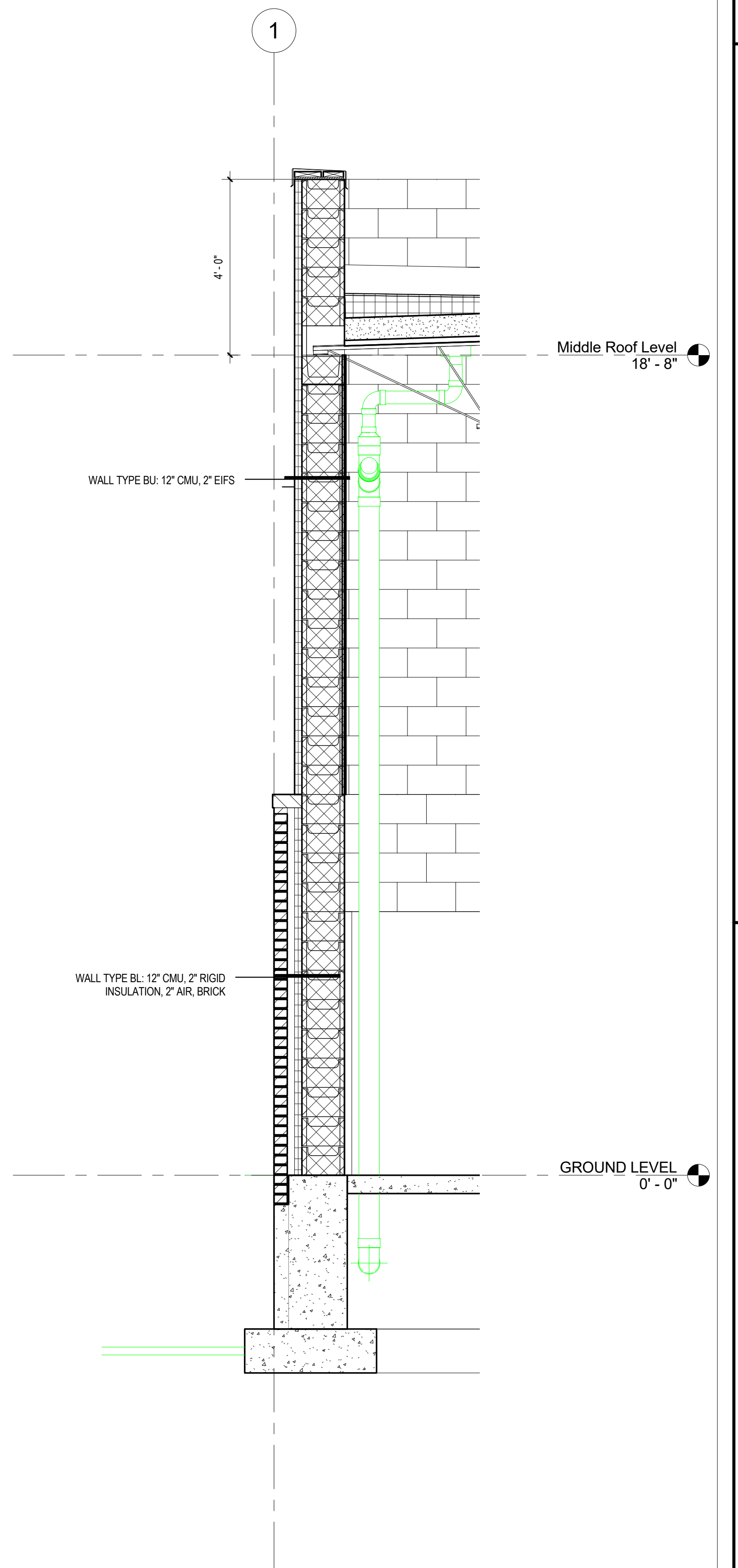

**1** 1/2" = 1'-0" WALL SECTION - WRESTLING WEST WALL



Revision Schedule	No.	Date	Description

Project Title: CHASE COUNTY SCHOOL - GYM ADDITION  
 520 EAST 9TH STREET  
 IMPERIAL, NEBRASKA 68033  
 CHASE COUNTY SCHOOLS

Sheet Title: WALL SECTIONS  
 Completion: 100% CONSTRUCTION DOCUMENTS  
 Date Issued: MAY 16, 2016

Project: 203-003-15

Design Drawing Check  
 JDW JDS JDW

Sheet No.

**A-4.10**

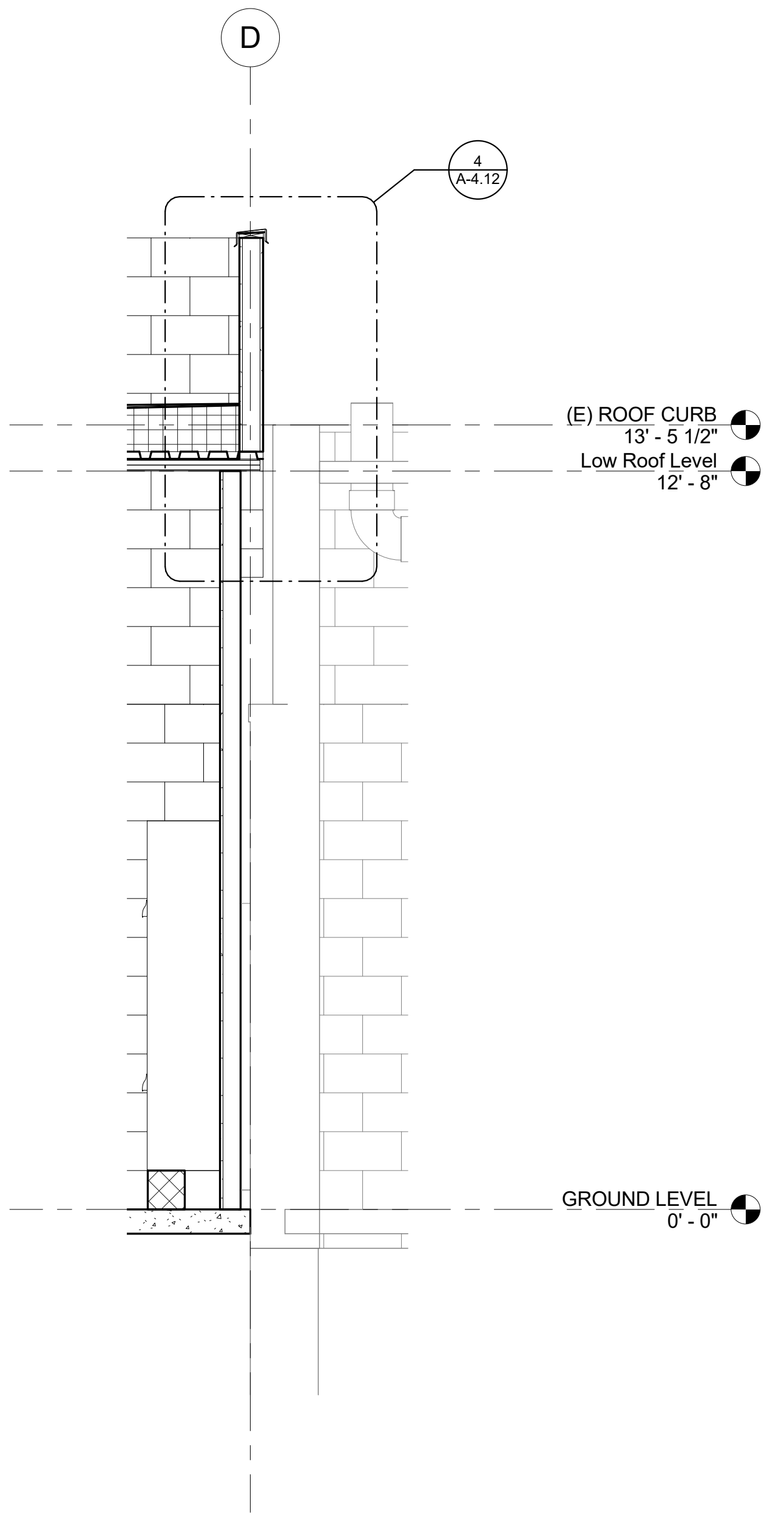

**4** 1/2" = 1'-0" WALL SECTION - WOMENS LOCKERS AT EXISTING

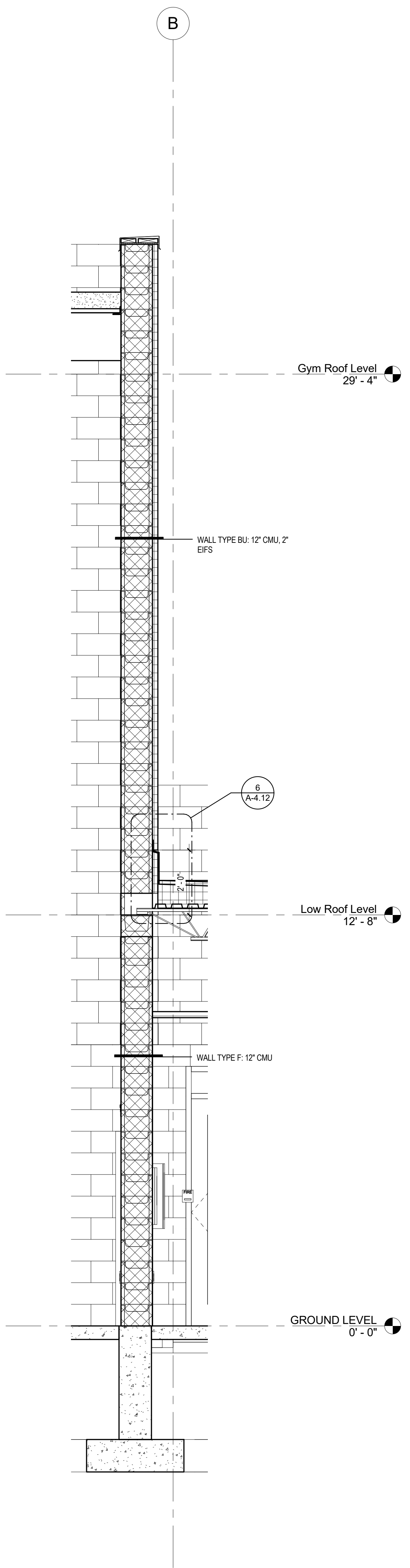

**3** 1/2" = 1'-0" WALL SECTION - PRACTICE GYM & CORRIDOR

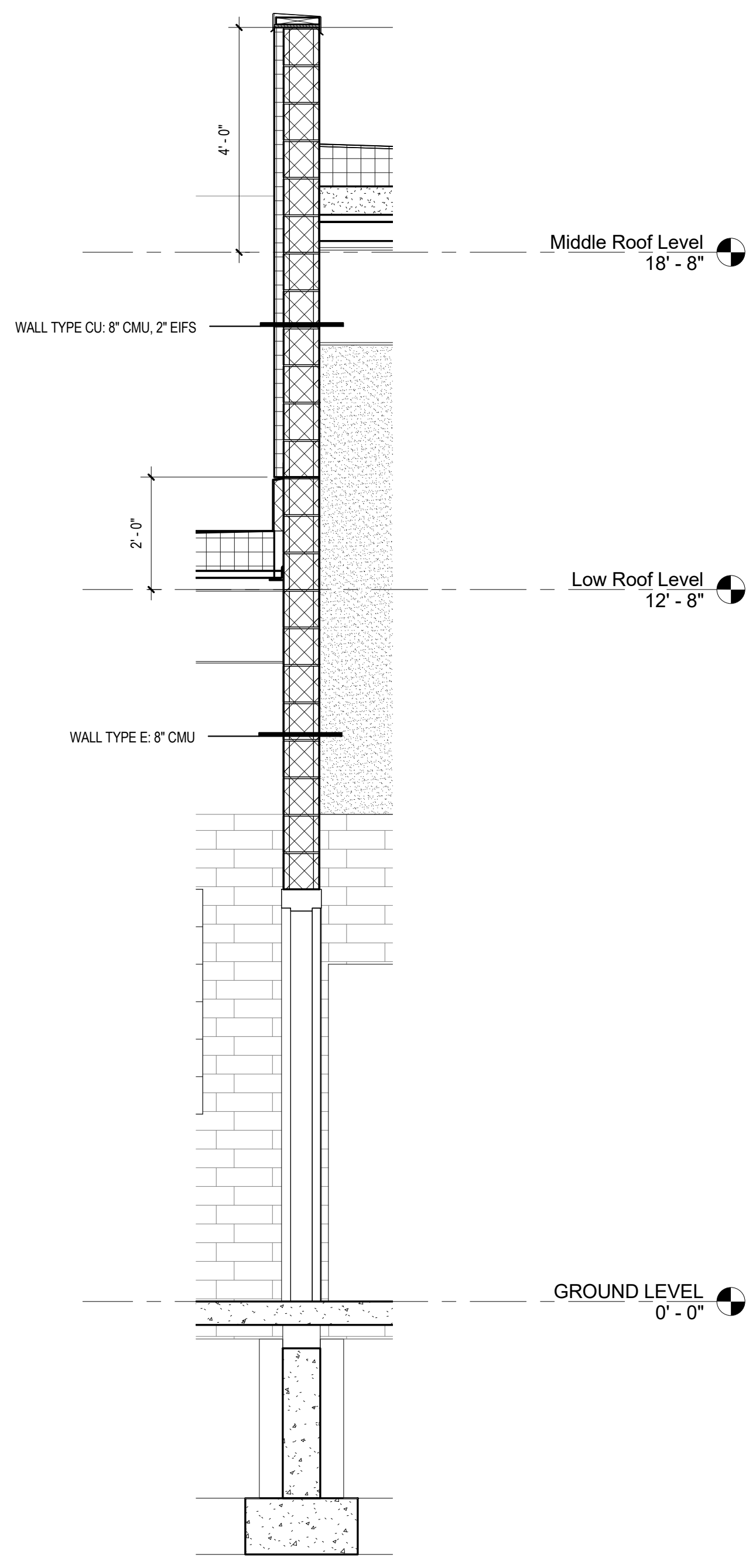

**2** 1/2" = 1'-0" WALL SECTION - STORAGE & WRESTLING

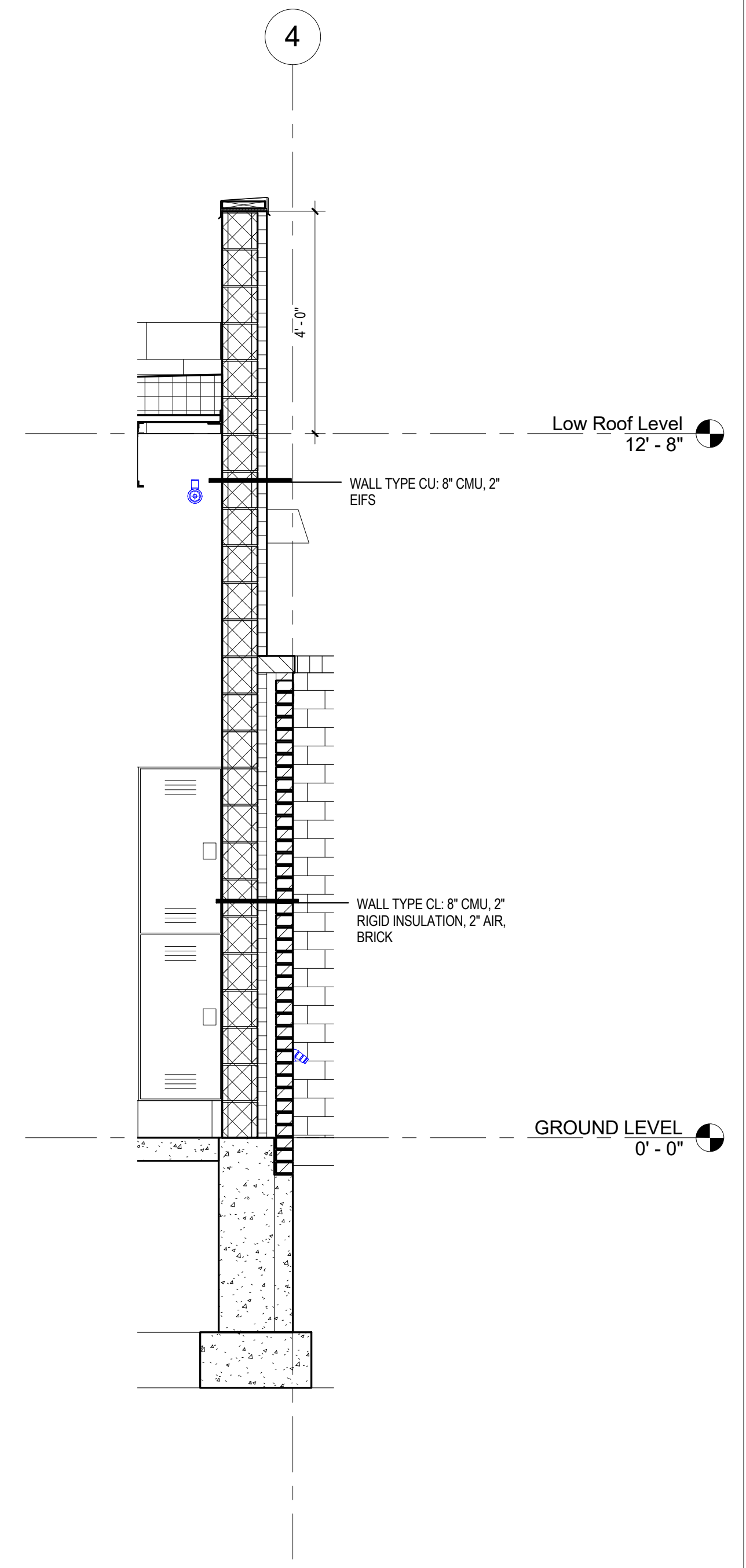

**1** 1/2" = 1'-0" WALL SECTION - MENS LOCKERS



Revision Schedule	No.	Date	Description

Project Title: CHASE COUNTY SCHOOL - GYM ADDITION  
 520 EAST 9TH STREET  
 IMPERIAL, NEBRASKA 68033  
 CHASE COUNTY SCHOOLS

Sheet Title: WALL SECTIONS  
 Completion: 100% CONSTRUCTION DOCUMENTS  
 Date Issued: MAY 16, 2016

Project: 203-003-15

Design Drawing Check  
 JDW JDS JDW

Sheet No. A-4.11

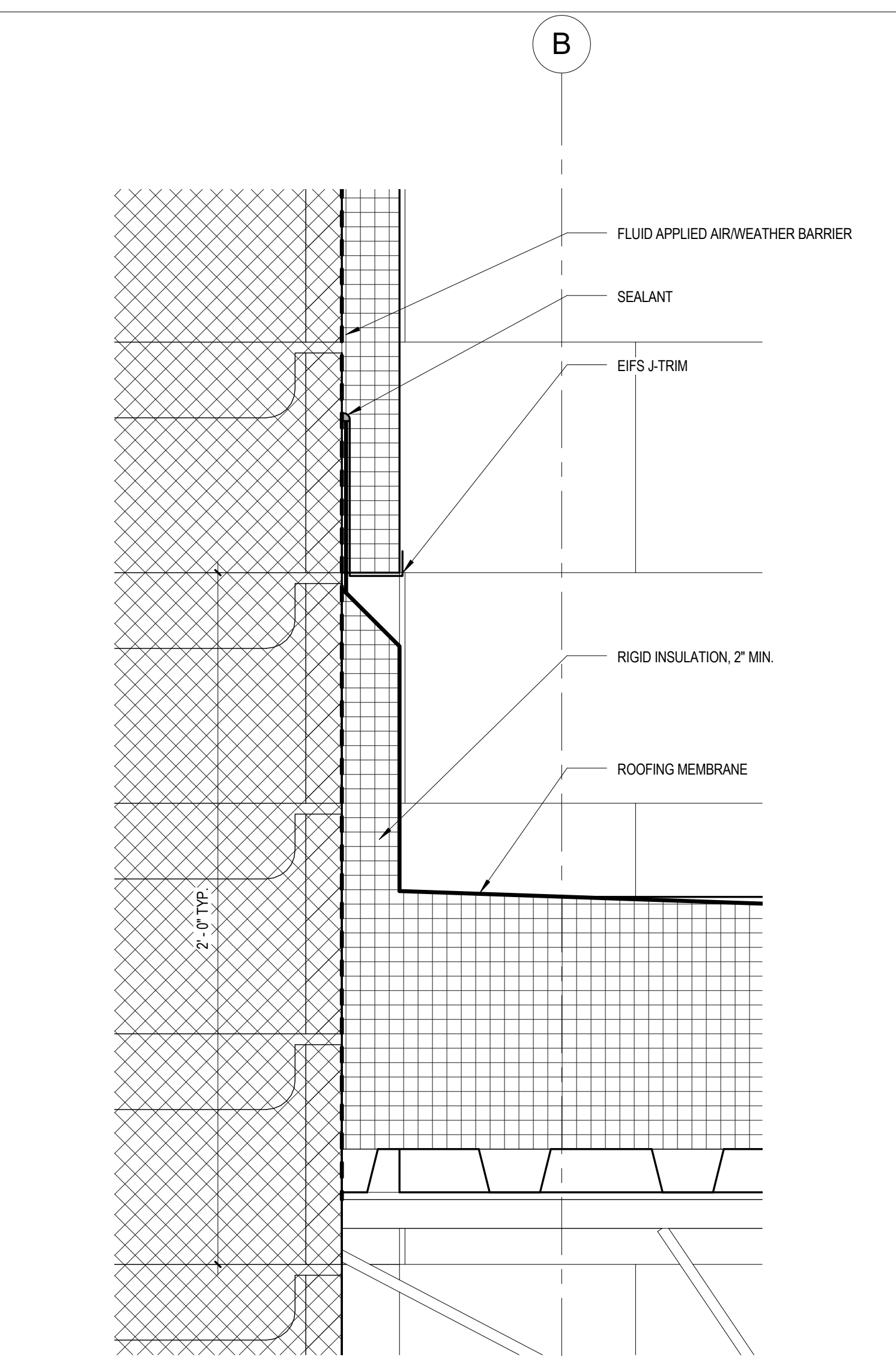

**6 ROOF DETAIL - TYP. EIFS TERMINATION**  
 3" = 1'-0"

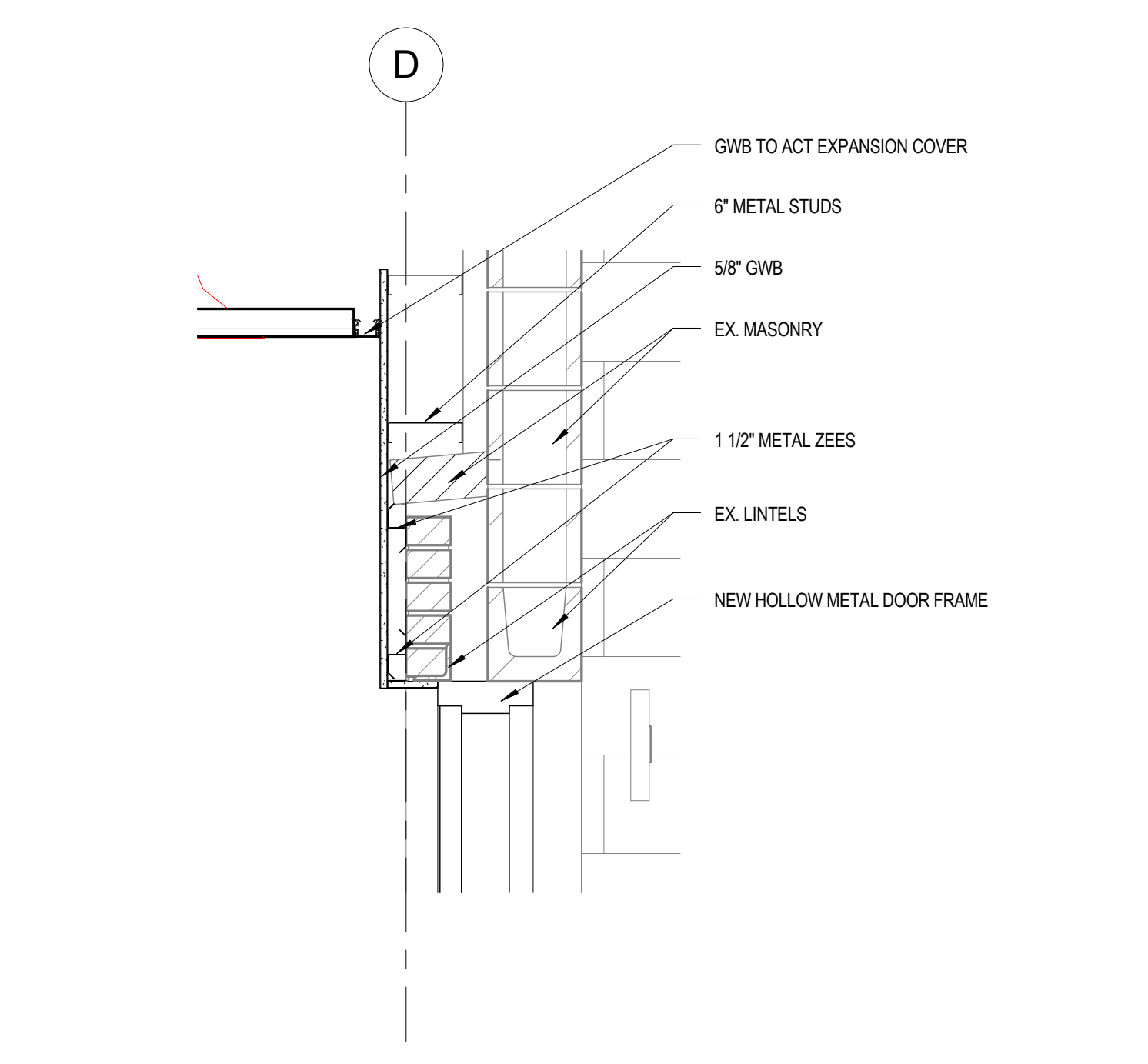

**7 DOOR HEAD DETAIL @ EXISTING WALL**  
 1" = 1'-0"

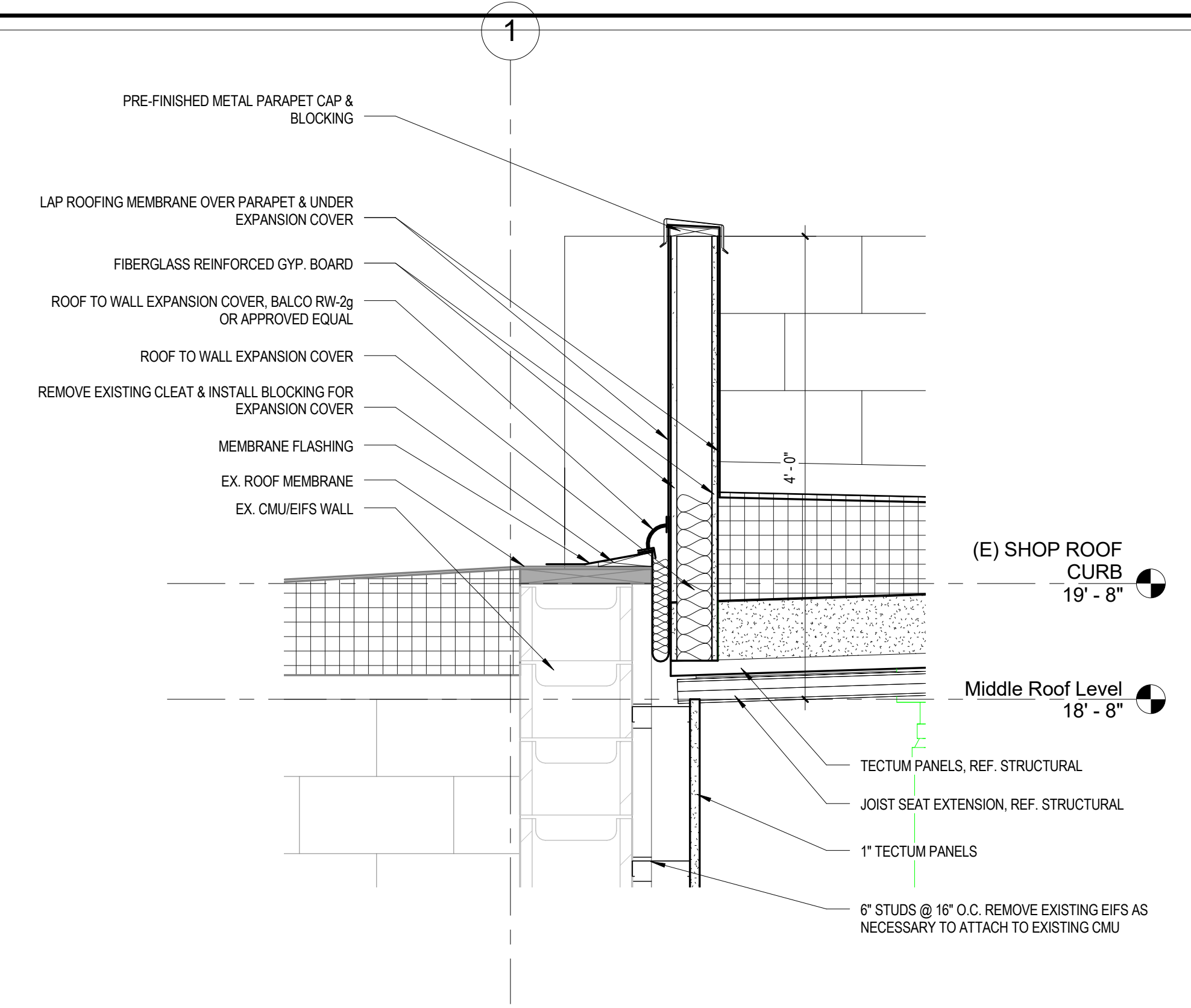

**3 ROOF DETAIL - WEST EXP. JOINT**  
 1" = 1'-0"

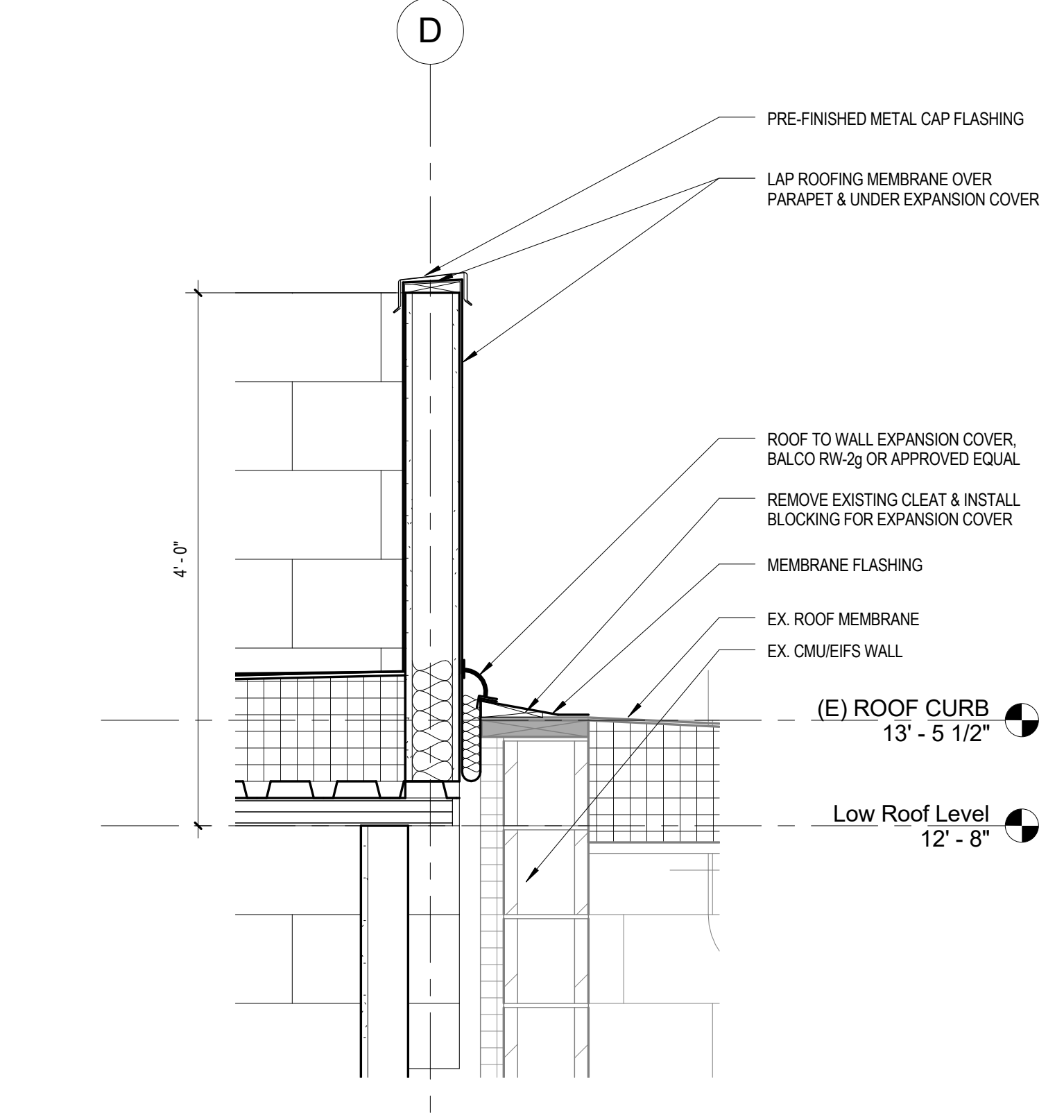

**4 ROOF DETAIL - SOUTH EXP. JOINT**  
 1" = 1'-0"

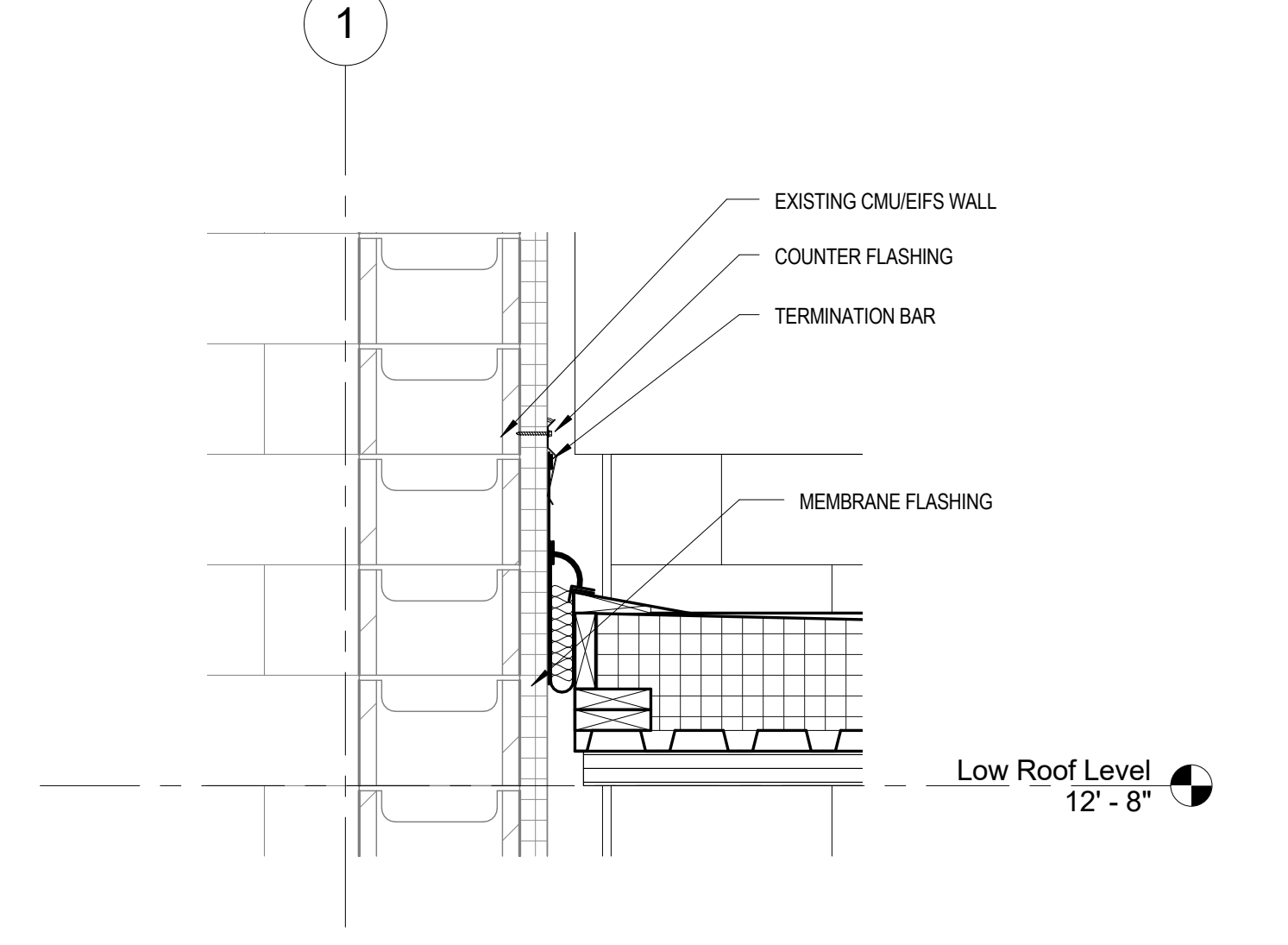

**5 ROOF DETAIL - WEST WALL STORAGE**  
 1" = 1'-0"

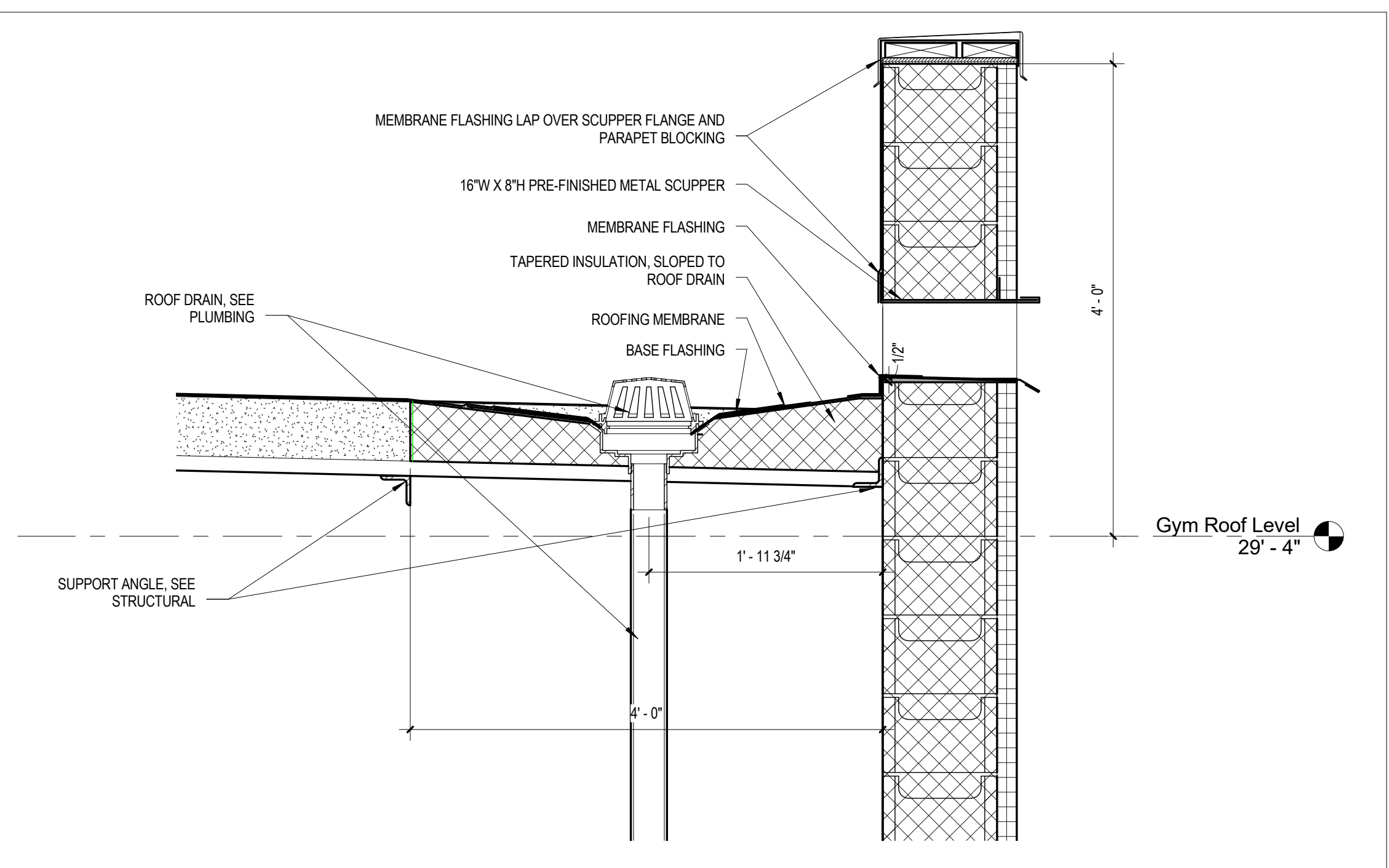

**1 ROOF DRAIN DETAIL**  
 1" = 1'-0"

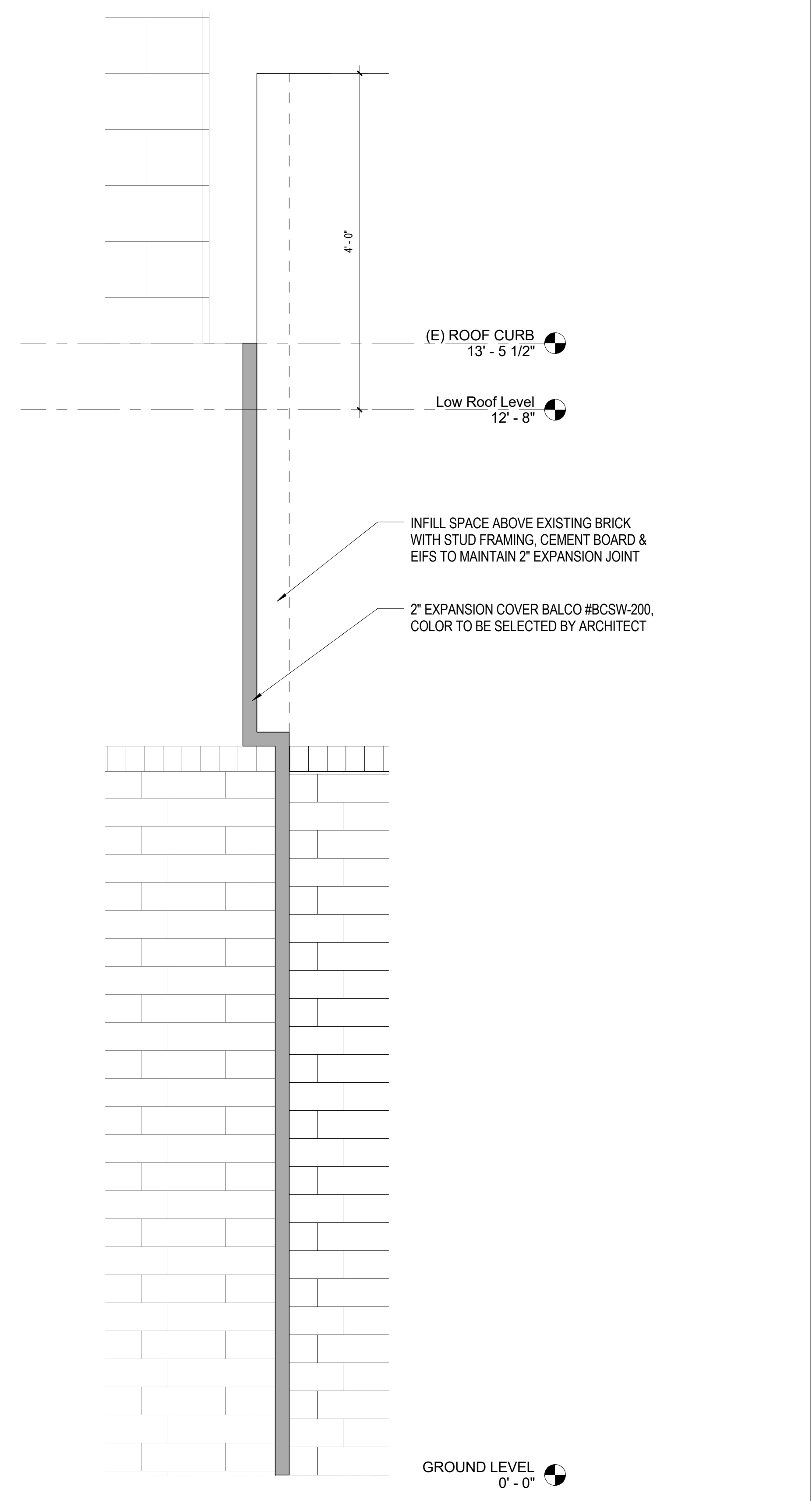

**2 EXPANSION JOINT DETAIL**  
 1" = 1'-0"



Revision Schedule	No.	Date	Description

Project Title:  
**CHASE COUNTY SCHOOL - GYM ADDITION**  
 520 EAST 9TH STREET  
 IMPERIAL, NEBRASKA 68033  
 CHASE COUNTY SCHOOLS

Sheet Title:  
**ROOF & EXPANSION JOINT DETAILS**  
 Completion: 100% CONSTRUCTION DOCUMENTS  
 Date Issued: MAY 16, 2016

Project: 203-003-15

Design	Drawing	Check
Designer	Author	Checker

Sheet No.  
**A-4.12**

04 CHANGE IN WALL SUBSTRATE

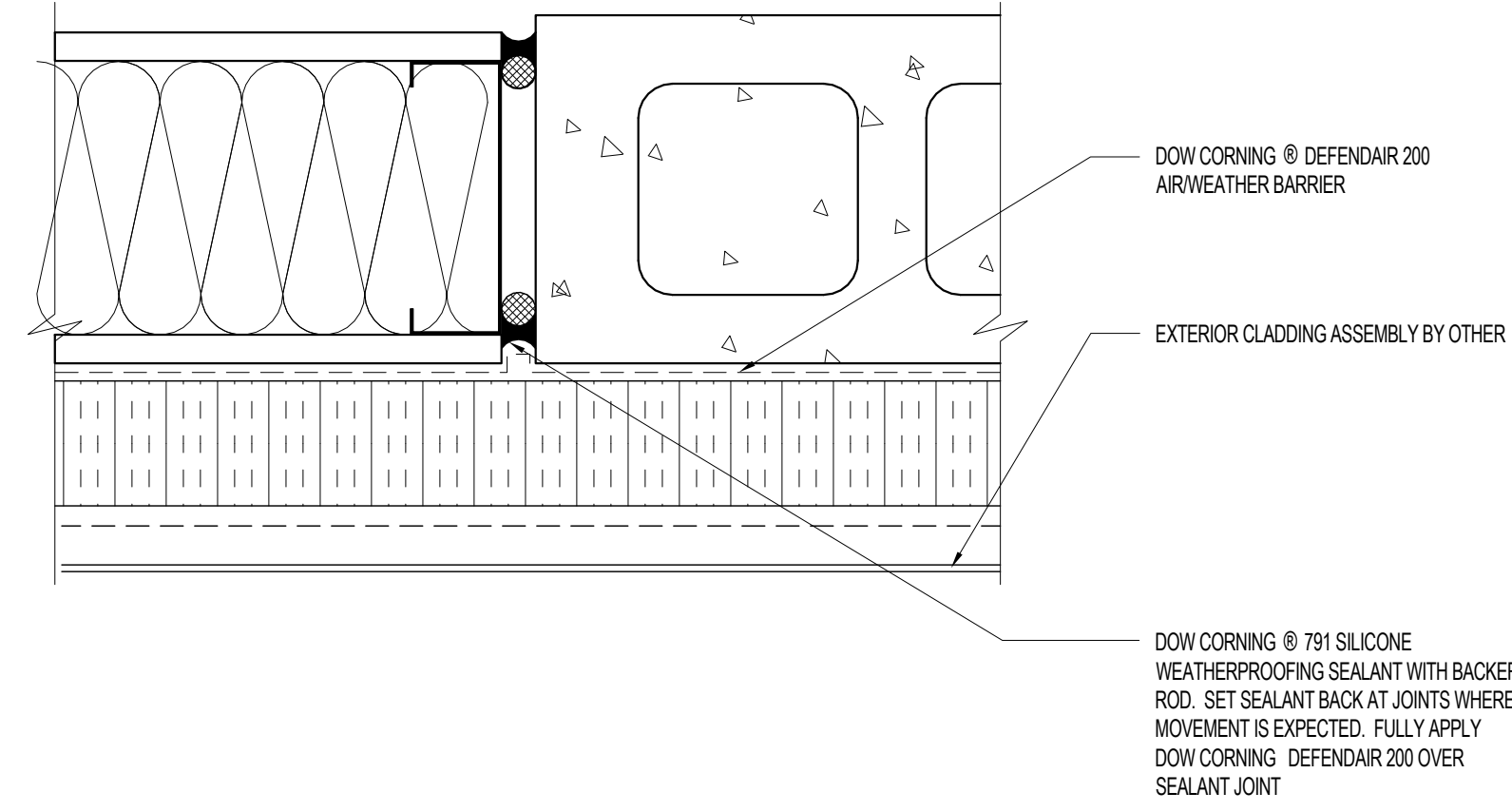

106 CMU WALL PENETRATION

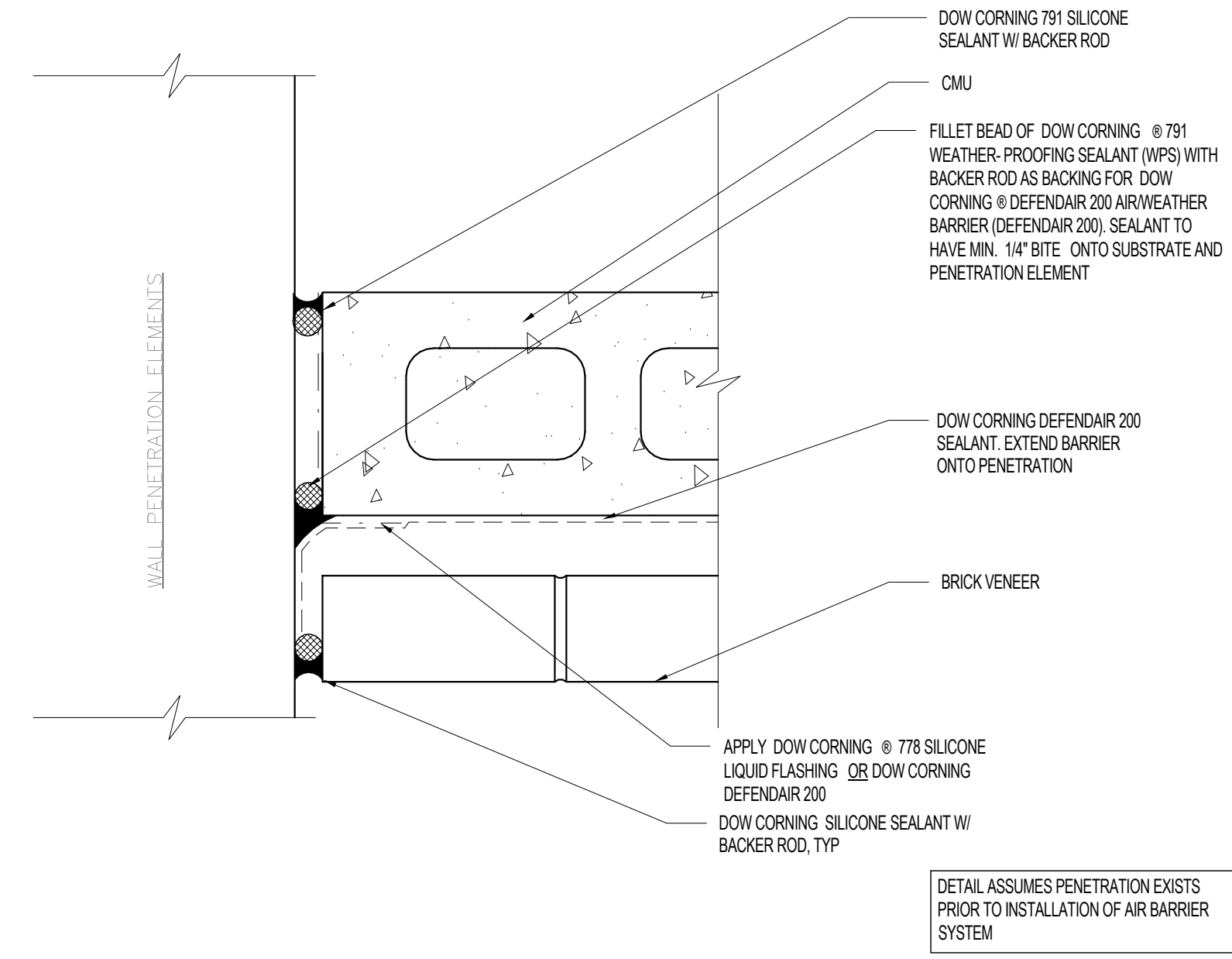

101a BRICK BASE WALL

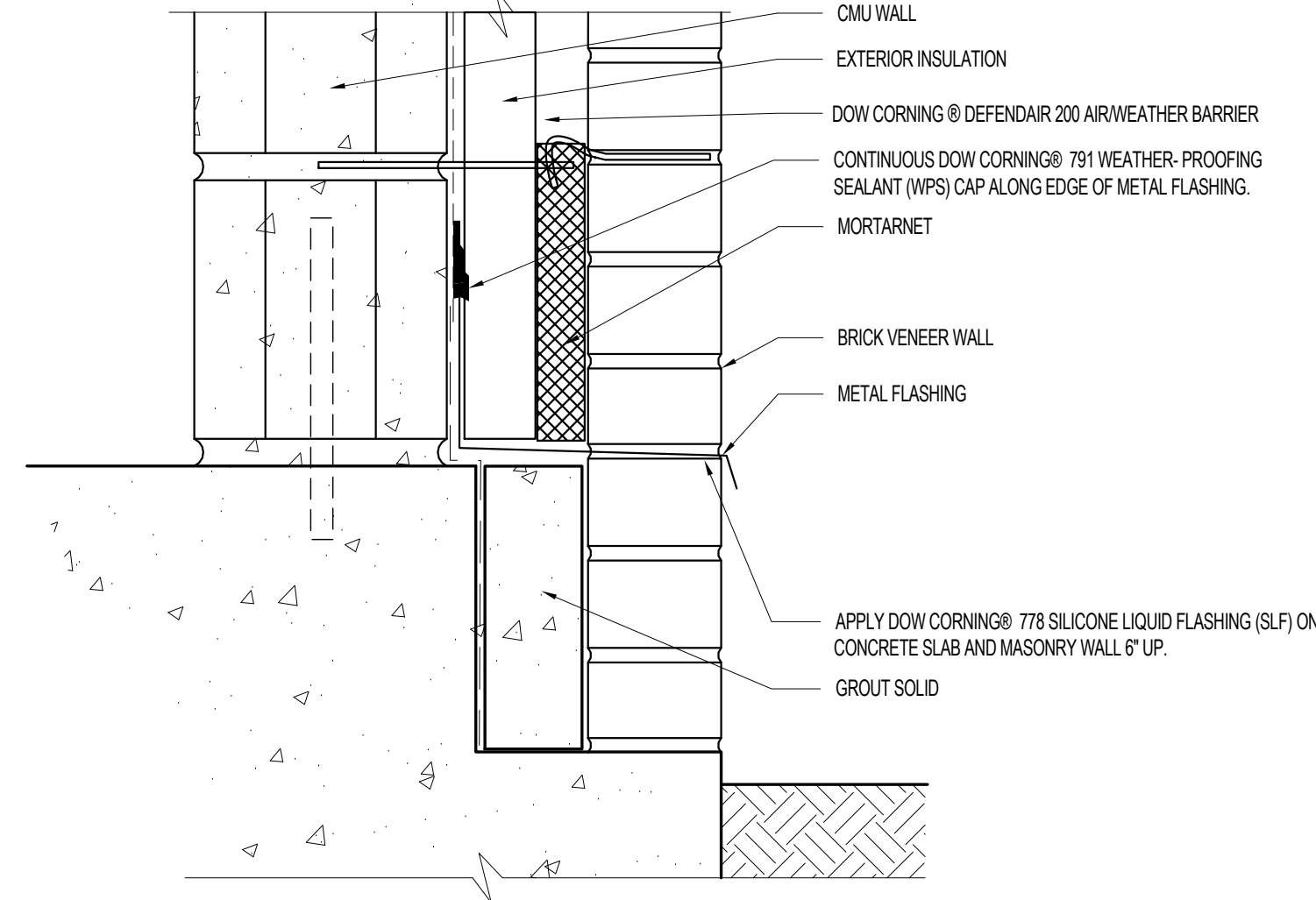

107a CMU WALL TO CURTAIN WALL

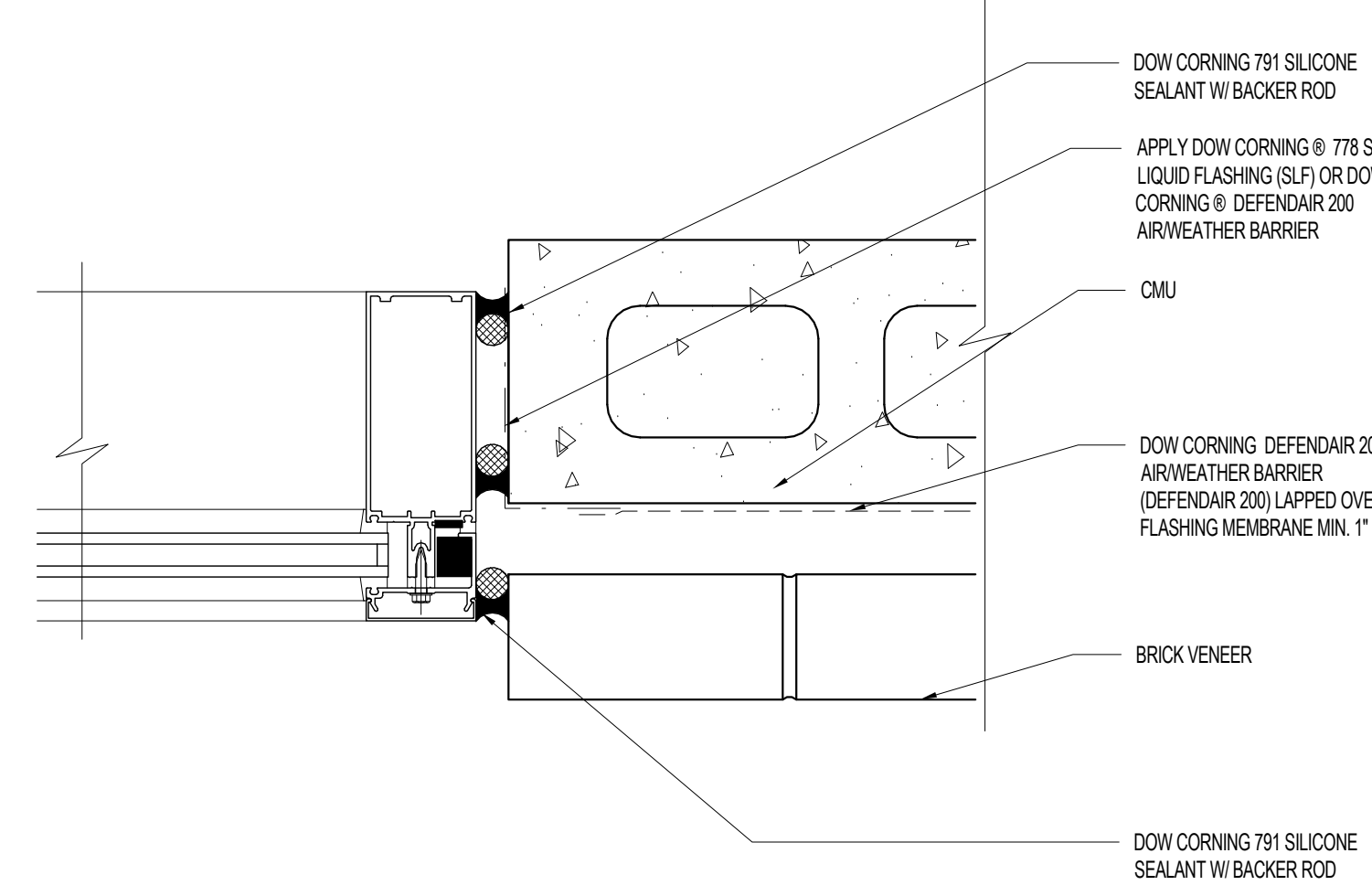

130 CMU WALL TO DOOR JAMB

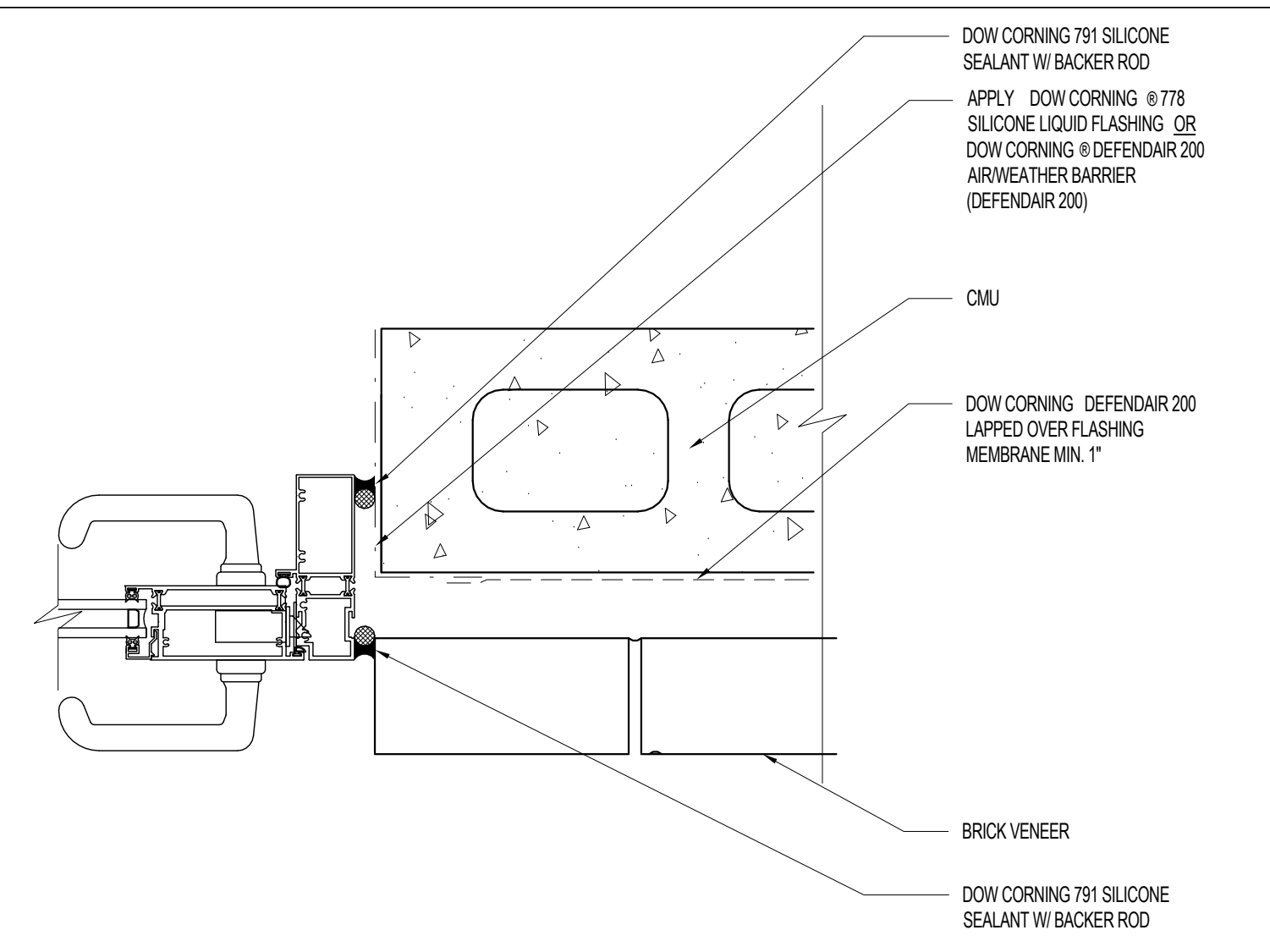

105 CMU WALL W/ OFFSET

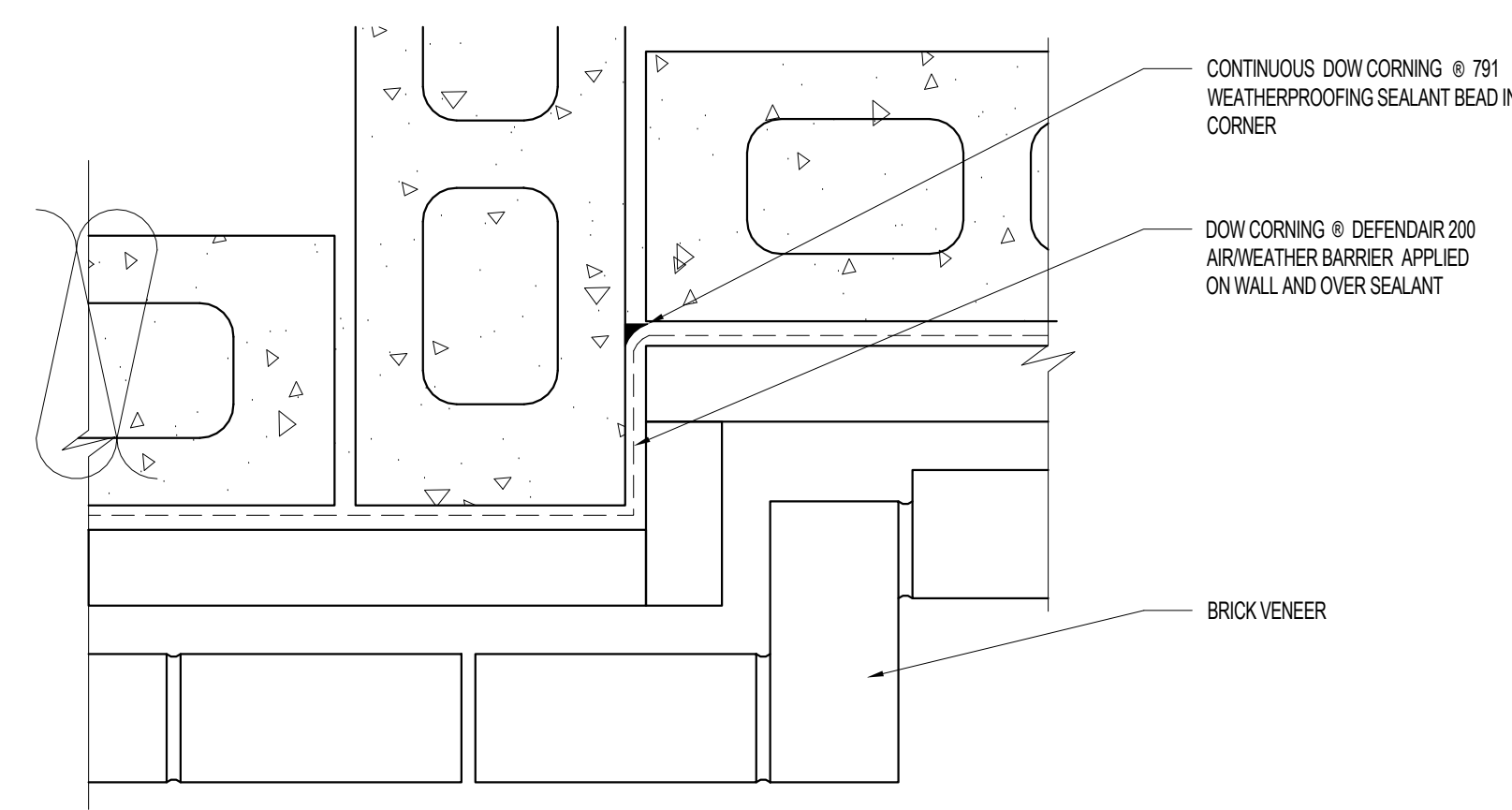

112 CMU WALL TO STOREFRONT

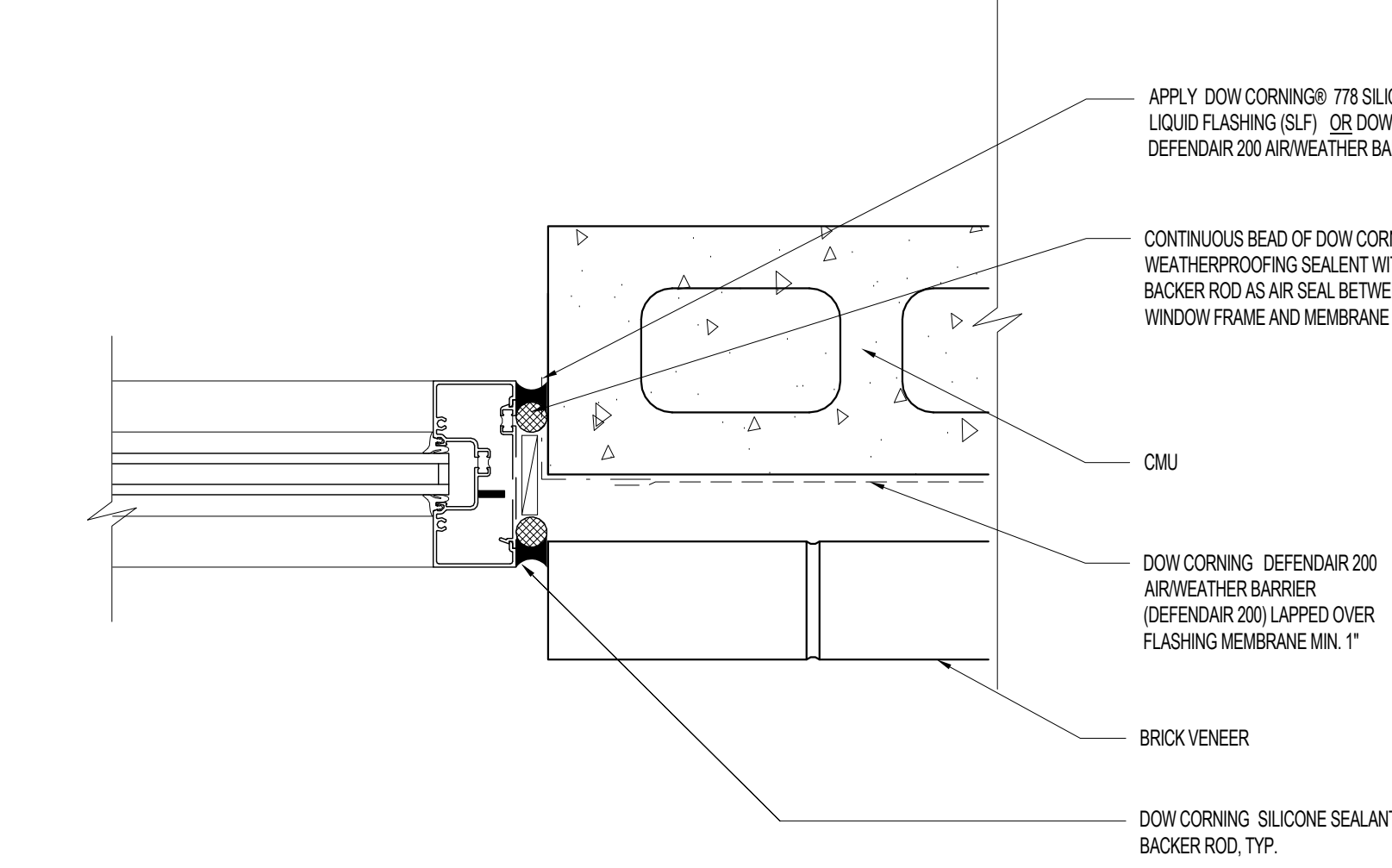

131 CMU WALL TO H.M. DOOR JAMB

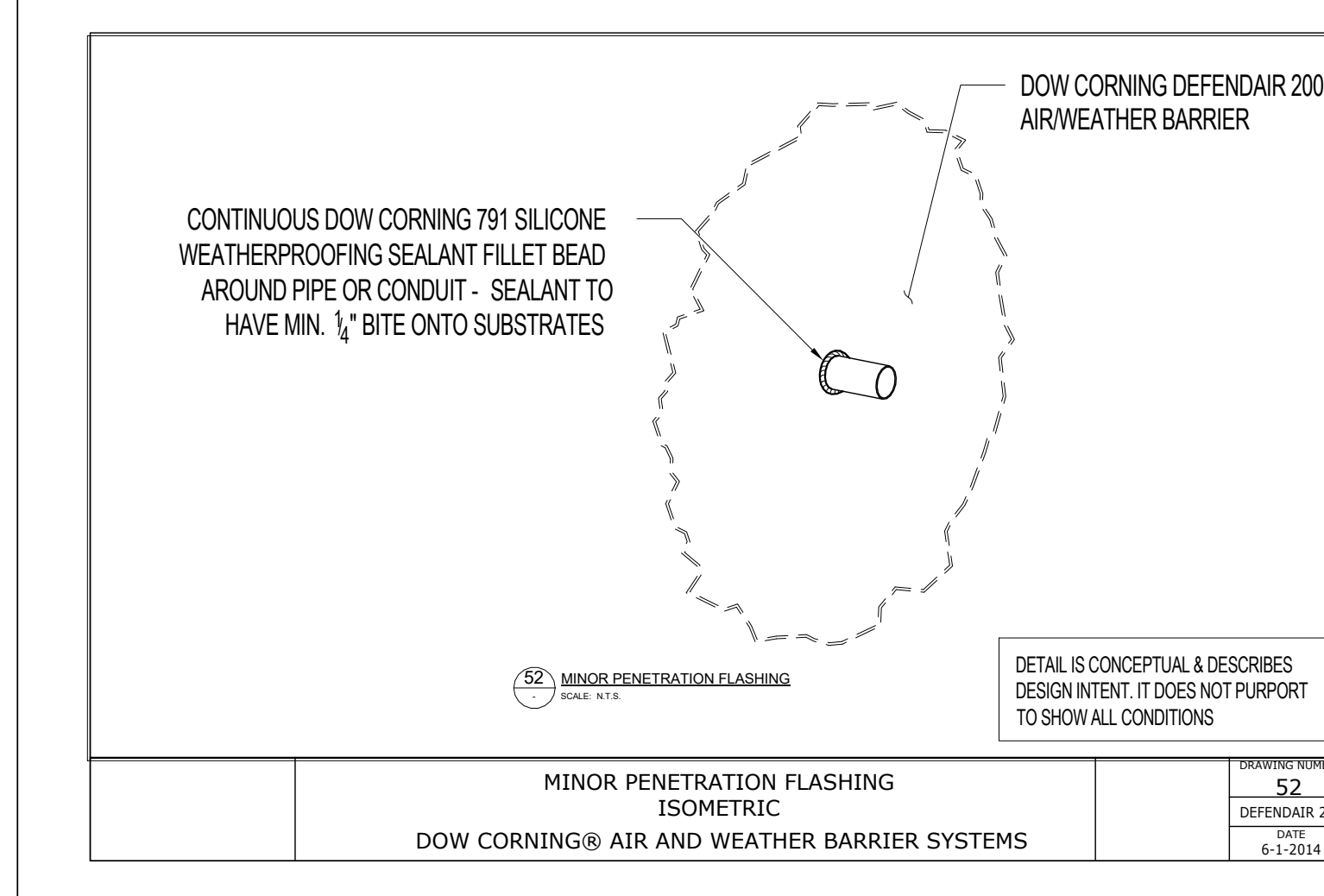
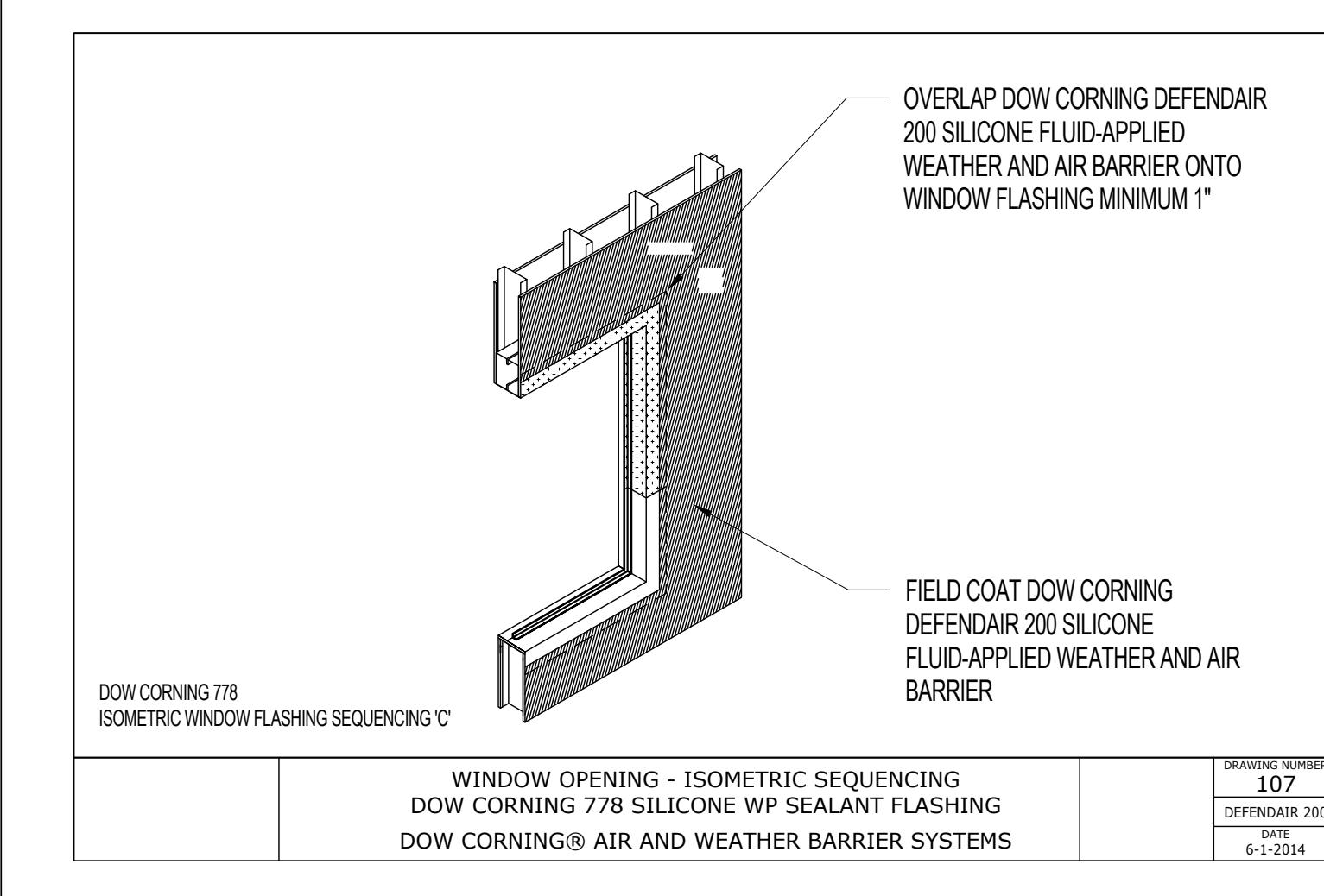
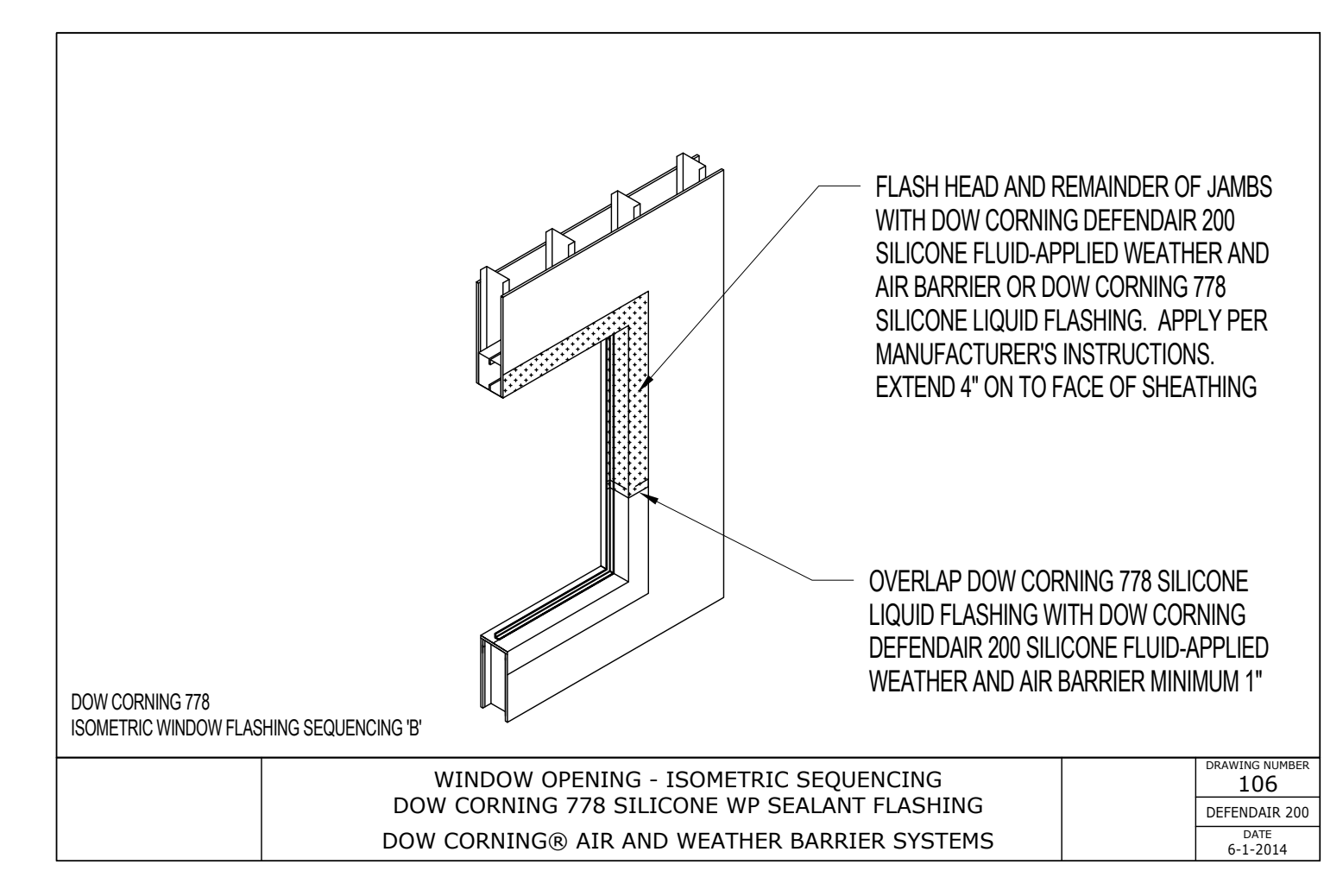
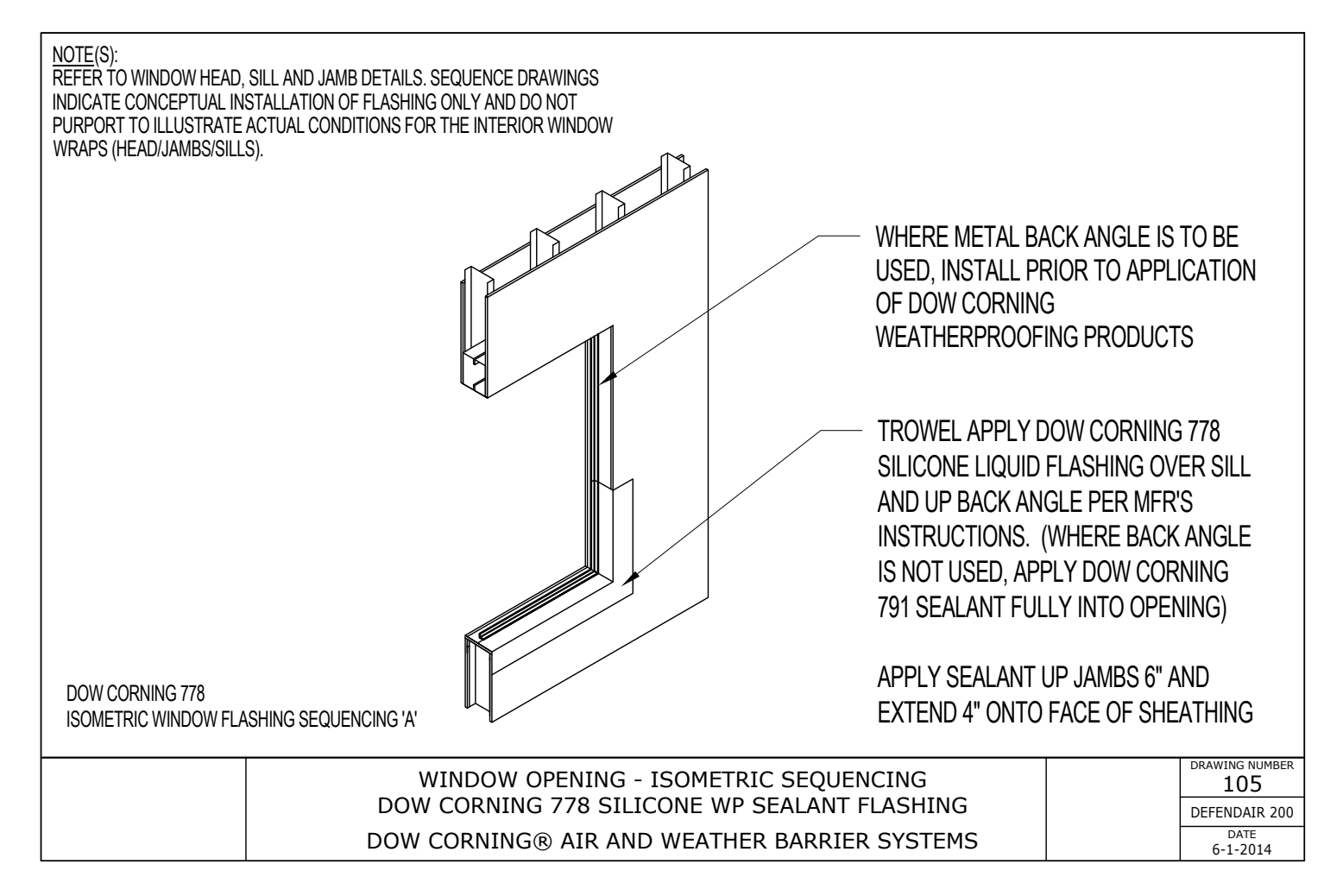
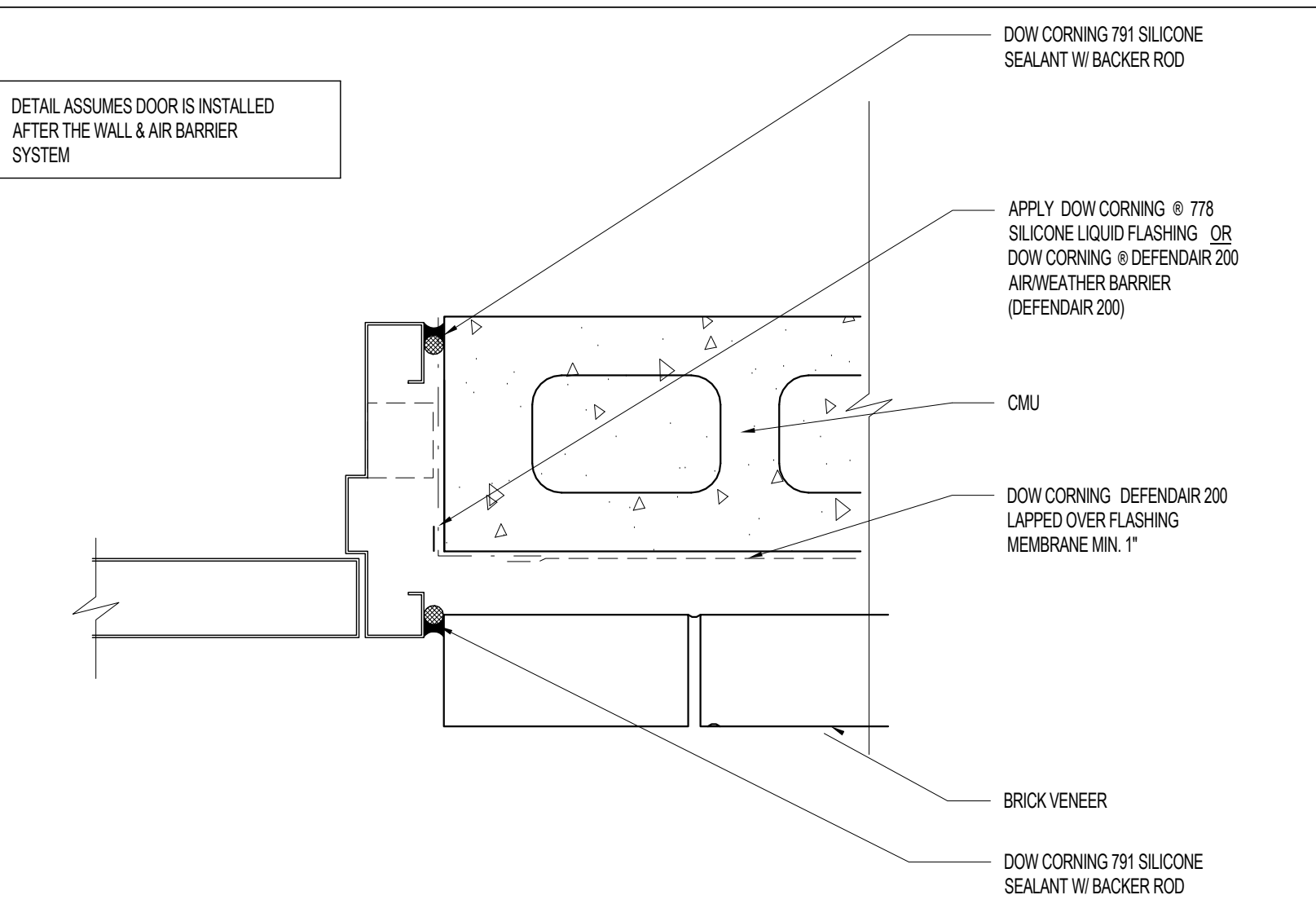

NOTE:  
 THESE DETAILS ARE PROVIDED ARE STANDARD DOW DEFENDAIR DETAILS AND ARE PROVIDED FOR CONVENIENCE OF THE CONTRACTOR. ADDITIONAL STANDARD DETAILS MAY BE REQUIRED FOR A COMPLETE INSTALLATION AND WARRANTY. THE INCLUSION OF THESE DETAILS DOES NOT RELIEVE THE CONTRACTOR'S RESPONSIBILITY TO FOLLOW ALL MANUFACTURER'S RECOMMENDED DETAILS & INSTRUCTIONS FOR A COMPLETE WARRANTED SYSTEM.



Project Title: CHASE COUNTY SCHOOL - GYM ADDITION  
 520 EAST 9TH STREET  
 IMPERIAL, NEBRASKA 68033  
 CHASE COUNTY SCHOOLS

Sheet Title: AIR & WEATHER BARRIER DETAILS  
 Completion: 100% CONSTRUCTION DOCUMENTS  
 Date Issued: MAY 16, 2016

Project: 203-003-15  
 Design Drawing Check  
 Designer Author Checker  
 Sheet No. A-4.20

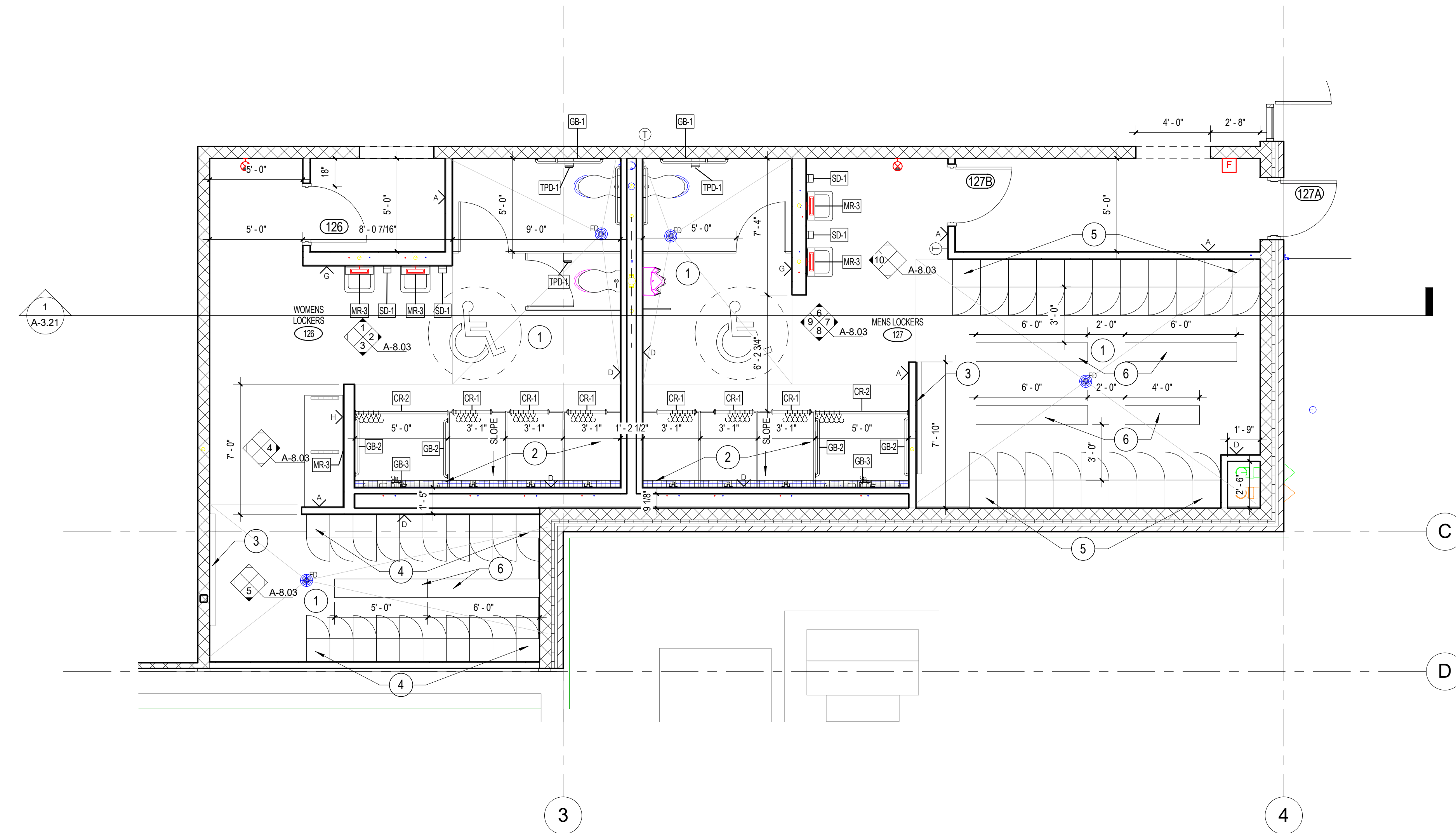

**KEYNOTE LEGEND**

- 1 SLOPE FLOOR TO FLOOR DRAIN.
- 2 SLOPE FLOOR TO TRENCH DRAIN ALONG WALL.
- 3 4 H X 6' W MARKER BOARD WITH MARKER TRAY.
- 4 15' X 15' X 72"H DOUBLE TIER ATHLETIC LOCKERS.
- 5 18' X 18' X 72"H DOUBLE TIER ATHLETIC LOCKERS.
- 6 LOCKER ROOM BENCHES



Revision Schedule	Description
No.   Date	

Project Title: CHASE COUNTY SCHOOL - GYM ADDITION  
 520 EAST 9TH STREET  
 IMPERIAL, NEBRASKA 68033  
 CHASE COUNTY SCHOOLS

ENLARGED PLANS  
 Completion: 100% CONSTRUCTION DOCUMENTS  
 Date Issued: MAY 16, 2016

Project: 203-003-15

Design: JDW  
 Drawing: JDS  
 Check: JDW

Sheet No. A-5.00

**1** 1/4" = 1'-0" ENLARGED PLAN - WOMEN'S & MEN'S LOCKERS

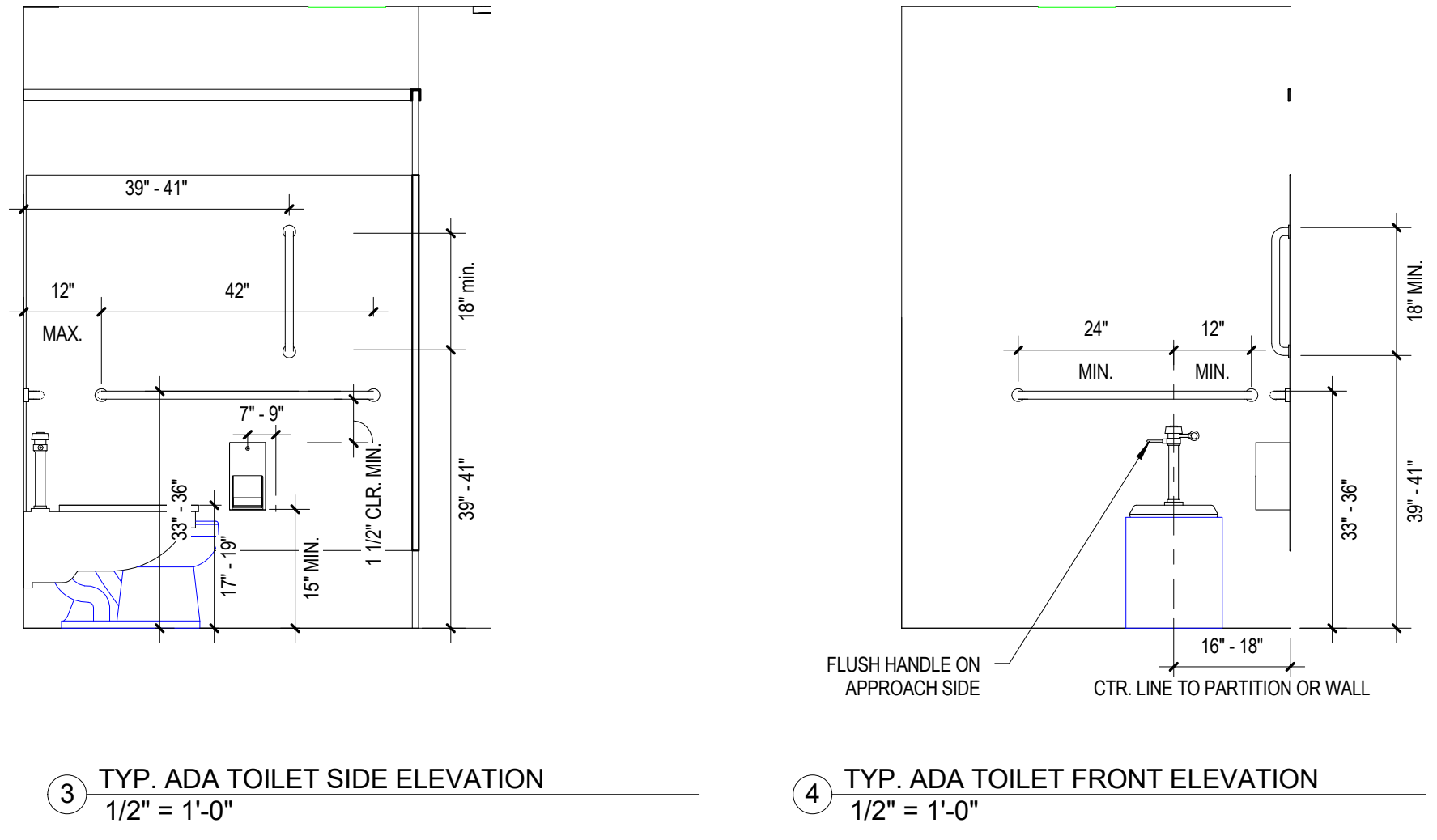

3 TYP. ADA TOILET SIDE ELEVATION  
 1/2" = 1'-0"

4 TYP. ADA TOILET FRONT ELEVATION  
 1/2" = 1'-0"

ITEM	DESCRIPTION	MOUNTING HEIGHTS			BASIS OF DESIGN	PROVIDED BY/ INSTALLED BY
		STD.	H.C.	REMARKS		
BS-1	BABY CHANGING STATION				BRADLEY #9611	CONTRACTOR
CR-1	CURTAIN ROD				BRADLEY #9539	CONTRACTOR
GB-1	42" SIDE GRAB BAR, 36" REAR GRAB BAR, 18" VERTICAL GRAB BAR	35"		TO CENTER	BRADLEY 812 SERIES	CONTRACTOR
GB-2	36" GRAB BAR	35"		TO CENTER	BRADLEY 812 SERIES	CONTRACTOR
GB-3	48" GRAB BAR	35"		TO CENTER	BRADLEY 812 SERIES	CONTRACTOR
GB-4	24" GRAB BAR	35"		TO CENTER	BRADLEY 812 SERIES	CONTRACTOR
HD-1	WARM-AIR DRYER				EXCEL XL-GR	CONTRACTOR
MR-1	18" X 30" MIRROR	40"		TO BOTTOM	BRADLEY #747	CONTRACTOR
MR-2	18" X 36" MIRROR W/ SHELF	40"		TO BOTTOM	BRADLEY #747W LOW	CONTRACTOR
MR-3	60" X 36" MIRROR	40"		TO BOTTOM	BRADLEY #7805-1836	CONTRACTOR
PT-1	PAPER TOWEL DISPENSER					OWNER
SC-1	SHOWER CURTAIN					CONTRACTOR
SD-1	SOAP DISPENSER					OWNER
SP-1	40" X 42" HDPE SHOWER PARTITION					CONTRACTOR
SP-2	60" X 42" HDPE ADA SHOWER PARTITION					CONTRACTOR
TPD-1	TOILET PAPER DISPENSER					OWNER

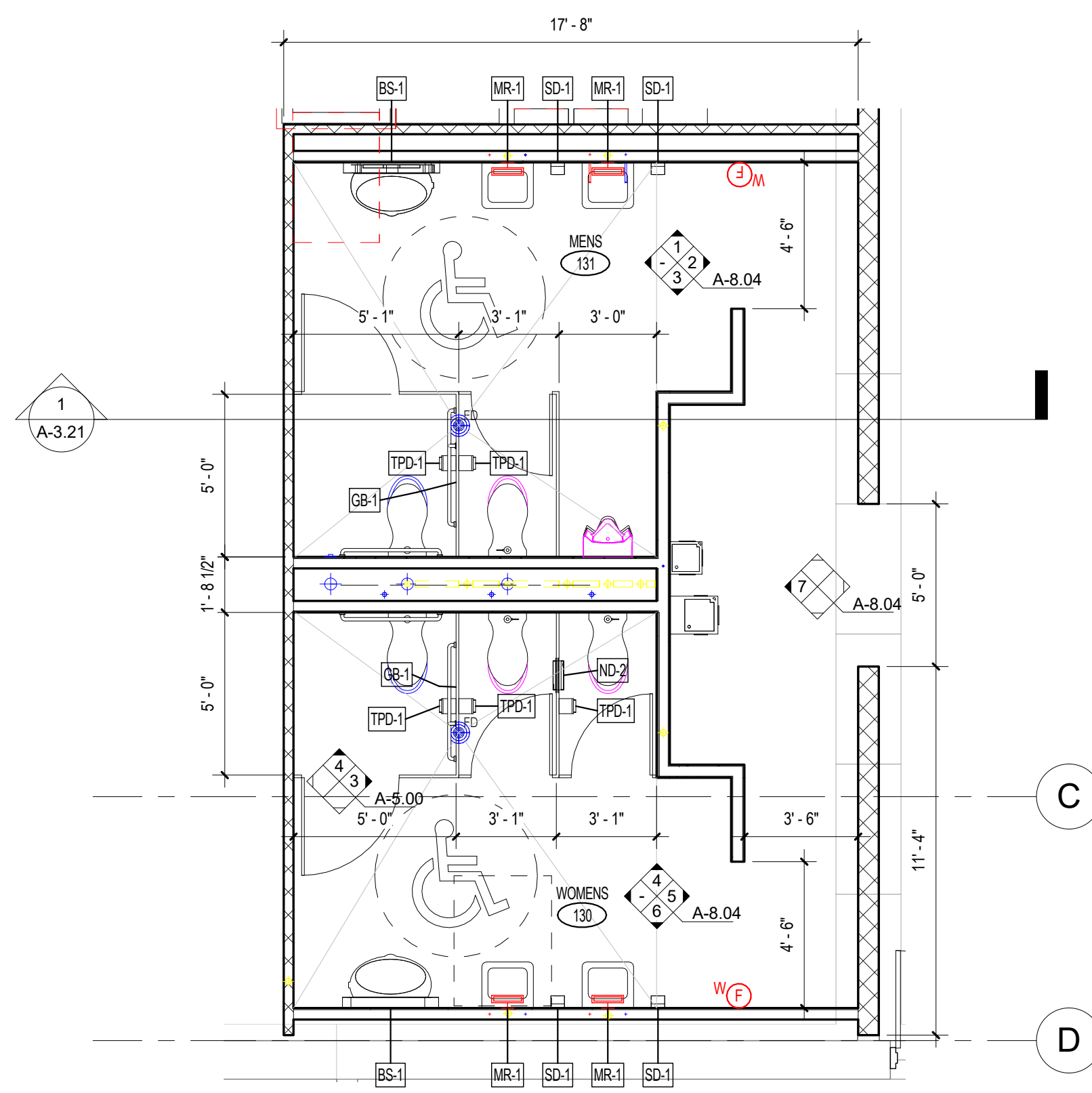

**2** 1/4" = 1'-0" ENLARGED PLAN - WOMEN'S & MEN'S RESTROOMS

Mark	Pair	Door						Frame		Fire Rating	Hardware Set	Schedule Notes
		Width	Height	Type	Material	Thickness	Glass	Type	Frame Material			
101A	Yes	3'-0"	7'-0"	D4	HM	0'-1 3/4"	CTG	F3	HM	90 MINUTE	3A	
101B	No	3'-0"	7'-0"	D5	AL	0'-1 3/4"	TTIG	F4	AL	-	2	PROVIDE AUTOMATIC OPERATOR AND PUSH BUTTONS EACH SIDE
101C	Yes	6'-0"	7'-0"	D6	AL	0'-1 3/4"	TTIG	F4	AL	-	1	
104A	Yes	3'-0"	7'-0"	D4	HM	0'-1 3/4"	CTG	F3	HM	-	3	
104B	Yes	3'-0"	7'-0"	D4	HM	0'-1 3/4"	CTG	F3	HM	-	5	
107A	Yes	3'-0"	7'-0"	D4	HM	0'-1 3/4"	CTG	F3	HM	-	3	
107B	No	3'-6"	7'-0"	D3	HM	0'-1 3/4"	CTG	F2	HM	-	4	
107C	Yes	3'-0"	7'-0"	D4	HM	0'-1 3/4"	CTG	F3	HM	-	5	
126	No	3'-0"	7'-0"	D1	HM	0'-1 3/4"	-	F1	HM	-	7	
127A	No	3'-0"	7'-0"	D1	HM	0'-1 3/4"	-	F2	HM	-	6	
127B	No	3'-0"	7'-0"	D1	HM	0'-1 3/4"	-	F1	HM	-	7	
128A	Yes	3'-0"	7'-0"	D2	HM	0'-1 3/4"	-	F3	HM	-	8	
128B	Yes	3'-0"	7'-0"	D2	HM	0'-1 3/4"	-	F3	HM	-	8	

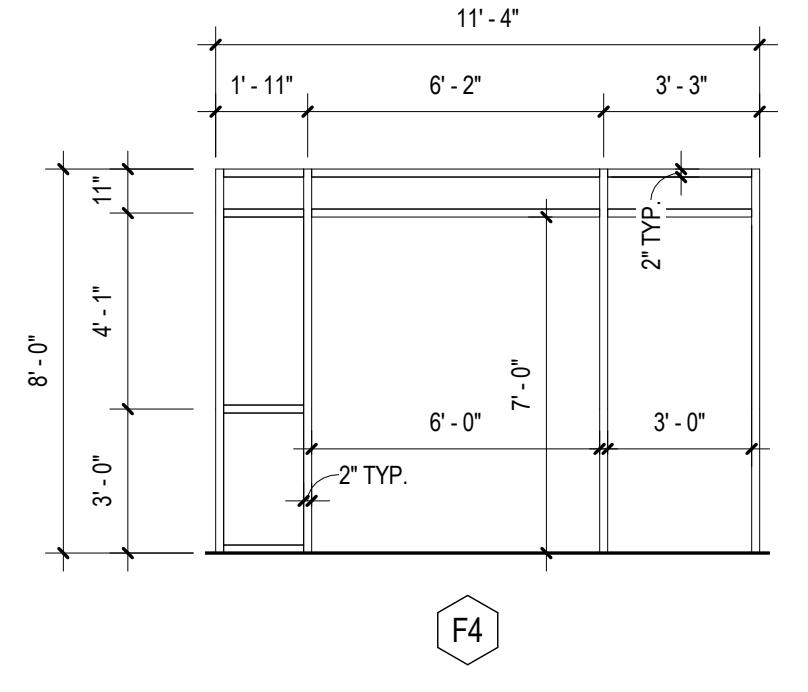
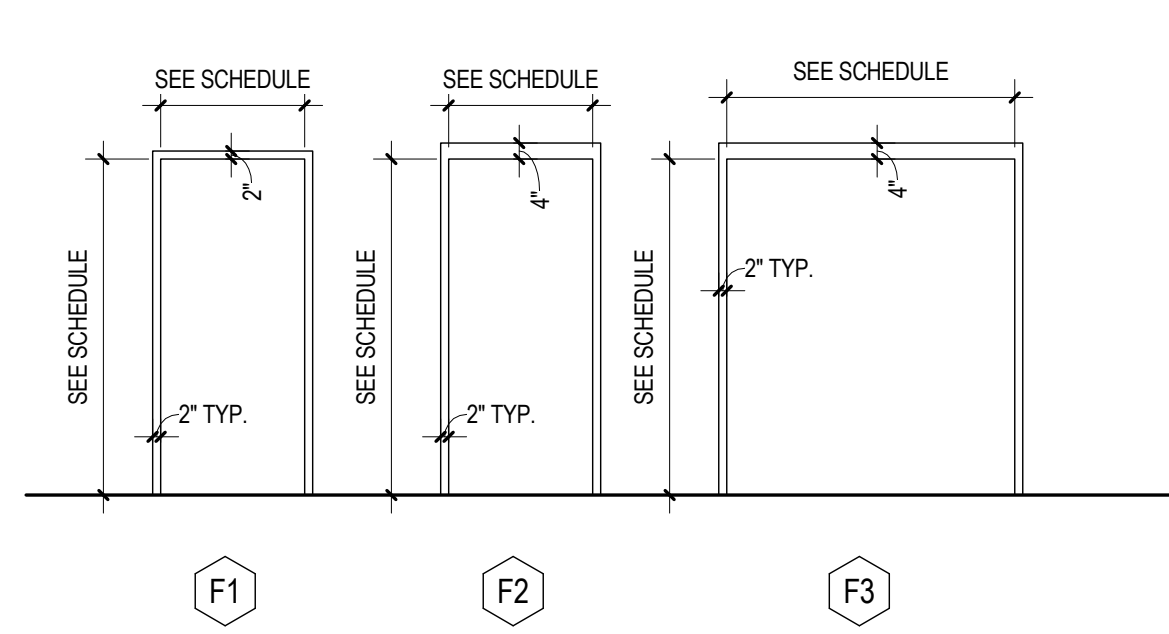
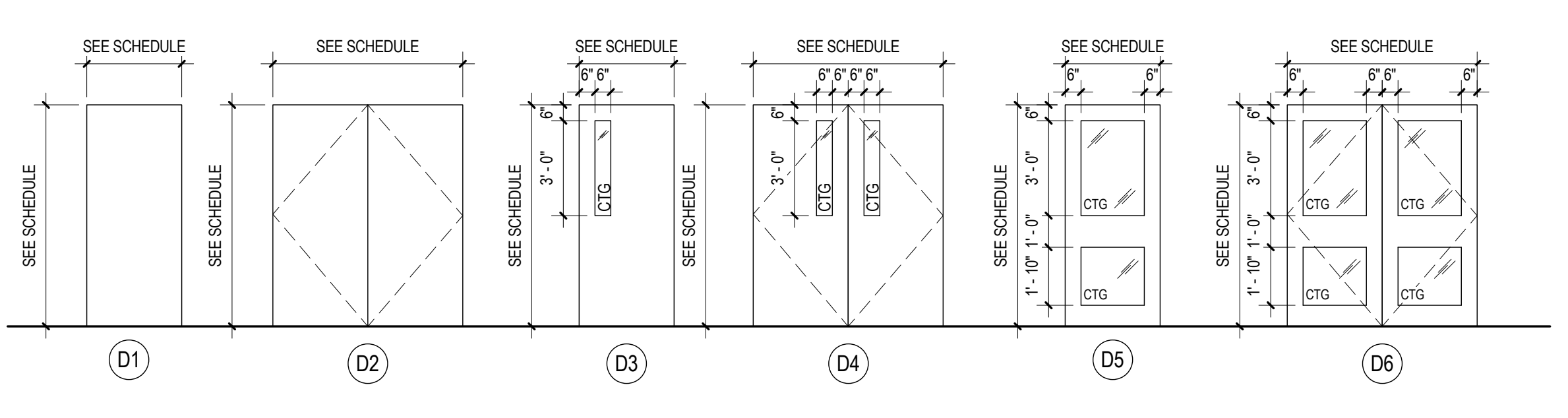

**1 DOOR TYPES**  
 1/4" = 1'-0"

**2 FRAME TYPES**  
 1/4" = 1'-0"

**3 STOREFRONT ELEVATION**  
 1/4" = 1'-0"

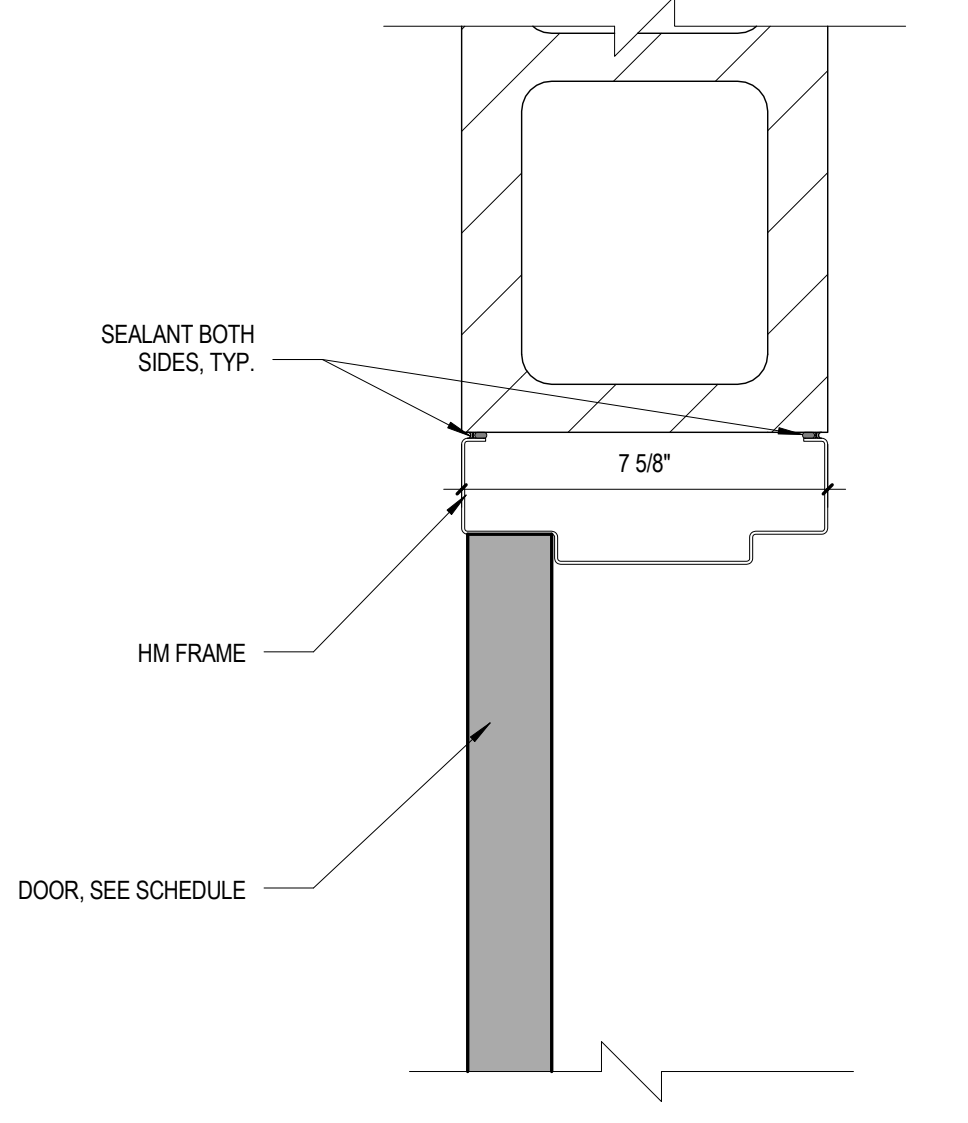
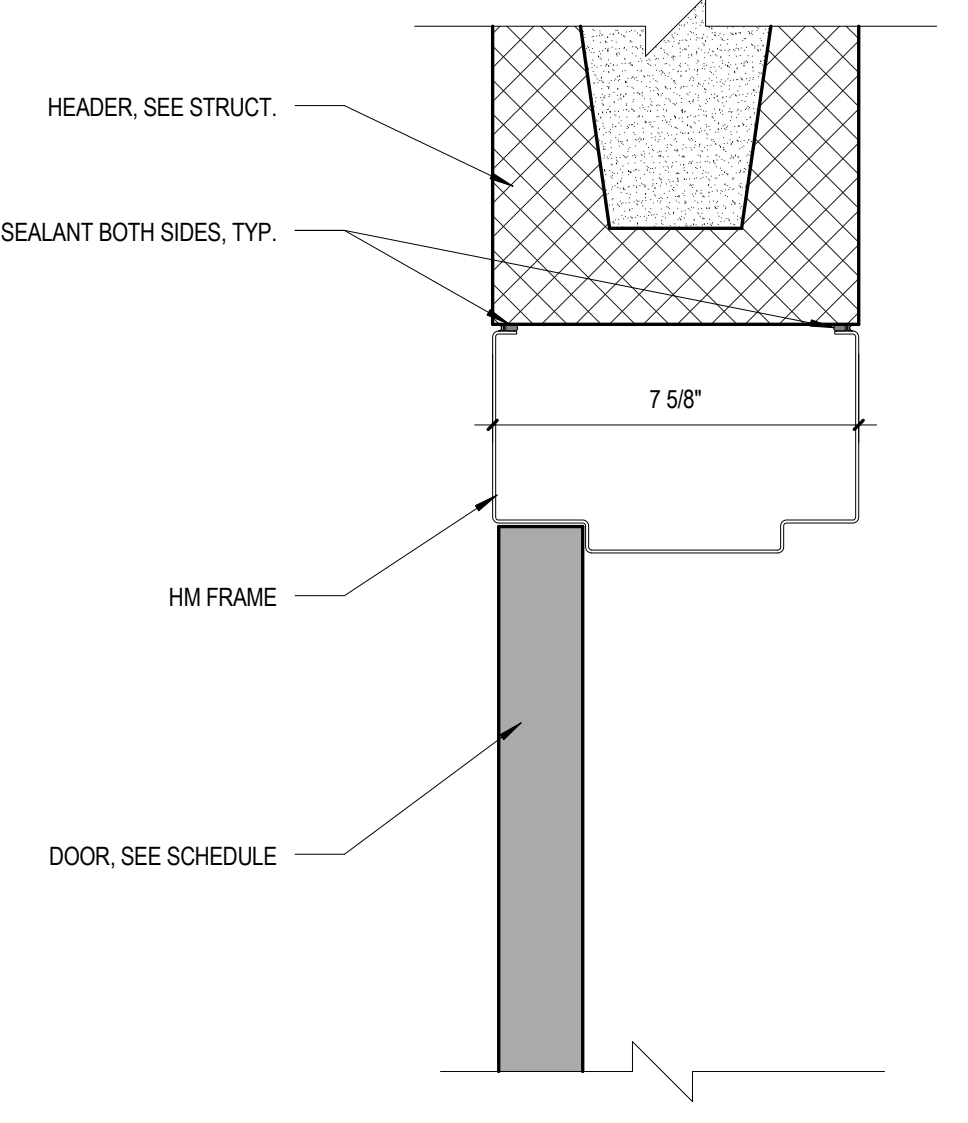
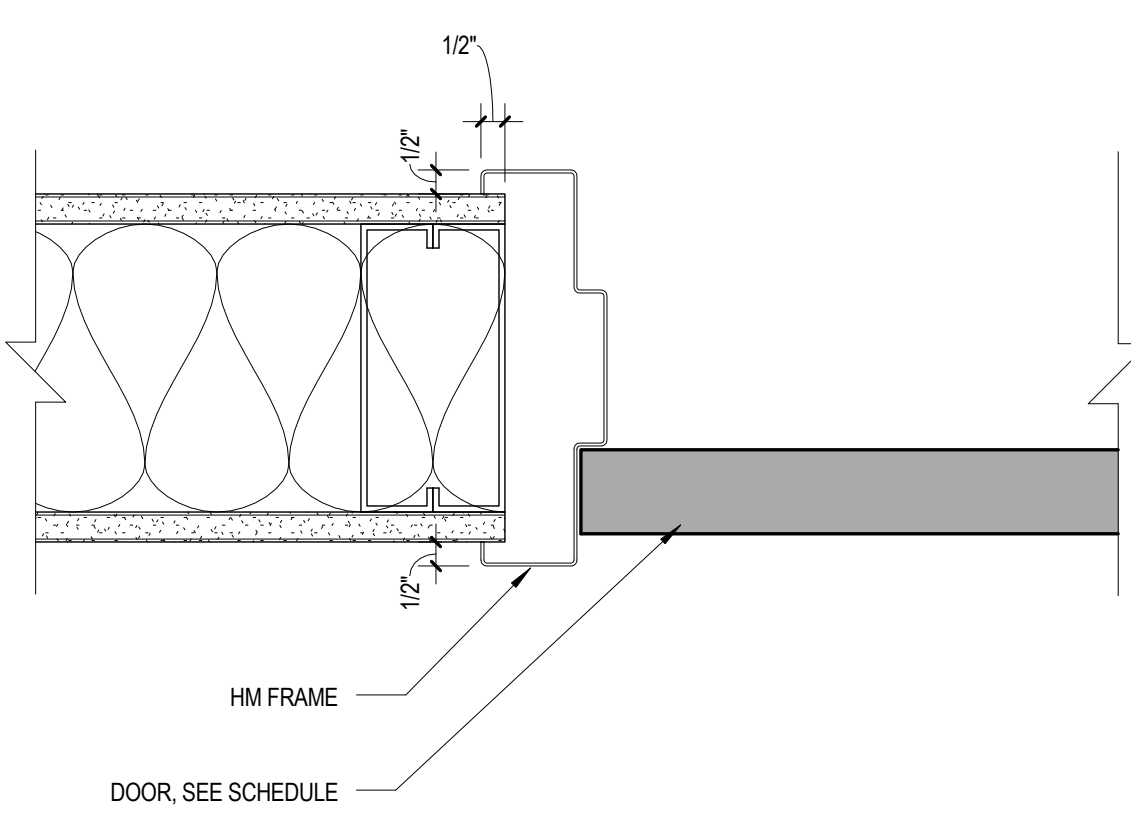
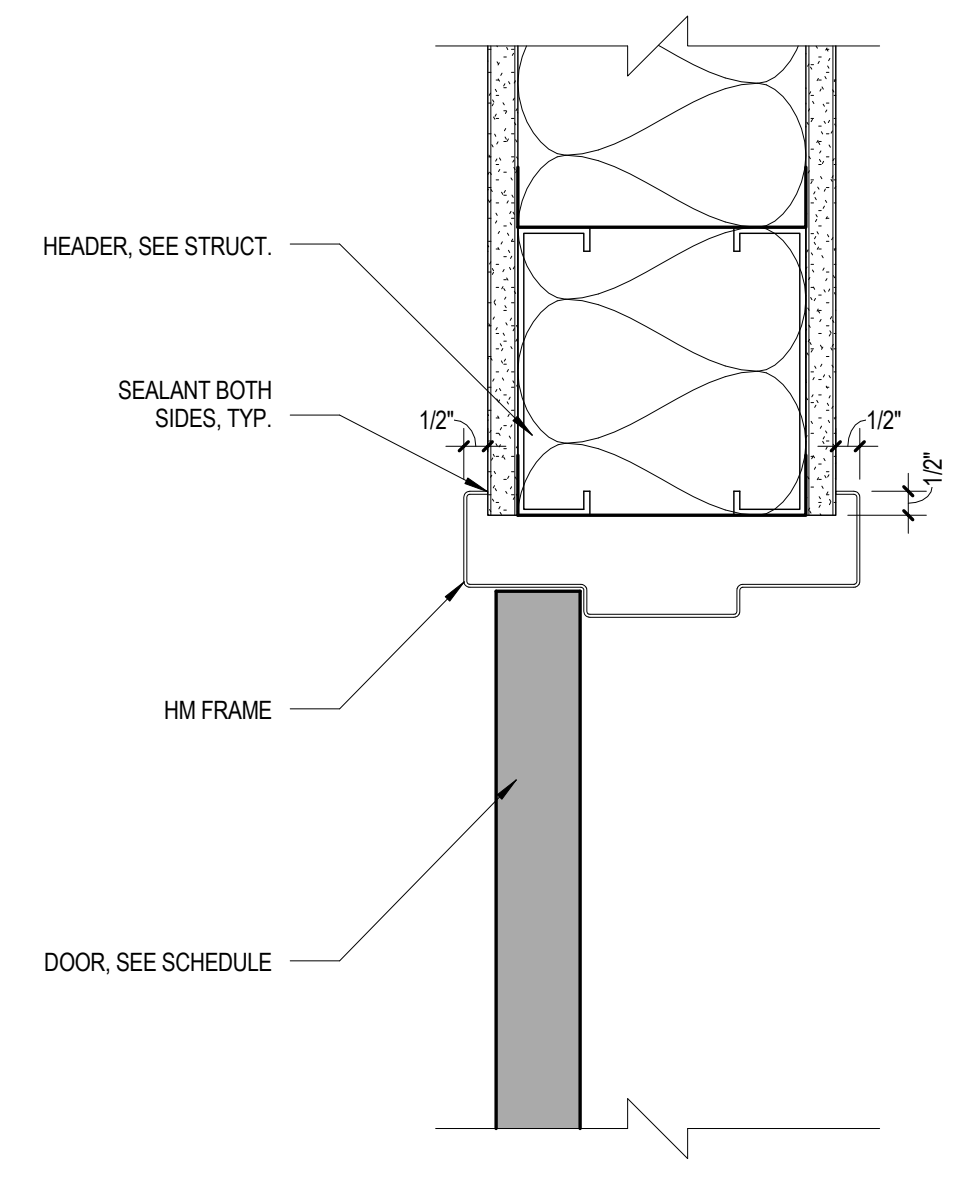

**HM DOOR HEAD DETAIL @ STUD WALL**  
 3" = 1'-0"

**HM DOOR JAMB DETAIL @ STUD WALL**  
 3" = 1'-0"

**HM DOOR HEAD DETAIL @ 8" CMU**  
 3" = 1'-0"

**HM DOOR JAMB DETAIL @ 8" CMU**  
 3" = 1'-0"

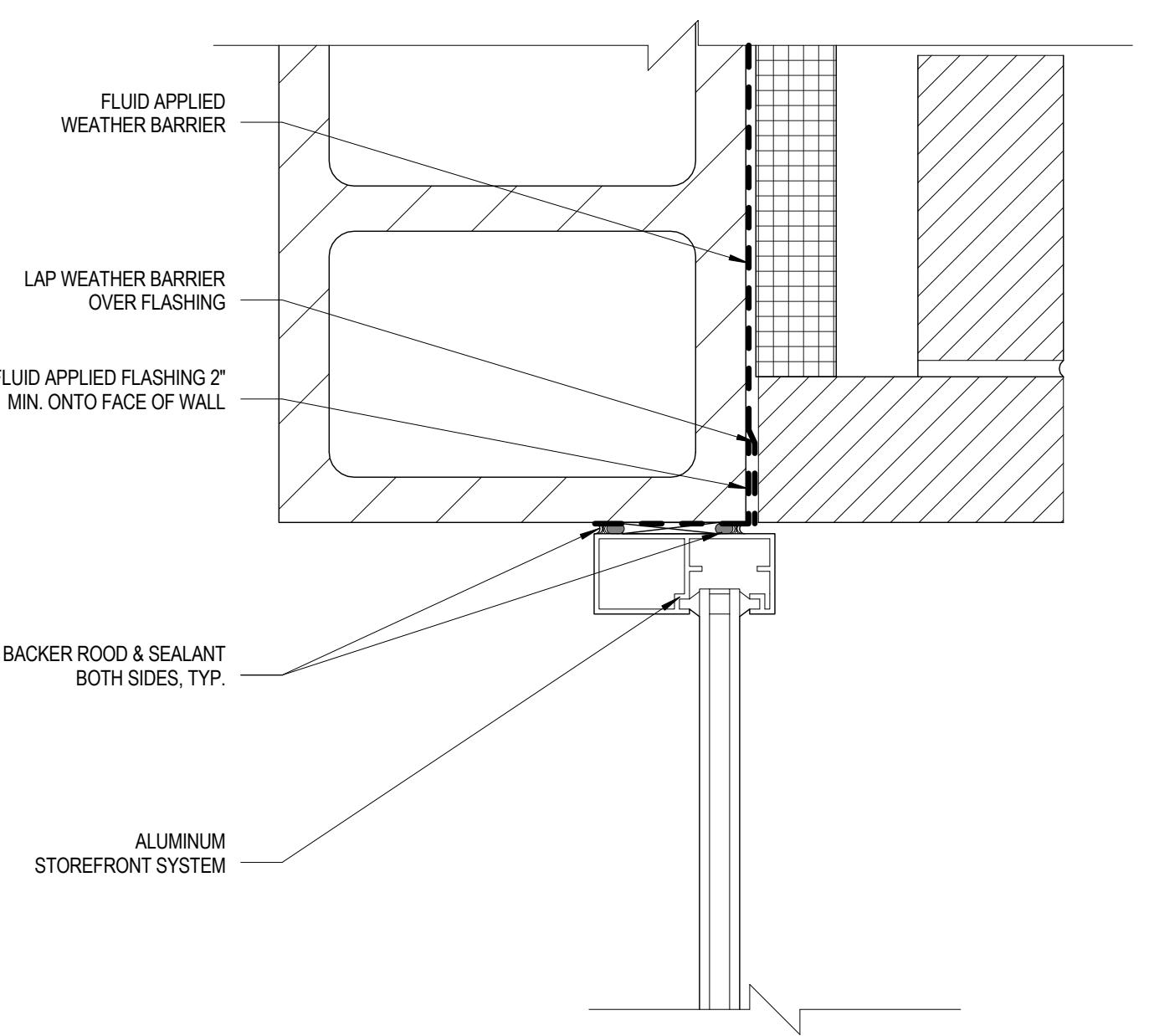
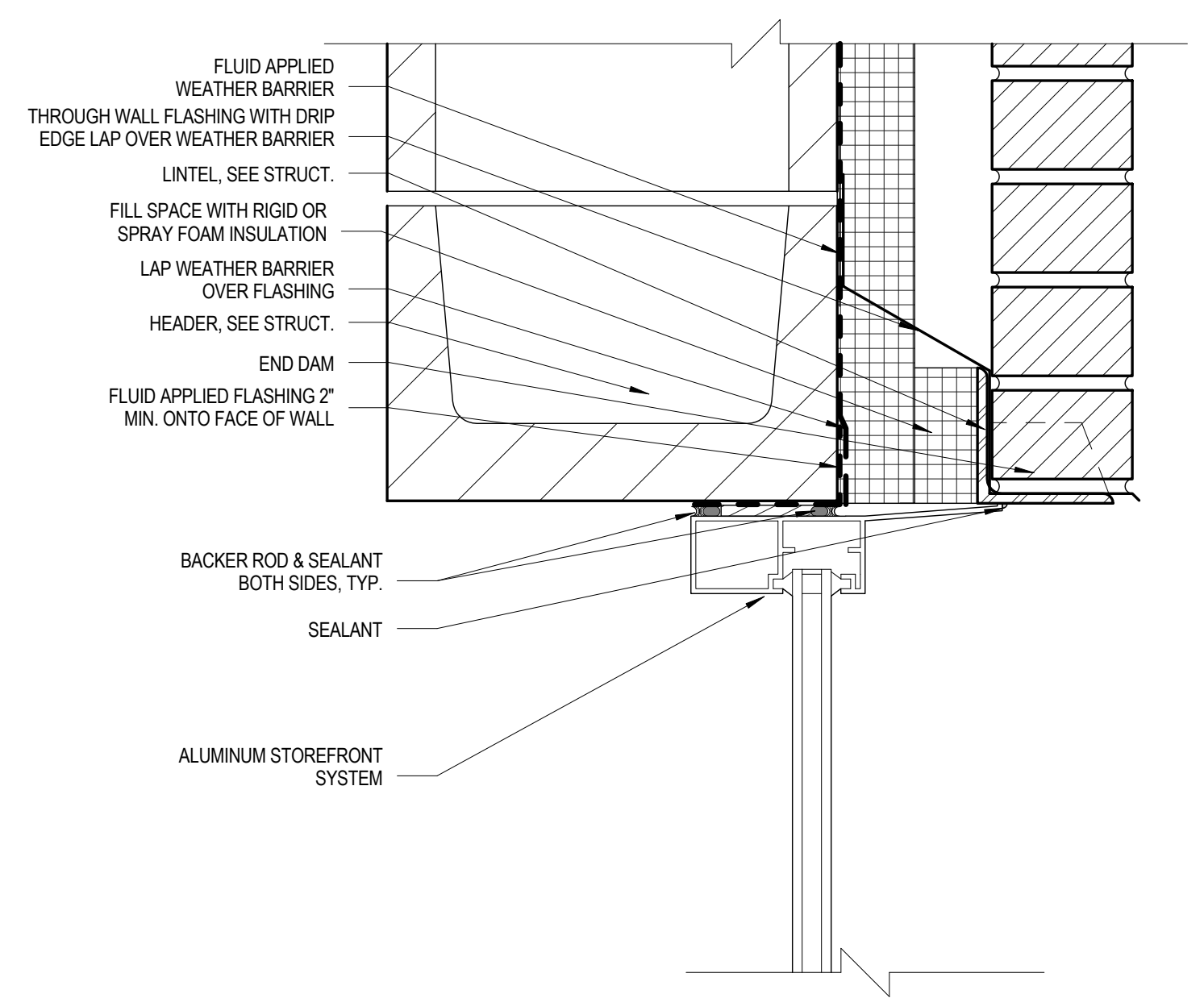
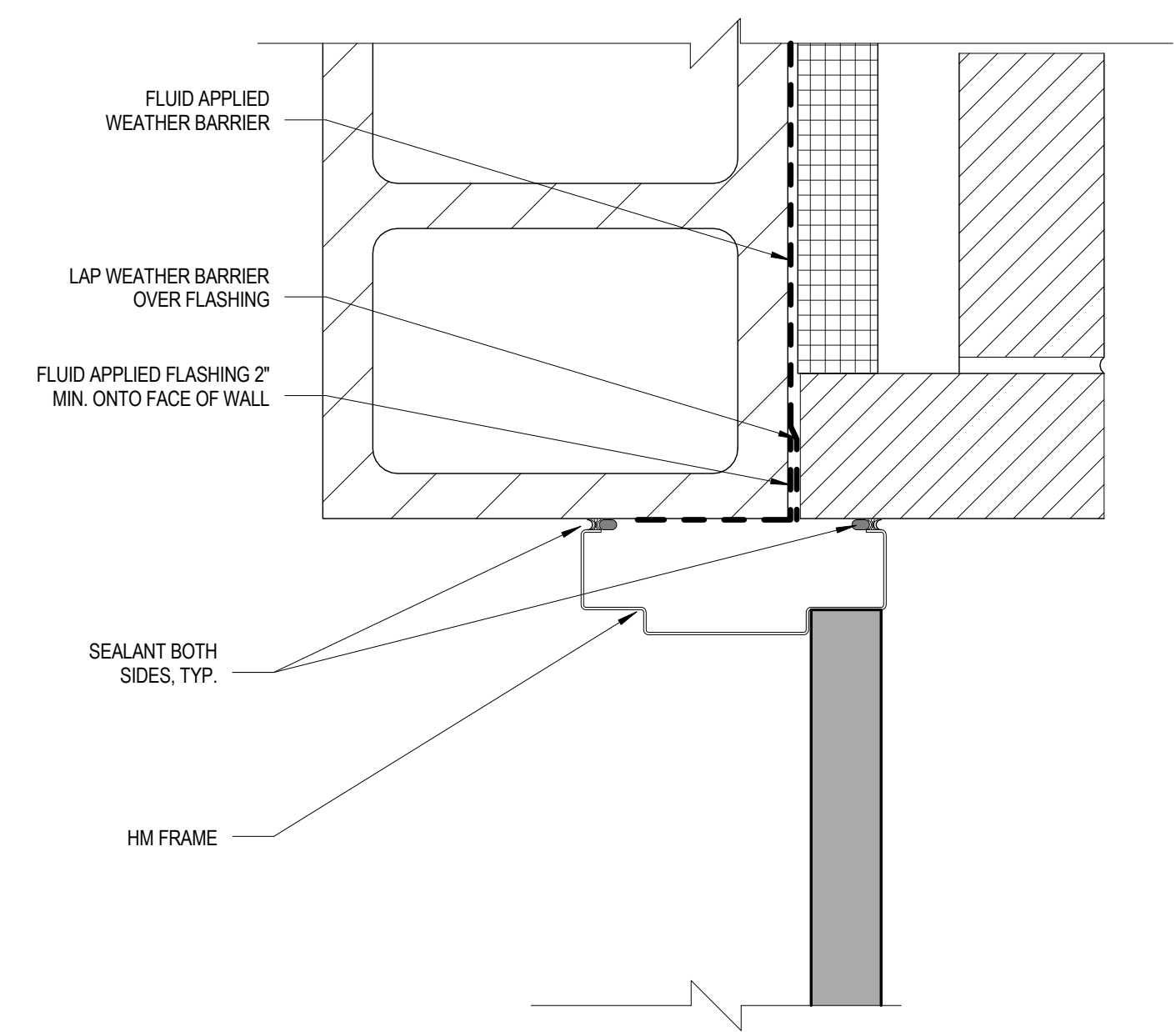
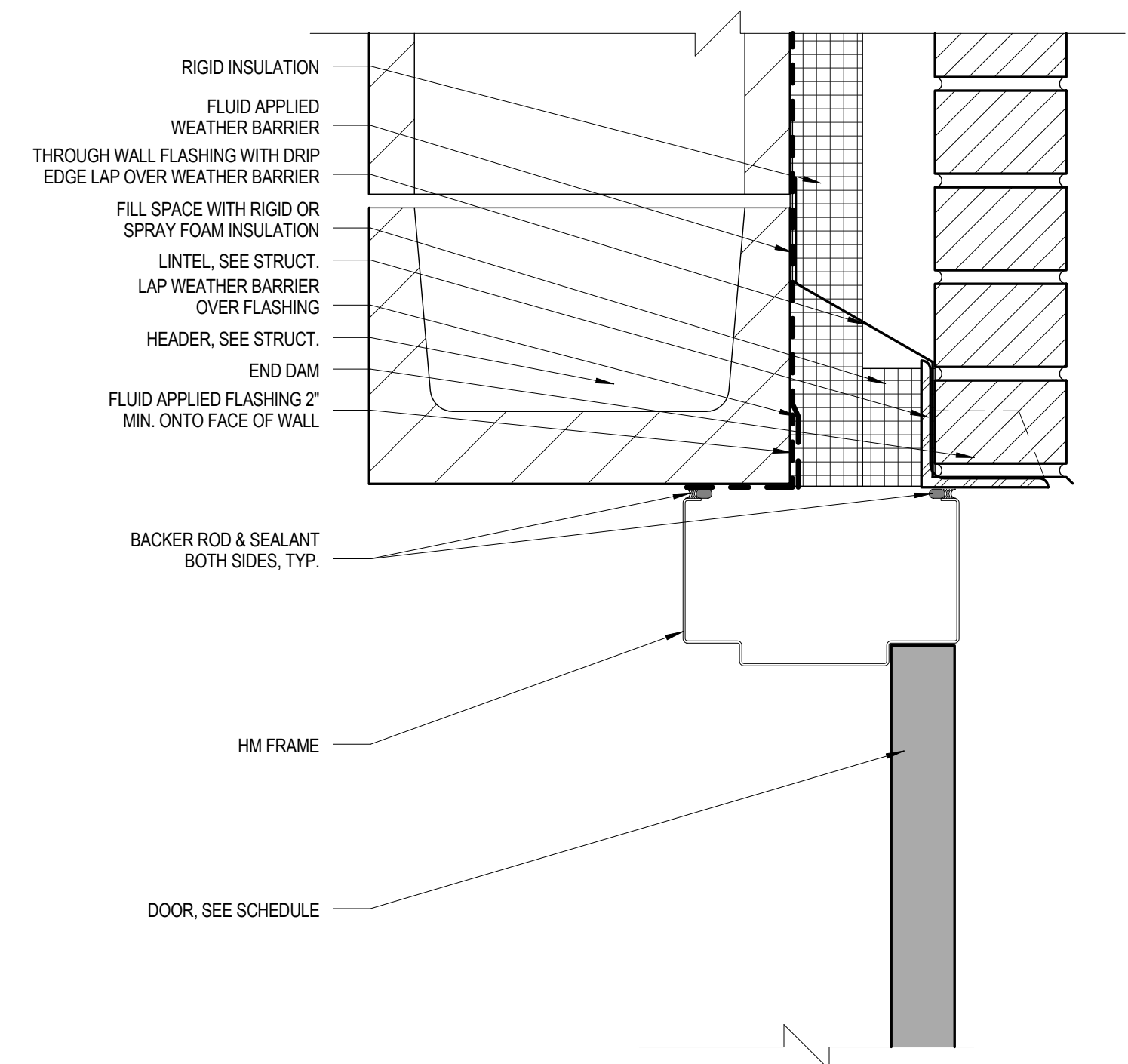

**HM DOOR HEAD DETAIL @ EXTERIOR WALL**  
 3" = 1'-0"

**HM DOOR JAMB DETAIL @ EXTERIOR WALL**  
 3" = 1'-0"

**STOREFRONT HEAD DETAIL**  
 3" = 1'-0"

**STOREFRONT JAMB DETAIL**  
 3" = 1'-0"

**4 DOOR DETAILS**  
 3" = 1'-0"

Sub-Consultant



Revision Schedule  
 No. | Date | Description

Project Title: **CHASE COUNTY SCHOOL - GYM ADDITION**

520 EAST 9TH STREET  
 IMPERIAL, NEBRASKA 68033  
 CHASE COUNTY SCHOOLS

Sheet Title: **DOOR AND WINDOW SCHEDULES**

Completion: 100% CONSTRUCTION DOCUMENTS  
 Date Issued: MAY 16, 2016

Project: 203-003-15

Design Drawing Check  
 Designer Author Checker

Sheet No.

**A-7.00**

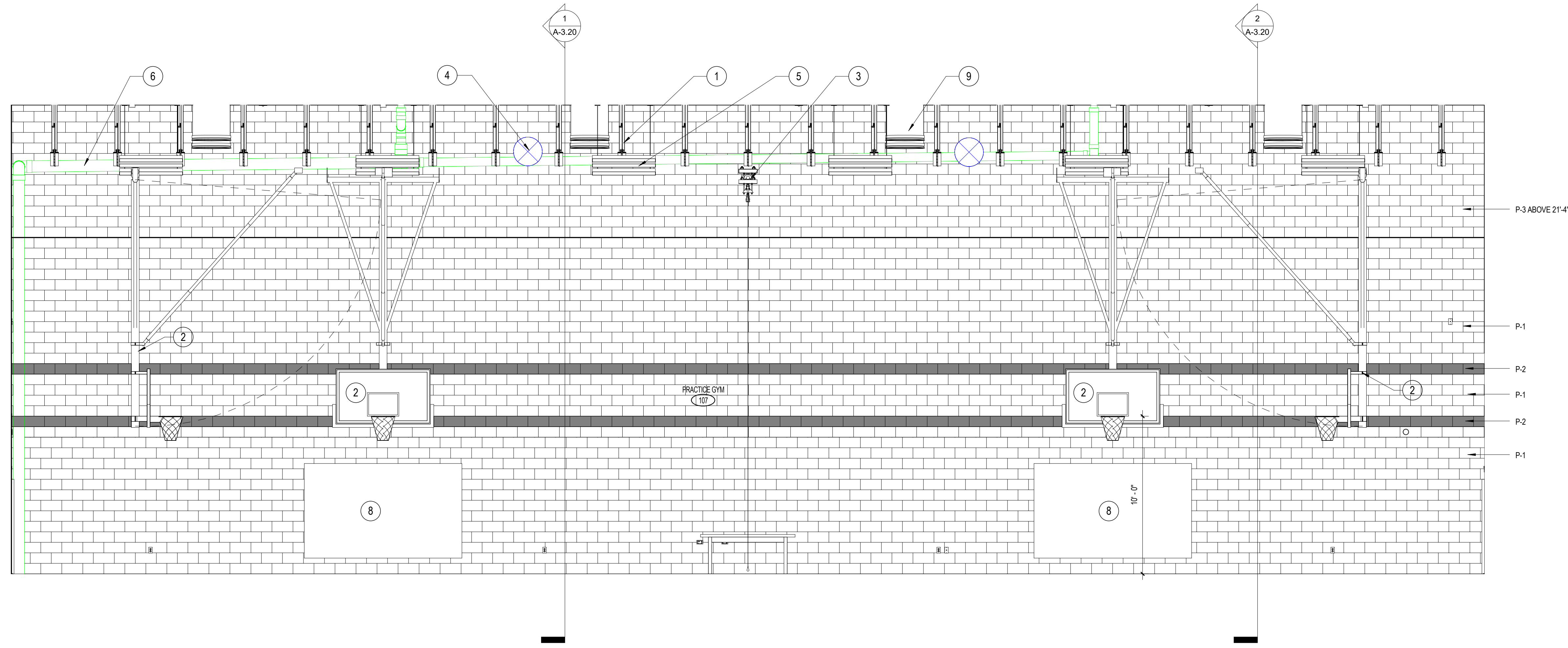

**KEYNOTE LEGEND**

- 1 SEE STRUCTURAL FOR DETAILS
- 2 FORWARD FOLDING BASKETBALL BACKSTOP WITH FRONT SUPPORT.
- 3 GYM DIVIDER CURTAIN.
- 4 HVAC DUCT, SEE MECHANICAL DRAWINGS TYP.
- 5 LIGHT FIXTURE, SEE ELECTRICAL DRAWINGS TYP.
- 6 PLUMBING PIPING, SEE PLUMBING DRAWINGS TYP.
- 7 GYM WALL PADDING, BY OWNER.
- 8 6" H - 2" THICK WALL PADDING AROUND PERIMETER OF WRESTLING MATS.
- 9 SOLATUBE SKYVAULT SERIES, SEE ROOF PLAN.



Revision Schedule	
No.	Date

**1** 1/4" = 1'-0" INT ELEV - ROOM 107 PRACTICE GYM EAST

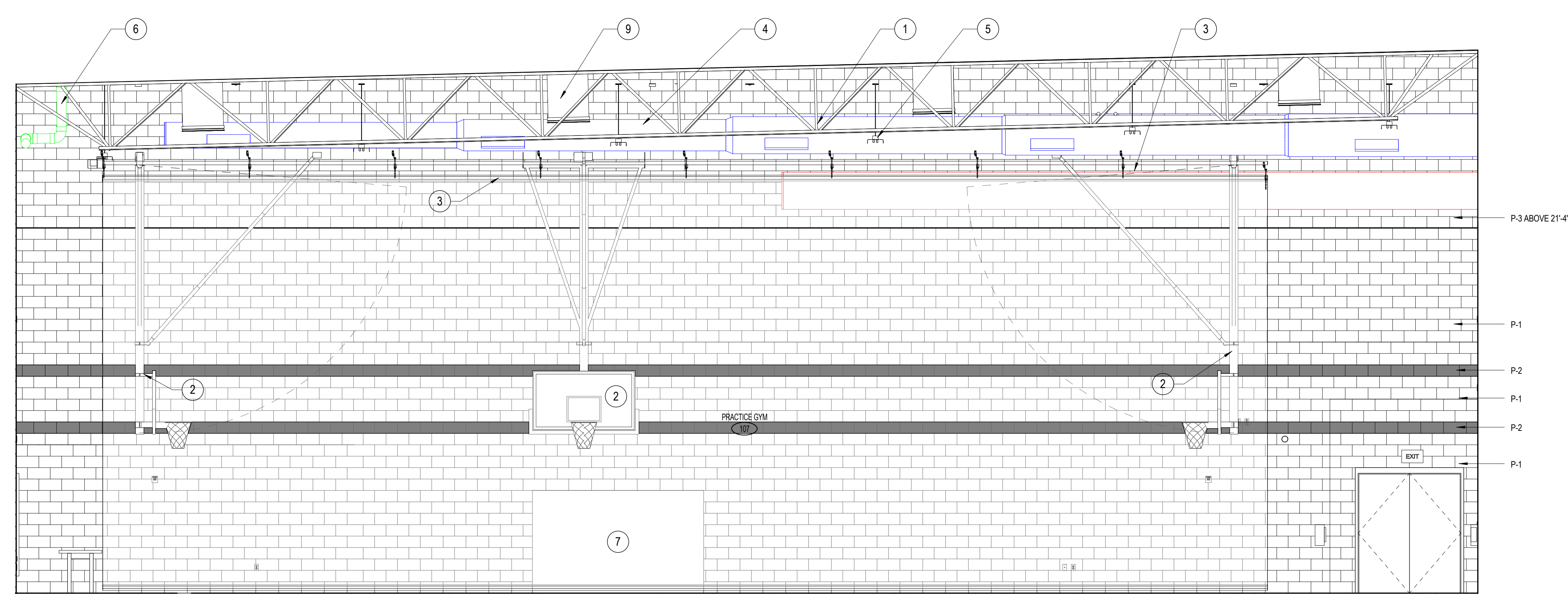

**2** 1/4" = 1'-0" INT ELEV - ROOM 107 PRACTICE GYM SOUTH

Project Title:  
**CHASE COUNTY SCHOOL - GYM ADDITION**  
 520 EAST 9TH STREET  
 IMPERIAL, NEBRASKA 68033  
 CHASE COUNTY SCHOOLS

Sheet Title:  
**INTERIOR ELEVATIONS**  
 Completion: 100% CONSTRUCTION DOCUMENTS  
 Date Issued: MAY 16, 2016

Project: 203-003-15

Design	Drawing	Check
JDW	JDS	JDW

Sheet No.  
**A-8.00**

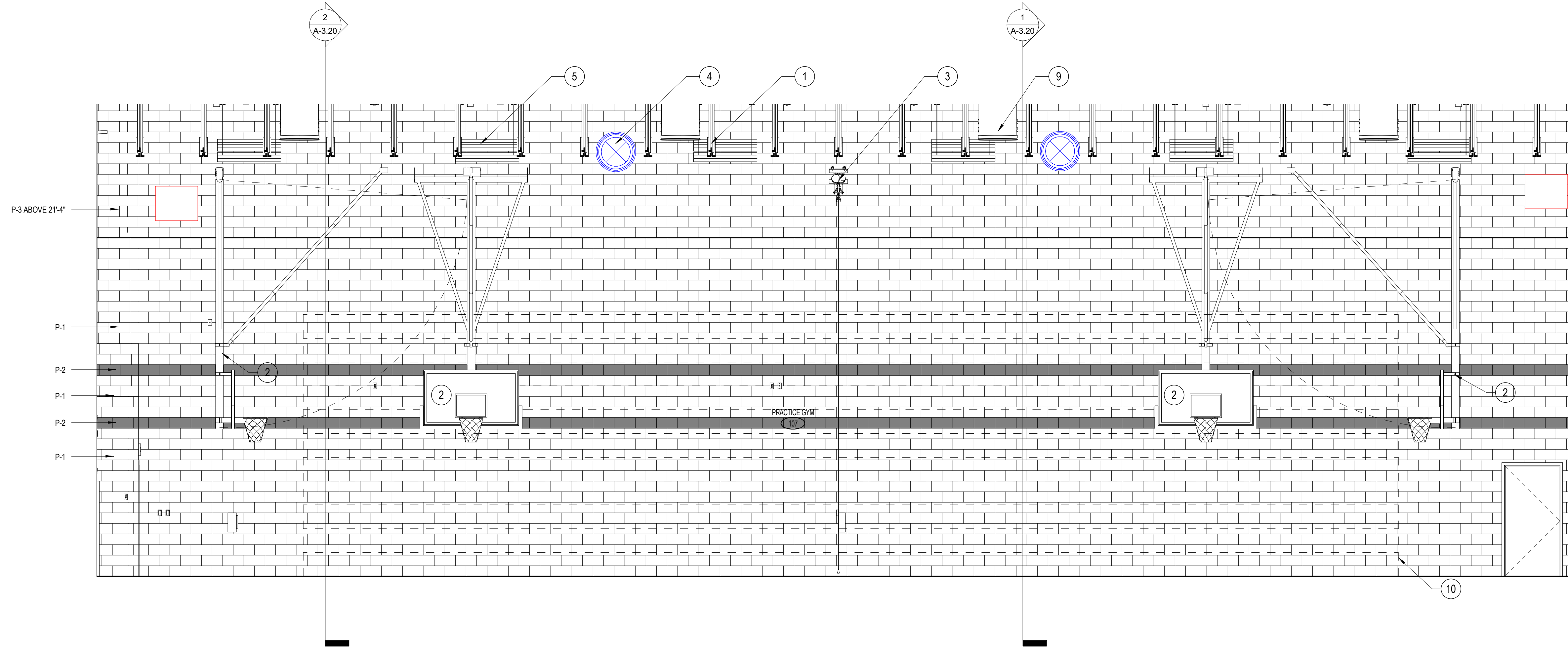

**1** 1/4" = 1'-0" INT ELEV - ROOM 107 PRACTICE GYM WEST

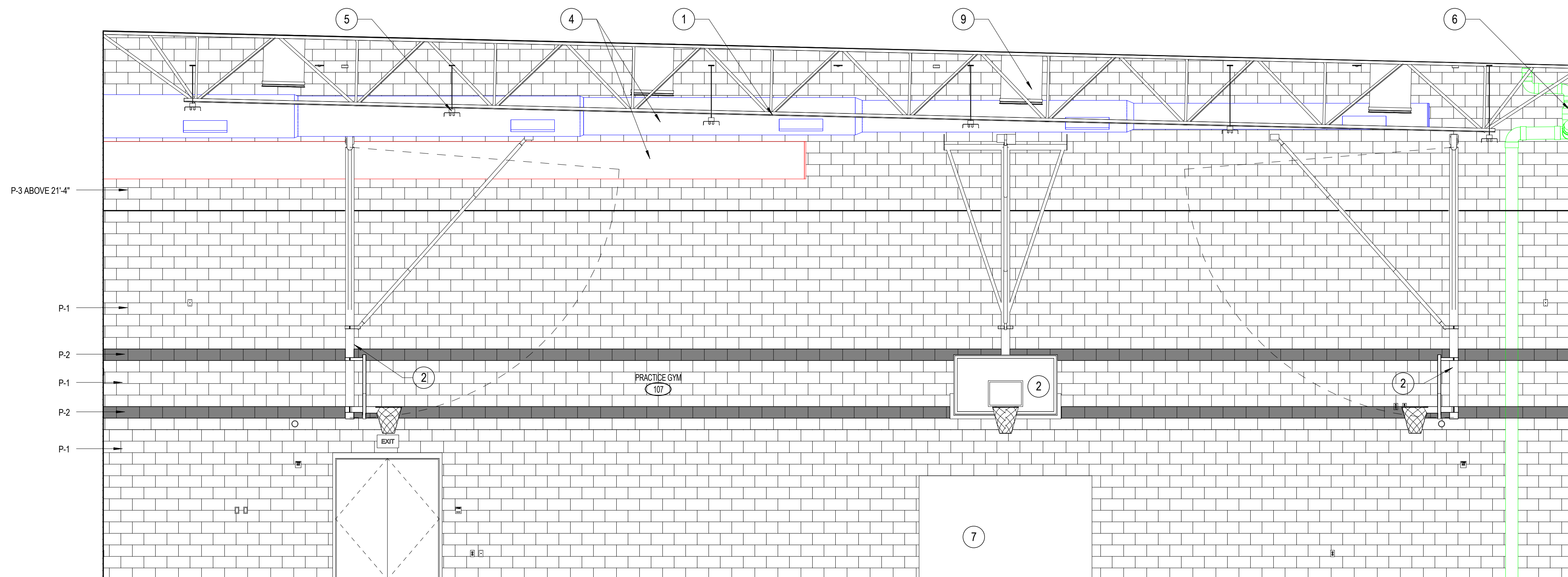

**2** 1/4" = 1'-0" INT ELEV - ROOM 107 PRACTICE GYM NORTH

**KEYNOTE LEGEND**

- 1 SEE STRUCTURAL FOR DETAILS
- 2 FORWARD FOLDING BASKETBALL BACKSTOP WITH FRONT SUPPORT.
- 3 GYM DIVIDER CURTAIN.
- 4 HVAC DUCT, SEE MECHANICAL DRAWINGS TYP.
- 5 LIGHT FIXTURE, SEE ELECTRICAL DRAWINGS TYP.
- 6 PLUMBING PIPING, SEE PLUMBING DRAWINGS TYP.
- 7 GYM WALL PADDING, BY OWNER.
- 8 6" H - 2" THICK WALL PADDING AROUND PERIMETER OF WRESTLING MATS.
- 9 SOLATUBE SKYVAULT SERIES, SEE ROOF PLAN.
- 10 11 ROW FOLDING BLEACHER SYSTEM, 435 SEATS TOTAL.



Revision Schedule	Description
No.	Date

Project Title:  
**CHASE COUNTY SCHOOL - GYM ADDITION**  
 520 EAST 9TH STREET  
 IMPERIAL, NEBRASKA 68033  
 CHASE COUNTY SCHOOLS

Sheet Title:  
**INTERIOR ELEVATIONS**  
 Completion: 100% CONSTRUCTION DOCUMENTS  
 Date Issued: MAY 16, 2016

Project: 203-003-15

Design Drawing Check  
 JDW JDS JDW

Sheet No.  
**A-8.01**



Revision No.	Schedule	Date	Description

Project Title: CHASE COUNTY SCHOOL - GYM ADDITION  
 520 EAST 9TH STREET  
 IMPERIAL, NEBRASKA 68033  
 CHASE COUNTY SCHOOLS

Sheet Title: INTERIOR ELEVATIONS  
 Completion: 100% CONSTRUCTION DOCUMENTS  
 Date Issued: MAY 16, 2016

Project: 203-003-15

Design: JDW Drawing: JDS Check: JDW

Sheet No. A-8.02

**KEYNOTE LEGEND**

- 1 SEE STRUCTURAL FOR DETAILS
- 2 SOLATUBE SKYVAULT SERIES, SEE ROOF PLAN.
- 3 6" H - 2" THICK WALL PADDING AROUND PERIMETER OF WRESTLING MATS.
- 4 HVAC DUCT/EQUIPMENT, SEE MECHANICAL DRAWINGS TYP.
- 5 LIGHT FIXTURE, SEE ELECTRICAL DRAWINGS TYP.
- 6 PLUMBING PIPING, SEE PLUMBING DRAWINGS TYP.
- 7 1" ACOUSTIC WALL PANELS, TECTUM KERFER WALL PANELS OR APPROVED EQUAL. MOUNT TO 6" STUDS OVER EXISTING EIFS. ANCHOR TO NEW CMU WALLS.
- 8 PAINT EXISTING BRICK.

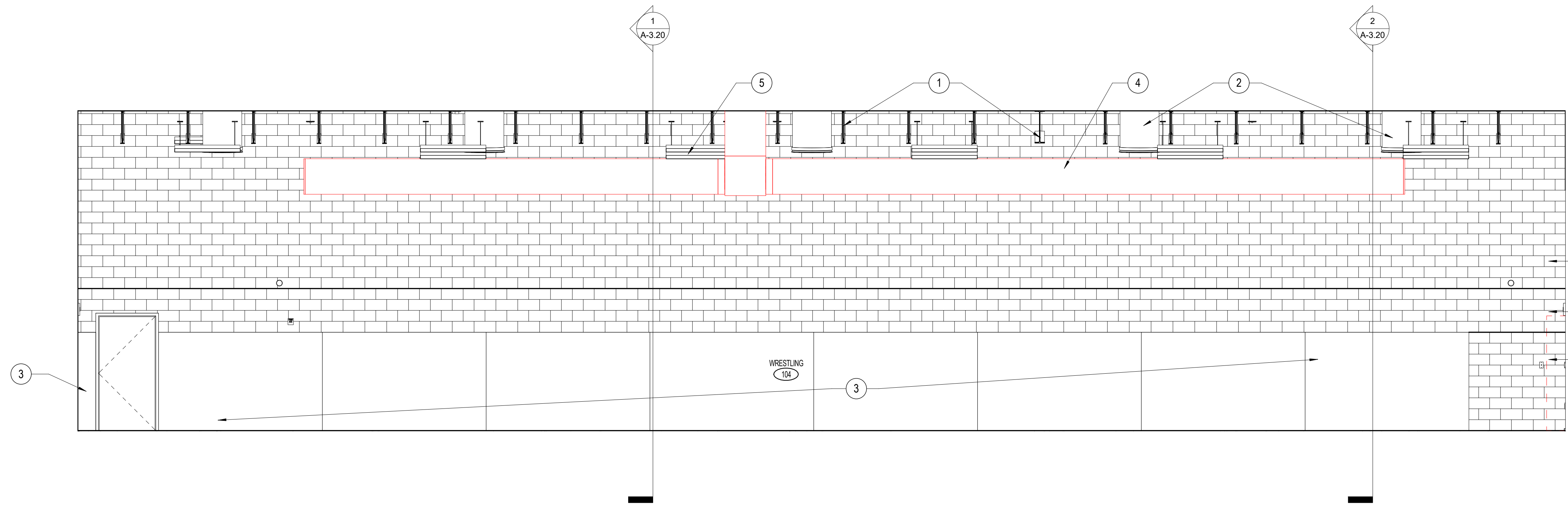

**1** 1/4" = 1'-0" INT ELEV - ROOM 104 WRESTLING EAST

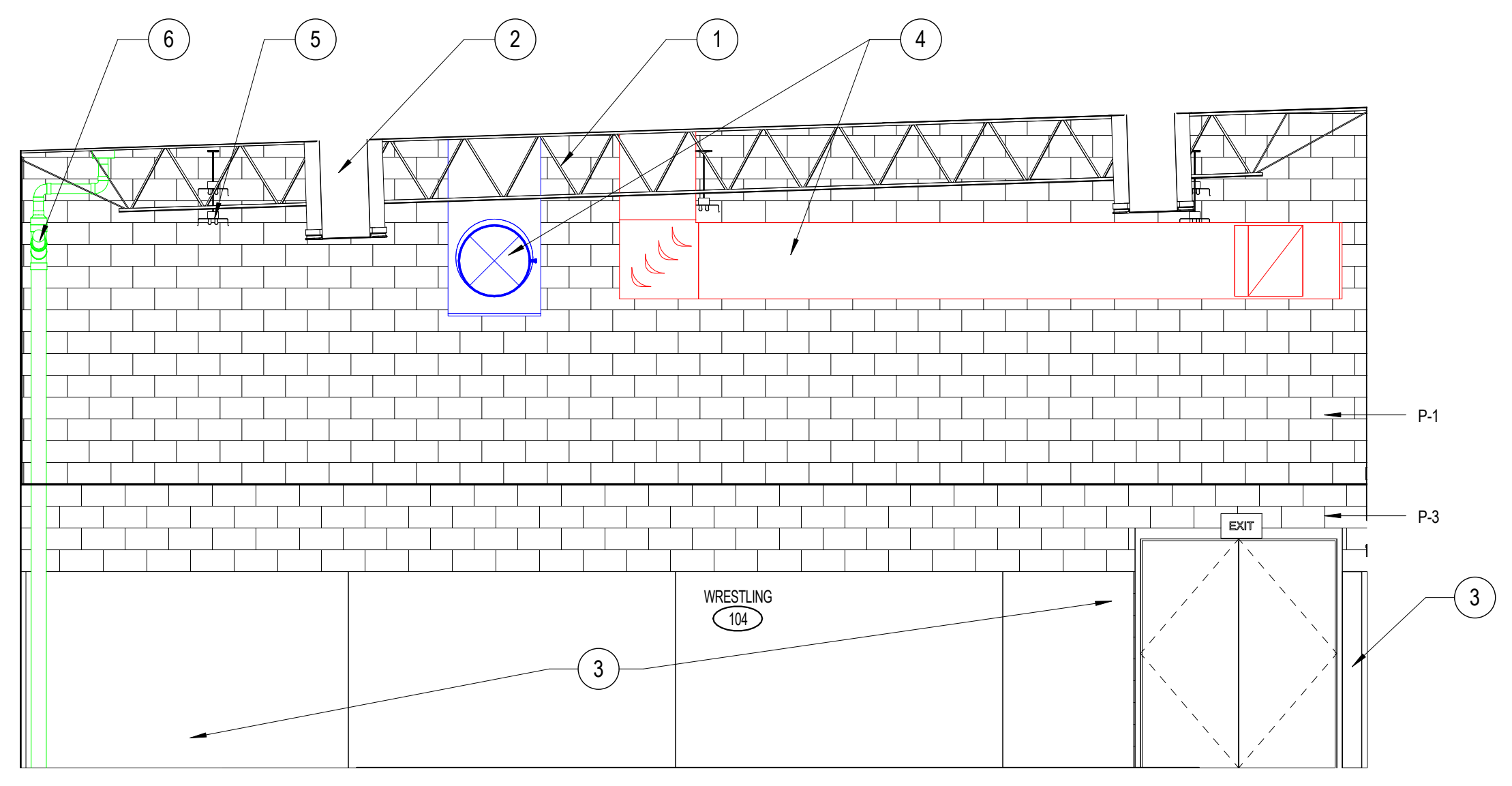

**3** 1/4" = 1'-0" INT ELEV - ROOM 104 WRESTLING NORTH

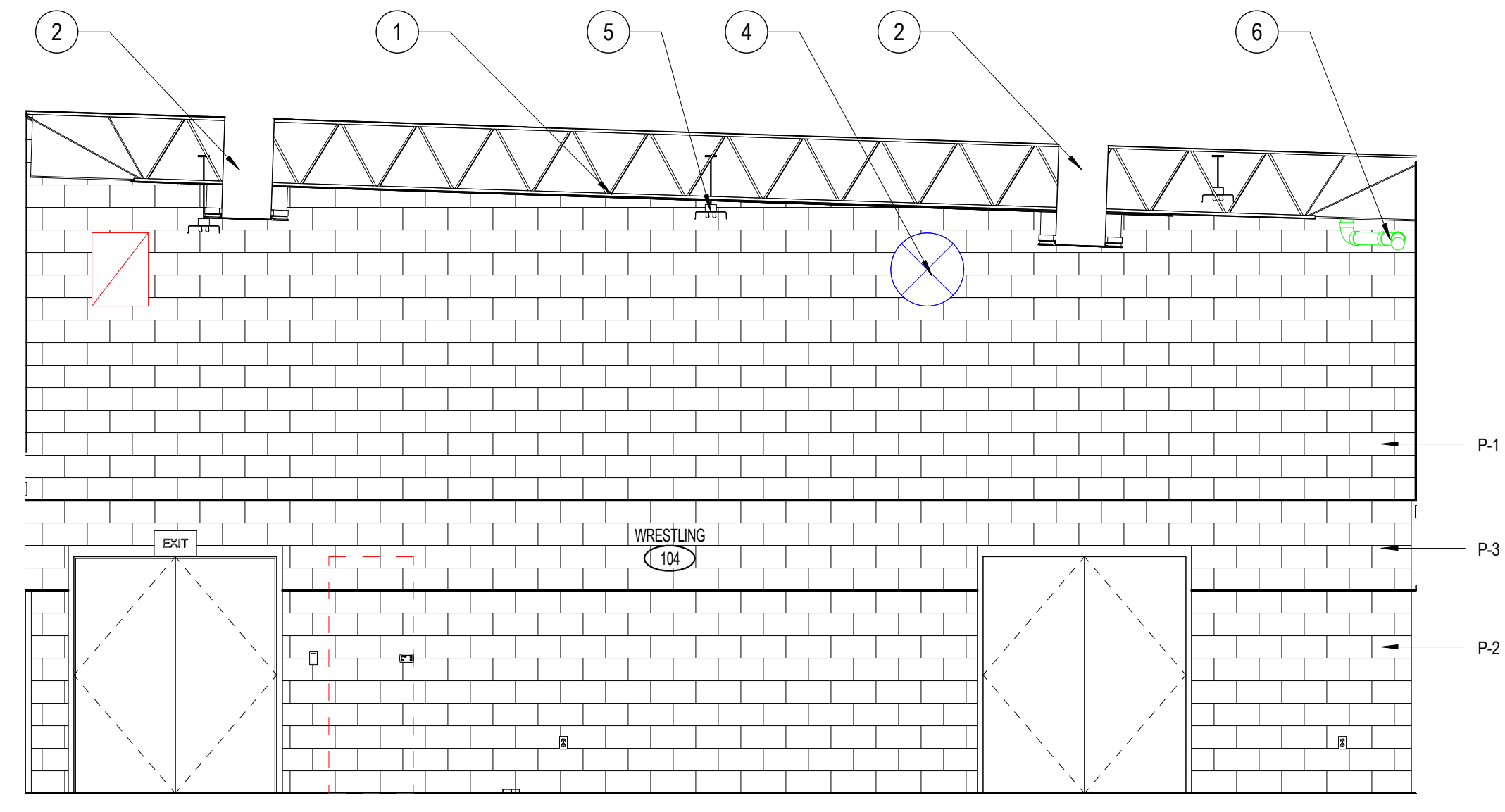

**2** 1/4" = 1'-0" INT ELEV - ROOM 104 WRESTLING SOUTH

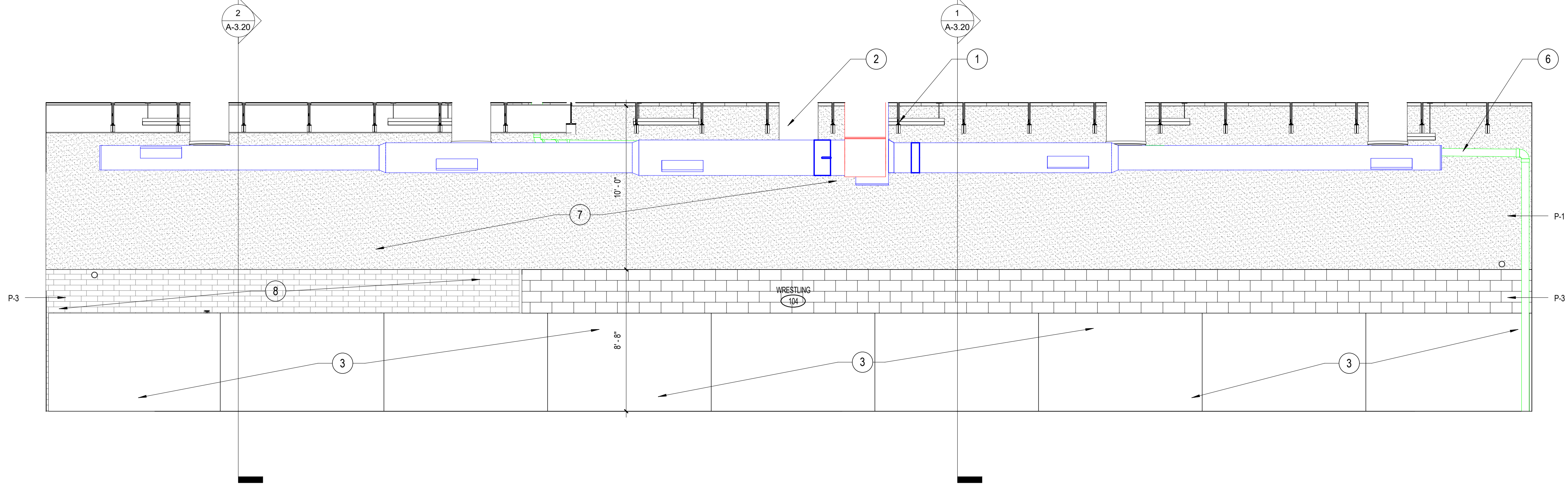

**4** 1/4" = 1'-0" INT ELEV - ROOM 104 WRESTLING WEST

**KEYNOTE LEGEND**

- 1 SEE STRUCTURAL FOR DETAILS
- 2 HVAC DUCT/EQUIPMENT, SEE MECHANICAL DRAWINGS TYP.
- 3 LIGHT FIXTURE, SEE ELECTRICAL DRAWINGS TYP.
- 4 PLUMBING PIPING, SEE PLUMBING DRAWINGS TYP.
- 5 ATHLETIC LOCKERS, SET ON ONE COURSE OF 8" CMU CURB.
- 6 LOCKER ROOM BENCHES.
- 7 TILE PATTERN B, SEE TILE PATTEN ELEVATIONS ON SHEET A-10.00.
- 8 TILE PATTERN A, SEE TILE PATTEN ELEVATIONS ON SHEET A-10.00.
- 9 ERF-1 COVE BASE WITH METAL TRIM CAP.
- 10 SCHLUTER STRIP SCH-1 USED ON ALL TILE OUTER CORNERS, SEE FINISH SCHEDULE
- 11 TILE PATTERN C, SEE TILE PATTEN ELEVATIONS ON SHEET A-10.00.

**9** 1/4" = 1'-0" INT ELEV - ROOM 127 MENS LOCKERS WEST

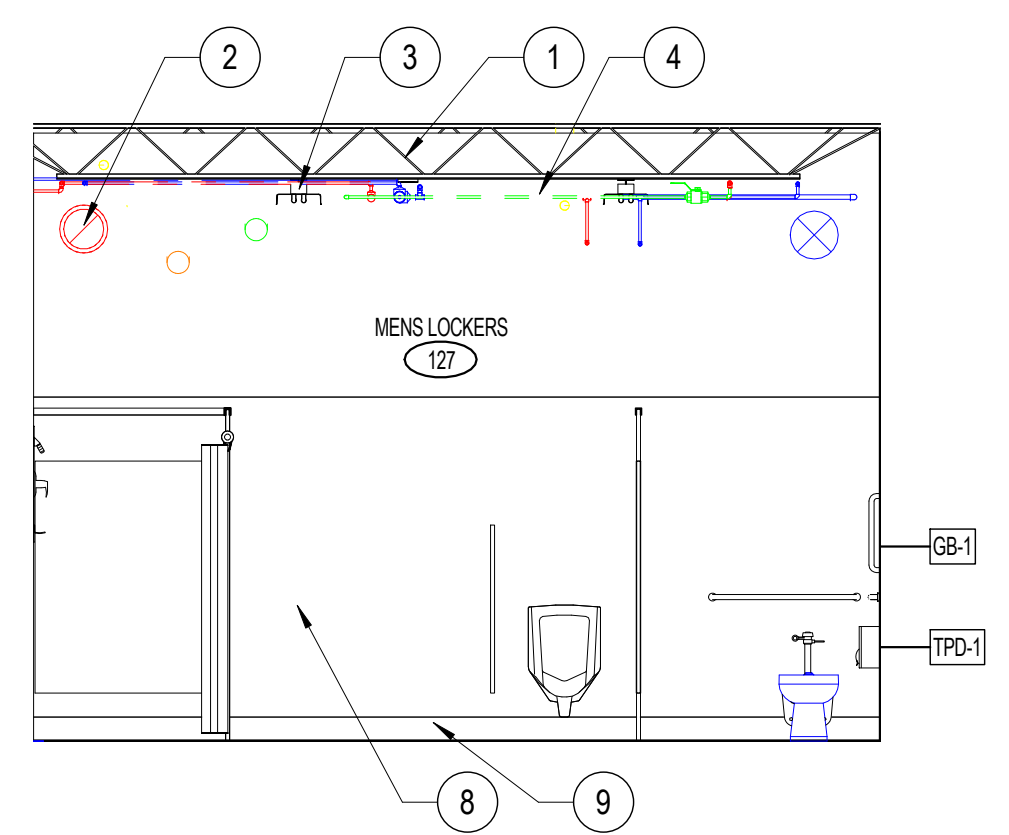

**5** 1/4" = 1'-0" INT ELEV - ROOM 126 WOMENS LOCKERS SOUTH 2

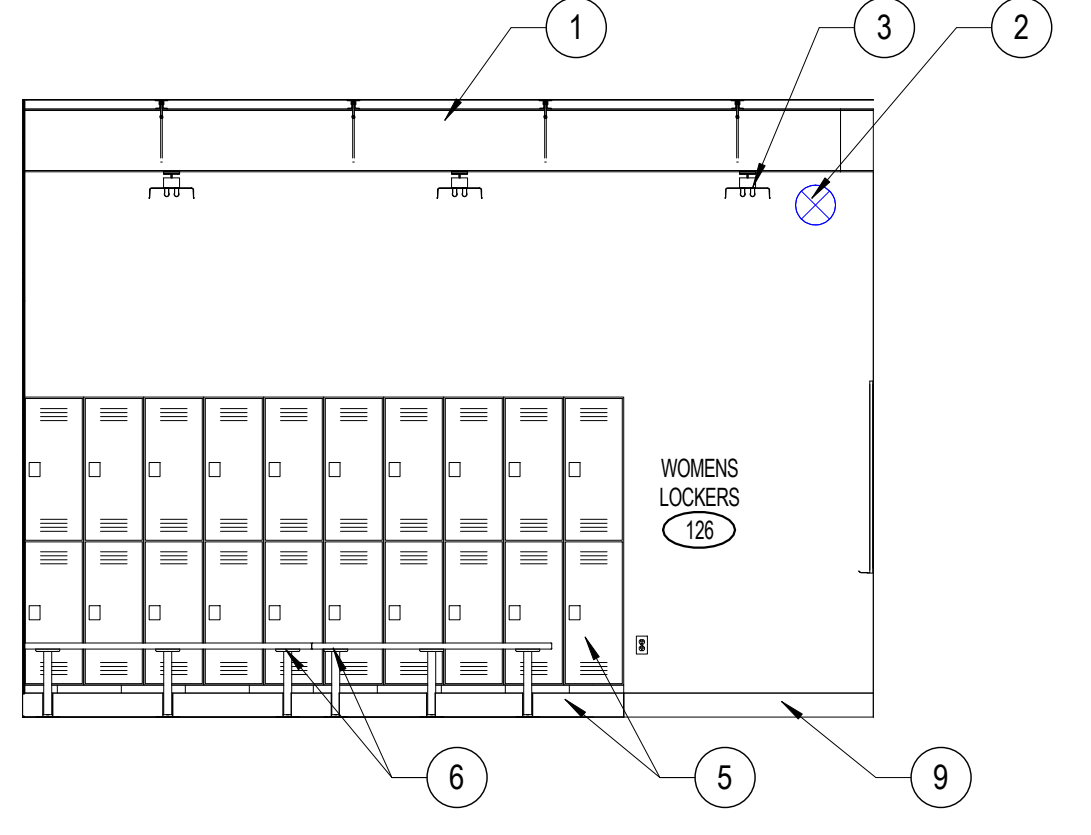

**1** 1/4" = 1'-0" INT ELEV - ROOM 126 WOMENS LOCKERS NORTH

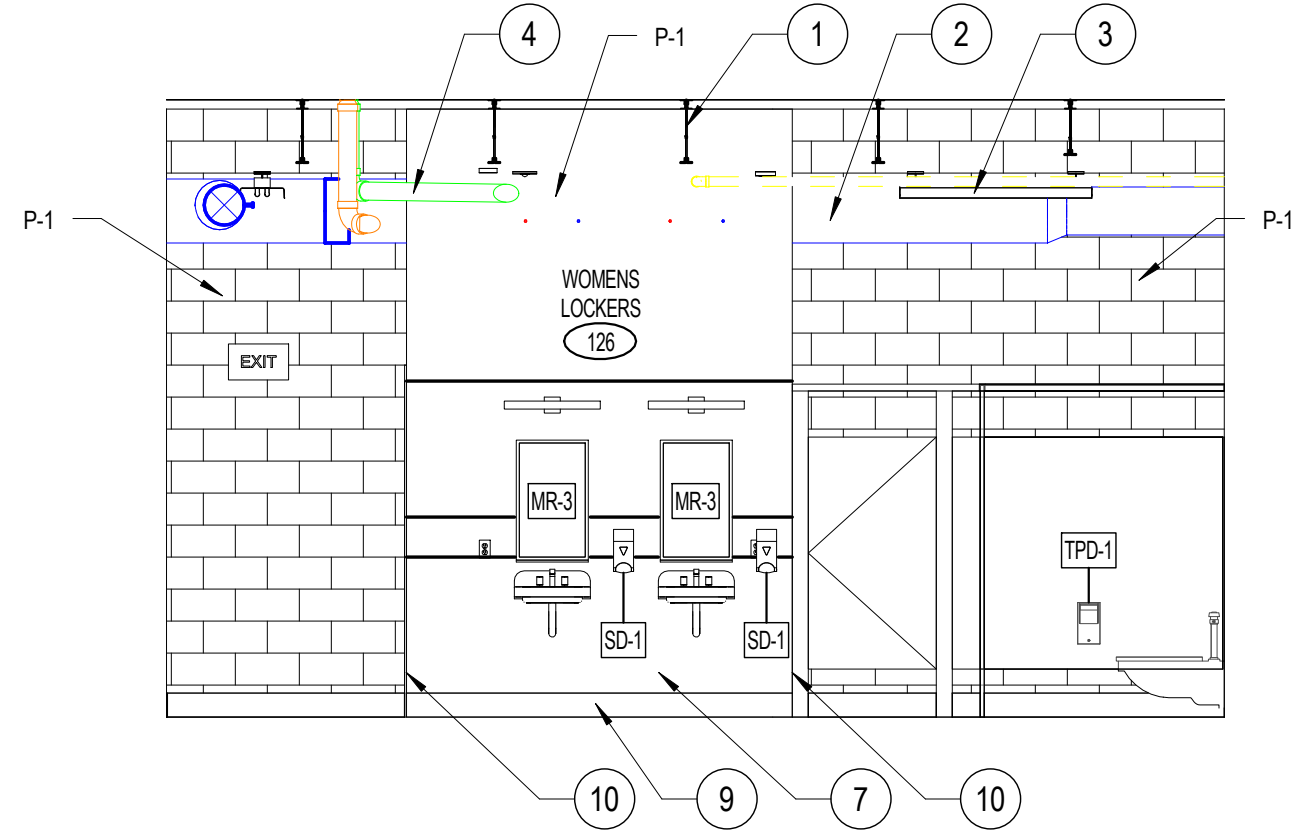

**10** 1/4" = 1'-0" INT ELEV - ROOM 127 MENS LOCKERS WEST 2

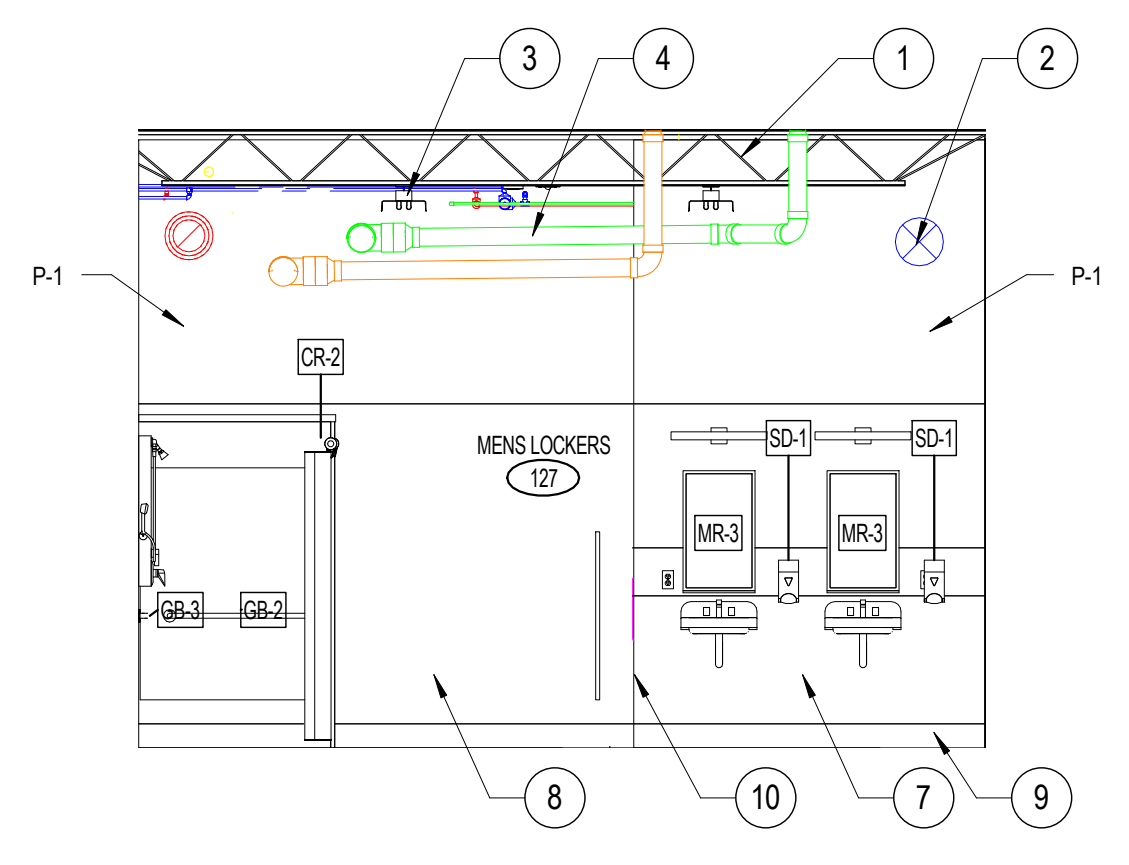

**6** 1/4" = 1'-0" INT ELEV - ROOM 127 MENS LOCKERS NORTH

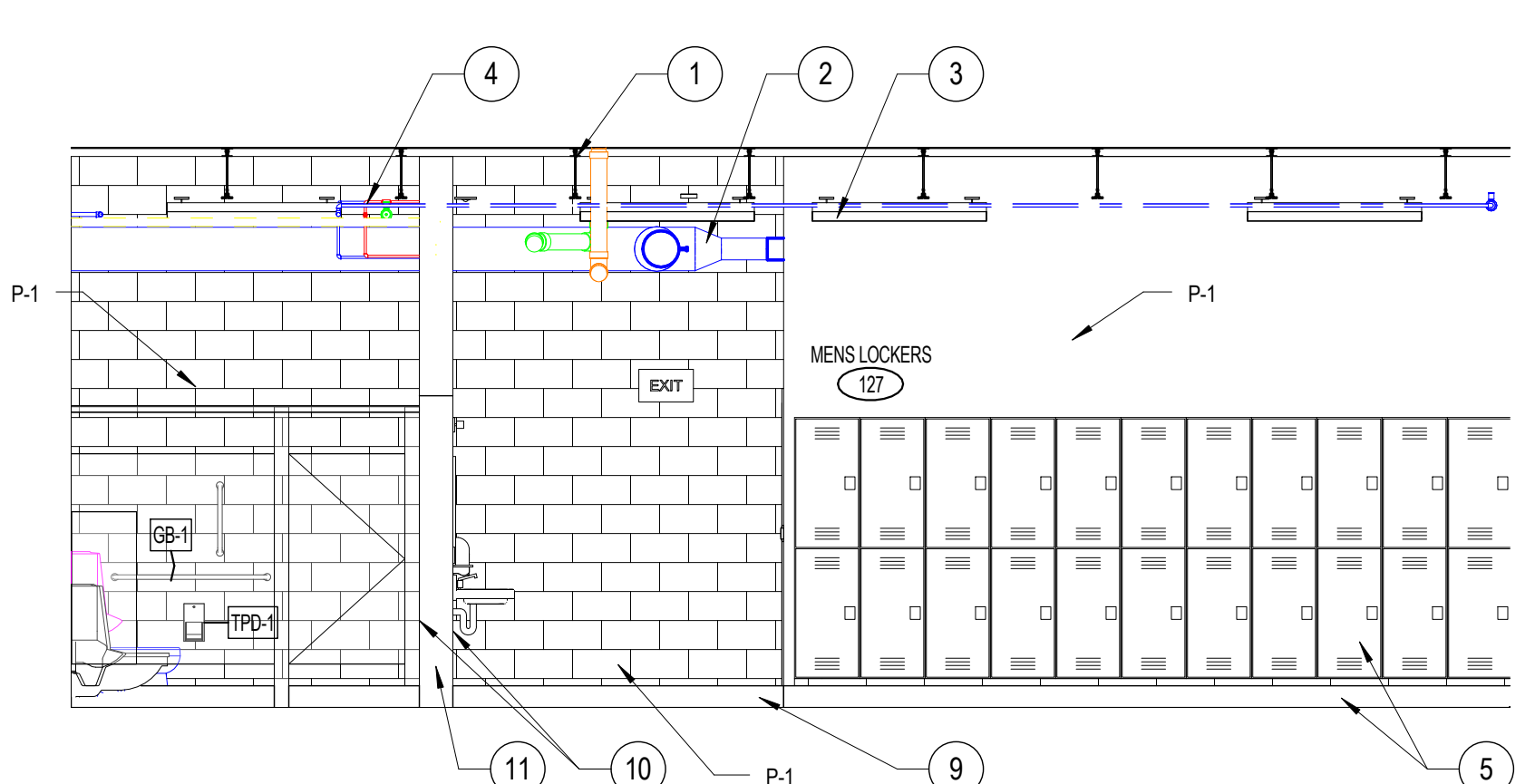

**2** 1/4" = 1'-0" INT ELEV - ROOM 126 WOMENS LOCKERS EAST

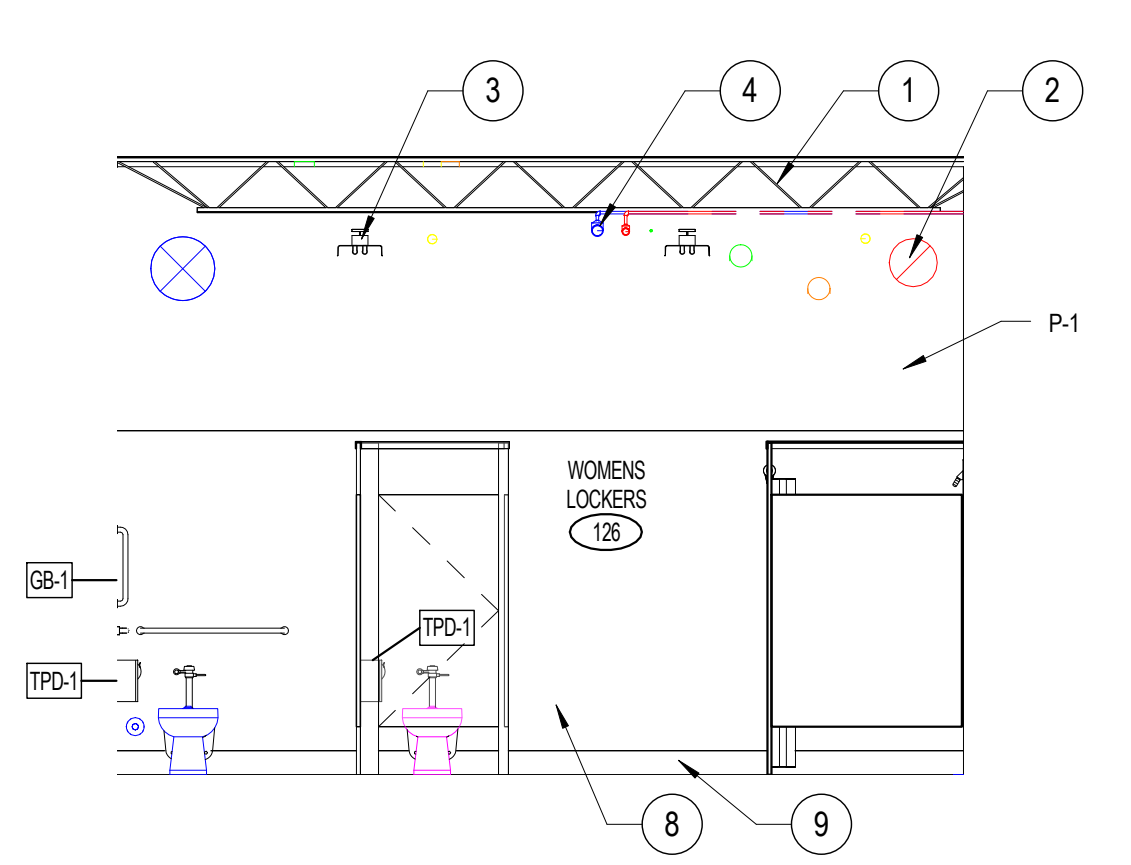

**7** 1/4" = 1'-0" INT ELEV - ROOM 127 MENS LOCKERS EAST

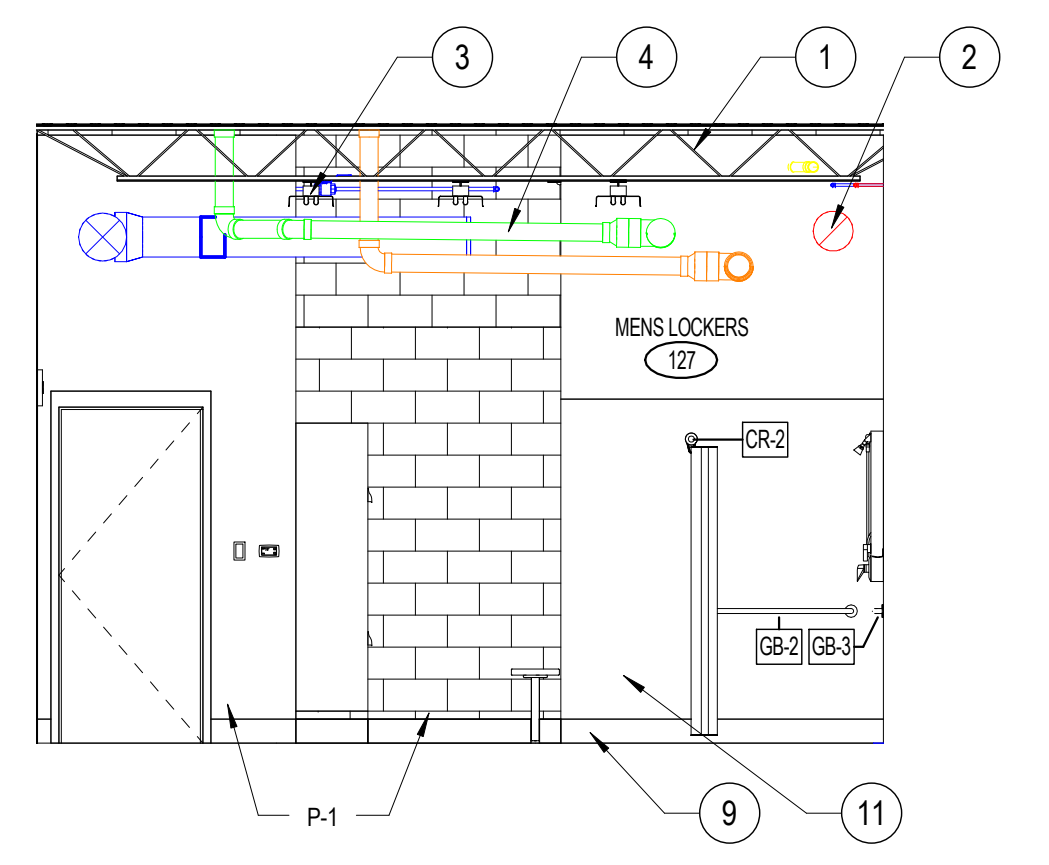

**3** 1/4" = 1'-0" INT ELEV - ROOM 126 WOMENS LOCKERS SOUTH

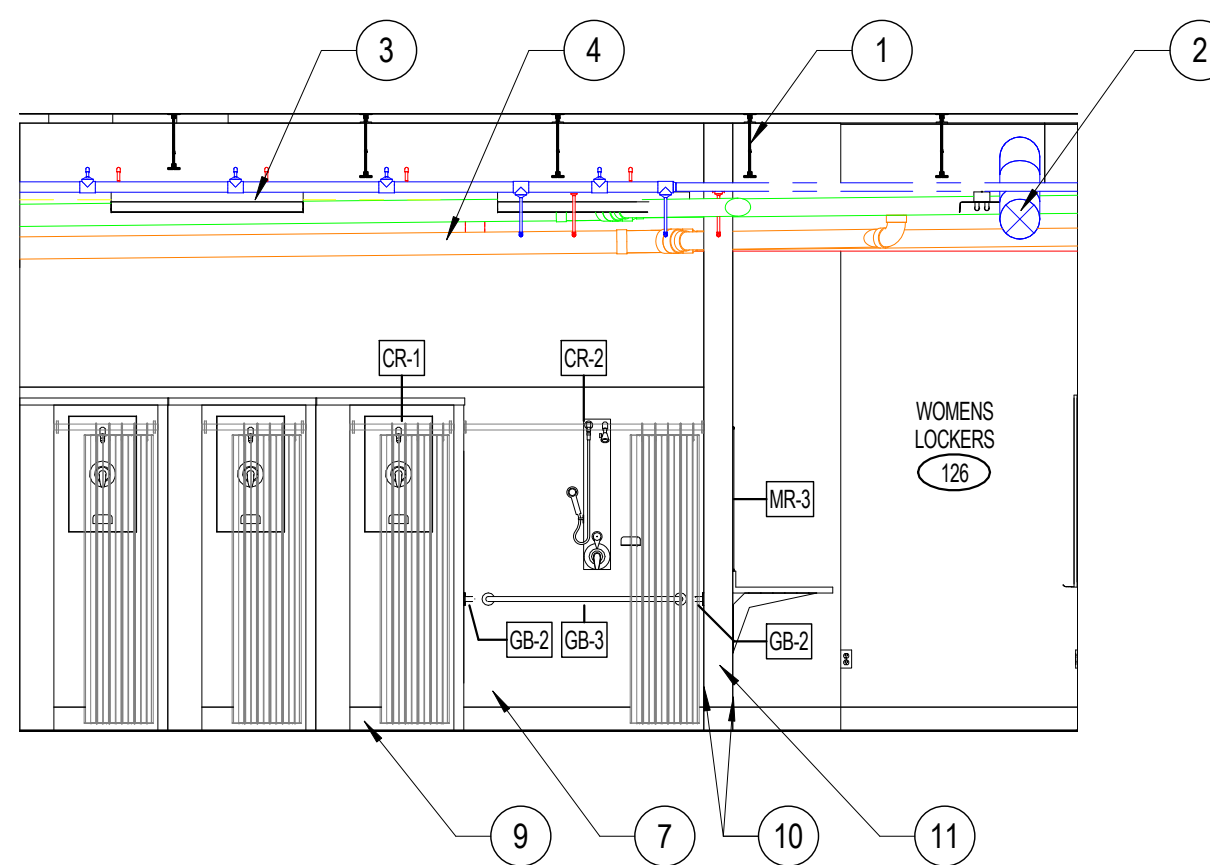

**8** 1/4" = 1'-0" INT ELEV - ROOM 127 MENS LOCKERS SOUTH

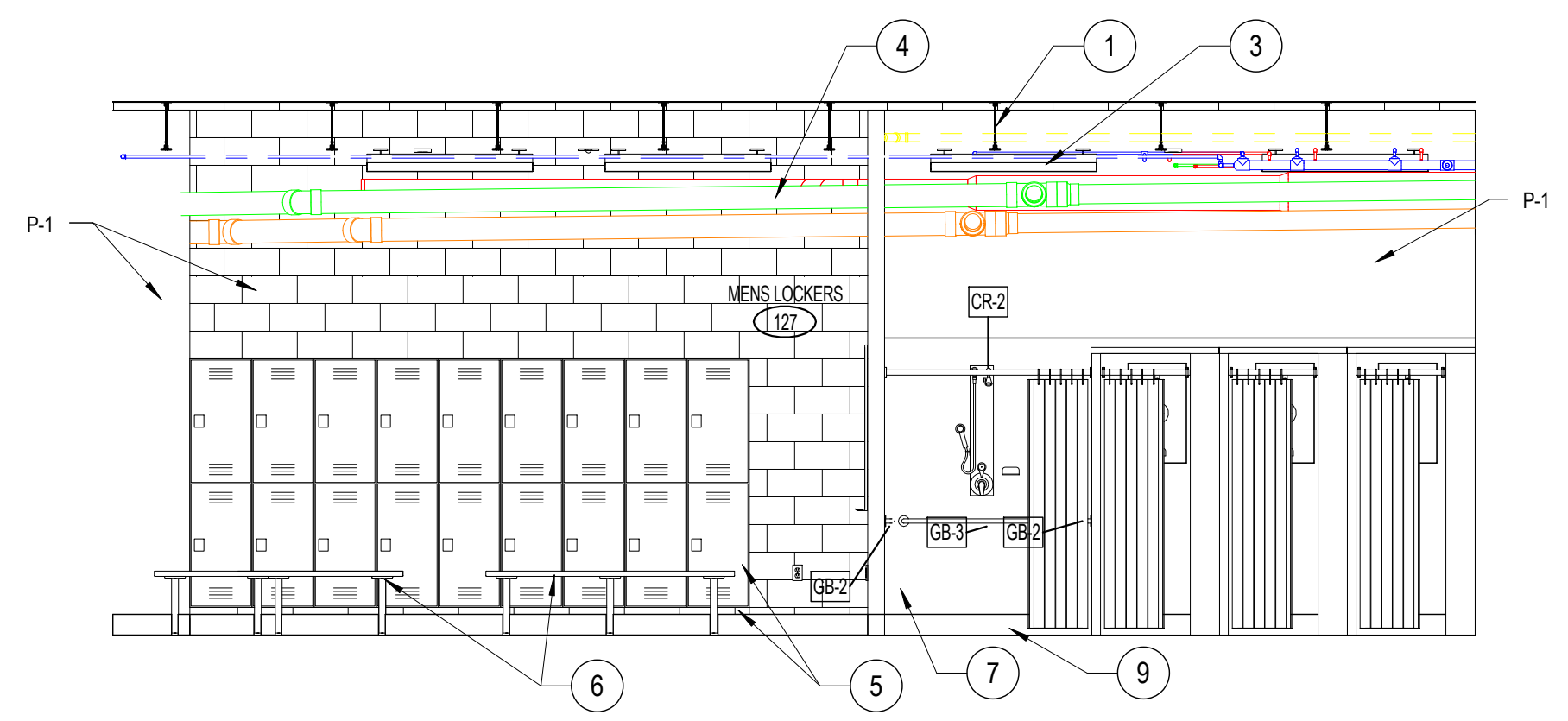

**4** 1/4" = 1'-0" INT ELEV - ROOM 126 WOMENS LOCKERS EAST 2

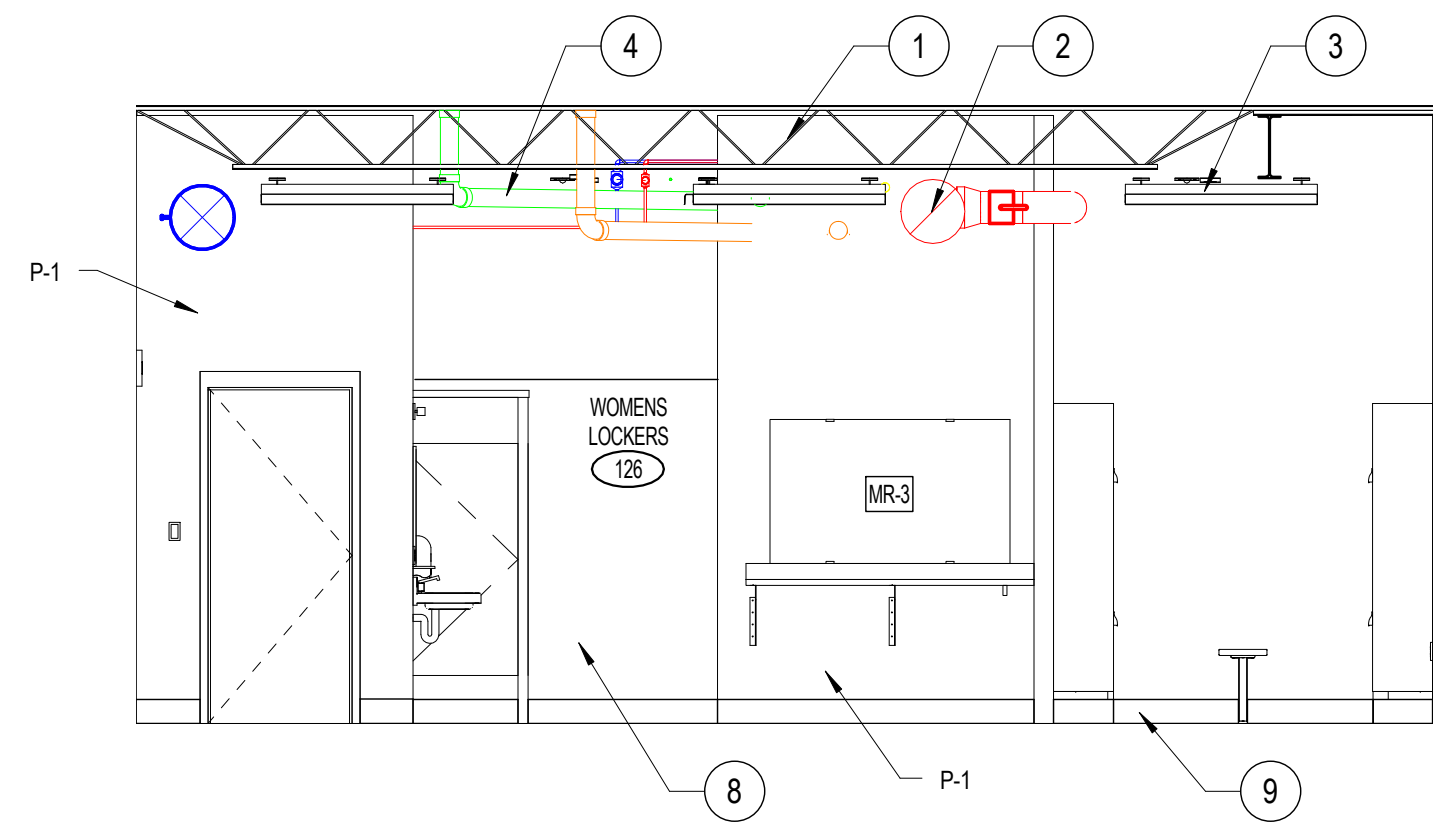

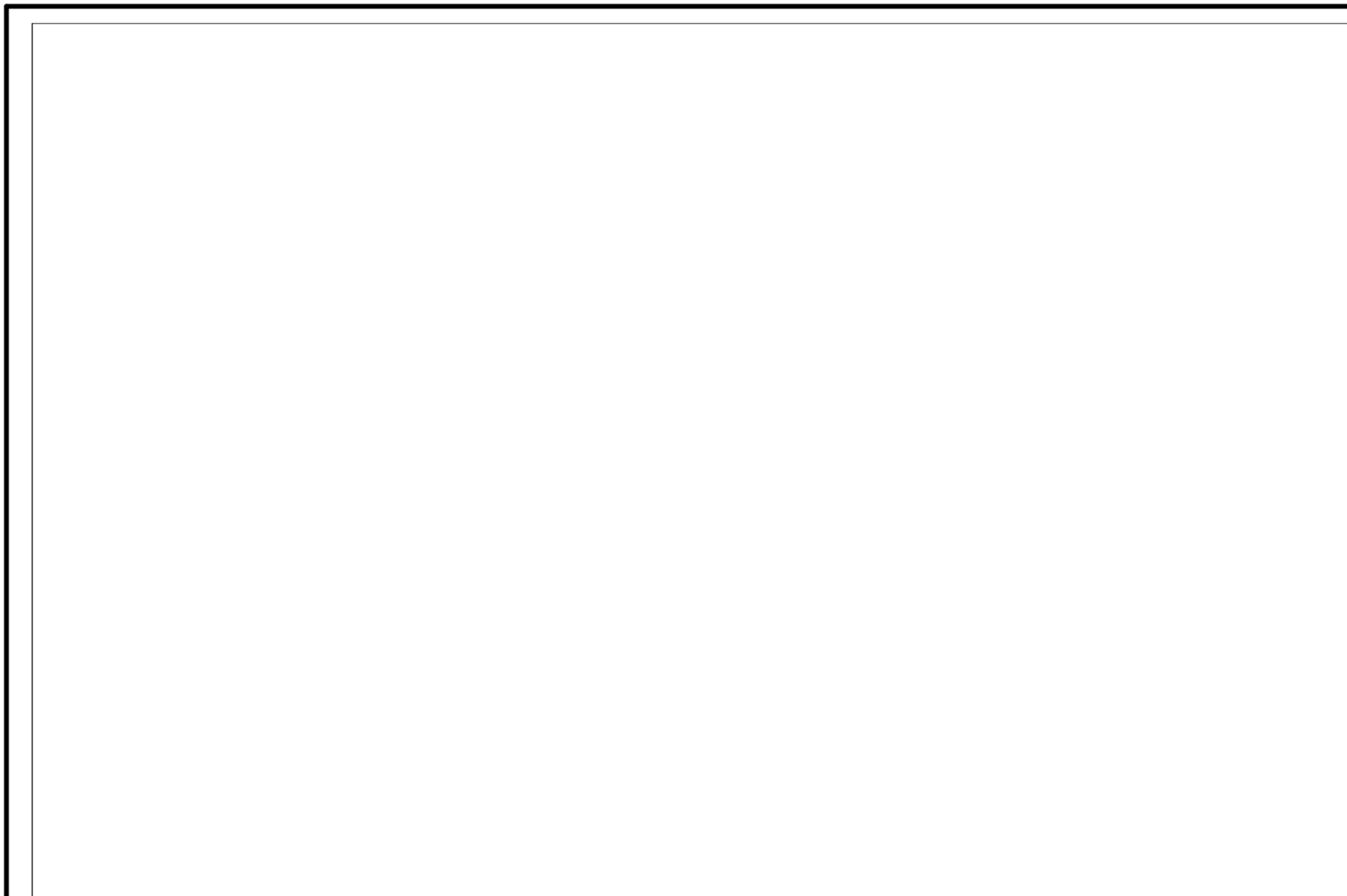

**5** 1/4" = 1'-0" INT ELEV - ROOM 130 WOMENS RESTROOM EAST

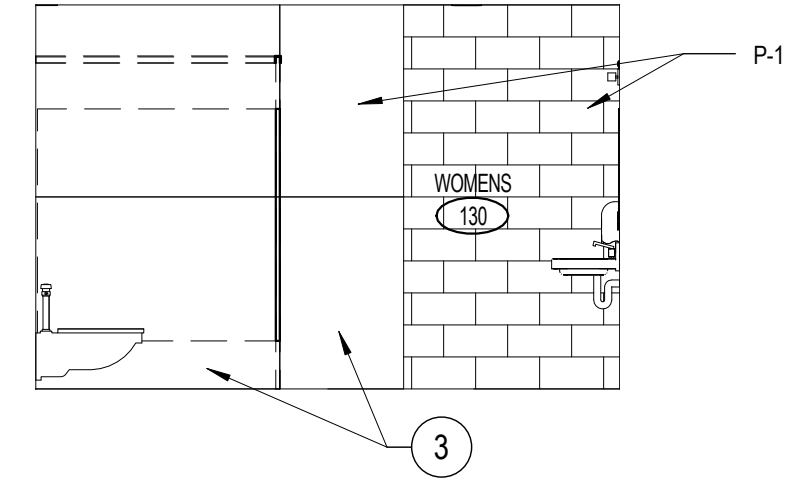

**1** 1/4" = 1'-0" INT ELEV - ROOM 131 MENS RESTROOM NORTH



**6** 1/4" = 1'-0" INT ELEV - ROOM 130 WOMENS RESTROOM SOUTH

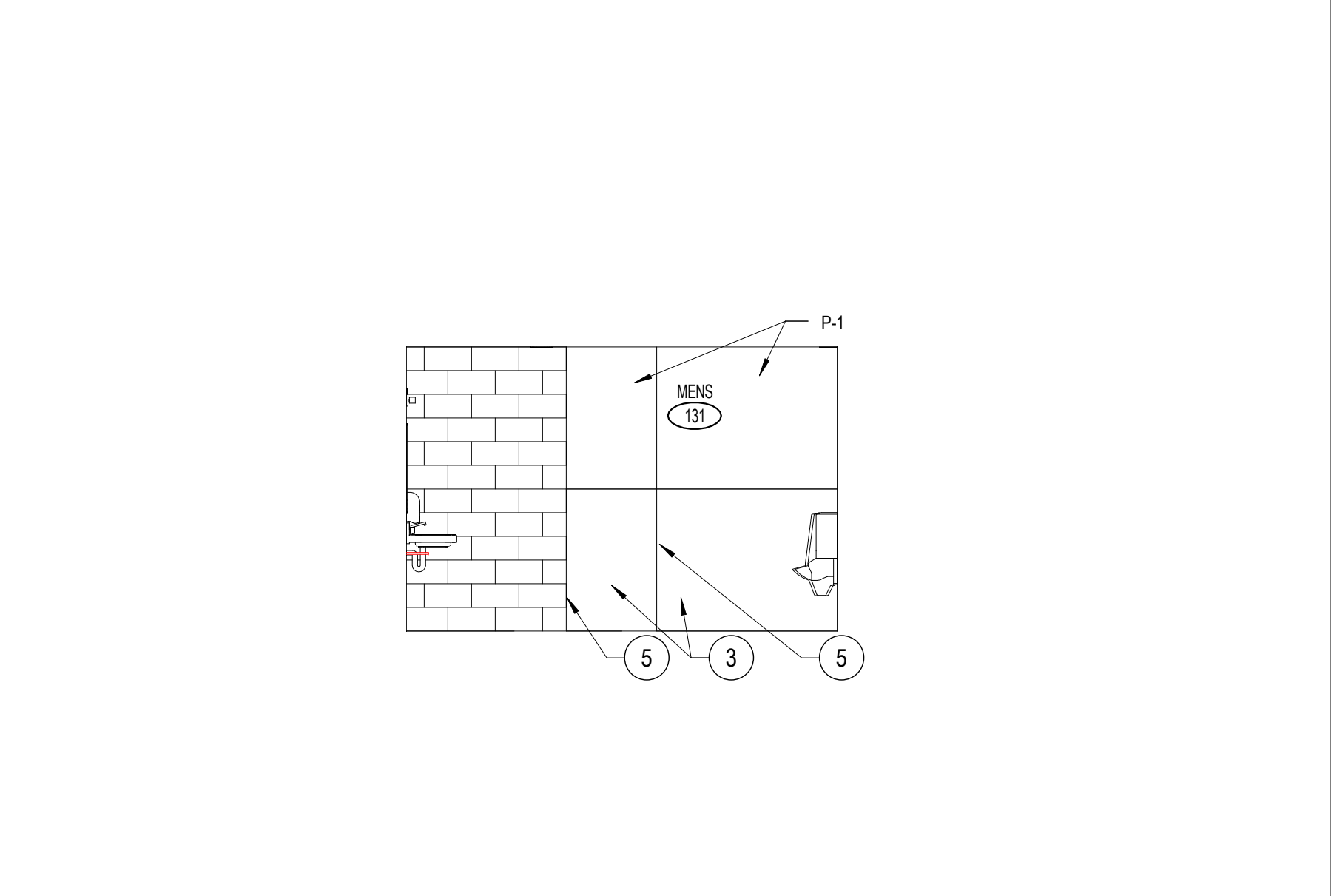

**2** 1/4" = 1'-0" INT ELEV - ROOM 131 MENS RESTROOM EAST

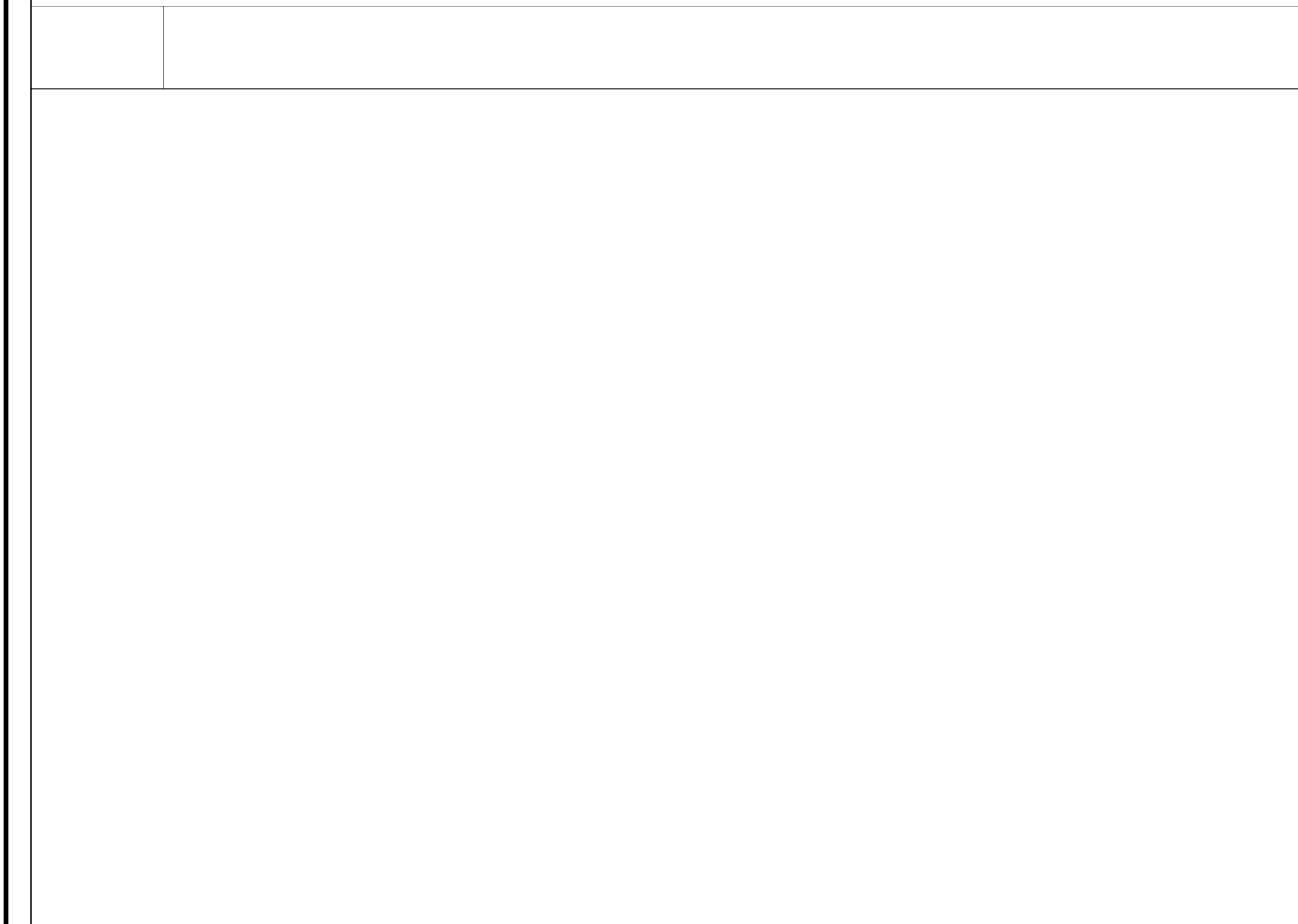

**7** 1/4" = 1'-0" INT ELEV - ROOMS 130 & 131 RESTROOMS ENTRANCE

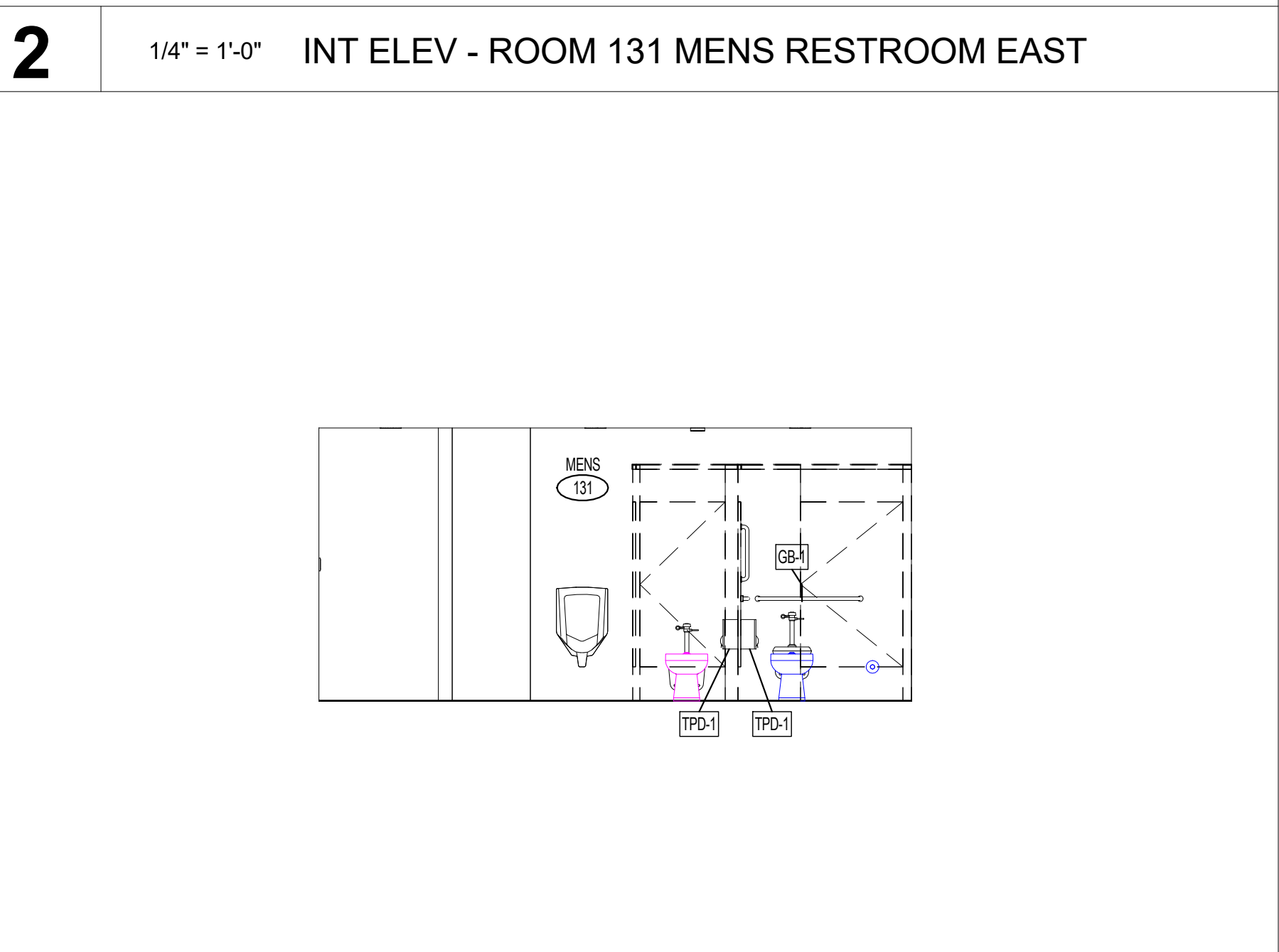

**3** 1/4" = 1'-0" INT ELEV - ROOM 131 MENS RESTROOM SOUTH

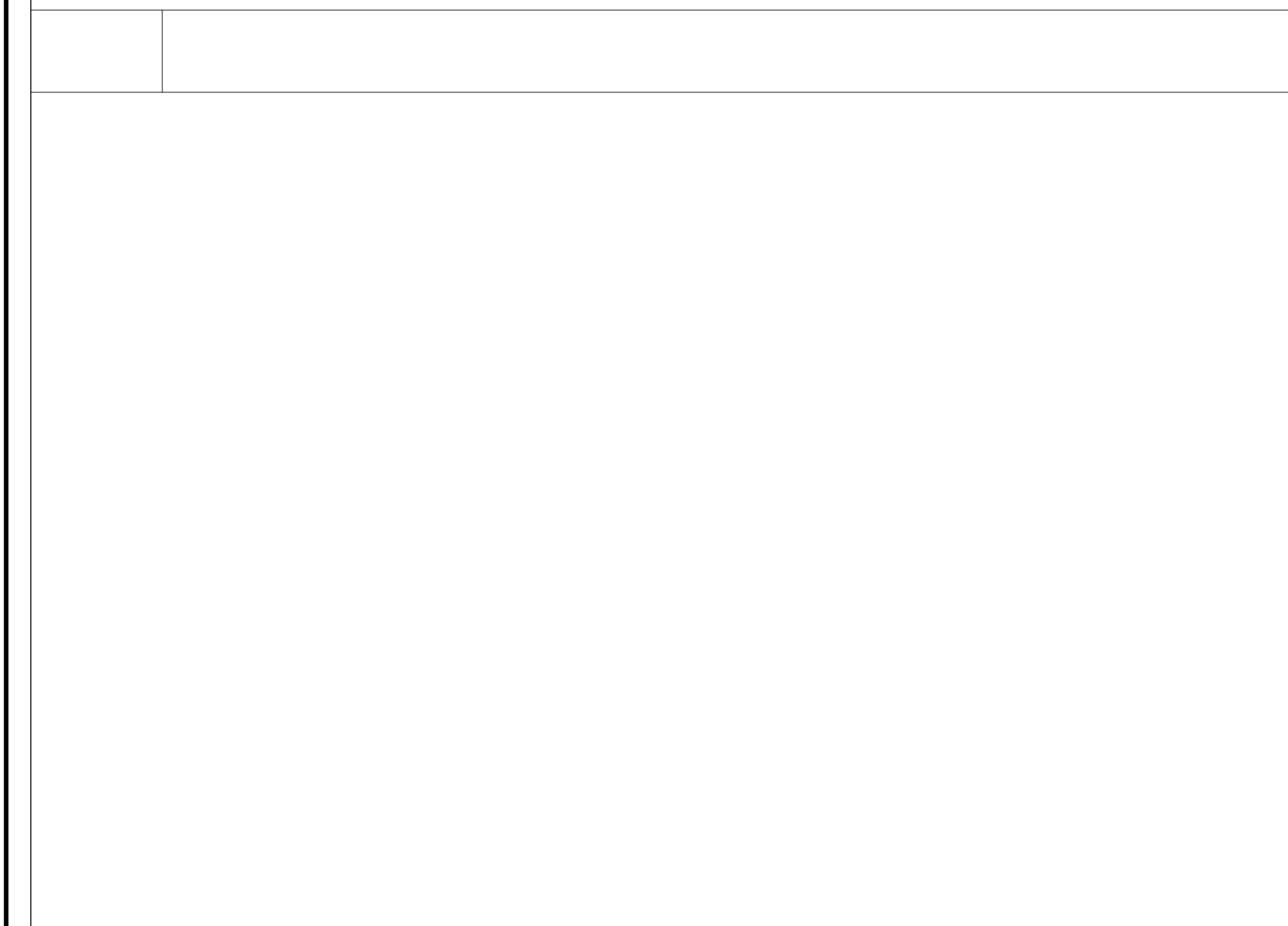

**4** 1/4" = 1'-0" INT ELEV - ROOM 130 WOMENS RESTROOM NORTH

**KEYNOTE LEGEND**

- 1 LIGHT FIXTURE, SEE ELECTRICAL DRAWINGS TYP.
- 2 TILE PATTERN D, SEE TILE PATTEN ELEVATIONS ON SHEET A-10.00
- 3 TILE PATTERN E, SEE TILE PATTEN ELEVATIONS ON SHEET A-10.00
- 4 SCHLUTER STRIP SCH-1 USED ON ALL TILE OUTSIDE CORNERS--SEE FINISH SCHEDULE



Revision Schedule	
No.	Description

Project Title: CHASE COUNTY SCHOOL - GYM ADDITION  
 520 EAST 9TH STREET  
 IMPERIAL, NEBRASKA 68033  
 CHASE COUNTY SCHOOLS

Sheet Title: INTERIOR ELEVATIONS  
 Completion: 100% CONSTRUCTION DOCUMENTS  
 Date Issued: MAY 16, 2016

Project: 203-003-15

Design: JDW Drawing: JDS Check: JDW

Sheet No.

**A-8.04**

### Room Finish Schedule

ROOM NUMBER	ROOM DESCRIPTION	AREA	FLOOR FINISH	BASE FINISH	WALLS				CEILING FINISH	HEIGHT	NOTES
					NORTH	EAST	SOUTH	WEST			
101	CORRIDOR	1486 SF	LVT-1,2,3 WCPT-1	VB-1	P-1, P-2	P-1, P-2	P-1, P-2	P-1, P-2			SEE ELEVATIONS, FINISH NOTE 1, 2 SEE ELEVATIONS
104	WRESTLING	3738 SF	SAF-3	VB-1	P-1, P-3	P-1, P-2, P-3	P-1, P-2, P-3	P-1, P-3			
107	PRACTICE GYM	7952 SF	SAF-1, SAF-2	VB-1	P-1, P-2, P-3	P-1, P-2, P-3	P-1, P-2, P-3	P-1, P-2, P-3			
126	WOMENS LOCKERS	496 SF	ERF-1	ERF-COVE	P-1, CTP-B	P-1, CTP-A	P-1, CTP-B	P-1			
127	MENS LOCKERS	539 SF	ERF-1	ERF-COVE	P-1, CTP-C	P-1, CTP-C	P-1, CTP-B	P-1, CTP-A			CTP-B (CERAMIC TILE PATTERN)
128	STORAGE	898 SF	S-CONC	VB-1	P-1	P-1	P-1	P-1			
130	WOMENS	213 SF	PCT-1	SEE ELEV	CTP-E, P-5	P-1, 5	CTP-E, P-5	CTP-E, P-5			
131	MENS	212 SF	PCT-1	SEE ELEV	CTP-E, P-5	P-1, 5	CTP-E, P-5	CTP-E, P-5			

- FINISH NOTES:
- WALL PAINT PATTERN TO BE AS FOLLOWS STARTING AT THE FLOOR WORKING TOWARD THE CEILING. FIRST (5) COURSES TO BE P-1, 6TH COURSE TO BE P-2, 7TH COURSE TO THE CEILING TO BE P-1.
  - LVT FLOORING PATTERN TO BE AS SHOWN ON FINISH PLAN.

### FINISH MATERIAL SCHEDULE

MARK	MATERIAL	MANUFACTURER	STYLE	COLOR	SIZE/FINISH	REMARKS/LOCATION
ERF-1	EPOXY RESIN FLOORING	TNEMEC				REFER TO SPECIFICATIONS
GMT-1	GLASS MOSAIC TILE	SUSAN JABLON	ORDER # A112231	SKL# TX80		SAMPLE NEEDED FOR APPROVAL. INSTALL HORIZONTALLY WHERE SPECIFIED IN TILE PATTERNS
LVT-1	LUXURY VINYL TILE	MCHAWK	MATUTO	927-SONIC SILVER	12"X24"	INSTALL AS PER FINISH PLAN
LVT-2	LUXURY VINYL TILE	MCHAWK	MATUTO	915-FROST BITE	12"X24"	INSTALL AS PER FINISH PLAN
LVT-3	LUXURY VINYL TILE	MCHAWK	MATUTO	282-OUTRAGEOUS ORANGE	12"X24"	BRICK INSTALL AS SHOWN ON PLAN
P-1	PAINT	SHERWIN WILLIAMS		TBD-WHITE	SEE SPEC	SEE ROOM FINISH
P-2	PAINT	SHERWIN WILLIAMS		TBD-GREY	SEE SPEC	SEE ROOM FINISH
P-3	PAINT	SHERWIN WILLIAMS		TBD-ORANGE	SEE SPEC	SEE ROOM FINISH
P-4	PAINT	SHERWIN WILLIAMS		TBD-BLACK	SEE SPEC	SEE ROOM FINISH
P-5	PAINT	SHERWIN WILLIAMS		TBD-BATHROOM GREY	SEE SPEC	SEE ROOM FINISH
PCT-1	PORCELAIN TILE	SUNDERLAND BROTHERS	FLT-AVENTIS	VELVET AT2RA	12"X24"	BRICK INSTALL AS SHOWN ON PLAN
PCT-2	PORCELAIN TILE	DAL TILE	SEMIGLOSS	ARCTIC WHITE	4"X4"	AS SHOWN ON TILE PATTERNS AND ELEVATIONS
PCT-3	PORCELAIN TILE	DAL TILE	SEMIGLOSS	ICE GREY	4"X4"	AS SHOWN ON TILE PATTERNS AND ELEVATIONS
PCT-4	PORCELAIN TILE	SUNDERLAND BROTHERS	STONEPEAK/PARKLAND	SHANDENDAH	12"X24"	BRICK INSTALL AS SHOWN ON TILE PATTERNS AND ELEVATIONS
SAF-1	SYNTHETIC ATHLETIC FLOORING	TARKETT SPORTS		GOLDEN MAPLE	6.5MM	MAIN FLOOR COLOR
SAF-2	SYNTHETIC ATHLETIC FLOORING	TARKETT SPORTS		TBD FROM MANUF. STANDARDS	6.5MM	ACCENT FLOOR COLOR
SAF-3	SYNTHETIC ATHLETIC FLOORING	TARKETT SPORTS		GREY	6.5MM	WRESTLING ROOM COLOR
SCH-1	METAL EDGING/FINISHING STRIP	SCHLUTER SYSTEMS	QUADEC		BRUSHED STAINLESS	USE ON WALL TO FINISH TOP OF TILE RUN, AND ON ALL OUTSIDE CORNERS ON TILE WALLS, SEE ELEVATIONS
SCH-2	METAL EDGING/FINISHING STRIP	SCHLUTER SYSTEMS	RENO-U		BRUSHED STAINLESS	USE WHERE TILE AND LVT MEET TO AID IN HEIGHT TRANSITION
SCH-3	METAL EDGING/FINISHING STRIP	SCHLUTER SYSTEMS	DLEX-EHK		BRUSHED STAINLESS	USE FOR FLOORWALL TRANSITION IN RESTROOMS, SEE ELEVATIONS, TILE PATTERNS
SS-1	SOLID SURFACE	AVONITE		CEMENT K3842S		WOMENS LOCKER ROOM
TP-1	TOILET PARTITIONS	SCRANTON PRODUCTS		STAINLESS/HAMMERED		RESTROOM TOILET PARTITIONS
VB-2	VINYL WALL BASE	JOHNSONITE		48 GREY	4"	LOCKER ROOM SHOWER PARTITIONS, AND TOILET PARTITIONS
WCPT-1	WALK OFF CARPET TILE	MCHAWK	STEP IN STYLE II	955 COBALT	24" X 24"	MONOLITHIC INSTALLATION

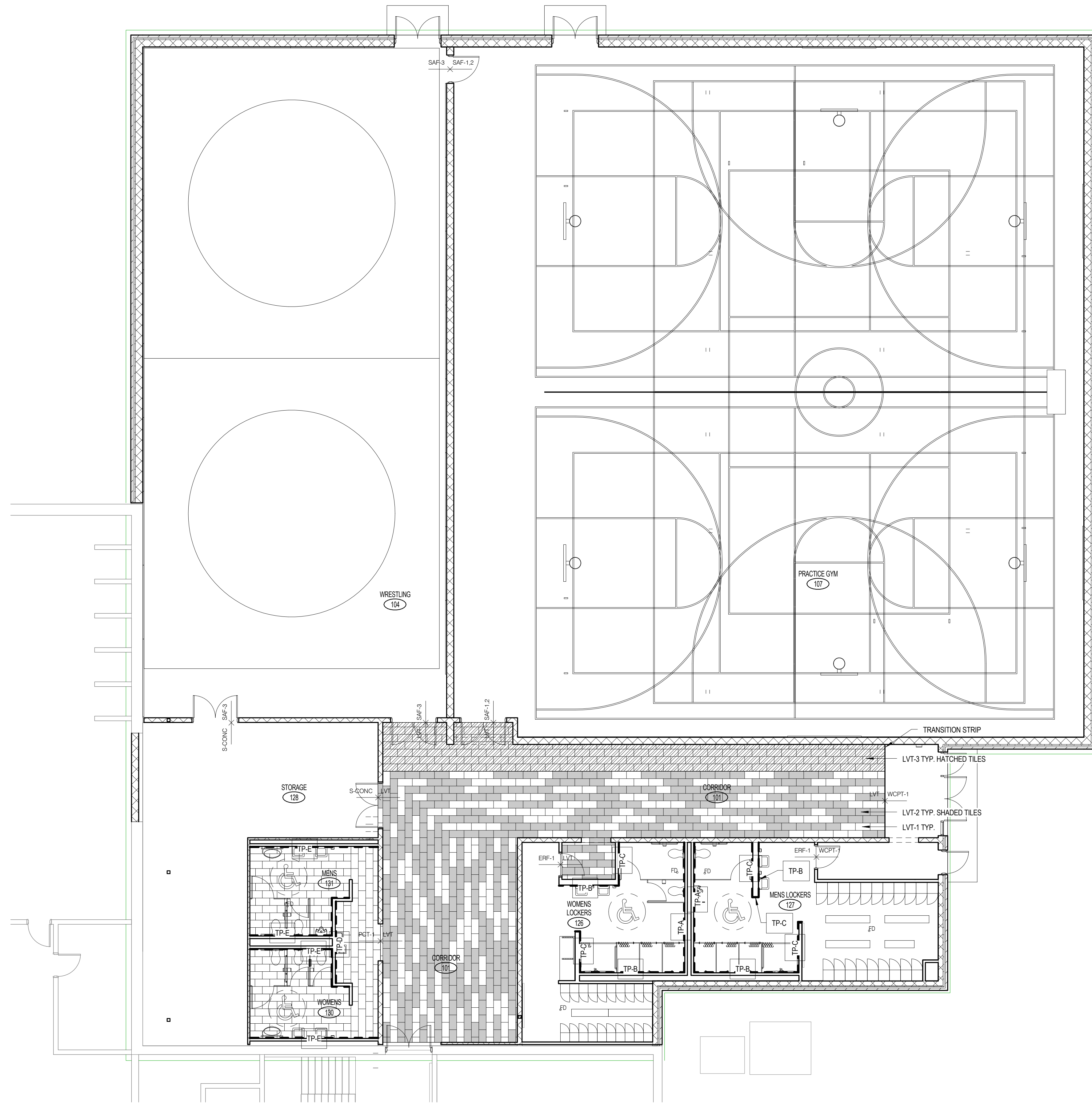

**1 GROUND LEVEL FINISH PLAN**  
1/8" = 1'-0"

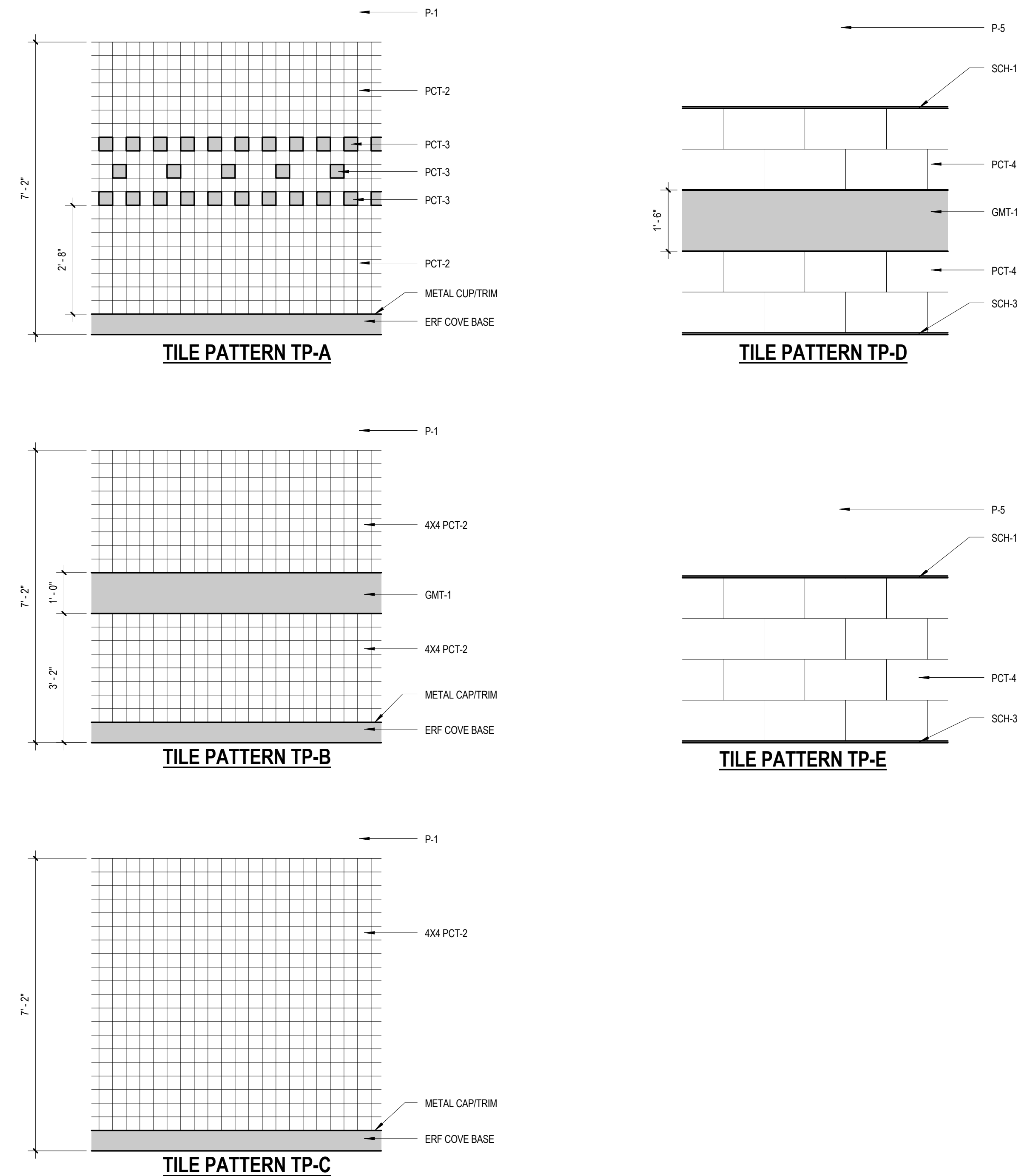

**2 TILE PATTERNS**  
1/2" = 1'-0"



Revision Schedule	No.	Date	Description

Project Title: **CHASE COUNTY SCHOOL - GYM ADDITION**  
520 EAST 9TH STREET  
IMPERIAL, NEBRASKA 68033  
CHASE COUNTY SCHOOLS

Sheet Title: **FINISH PLAN & SCHEDULES**  
Completion: 100% CONSTRUCTION DOCUMENTS  
Date Issued: MAY 16, 2016

Project: 203-003-15

Design	Drawing	Check
Designer	Author	Checker

Sheet No. **A-10.00**

## CHASE COUNTY SCHOOL GYM ADDITION

### Optional Cost Savings

#### Gym Flooring:

- Basis-of-Design: Tarkett Omnisports 6.5mm synthetic athletic flooring.  
<http://www.tarkettsportsindoor.com/en/products/omnisports>
- Switch to Dynamic Sports Construction; Dynaforce
  - <http://www.dynamicsportsconstruction.com/products/dynaforce/>
  - Savings of approximately \$6,000
  - Product has thinner wear layer
- Switch to hardwood Maple Sports Flooring
  - Still working on obtaining pricing. Estimates to be equal or higher than flooring included in design.

#### Wrestling Room Flooring:

- Basis-of-Design: Tarkett Omnisports 6.5mm synthetic athletic flooring.  
<http://www.tarkettsportsindoor.com/en/products/omnisports>
- Switch to no flooring. Sealed concrete floor.
  - Savings of approximately \$36,000

#### Skylights:

- Delete skylights from Gym and Wrestling room
  - Savings of approximately \$30,000

#### Roof System:

- Basis-of-Design: Tectum acoustical composite deck. Built in acoustical and insulation product.
- Switch to metal roof deck and separate insulation above deck. Will maintain same thermal properties but does not offer acoustical absorption.
  - Savings of approximately \$55,000

#### Exterior Finish:

- Basis-of-Design: Brick to 8'-0" and EIFS above to match existing.
- Switch to all EIFS Dryvit system along entire exterior of addition.
  - Deduct for Brick is \$56,000. Add for additional EIFS is \$34,000. Net deduct of \$22,000

#### Bleachers:

- Basis-of-Design: Telescoping stands with 400+ seats.
- Delete all seating, rough-in for power to add seating at a later time.
  - Savings of approximately \$34,000