

Board of Education
April 21, 2022 4:00 PM
Central Services Board Room

BOARD MEMBERS:

1. Call to Order - Mr. Robert Safdie
2. Moment of Silence and Pledge - Mr. Robert Safdie
3. Approval of Committee Minutes
4. CCHS Band Director Platform
5. Water Easement with City of Crossville
6. Other Discussion
7. Adjournment

**Building and Ground
Committee Meeting
April 5, 2022
Central Services Board Room**

The Building and Grounds Committee met on Tuesday, April 5, 2022, in the Central Services Board Room where Mr. Robert Safdie called the meeting to order at the approximate hour of 4:00 p.m. He welcomed everyone to the meeting and appreciated everyone for attending.

PRESENT:

Dr. Ina Maxwell, DOS	Ms. Shirley Parris, District 3
Mr. Jim Inman, District 1	Mary Kington, Maintenance Director
Mrs. Stephanie Barnes, CAO	Ms. Kacee Harris, CFO
Mr. Robert Safdie, Chairman, District 2	Heather Mullinax, Media

Absent: NONE

1. **Call to Order** – Mr. Robert Safdie
2. **Moment of Silence/Pledge of Allegiance** – Mr. Robert Safdie
3. **Approval of Minutes** – Mr. Robert Safdie

VOICE VOTE: Inman moved to approve.
Parris (seconder=yes)

MOTION: Carried unanimously

4. Stone Memorial High School Media Board

Safdie: We have 2 items on the agenda. 1 is the Stone Memorial High School Media Board and the other is the tennis courts. Mr. Inman you were very concerned about that and I think Mary is doing her research to give us information about that. So, let's handle the Stone Memorial High School Media Board. I am going to let Mary, Ms. Mary, will you turn to that page where the local product LLC Proforma is and explain to us what this is all about?

Kington: It's just a television, media center, that they are going to replace their existing score board, their football scoreboard with. They are planning on putting it right back up on the posts that are there so there's no architect involved in that and they are doing the installation with the company.

Safdie: How is the \$82,000 being paid for?

Kington: Football boosters.

Safdie: The football booster. We need to have a special thank you to the football boosters for that. Alright, are there any questions from our committee members?

Kington: On a side note, I talked to Tennessee Risk Management and we did go over and look at it, and they are ok with them doing that. You know how big the football scoreboard was and how heavy? Now we're going to a TV screen and it's going to be a lot lighter. So, he was ok with it-Tennessee Risk.

Safdie: Ok.

Inman: The only question that I have Mr. Chairman, is upkeep on it. Is that going to be our purview or is that going to be the booster club?

Kington: My understanding is it's the booster club.

Inman: Ok. Yeah, I don't have a problem with it.

Safdie: There's 1-year part warranty, 90 days labor warranty, it says all service and support will be out of Nashville. I imagine that they're going to need some training on that too?

Kington: Yes.

Safdie: And do we know who will be responsible, who will be the trainee?

Kington: That would come from Mr. Brown, the athletic director at Stone Memorial.

Safdie: Ok. Is there a motion to approve the media board for the high school?

Inman: Yeah, I move to approve.

Safdie: Is there a second?

Parris: Yes.

Safdie: Ms. Shirley seconds it. All in favor, is there a discussion?

Kington: Just one more thing, when I get to the insurance, that will also cover it Mr. Inman. If something happens to it, so it will be covered under our insurance. As soon as it's installed.

Inman: Once it's installed, it's our problem.

Safdie: Well, I think this is an interesting development, it's real progressive and I wish them the best of luck and the best uses. The motion is to approve this and submit it to the full board at the next board meeting. We have a second. All in favor say aye.

Inman/Parris: Aye.

Safdie: All opposed? Ayes have it. We'll send to the full board meeting. Next item, Mr. Inman you have been a champion for your concern for the high school tennis courts. This is a discussion and an exploration. Mary, I'd like for you to talk a little bit about it, incidentally this is where it's at, if you don't know. This is what she's given us. This is what we'll follow-the first page. Mary just start with that page and move on through it.

Kington: Ok, Stone Memorial-I was asked how many tennis courts they have, we actually have 6 at SMHS and right now they're able to play on 4. We have done some repair work on the first 4 that's there, 5 and 6 are almost to the point of unrepairable at this time.

Inman: Yeah, that's the ones where they had the real deep fissures.

Kington: Yes, and now they're even more.

Inman: Wider.

Kington: Yes. I just can't find anything that would...

Inman: I don't think there's anything you can put down there.

Kington: There's not. Ms. Smith seems to be very happy with the 4. She has tennis matches until the 27th and she's using all 4 of her courts. And then your second picture is CCHS. They have 8 courts. Number 7 & 8 are pretty good shape. 1 & 2 are the ones we are trying to work on. 3, 4, 5 and 6 are beyond repair.

Safdie: And what about 7&8 again?

Kington: They are ok. Number 8 has a crack right in the middle by the net. You could practice on them. I wouldn't think they would have a tournament on them. And number 7 is pretty good. We're repairing it a little bit so they can use it. Their last match is on Thursday the 7th at home.

Safdie: Do the board members have any questions for Mary?

Inman: We got any estimates back yet?

Kington: We do. CCHS comes in at \$525,000, SMHS comes in at \$400,000 for a total of \$925,000. Plus, we have to add \$20,000 for SMHS and \$25,000 for CCHS for new fence and gates. So, we're looking at, and if we have a 15% increase, we're over a million dollars.

Inman: I hate to say, but if you all will remember...

Safdie: You said I told you so.

Inman: There was a meeting that I told you it was going to be close to a million dollars.

Kington: Spot on by the time we get these installed properly. Just a quick note, SMHS has 7 girls on the tennis team with no boys and CCHS has 5 boys on the tennis team and 12 girls.

Safdie: Ok, I guess a couple of question. Mary, were they to go in on 5&6 at Stone Memorial and tear down from the ground and then rebuilt it?

Kington: They are tearing everything out. That's a total tear out and rebuild.

Safdie: Of 1, 2, 3, 4, 5, and 6?

Kington: All of them.

Safdie: They are just going to rake it all away.

Kington: Last year when we met over there and I contacted the architect, Kim talked with an engineer and said when that started on that end, it would just keep going and going because the ground is so unsettled there.

Inman: Oh boy, I think, I'm not an expert on construction but I've been around it enough that I know a little bit. I think the groundwork was probably not done exactly proper whenever it was first built. And to be honest with you, you wouldn't have been able to see it even if you'd been over there looking at it even when they were building it. You wouldn't have been able to know. It's just one of those things. It pops up 7, 8, 9 years after it's been built and there's nothing you can do about it but fix it.

Safdie: So, we're talking almost \$500,000 each just to plow down and tear up the tennis courts and re-asphalt them, putting a new foundation in?

Kington: Yes sir.

Safdie: I guess the question is, do we need all 6 at Stone Memorial High School and do we need all 8 at CCHS?

Inman: I would think yes. Tennis teams fluctuate year to year. You may have small group this year but next year may be bigger. As well as the fact that the PE classes use these as well. I've been there before. I've taught PE. You have 35 kids in a class, you need all the tennis courts you can get. In order to properly have class.

Kington: Does that mean you want to go to 8 at SMHS?

Inman: No.

Kington: No, leave it what it is?

Inman: I would like for it to be able to have 8 but I don't think we can afford it to be honest with you. Cause you're probably adding another 2-3 hundred thousand dollars if you add two more.

Kington: Ok, so leave them as they are.

Inman: Yeah. See, I don't understand why it was built with 6. We've got 8 at CCHS, why did they pick 6? I don't understand that. But I wasn't around during that time.

Safdie: Well, what do we want to do with it?

Inman: I think we need to send it to budget.

Kington: Well, I did put it in the maintenance budget. It's on the maintenance budget plan.

Safdie: Ok.

Inman: Now, Ms. Kacee, one thought is I know back several years ago when the budget tight, when the economy was really bad, the county commission and I think the school board did a capital outlay note on school buses or something for us and they were doing police cars or something. Is that a possibility for us to look at something like that?

Harris: That particular instance they sent it back and said find it in your budget for the school buses next year. Crab Orchard reno they took on-little bit different. I would suggest for now putting it on what I've dubbed the budget bulletin board and look at it in the scope of the whole budget as it becomes more developed and look and see what we can do. Maybe we can do 1 this year and plan for 1 next year, if it's too big of a project. Hopefully as we progress through the budget season, we'll also have some more final information about future funding from the state. I think all of those are options as well.

Safdie: Well, maintenance of effort won't be affected by a note, for instance?

Inman: No.

Harris: I think they could do it in a way where it was a county funded project. Not so much giving us the money to do it. At Crab Orchard I do not believe effected their maintenance effort. I think there's several ways to look at it. Personally, with the influx of money, the best plan would be to find a way to do it in house. I think that would be best most definitely.

Inman: I agree with you. I think that's the best plan. But that may not be possible. This is just me, but I would prefer if we are going to do them, we do them at the same time. I don't want a have and have not. And I don't want to get into a situation where we're waiting, of course I won't be around on here, but I don't want to wait 4 or 5 years because we couldn't afford to do it now. It's like waiting 60 years on an auditorium.

Parris: That's exactly what I was going to say.

Safdie: I think this is different because this is dangerous. Either close them down and say you can't play

on these tennis courts, or we get them fixed. That's all. All right is there a motion to refer this to the budget committee? Ms. Shirley, ok. Is there a second?

Inman: I'll second.

Safdie: Alright, is there any discussion, any further discussion? All in favor say aye.

Inman/Parris: Aye.

Safdie: All opposed say nay, the ayes have it. Mary, if this gets sent to the budget committee, they will have to be some real figures. We didn't specify which budget committee or which month but please do that. If they are going to make a recommendation, they are going to have to have exact numbers. So, I guess that means taking bids. What's the process for taking bids?

Inman: We won't take bids until the budget committee decides to do something.

Safdie: Ok.

Kington: The numbers that I presented you came from Mr. Chamberlain at Upland Design.

Safdie: Will the budget committee be satisfied with that?

Inman: Yeah.

Safdie: Ok. We have 2 other things up for discussion. The proposal for these aluminum 10 row stands. Mary, can you explain a little bit about that, and do we need to vote on that today? Or is this just a proposal.

Kington: I think it was just for your information today only, is that correct Jim?

Inman: Yes.

Kington: What I did was, I came back with, I didn't know how big we wanted to go or how small, this is 104 seats quote from Toadvine, which with installation, this does not include the concrete pad that they would have to set on. It came in at \$23,780.

Inman: I'll be honest with you I think 104 seats is probably not enough. If we're going to use that field for middle school football which is what I'd like it to be used for, 104 is not enough.

Kington: So, then maybe double it, triple it?

Safdie: Double it.

Inman: Well, at least double it. I think the size of the bleachers that's at Brown. I have no idea it seats.

Kington: And I tried to find that out and I couldn't.

Inman: Well, it's been there for so long.

Safdie: Do we have any idea what the pad is going to cost to set?

Kington: A 16x16 is right over a thousand dollars right now.

Inman: You're probably looking at anywhere from \$8-10 thousand dollars right now for a pad depending on the price at the time.

Kington: At least. And concrete is one of those many things that's jumped 3 prices so far this year.

Safdie: Jimmy, what would you like to do with this?

Inman: We just need to do some more research. I think if Mary will do some more research on some bigger bleachers.

Safdie: And does the principal at Martin agree that this is a necessity? And is agreeable?

Inman: Well, I think she's a little bit agreeable. She's not against it, let's put it that way. The last time I talked to her, she's not against it. I just feel like it's crazy for us to have a good facility like that's up there and not be using it. We need to get some traffic off of the high school football field. With the middle school playing on it and the high school playing and the Jr. Jets, it's way too much traffic on one football field.

Safdie: So, specifically what would you like at the next building and grounds committee or at a building and grounds committee in the future, we're going to have Mary present the cost of the specific cost so we can refer it to the budget committee?

Inman: Yeah.

Safdie: Mary, does that give you enough...

Kington: It does.

Parris: Mary, didn't Brown Elementary get new bleachers?

Kington: They were put in when they were set up.

Safdie: Yeah, when we built the school.

Parris: I know they had new ones when it was built but some bleachers was just brought over to a

neighbor's house that they got from Brown. They went in and were yard sales is all I know.

Kington: I hope not.

Parris: Well, I just know that they were there, I have pictures of them. I got pictures of them at that time, but nobody ever said anything about it, how did they get new bleachers? I know they got new bleachers when the school was built. This evidentially was them and they've got some since. That don't make sense.

Safdie: Ms. Ina, will you follow up on that? And try to find out what's going on?

Maxwell: Yes, I will.

Kington: Crab Orchard Elementary is the one that we took their bleachers when we demolished their field and put them at Martin.

Safdie: Put them at Martin, but we're talking about Brown.

Parris: I'm talking about Brown. That's what I understood at the time. Cause I asked the neighbor, where in the world did them school bleachers come from? She said out at Brown.

Kington: Were they huge?

Parris: They were used but they looked like they were in good shape.

Safdie: Were they wood?

Parris: No, they were those aluminum.

Kington: The last time I was at Brown, their bleachers were still there.

Inman: The only bleachers I've seen at Brown was the one big set of bleachers, I've never seen, the ones you're talking about are probably like the 3 rows, kind of like what's out at South. 3 or 4 rows.

Parris: I understood that just over time, I wondered why in the world they if were a newer school than South, why would they get new bleachers and South had never had any new ones?

Kington: I'm wondering that too.

Safdie: Well, let's let Ms. Ina work and figure out what's going on.

Parris: Those bleachers were sitting right next door to us in the neighbor's yard and she was using them to do her yard sale.

Safdie: Dr. Maxwell, do you need to go with Kacee to the meeting now?

Maxwell: If you will excuse me.

VOICE VOTE: Parris (mover-yes)
Inman (seconder-yes)
All Ayes

MOTION: Carried unanimously

5. New Business

Safdie: Does anyone else need to go now? We have one more point of discussion. This is under new business but it's just for discussion and it's not for any action at this point. Mary would you like to tell us about it?

Kington: The City of Crossville?

Safdie: No, the band.

Kington: Can I do the City of Crossville first?

Safdie: Yes.

Kington: Ok. I just wanted to update you on the cross walk at Martin. As I came through there today, I actually did see a utility truck there and they are scoping out to start setting the poles. So, they must have got their poles in and they are ready to set those but with this weather it will take 20 days for them to set. They are thinking 10-14 but snow this weekend, it's going to be 20 days. I just wanted to let you know they are moving forward. I don't know how we are going to help the community to know that situation.

That's a question that I had. It's not going to be a stop it's going to be a caution to let you know that it's possible somebody is crossing that road.

Safdie: Will the City put appropriate signage up?

Kington: Yes, they have approved for that. And it is really a City thing but being in front of our school that just sort of worries me. You know what I'm talking about.

Safdie: Finally, there was some concern about a bandstand. Just give us a little background on that. What's going on with this bandstand?

Kington: Mr. Johnson at CCHS, must be the band leader, director, requested to come to building and grounds for approval to get the platform, the director's platform for the marching band to have it redone. Actually, that's just a maintenance request. He's wanting some repair/replacement work.

Inman: That's over on their field?

Kington: Correct, it's beside the barn there.

Safdie: So, we'll see some work there being done but it will be handled through maintenance. What was the cost Mary, \$80 thousand?

Kington: I can't remember. Do you remember (to McCartney).

Safdie: It was close to \$60-80 thousand dollars.

Inman: What? Are we making it out of gold?

Safdie: Well, that's why Mary said that we'll do this through maintenance and go through the maintenance process. It's just a repair. There are many reasons why, do you have the price?

Kington: We're still scanning. I went back when Ms. Diane shared it with me and me and Ina agree-he should have taken this up with Mr. Hall first. And see what the decision was and do a work order for maintenance to come out and review what it is.

Inman: What does he want, to just completely start over?

Safdie: Yes.

Kington: Yes, and I can share these pictures with you.

Inman: No, I don't need them.

Kington: I admit there is some problems there, but this is the first time I had seen those.

Inman: Well, I'm sure, it's been there for what, 20 years? 25 years?

Safdie: At least. Since Stone Memorial High School was built.

Kington: At least.

Inman: No, it's been long before that. I think Steve Tinnel had that built. It's been there for a long time.

Safdie: I don't remember.

Inman: It wasn't there when I graduated in '74, let's put it that way.

Safdie: There is an effort on the band boosters, whatever the cost is after its bid out, they said that they would pay for it.

Inman: They want to demolish what's there, and start over?

Kington: Yes, and it's pretty elaborate. He wants it to be 8 feet tall and was it 15 feet wide? I'll review this with maintenance.

Safdie: Thank you for the work. Is there anything else that we need to discuss? Is there a motion...

6. Adjournment

Inman: I move to adjourn.

Parris: I second.

Safdie: All in favor, aye, aye. No opposes. Meeting is adjourned.

VOICE VOTE: Inman (mover-yes)

Parris (seconder-yes)

All Ayes

MOTION: Carried unanimously.

The meeting was adjourned at approximately 4:30 pm.

Dr. Ina Maxwell
Director of Schools

Mr. Robert Safdie
Chairman of the Building & Grounds Committee

Diane McCartney
Executive Assistant for the Director of Schools and BOE

March 31, 2022

Bruce Johnson
Band Director - Cumberland County High School
660 Stanley Street,
Crossville, TN, 38555
931-484-6709

Dear Building and Grounds Committee,

My name is Bruce Johnson, and I am the band director at Cumberland County High School. The reason for this letter is that I would like to ask permission to rebuild the band's observation deck on our practice field. The existing structure is falling apart, and there are a great many issues with the existing structure when it comes to meeting building code. I feel it would be a better use of time and resources to tear the existing structure down and rebuild it rather than to try and fix what is there. The CCHS Band Boosters will pay for all the materials necessary to tear down the existing structure and to build the new structure in its place.

I have included a picture of the existing structure, labeled as **Image 1**. I would like to draw your attention to the joist header on the front of the structure. The joist header is made out of a 2x10 board, which is a common piece of lumber to use for a joist header. However, the joist header was simply nailed to the outside of the 6x6 posts rather than the 6x6 post being notched out to allow the joist header to sit inside the 6x6 post. The installation of the joist header places all of the weight of the platform on the nails holding the joist header to the 6x6, rather than allowing the weight of the platform to be supported by the 6x6 post.

Next, I would like to draw your attention to the concrete at the base of the 6x6 posts, shown below in **Image 2A** and **Image 2B**. The concrete is cracking and breaking away. When taking a closer look at them, it seems as though the concrete was simply poured on the surface of the ground around the 6x6 post, rather than being poured into the hole dug in the ground for the 6x6 post to harden around the 6x6 post in the ground. In **Image 2A** you can also see how the cross braces were attached to the 6x6 posts in an attempt to provide added structural support so that the structure would not twist. The cross brace's structural integrity is solely based on how strong the nails that hold the board to the 6x6 are.

I would like to now draw your attention to the stairs on the existing structure, shown below in **Image 3**. The stairs on the existing structure have several issues with them. The first way that the existing stairs do not meet code is the rise/run of the individual steps. The standard rise/run from the IRC for stairs is 7 inches of rise and 10-11 inches of tread for each step. The current steps are 8 inches of rise and only 8 inches of tread. These stairs are extremely awkward when coming down from the platform, as they are very shallow. The second issue with the current stairs is that the stairs run off onto a row of cinder blocks that are simply laid on the ground. The stairs are becoming more and more unstable as the cinder blocks continue to settle, the ground under the cinder blocks changes, and as the cinder blocks crack.

Finally, I would like to draw your attention to the guardrail around the perimeter of the platform, shown in **Image 4**. Building code states that any platform that is more than 30 inches off the ground must have a guard rail. The 2x4 boards that were put in place to serve as the guardrail were attached with nails instead of screws. Because of this, I almost fell off the platform when leaning against the guardrail during an after-school rehearsal this year. This was due to the nails backing out of the 6x6 post. Also stated in the guardrail code is the need for balusters on the guard rail. These balusters must be no more than 4 inches apart, and the space between the bottom of the balusters and the top of the floor of the platform cannot exceed 4 inches either (this code also applies to the handrail for the stairs). As you can see in the image, there are no balusters around the entire platform, and there are no balusters on the handrail for the stairs either.

With all this in mind, I believe that it would be in the best interest of everyone that uses this platform (myself, other band staff/instructors, and select band students) that we tear out what is currently there and rebuild the platform. As stated earlier in this proposal, the CCHS band boosters will provide all materials and labor necessary for demolition of the existing structure and for the building of the proposed structure. I have included sketches I have drawn of the platform I would like to build in its place. When making these drawings, I consulted a former residential and commercial contractor who now works for Christman Construction in Knoxville to ensure that all of the elements of this build would meet code and be extremely structurally sound. I will be happy to attend your next meeting to answer any questions you may have concerning the new structure. Thank you for your time and consideration, and I look forward to seeing you on April 5.

Sincerely,

Bruce Johnson

Image 1



Image 2A



Image 2B



Image 3



Image 4



Sketches of New Structure

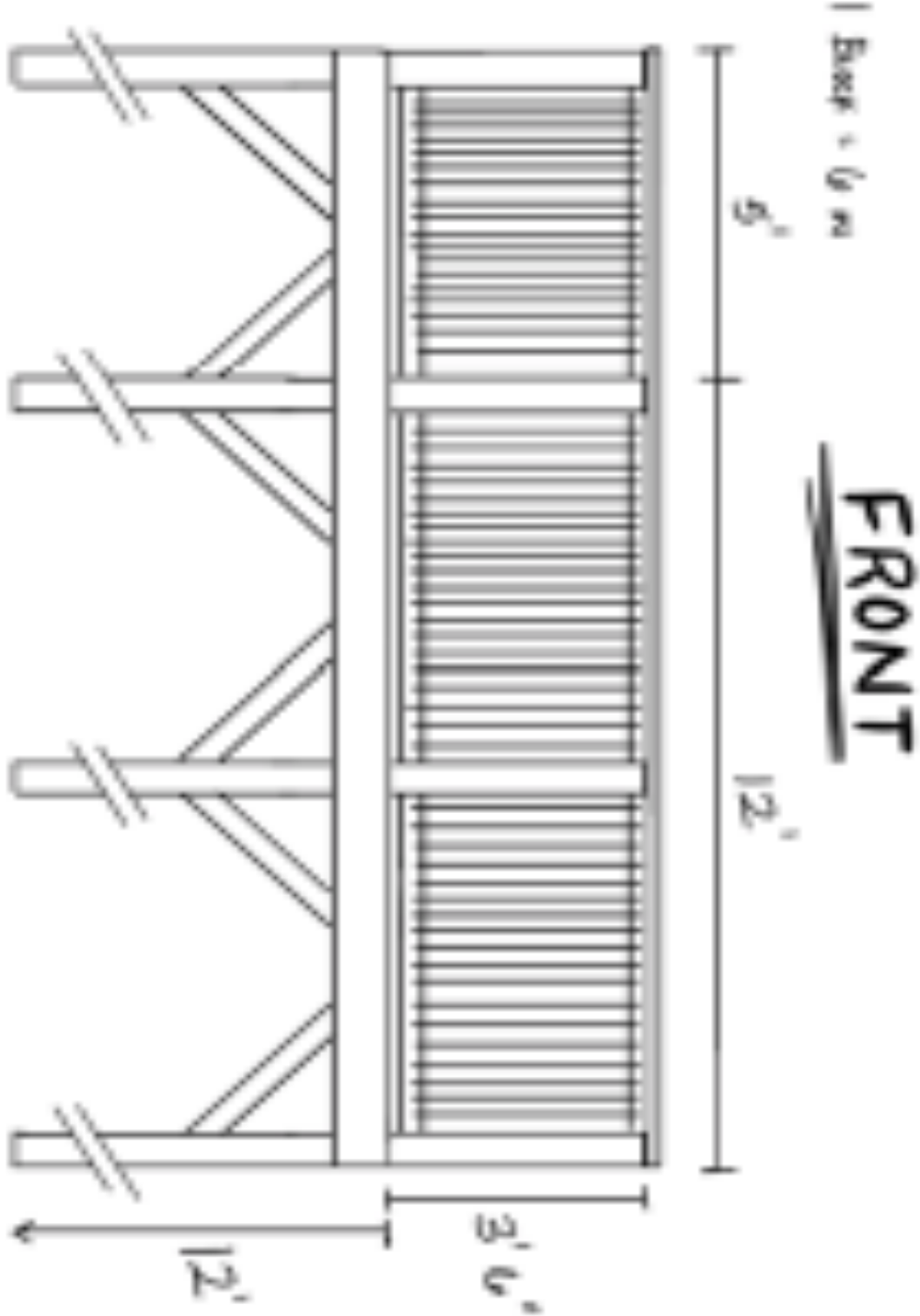

LEFT

1 Board = 6" x 24"

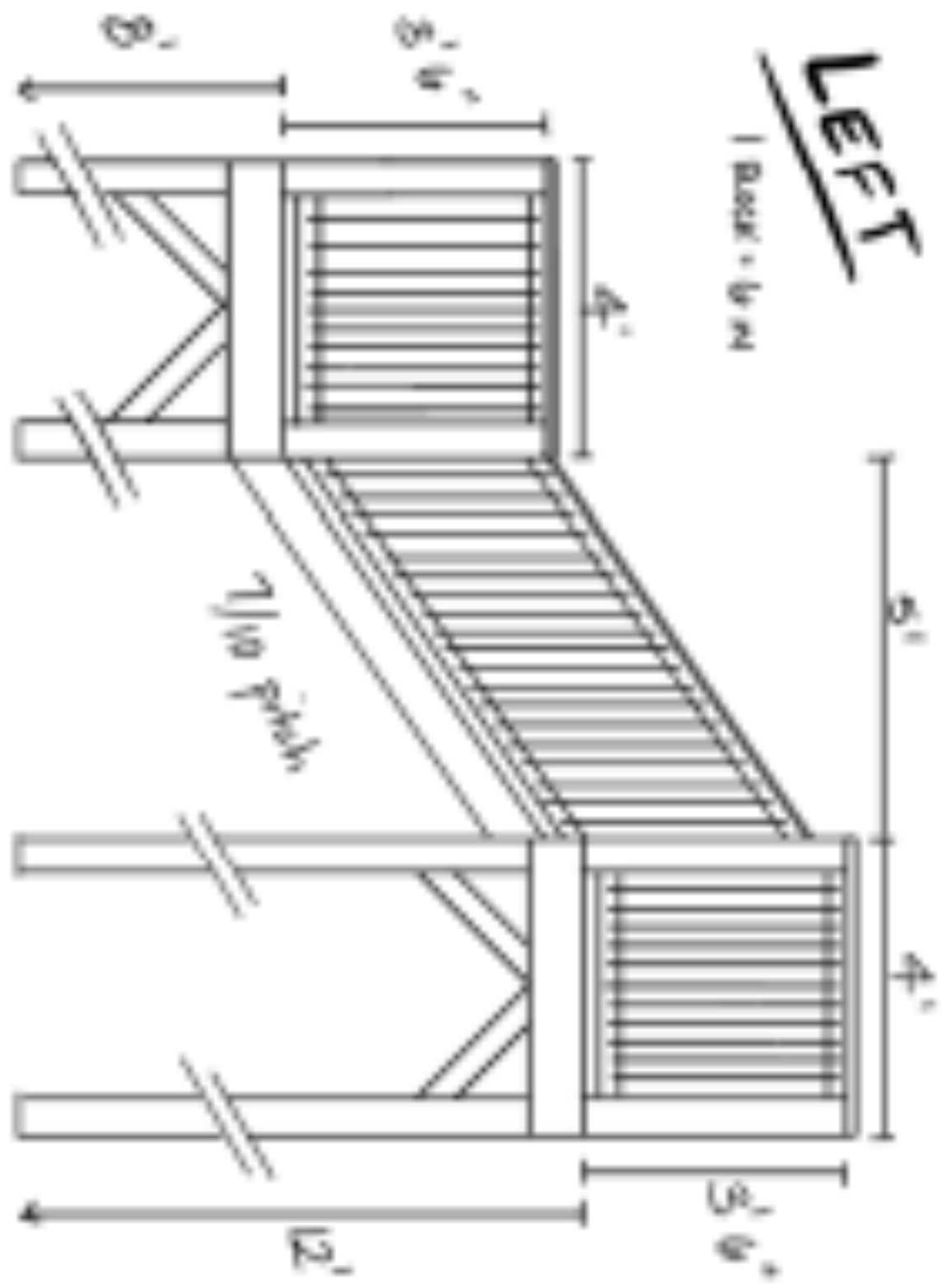

BACK

1 Blouse + 5 m

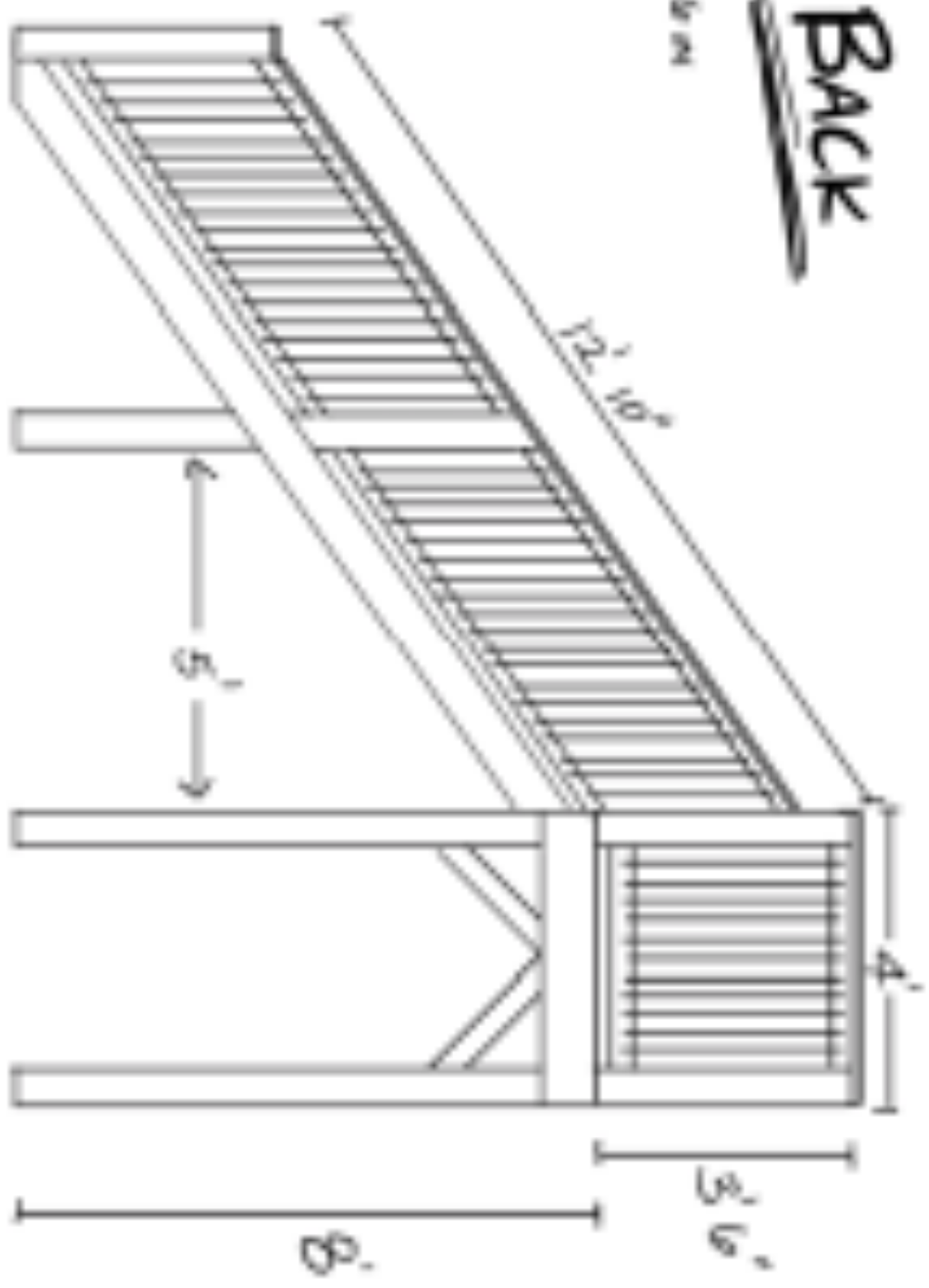

Prepared by William T. Ridley
Attorney at Law
157 Lantana Road
Crossville, Tennessee 38555

**It is the responsibility of the Grantee of this instrument
to immediately record it. Failure to record this
instrument could adversely affect the validity of your title.**

EASEMENT

For and in consideration of the sum of Ten Dollars (\$10.00), cash in hand paid, and other good and valuable consideration not herein mentioned, receipt of all of which is hereby acknowledged, **CUMBERLAND COUNTY BOARD OF EDUCATION**, have this day bargained and sold and by these presents do hereby bargain, sell, transfer and convey its interest unto the **CITY OF CROSSVILLE, TENNESSEE**, a municipal corporation, its representatives, successors, and assigns an easement herein described below. Said easement is described as follows:

In the First Civil District of Cumberland County, Tennessee, bounded and described as follows:

Map 139 – Parcel 014.00

Parcel No. 1: 20 ft wide Permanent Water Line Easement

Beginning at point in the East Right of Way line of Highway 127 South (SR# 28, ROW varies) and the West line of the Cumberland County Board of Education property as recorded at Book 83 Page 182, which this Permanent Water Line Easement is a part, being the Southwest corner of this easement, said point being North 37 degrees 44 minutes 46 seconds East, a distance of 80.08 feet from being the Southwest corner of the Cumberland County Board of Education property; thence in a Northeastwardly direction, along the East Right of Way line of Highway 127 South, also being the West line of the Cumberland Board of Education property and this easement, the following two (2) courses; North 37 degrees 44 minutes 46 seconds East, a distance of 72.28 feet to an angle point; thence North 35 degrees 38 minutes 51 seconds East, a distance of 19.94 feet to the Northwest corner of this easement; thence in a Southeastwardly direction, along a North line of this easement, South 56 degrees 26 minutes 12 seconds East, a distance of 37.00 feet to an interior corner of this easement; thence in a Northeastwardly direction, along a West line of this easement, North 33 degrees 33 minutes 48 seconds East, a distance of 32.08 feet to an exterior corner of this

easement; thence in a Southeastwardly direction, along a North line of this easement, South 56 degrees 26 minutes 12 seconds East, a distance of 20.00 feet to an exterior corner of this easement; thence in Southwestwardly direction, along an East line of this easement, South 33 degrees 33 minutes 48 seconds West, a distance of 32.08 feet to an interior corner of this easement; thence in a Southeastwardly direction, along a North line of this easement, South 56 degrees 26 minutes 12 seconds East, a distance of 28.98 feet to the Northeast corner of this easement; thence in a Southwestwardly direction, along an East line of this easement, South 33 degrees 33 minutes 48 seconds West, a distance of 20.00 feet to an exterior corner of this easement; thence in a Northwestwardly direction, along a South line of this easement, North 56 degrees 26 minutes 12 seconds West, a distance of 66.66 feet to an interior corner of this easement; thence in a Southwestwardly direction, along an East line of this easement, South 37 degrees 44 minutes 46 Seconds West, a distance of 73.67 feet to the Southeast corner of this easement; thence in a Northwestwardly direction, along a South line of this easement, North 52 degrees 15 minutes 14 seconds West, a distance of 20.00 feet to the point of beginning, and crosses the grantor's property in the approximate location as described and as shown on Exhibit "A" attached hereto.

Said easement crosses the property conveyed to the grantor herein by virtue of a deed of record in Book 83, Page 182, Register's Office, Cumberland County, Tennessee.

Parcel No. 2: Temporary Construction Easement

Easement of variable width lying adjacent to the above-described Permanent Water Line Easement, and crosses the grantor's property in the approximate location as described and as shown on Exhibit "A" attached hereto.

Said easement crosses the property conveyed to the grantor herein by virtue of a deed of record in Book 83, Page 182, Register's Office, Cumberland County, Tennessee.

TO HAVE AND TO HOLD the above-described property to the grantee, herein named, its successors, representatives, and assigns, forever.

Grantor covenants with the Grantee herein named, that Grantor is lawfully seized and possessed of said real estate; have a good and lawful right to convey same, that it is free and unencumbered, except as above set out, and that Grantor will forever warrant and defend the title thereto against the lawful claims of any and all persons whomsoever, and Grantor binds its heirs, successors, and assigns by the above covenants.

Preparer of this instrument makes no representation to the validity of the title contained herein.

This instrument was prepared from information furnished by the parties herein for which the preparer assumes no responsibility.

Executed this ____ day of _____, 2022.

CUMBERLAND COUNTY BOARD OF EDUCATION

By: _____

Its: _____

STATE OF TENNESSEE
COUNTY OF CUMBERLAND

Before me, the undersigned authority, a Notary Public, in and for said State and County, personally appeared _____, with whom I am personally acquainted (or proved to me on the basis of satisfactory evidence) and who upon oath, acknowledged himself/herself to be the _____ of **Cumberland County Board of Education**, and that he/she as such _____, being authorized so to do, executed the foregoing instrument for the purposes therein contained, by signing the name of the **Cumberland County Board of Education** by himself/herself as _____.

Witness my hand and official seal of office on this the ____ day of _____, 2022.

Notary Public

My commission expires: _____

Tax Map 139
Parcel 014.00

Property Owner: Cumberland County Board of Education

Said Permanent Water Line Easement is described as follows:

In the First Civil District of Cumberland County, Tennessee, described as follows:

20 ft wide Permanent Water Line Easement

Beginning at point in the East Right of Way line of Highway 127 South (SR# 28, ROW varies) and the West line of the Cumberland County Board of Education property as recorded at Book 83 Page 182, which this Permanent Water Line Easement is a part, being the Southwest corner of this easement, said point being North 37 degrees 44 minutes 46 seconds East, a distance of 80.08 feet from being the Southwest corner of the Cumberland County Board of Education property; thence in a Northeastwardly direction, along the East Right of Way line of Highway 127 South, also being the West line of the Cumberland Board of Education property and this easement, the following two (2) courses; North 37 degrees 44 minutes 46 seconds East, a distance of 72.28 feet to an angle point; thence North 35 degrees 38 minutes 51 seconds East, a distance of 19.94 feet to the Northwest corner of this easement; thence in a Southeastwardly direction, along a North line of this easement, South 56 degrees 26 minutes 12 seconds East, a distance of 37.00 feet to an interior corner of this easement; thence in a Northeastwardly direction, along a West line of this easement, North 33 degrees 33 minutes 48 seconds East, a distance of 32.08 feet to an exterior corner of this easement; thence in a Southeastwardly direction, along a North line of this easement, South 56 degrees 26 minutes 12 seconds East, a distance of 20.00 feet to an exterior corner of this easement; thence in Southwestwardly direction, along an East line of this easement, South 33 degrees 33 minutes 48 seconds West, a distance of 32.08 feet to an interior corner of this easement; thence in a Southeastwardly direction, along a North line of this easement, South 56 degrees 26 minutes 12 seconds East, a distance of 28.98 feet to the Northeast corner of this easement; thence in a Southwestwardly direction, along an East line of this easement, South 33 degrees 33 minutes 48 seconds West, a distance of 20.00 feet to an exterior corner of this easement; thence in a Northwestwardly direction, along a South line of this easement, North 56 degrees 26 minutes 12 seconds West, a distance of 66.66 feet to an interior corner of this easement; thence in a Southwestwardly direction, along an East line of this easement, South 37 degrees 44 minutes 46 Seconds West, a distance of 73.67 feet to the Southeast corner of this easement; thence in a Northwestwardly direction, along a South line of this easement, North 52 degrees 15 minutes 14 seconds West, a distance

of 20.00 feet to the point of beginning, and crosses the grantor's property in the approximate location as described and as shown on Exhibit "A" attached hereto.

Said easement crosses the property conveyed to the grantor herein by virtue of a deed of record in Book 83, Page 182, Register's Office, Cumberland County, Tennessee.

Temporary Construction Easement

Easement of variable width lying adjacent to the above-described Permanent Water Line Easement, and crosses the grantor's property in the approximate location as described and as shown on Exhibit "A" attached hereto.

Said easement crosses the property conveyed to the grantor herein by virtue of a deed of record in Book 83, Page 182, Register's Office, Cumberland County, Tennessee.

LINE	BEARING	DISTANCE
L1	N 37°44'46" E	72.28'
L2	N 35°38'51" E	19.94'
L3	S 56°26'12" E	37.00'
L4	N 33°33'48" E	32.08'
L5	S 56°26'12" E	20.00'
L6	S 33°33'48" W	32.08'
L7	S 56°26'12" E	28.98'
L8	S 33°33'48" W	20.00'
L9	N 56°26'12" W	66.66'
L10	S 37°44'46" W	73.67'
L11	N 52°15'14" W	20.00'

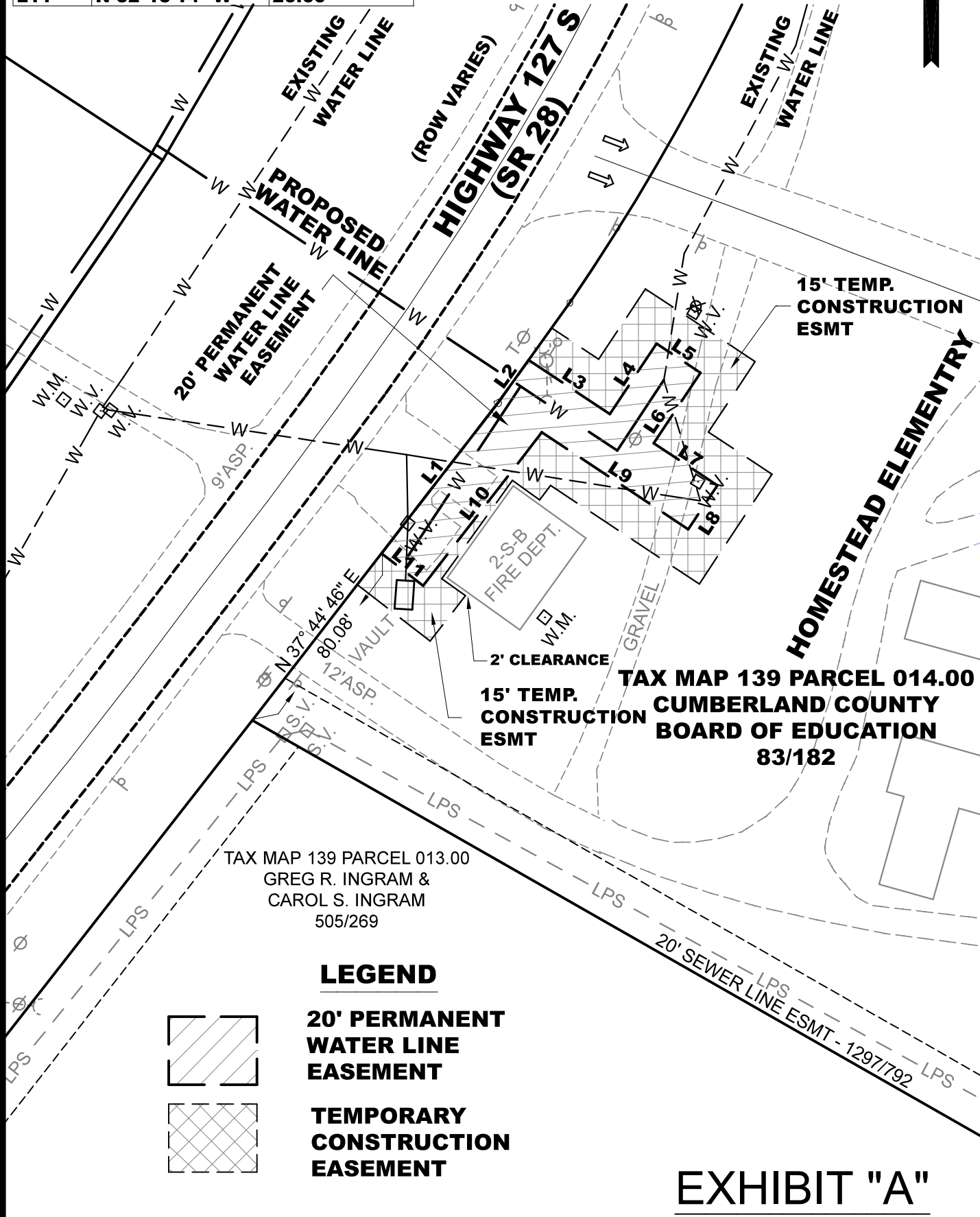

TAX MAP 139 PARCEL 013.00
 GREG R. INGRAM &
 CAROL S. INGRAM
 505/269

TAX MAP 139 PARCEL 014.00
CUMBERLAND COUNTY
BOARD OF EDUCATION
83/182

LEGEND

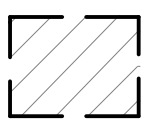

**20' PERMANENT
 WATER LINE
 EASEMENT**

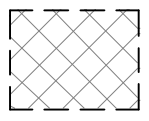

**TEMPORARY
 CONSTRUCTION
 EASEMENT**

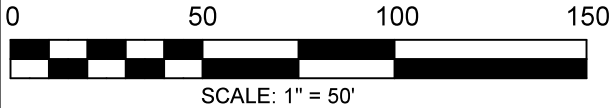

NOTE:
 1. The survey was done under the authority of TCA 62-18-126;
 2. The survey is not a general property survey as defined under Rule 0820.03-7.

EXHIBIT "A"

DATE: 03/18/2022

WATER LINE EASEMENT
 CUMBERLAND COUNTY BOARD OF EDUCATION
 HOMESTEAD ELEMENTARY SCHOOL
 TAX MAP 139 PARCEL 014.00

**CITY OF CROSSVILLE
 ENGINEERING DEPARTMENT**
 392 N MAIN ST
 CROSSVILLE, TN 38555
 PHONE: (931) 484-5113
 FAX: (931) 484-7713